

Document Title

512Kx36-bit, 1Mx18-bit QDR™ SRAM

Revision History

<u>Rev. No.</u>	<u>History</u>	<u>Draft Date</u>	<u>Remark</u>
0.0	1. Initial document.	Jan. 27, 2004	Advance
1.0	1. Final spec release	Mar. 18, 2004	Final

The attached data sheets are prepared and approved by SAMSUNG Electronics. SAMSUNG Electronics CO., LTD. reserve the right to change the specifications. SAMSUNG Electronics will evaluate and reply to your requests and questions on the parameters of this device. If you have any questions, please contact the SAMSUNG branch office near your office, call or contact Headquarters.

512Kx36-bit, 1Mx18-bit QDR™ SRAM

FEATURES

- 1.8V/2.5V +0.1V/-0.1V Power Supply.
- I/O Supply Voltage 1.5V +0.1V/-0.1V for 1.5V I/O, 1.8V+0.1V/-0.1V for 1.8V I/O.
- Separate independent read and write data ports with concurrent read and write operation.
- HSTL I/O.
- Full data coherency, providing most current data .
- Synchronous pipeline read with self timed late write.
- Registered address, control and data input/output.
- DDR(Double Data Rate) Interface on read and write ports.
- Fixed 4-bit burst for both read and write operation.
- Clock-stop supports to reduce current.
- Two input clocks(K and \bar{K}) for accurate DDR timing at clock rising edges only.
- Two input clocks for output data(C and \bar{C}) to minimize clock-skew and flight-time mismatches.
- Single address bus.
- Byte writable function.
- Sepatate read/write control pin(\bar{R} and \bar{W})
- Simple depth expansion with no data contention.
- Programmable output impedance.
- JTAG 1149.1 compatible test access port.
- 165FBGA(11x15 ball array FBGA) with body size of 13x15mm

Organization	Part Number	Cycle Time	Access Time	Unit
X36	K7Q163664B-FC16	6.0	2.5	ns
X18	K7Q161864B-FC16	6.0	2.5	ns

FUNCTIONAL BLOCK DIAGRAM

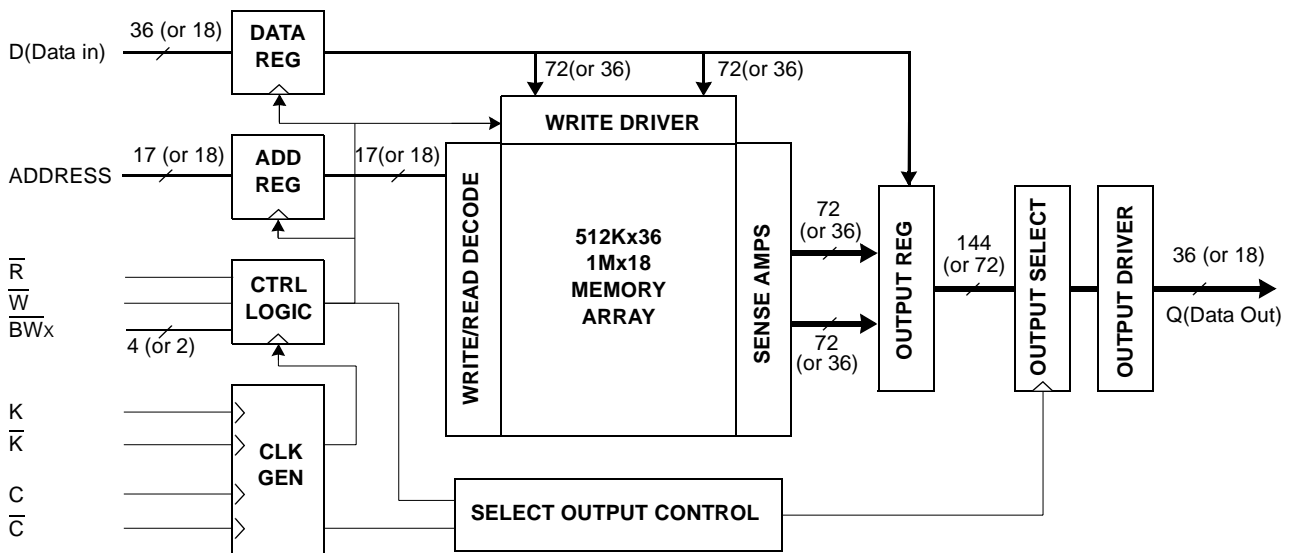

Notes: 1. Numbers in () are for x18 device.

QDR SRAM and Quad Data Rate comprise a new family of products developed by Cypress, Hitachi, IDT, Micron, NEC and Samsung technology.

PIN CONFIGURATIONS(TOP VIEW) K7Q161864B(1Mx18)

	1	2	3	4	5	6	7	8	9	10	11
A	NC	Vss	NC	\overline{W}	\overline{BW}_1	\overline{K}	NC	\overline{R}	SA	Vss	NC
B	NC	Q9	D9	SA	NC	K	\overline{BW}_0	SA	NC	NC	Q8
C	NC	NC	D10	Vss	SA	NC	SA	Vss	NC	Q7	D8
D	NC	D11	Q10	Vss	Vss	Vss	Vss	Vss	NC	NC	D7
E	NC	NC	Q11	VDDQ	Vss	Vss	Vss	VDDQ	NC	D6	Q6
F	NC	Q12	D12	VDDQ	VDD	Vss	VDD	VDDQ	NC	NC	Q5
G	NC	D13	Q13	VDDQ	VDD	Vss	VDD	VDDQ	NC	NC	D5
H	NC	VREF	VDDQ	VDDQ	VDD	Vss	VDD	VDDQ	VDDQ	VREF	ZQ
J	NC	NC	D14	VDDQ	VDD	Vss	VDD	VDDQ	NC	Q4	D4
K	NC	NC	Q14	VDDQ	VDD	Vss	VDD	VDDQ	NC	D3	Q3
L	NC	Q15	D15	VDDQ	Vss	Vss	Vss	VDDQ	NC	NC	Q2
M	NC	NC	D16	Vss	Vss	Vss	Vss	Vss	NC	Q1	D2
N	NC	D17	Q16	Vss	SA	SA	SA	Vss	NC	NC	D1
P	NC	NC	Q17	SA	SA	C	SA	SA	NC	D0	Q0
R	TDO	TCK	SA	SA	SA	\overline{C}	SA	SA	SA	TMS	TDI

Notes: 1. \overline{BW}_0 controls write to D0:D8 and \overline{BW}_1 controls write to D9:D17.

PIN NAME

SYMBOL	PIN NUMBERS	DESCRIPTION	NOTES
K, \overline{K}	6B, 6A	Input Clock	
C, \overline{C}	6P, 6R	Input Clocks for Output data	1
SA	9A,4B,8B,5C,7C,5N-7N,4P,5P,7P,8P,3R-5R,7R-9R	Address Inputs	
D ₀₋₁₇	10P,11N,11M,10K,11J,11G,10E,11D,11C,3B,3C,2D,3F,2G,3J,3L,3M,2N	Data Inputs	
Q ₀₋₁₇	11P,10M,11L,11K,10J,11F,11E,10C,11B,2B,3D,3E,2F,3G,3K,2L,3N,3P	Data Outputs	
\overline{W}	4A	Write Control	
\overline{R}	8A	Read Control	
$\overline{BW}_0, \overline{BW}_1$	7B, 5A	Byte Write Control	
VREF	2H,10H	Input Reference Voltage	
ZQ	11H	Output Driver Impedance Control	2
VDD	5F,7F,5G,7G,5H,7H,5J,7J,5K,7K	Power Supply (2.5V)	
VDDQ	4E,8E,4F,8F,4G,8G,3H,4H,8H,9H,4J,8J,4K,8K,4L,8L	Output Power Supply (1.5V or 1.8V)	
Vss	2A,10A,4C,8C,4D-8D,5E-7E,6F,6G,6H,6J,6K,5L-7L,4M-8M,4N,8N	Ground	
TMS	10R	JTAG Test Mode Select	
TDI	11R	JTAG Test Data Input	
TCK	2R	JTAG Test Clock	
TDO	1R	JTAG Test Data Output	
NC	3A,7A,1B,5B,9B,10B,1C,2C,6C,9C,1D,9D,10D,1E,2E,9E,1F,9F,10F,1G,9G,10G,1H,1J,2J,9J,1K,2K,9K,1L,9L,10L,1M,2M,9M,1N,9N,10N,1P,2P,9P	No Connect	3

Notes: 1. C, \overline{C} , K or \overline{K} cannot be set to VREF voltage.

2. When ZQ pin is directly connected to VDD output impedance is set to minimum value and it cannot be connected to ground or left unconnected.

3. Not connected to chip pad internally.

K7Q163664B
K7Q161864B

512Kx36 & 1Mx18 QDR™ b4 SRAM

PIN CONFIGURATIONS(TOP VIEW) K7Q163664B(512Kx36)

	1	2	3	4	5	6	7	8	9	10	11
A	NC	Vss	NC	\overline{W}	\overline{BW}_2	\overline{K}	\overline{BW}_1	\overline{R}	NC	Vss	NC
B	Q27	Q18	D18	SA	\overline{BW}_3	K	\overline{BW}_0	SA	D17	Q17	Q8
C	D27	Q28	D19	Vss	SA	NC	SA	Vss	D16	Q7	D8
D	D28	D20	Q19	Vss	Vss	Vss	Vss	Vss	Q16	D15	D7
E	Q29	D29	Q20	VDDQ	Vss	Vss	Vss	VDDQ	Q15	D6	Q6
F	Q30	Q21	D21	VDDQ	VDD	Vss	VDD	VDDQ	D14	Q14	Q5
G	D30	D22	Q22	VDDQ	VDD	Vss	VDD	VDDQ	Q13	D13	D5
H	NC	VREF	VDDQ	VDDQ	VDD	Vss	VDD	VDDQ	VDDQ	VREF	ZQ
J	D31	Q31	D23	VDDQ	VDD	Vss	VDD	VDDQ	D12	Q4	D4
K	Q32	D32	Q23	VDDQ	VDD	Vss	VDD	VDDQ	Q12	D3	Q3
L	Q33	Q24	D24	VDDQ	Vss	Vss	Vss	VDDQ	D11	Q11	Q2
M	D33	Q34	D25	Vss	Vss	Vss	Vss	Vss	D10	Q1	D2
N	D34	D26	Q25	Vss	SA	SA	SA	Vss	Q10	D9	D1
P	Q35	D35	Q26	SA	SA	C	SA	SA	Q9	D0	Q0
R	TDO	TCK	SA	SA	SA	\overline{C}	SA	SA	SA	TMS	TDI

Notes: 1. \overline{BW}_0 controls write to D0:D8, \overline{BW}_1 controls write to D9:D17, \overline{BW}_2 controls write to D18:D26 and \overline{BW}_3 controls write to D27:D35.

PIN NAME

SYMBOL	PIN NUMBERS	DESCRIPTION	NOTES
K, \overline{K}	6B, 6A	Input Clock	
C, \overline{C}	6P, 6R	Input Clocks for Output data	1
SA	4B,8B,5C,7C,5N-7N,4P,5P,7P,8P,3R-5R,7R-9R	Address Inputs	
D0-35	10P,11N,11M,10K,11J,11G,10E,11D,11C,10N,9M,9L 9J,10G,9F,10D,9C,9B,3B,3C,2D,3F,2G,3J,3L,3M,2N 1C,1D,2E,1G,1J,2K,1M,1N,2P	Data Inputs	
Q0-35	11P,10M,11L,11K,10J,11F,11E,10C,11B,9P,9N,10L 9K,9G,10F,9E,9D,10B,2B,3D,3E,2F,3G,3K,2L,3N 3P,1B,2C,1E,1F,2J,1K,1L,2M,1P	Data Outputs	
\overline{W}	4A	Write Control Pin	
\overline{R}	8A	Read Control Pin	
$\overline{BW}_0, \overline{BW}_1, \overline{BW}_2, \overline{BW}_3$	7B,7A,5A,5B	Byte Write Control Pin	
VREF	2H,10H	Input Reference Voltage	
ZQ	11H	Output Driver Impedance Control	2
VDD	5F,7F,5G,7G,5H,7H,5J,7J,5K,7K	Power Supply (2.5V)	
VDDQ	4E,8E,4F,8F,4G,8G,3H,4H,8H,9H,4J,8J,4K,8K,4L,8L	Output Power Supply(1.5V or 1.8V)	
Vss	2A,10A,4C,8C,4D-8D,5E-7E, 6F,6G,6H,6J,6K,5L-7L,	Ground	
TMS	10R	JTAG Test Mode Select	
TDI	11R	JTAG Test Data Input	
TCK	2R	JTAG Test Clock	
TDO	1R	JTAG Test Data Output	
NC	3A,9A,6C,1H	No Connect	3

Notes: 1. C, \overline{C} , K or \overline{K} cannot be set to VREF voltage.

2. When ZQ pin is directly connected to VDD output impedance is set to minimum value and it cannot be connected to ground or left unconnected.

3. Not connected to chip pad internally.

GENERAL DESCRIPTION

The K7Q163664B and K7Q161864B are 18,874,368-bits QDR(Quad Data Rate) Synchronous Pipelined Burst SRAMs. They are organized as 524,288 words by 36bits for K7Q163664B and 1,048,576 words by 18 bits for K7Q161864B.

The QDR operation is possible by supporting DDR read and write operations through separate data output and input ports with the same cycle. Memory bandwidth is maximized as data can be transferred into sram on every rising edge of K and \bar{K} , and transferred out of sram on every rising edge of C and \bar{C} . And totally independent read and write ports eliminate the need for high speed bus turn around.

Address for read and write are latched on alternate rising edges of the input clock K. Data inputs, and all control signals are synchronized to the input clock (K or \bar{K}). Normally data outputs are synchronized to output clocks (C and \bar{C}), but when C and \bar{C} are tied high, the data outputs are synchronized to the input clocks (K and \bar{K}). Common address bus is used to access address both for read and write operations.

The internal burst counter is fixed to 4-bit sequential for both read and write operations, requiring two full clock bus cycles. Any request that attempts to interrupt a burst operation in progress is ignored. Synchronous pipeline read and late write enable high speed operations. Simple depth expansion is accomplished by using \bar{R} and \bar{W} for port selection. Byte write operation is supported with \bar{BW}_0 and \bar{BW}_1 (\bar{BW}_2 and \bar{BW}_3) pins. IEEE 1149.1 serial boundary scan (JTAG) simplifies monitoring package pads attachment status with system.

The K7Q163664B and K7Q161864B are implemented with SAMSUNG's high performance 6T CMOS technology and is available in 165pin FBGA packages. Multiple power and ground pins minimize ground bounce.

Read Operations

Read cycles are initiated by activating \bar{R} at the rising edge of the positive input clock K. Address is presented and stored in the read address register synchronized with K clock.

For 4-bit burst DDR operation, it will access four 36-bit or 18-bit data words with each read command. The first pipelined data is transferred out of the device triggered by C clock following next K clock rising edge. Next burst data is triggered by the rising edge of following \bar{C} clock rising edge. The process continues until all four data are transferred.

Continuous read operations are initiated with K clock rising edge. And pipelined data are transferred out of device on every rising edge of both C and \bar{C} clocks. In case C and \bar{C} tied to high, output data are triggered by K and \bar{K} instead of C and \bar{C} .

When the \bar{R} is disabled after a read operation, the K7Q163664B and K7Q161864B will first complete burst read operation before entering into deselect mode at the next K clock rising edge. Then output drivers disabled automatically to high impedance state.

Power-Up/Power-Down Supply Voltage Sequencing

The following power-up supply voltage application is recommended: VSS, VDD, VDDQ, VREF, then VIN. VDD and VDDQ can be applied simultaneously, as long as VDDQ does not exceed VDD by more than 0.5V during power-up. The following power-down supply voltage removal sequence is recommended: VIN, VREF, VDDQ, VDD, VSS. VDD and VDDQ can be removed simultaneously, as long as VDDQ does not exceed VDD by more than 0.5V during power-down.

Write Operations

Write cycles are initiated by activating \overline{W} at the rising edge of the positive input clock K.
Address is presented and stored in the write address register synchronized with K clock.

For 4-bit burst DDR operation, it will write four 36-bit or 18-bit data words with each write command.
The first "late" data is transferred and registered in to the device synchronous with next K clock rising edge.
Next burst data is transferred and registered synchronous with following \overline{K} clock rising edge.
The process continues until all four data are transferred and registered.

Continuous write operations are initiated with K rising edge.
And "late written" data is presented to the device on every rising edge of both K and \overline{K} clocks.

The device disregards input data presented on the same cycle \overline{W} disabled.
When the \overline{W} is disabled after a read operation, the K7Q163664B and K7Q161864B will first complete burst read operation before entering into deselect mode at the next K clock rising edge.

The K7Q163664B and K7Q161864B support byte write operations.
With activating \overline{BW}_0 or \overline{BW}_1 (\overline{BW}_2 or \overline{BW}_3) in write cycle, only one byte of input data is presented.
In K7Q161864B, \overline{BW}_0 controls write operation to D0:D8, \overline{BW}_1 controls write operation to D9:D17.
And in K7Q163664B \overline{BW}_2 controls write operation to D18:D26, \overline{BW}_3 controls write operation to D27:D35.

Programmable Impedance Output Buffer Operation

The designer can program the SRAM's output buffer impedance by terminating the ZQ pin to Vss through a precision resistor(RQ).
The value of RQ (within 15%) is five times the output impedance desired.

For example, 250Ω resistor will give an output impedance of 50Ω.
Impedance updates occur early in cycles that do not activate the outputs, such as deselect cycles.
In all cases impedance updates are transparent to the user and do not produce access time "push-outs" or other anomalous behavior in the SRAM.

There are no power up requirements for the SRAM. However, to guarantee optimum output driver impedance after power up, the SRAM needs 1024 non-read cycles.

Single Clock Mode

The K7Q163664B and K7Q161864B can be used with the single clock pair K and \overline{K} .
In this mode, C and \overline{C} must be tied high during power up and this single clock pair control both the input and output registers.
C and \overline{C} cannot be tied high during operation.
System flight time and clock skew could not be compensated in single clock mode.

Depth Expansion

Separate input and output ports enables easy depth expansion.
Each port can be selected and deselected independently
and read and write operation do not affect each other.
Before chip deselected, all read and write pending operations are completed.

STATE DIAGRAM

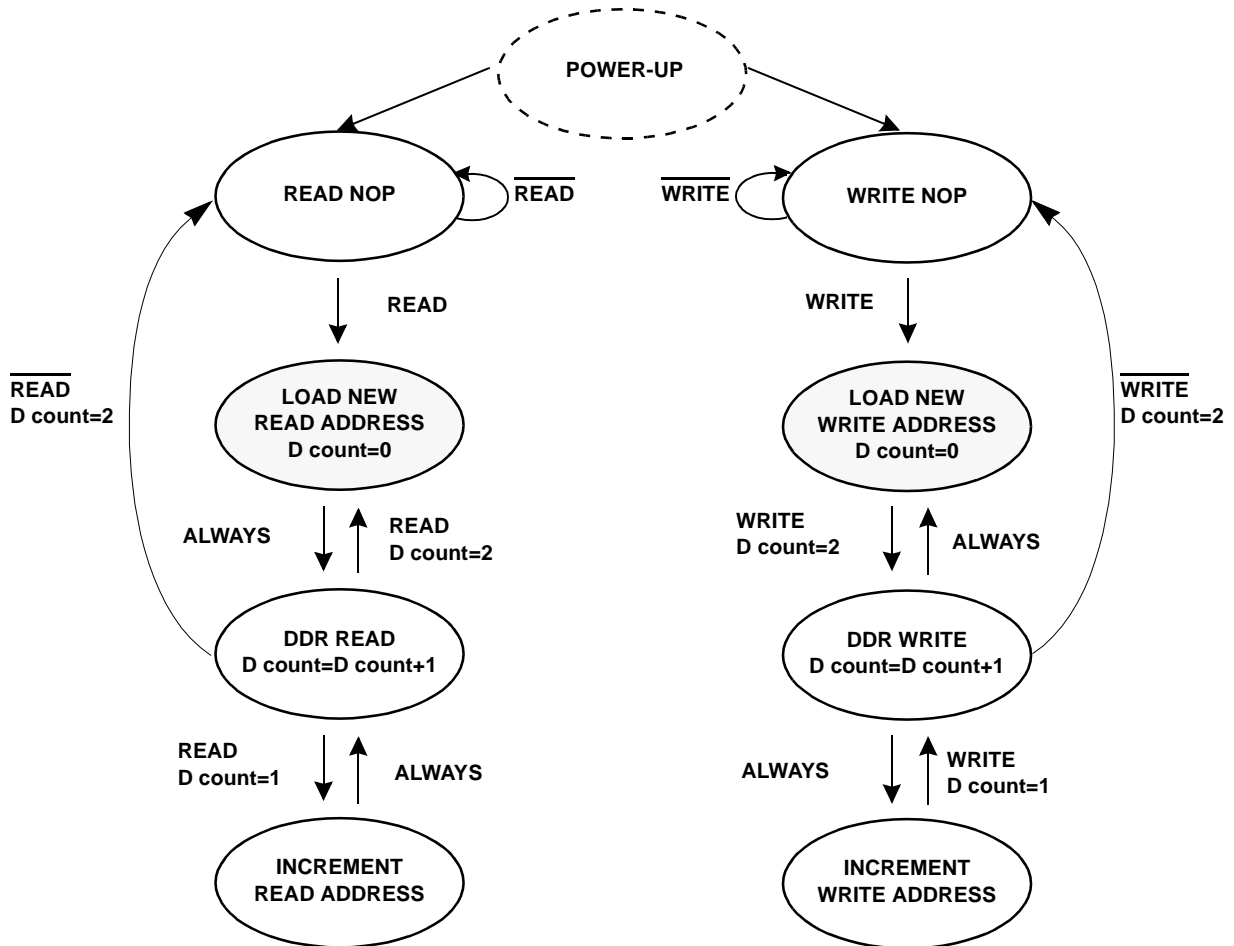

- Notes:**
1. Internal burst counter is fixed as 2-bit linear, i.e. when first address is A0+0, next internal burst address is A0+1.
 2. "READ" refers to read active status with \overline{R} =Low, " \overline{READ} " refers to read inactive status with \overline{R} =high. "WRITE" and " \overline{WRITE} " are the same case.
 3. Read and write state machine can be active simultaneously.
 4. State machine control timing sequence is controlled by K.

TRUTH TABLES

SYNCHRONOUS TRUTH TABLE

K	\bar{R}	\bar{W}	D				Q				OPERATION	
			D(A1)	D(A2)	D(A3)	D(A4)	Q(A1)	Q(A2)	Q(A3)	Q(A4)		
Stopped	X	X	Previous state	Previous state	Previous state	Previous state	Previous state	Previous state	Previous state	Previous state	Previous state	Clock Stop
↑	H	H	X	X	X	X	High-Z	High-Z	High-Z	High-Z	High-Z	No Operation
↑	L	X	X	X	X	X	Dout at C(t+1)	Dout at $\bar{C}(t+1)$	Dout at C(t+2)	Dout at $\bar{C}(t+2)$	Dout at $\bar{C}(t+2)$	Read
↑	H	L	Din at K(t+1)	Din at $\bar{K}(t+1)$	Din at K(t+2)	Din at $\bar{K}(t+2)$	X	X	X	X	X	Write

- Notes:** 1. X means "Don't Care".
 2. The rising edge of clock is symbolized by (↑).
 3. Before enter into clock stop status, all pending read and write operations will be completed.

WRITE TRUTH TABLE(x18)

K	\bar{K}	\bar{W}	\bar{BW}_0	\bar{BW}_1	OPERATION
↑		H	X	X	READ/NOP
	↑	H	X	X	READ/NOP
↑		L	L	L	WRITE ALL BYTES (K↑)
	↑	L	L	L	WRITE ALL BYTES (\bar{K} ↑)
↑		L	L	H	WRITE BYTE 0 (K↑)
	↑	L	L	H	WRITE BYTE 0 (\bar{K} ↑)
↑		L	H	L	WRITE BYTE 1 (K↑)
	↑	L	H	L	WRITE BYTE 1 (\bar{K} ↑)
↑		L	H	H	WRITE NOTHING (K↑)
	↑	L	H	H	WRITE NOTHING (\bar{K} ↑)

- Notes:** 1. X means "Don't Care".
 2. All inputs in this table must meet setup and hold time around the rising edge of CLK(↑).

WRITE TRUTH TABLE(x36)

K	\bar{K}	\bar{W}	\bar{BW}_0	\bar{BW}_1	\bar{BW}_2	\bar{BW}_3	OPERATION
↑		H	X	X	X	X	READ/NOP
	↑	H	X	X	X	X	READ/NOP
↑		L	L	L	L	L	WRITE ALL BYTES (K↑)
	↑	L	L	L	L	L	WRITE ALL BYTES (\bar{K} ↑)
↑		L	L	H	H	H	WRITE BYTE 0 (K↑)
	↑	L	L	H	H	H	WRITE BYTE 0 (\bar{K} ↑)
↑		L	H	L	H	H	WRITE BYTE 1 (K↑)
	↑	L	H	L	H	H	WRITE BYTE 1 (\bar{K} ↑)
↑		L	H	H	L	L	WRITE BYTE 2 and BYTE 3 (K↑)
	↑	L	H	H	L	L	WRITE BYTE 2 and BYTE 3 (\bar{K} ↑)
↑		L	H	H	H	H	WRITE NOTHING (K↑)
	↑	L	H	H	H	H	WRITE NOTHING (\bar{K} ↑)

- Notes:** 1. X means "Don't Care".
 2. All inputs in this table must meet setup and hold time around the rising edge of CLK(↑).

ABSOLUTE MAXIMUM RATINGS*

PARAMETER	SYMBOL	RATING	UNIT
Voltage on V _{DD} Supply Relative to V _{SS}	V _{DD}	-0.5 to 3.6	V
Voltage on V _{DDQ} Supply Relative to V _{SS}	V _{DDQ}	-0.5 to V _{DD}	V
Voltage on Input Pin Relative to V _{SS}	V _{IN}	-0.5 to V _{DD} +0.3	V
Storage Temperature	T _{STG}	-65 to 150	°C
Operating Temperature	T _{OPR}	0 to 70	°C
Storage Temperature Range Under Bias	T _{BIAS}	-10 to 85	°C

- *Note: 1. Stresses greater than those listed under "Absolute Maximum Ratings" may cause permanent damage to the device. This is a stress rating only and functional operation of the device at these or any other conditions above those indicated in the operating sections of this specification is not implied. Exposure to absolute maximum rating conditions for extended periods may affect reliability.
2. V_{DDQ} must not exceed V_{DD} during normal operation.

DC ELECTRICAL CHARACTERISTICS

PARAMETER	SYMBOL	TEST CONDITIONS	MIN	MAX	UNIT	NOTES
Input Leakage Current	I _{IL}	V _{DD} =Max ; V _{IN} =V _{SS} to V _{DDQ}	-2	+2	μA	
Output Leakage Current	I _{OL}	Output Disabled,	-2	+2	μA	
Operating Current (x36) : DDR	I _{CC}	V _{DD} =Max , I _{OUT} =0mA Cycle Time ≥ t _{KHKKH} Min	-16	-	400	mA 1,5
Operating Current (x18) : DDR	I _{CC}	V _{DD} =Max , I _{OUT} =0mA Cycle Time ≥ t _{KHKKH} Min	-16	-	300	mA 1,5
Standby Current(NOP) : DDR	I _{SB1}	Device deselected, I _{OUT} =0mA, f=Max, All Inputs ≤ 0.2V or ≥ V _{DD} -0.2V	-16	-	170	mA 1,6
Output High Voltage	V _{OH1}		V _{DDQ} /2	V _{DDQ}	V	2,7
Output Low Voltage	V _{OL1}		V _{SS}	V _{DDQ} /2	V	3,7
Output High Voltage	V _{OH2}	I _{OH} =-1.0mA	V _{DDQ} -0.2	V _{DDQ}	V	4
Output Low Voltage	V _{OL2}	I _{OL} =1.0mA	V _{SS}	0.2	V	4
Input Low Voltage	V _{IL}		-0.3	V _{REF} -0.1	V	8,9
Input High Voltage	V _{IH}		V _{REF} +0.1	V _{DDQ} +0.3	V	8,10

- Notes: 1. Minimum cycle. I_{OUT}=0mA.
2. |I_{OH}|=(V_{DDQ}/2)/(R_Q/5)±15% @ V_{OH}=V_{DDQ}/2 for 175Ω ≤ R_Q ≤ 350Ω.
3. |I_{OL}|=(V_{DDQ}/2)/(R_Q/5)±15% @ V_{OL}=V_{DDQ}/2 for 175Ω ≤ R_Q ≤ 350Ω.
4. Minimum Impedance Mode when ZQ pin is connected to V_{DD}.
5. Operating current is calculated with 50% read cycles and 50% write cycles.
6. Standby Current is only after all pending read and write burst operations are completed.
7. Programmable Impedance Mode.
8. These are DC test criteria. DC design criteria is V_{REF}±50mV. The AC V_{IH}/V_{IL} levels are defined separately for measuring timing parameters.
9. V_{IL} (Min)DC=-0.3V, V_{IL} (Min)AC=-1.5V(pulse width ≤ 3ns).
10. V_{IH} (Max)DC=V_{DDQ}+0.3, V_{IH} (Max)AC=V_{DDQ}+0.85V(pulse width ≤ 3ns).

Overshoot Timing

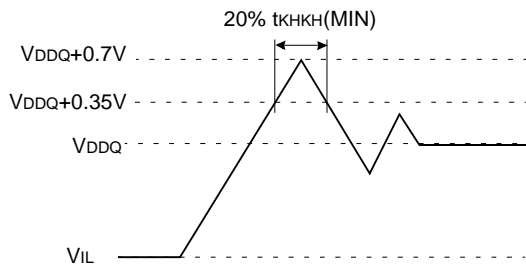

Undershoot Timing

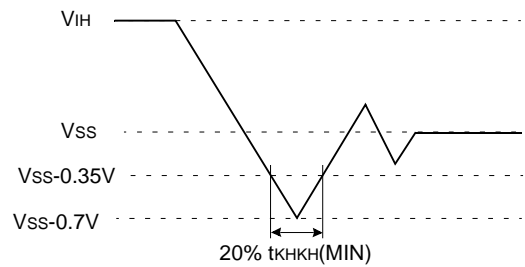

RECOMMENDED DC OPERATING CONDITIONS ($0^{\circ}C \leq T_A \leq 70^{\circ}C$)

PARAMETER	SYMBOL	MIN	TYP	MAX	UNIT
Supply Voltage	V_{DD}	1.7	2.5	2.6	V
	V_{DDQ}	1.4	1.5	1.9	V
Reference Voltage	V_{REF}	0.68	0.75	0.95	V
Ground	V_{SS}	0	0	0	V

AC TIMING CHARACTERISTICS

PARAMETER	SYMBOL	-16		UNITS	NOTES
		MIN	MAX		
Clock					
Clock Cycle Time (K, \bar{K}, C, \bar{C})	t_{KHKH}	6.0		ns	
Clock HIGH time (K, \bar{K}, C, \bar{C})	t_{KHKL}	2.4		ns	
Clock LOW time (K, \bar{K}, C, \bar{C})	t_{KLKH}	2.4		ns	
Clock to clock ($K \uparrow \rightarrow \bar{K} \uparrow, C \uparrow \rightarrow \bar{C} \uparrow$)	$t_{KH\bar{K}H}$	2.7	3.3	ns	
Clock to data clock ($K \uparrow \rightarrow C \uparrow, \bar{K} \uparrow \rightarrow \bar{C} \uparrow$)	t_{KHCH}	0.0	2.0	ns	
Output Times					
C, \bar{C} High to Output Valid	t_{CHQV}		2.5	ns	3
C, \bar{C} High to Output hold	t_{CHQX}	1.2		ns	3
C High to Output High-Z	t_{CHQZ}		2.5	ns	3
C High to Output Low-Z	t_{CHQX1}	1.2		ns	3
Setup Times					
Address valid to K rising edge	t_{AVKH}	0.7		ns	
Control inputs valid to K rising edge	t_{IVKH}	0.7		ns	2
Data-in valid to K, \bar{K} rising edge	t_{DVKH}	0.7		ns	
Hold Times					
K rising edge to address hold	t_{KHAX}	0.7		v	
K rising edge to control inputs hold	t_{KHIX}	0.7		ns	
K, \bar{K} rising edge to data-in hold	t_{KHDX}	0.7		ns	

- Notes:**
- All address inputs must meet the specified setup and hold times for all latching clock edges.
 - Control signals are R, \bar{W}, BW_0, BW_1 and (BW_2, BW_3 , also for x36)
 - If C, \bar{C} are tied high, K, \bar{K} become the references for C, \bar{C} timing parameters.
 - To avoid bus contention, at a given voltage and temperature t_{CHQX1} is bigger than t_{CHQZ} .
The specs as shown do not imply bus contention because t_{CHQX1} is a MIN parameter that is worst case at totally different test conditions ($0^{\circ}C, 2.6V$) than t_{CHQZ} , which is a MAX parameter (worst case at $70^{\circ}C, 2.4V$)
It is not possible for two SRAMs on the same board to be at such different voltage and temperature.

TIMING WAVE FORMS OF READ AND NOP

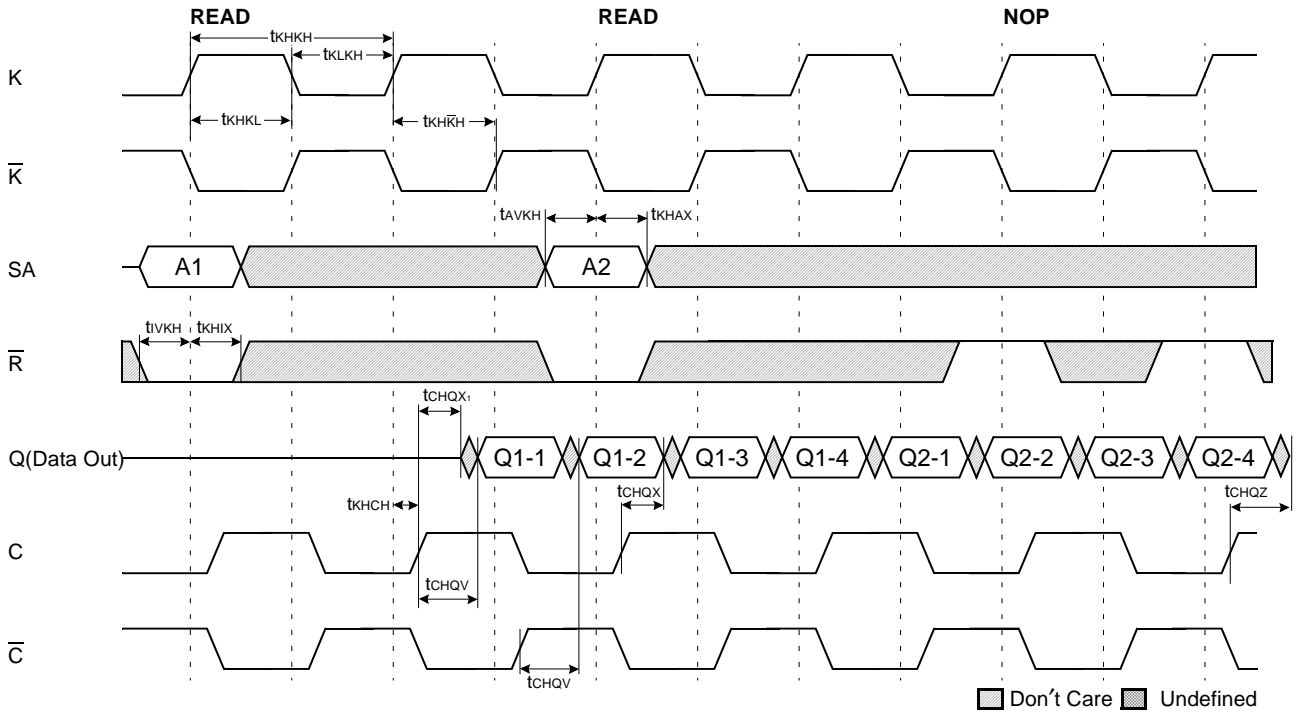

Note: 1. Q1-1 refers to output from address A1+0, Q1-2 refers to output from address A1+1 i.e. the next internal burst address following A1+0.
 2. Outputs are disabled one cycle after a NOP.

TIMING WAVE FORMS OF WRITE AND NOP

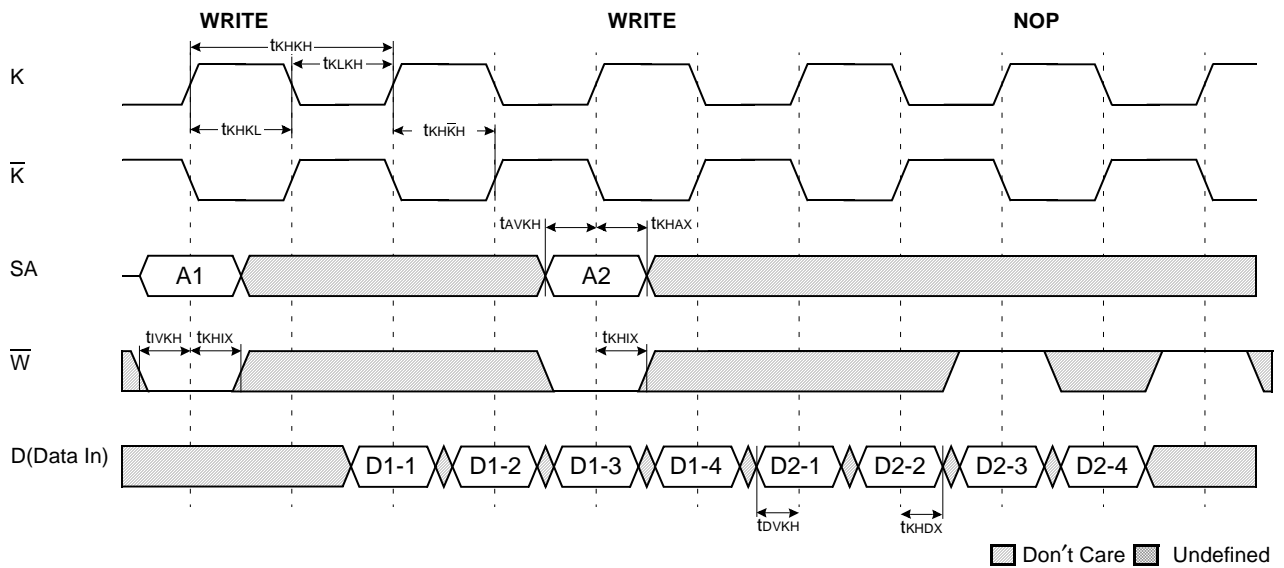

Note: 1. D1-1 refers to input to address A1+0, D1-2 refers to input to address A1+1, i.e. the next internal burst address following A1+0.

TIMING WAVE FORMS OF READ, WRITE AND NOP

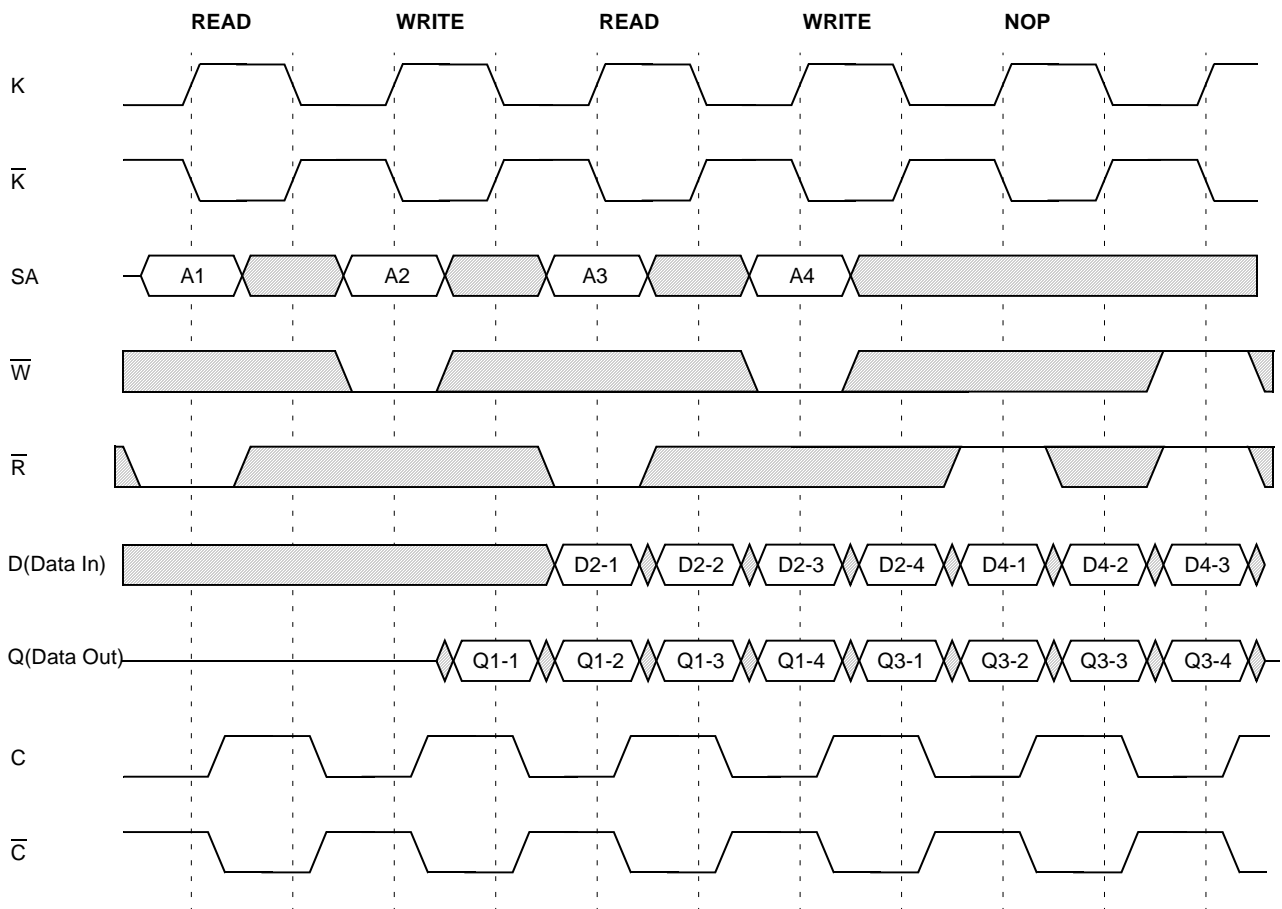

□ Don't Care ■ Undefined

- Note:**
1. Q1-1 refers to output from address A1+0, Q1-2 refers to output from address A1+1 i.e. the next internal burst address following A1+0.
 2. Outputs are disabled one cycle after a NOP.
 3. If address A3=A2, data Q3-1=D2-1, data Q3-2=D2-2, data Q3-3=D2-3, data Q3-4=D2-4.
Write data is forwarded immediately as read results.
 4. \overline{Wx} assumed active

IEEE 1149.1 TEST ACCESS PORT AND BOUNDARY SCAN-JTAG

This part contains an IEEE standard 1149.1 Compatible Test Access Port(TAP). The package pads are monitored by the Serial Scan circuitry when in test mode. This is to support connectivity testing during manufacturing and system diagnostics. Internal data is not driven out of the SRAM under JTAG control. In conformance with IEEE 1149.1, the SRAM contains a TAP controller, Instruction Register, Bypass Register and ID register. The TAP controller has a standard 16-state machine that resets internally upon power-up, therefore, TRST signal is not required. It is possible to use this device without utilizing the TAP. To disable the TAP controller without interfacing with normal operation of the SRAM, TCK must be tied to Vss to preclude mid level input. TMS and TDI are designed so an undriven input will produce a response identical to the application of a logic 1, and may be left unconnected. But they may also be tied to VDD through a resistor. TDO should be left unconnected.

JTAG Block Diagram

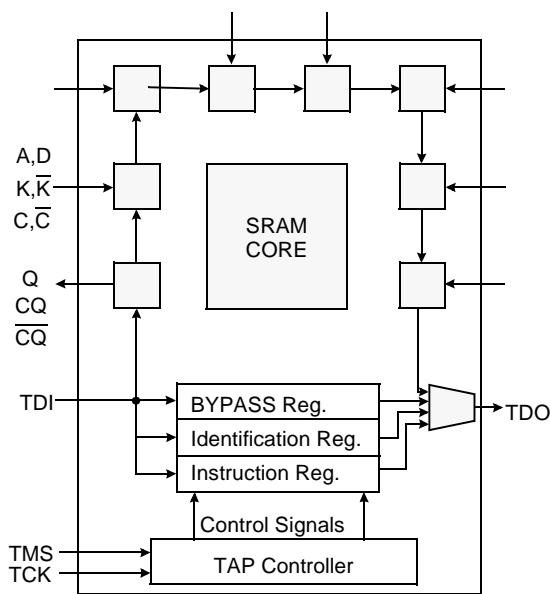

JTAG Instruction Coding

IR2	IR1	IR0	Instruction	TDO Output	Notes
0	0	0	EXTEST	Boundary Scan Register	1
0	0	1	IDCODE	Identification Register	3
0	1	0	SAMPLE-Z	Boundary Scan Register	2
0	1	1	RESERVED	Do Not Use	6
1	0	0	SAMPLE	Boundary Scan Register	5
1	0	1	RESERVED	Do Not Use	6
1	1	0	RESERVED	Do Not Use	6
1	1	1	BYPASS	Bypass Register	4

NOTE :

1. Places DQs in Hi-Z in order to sample all input data regardless of other SRAM inputs. This instruction is not IEEE 1149.1 compliant.
2. Places DQs in Hi-Z in order to sample all input data regardless of other SRAM inputs.
3. TDI is sampled as an input to the first ID register to allow for the serial shift of the external TDI data.
4. Bypass register is initiated to Vss when BYPASS instruction is invoked. The Bypass Register also holds serially loaded TDI when exiting the Shift DR states.
5. SAMPLE instruction dose not places DQs in Hi-Z.
6. This instruction is reserved for future use.

TAP Controller State Diagram

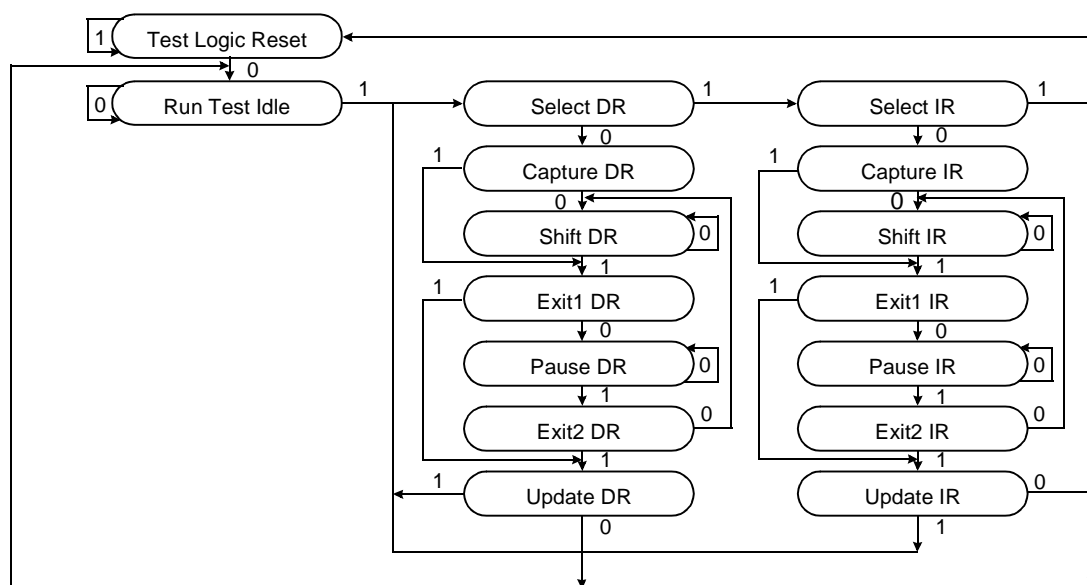

SCAN REGISTER DEFINITION

Part	Instruction Register	Bypass Register	ID Register	Boundary Scan
512Kx36	3 bits	1 bit	32 bits	107 bits
1Mx18	3 bits	1 bit	32 bits	107 bits

ID REGISTER DEFINITION

Part	Revision Number (31:29)	Part Configuration (28:12)	Samsung JEDEC Code (11: 1)	Start Bit(0)
512Kx36	000	00def0wx0t0q0b0s0	00001001110	1
1Mx18	000	00def0wx0t0q0b0s0	00001001110	1

Note : Part Configuration

/def=001 for 18Mb, /wx=11 for x36, 10 for x18.

/t=Don't Care. /q=1 for QDR, 0 for DDR /b=1 for 4Bit Burst, 0 for 2Bit Burst /s=1 for Separate I/O, 0 for Common I/O

BOUNDARY SCAN EXIT ORDER

ORDER	PIN ID
1	6R
2	6P
3	6N
4	7P
5	7N
6	7R
7	8R
8	8P
9	9R
10	11P
11	10P
12	10N
13	9P
14	10M
15	11N
16	9M
17	9N
18	11L
19	11M
20	9L
21	10L
22	11K
23	10K
24	9J
25	9K
26	10J
27	11J
28	11H
29	10G
30	9G
31	11F
32	11G
33	9F
34	10F
35	11E
36	10E

ORDER	PIN ID
37	10D
38	9E
39	10C
40	11D
41	9C
42	9D
43	11B
44	11C
45	9B
46	10B
47	11A
48	Internal
49	9A
50	8B
51	7C
52	6C
53	8A
54	7A
55	7B
56	6B
57	6A
58	5B
59	5A
60	4A
61	5C
62	4B
63	3A
64	1H
65	1A
66	2B
67	3B
68	1C
69	1B
70	3D
71	3C
72	1D

ORDER	PIN ID
73	2C
74	3E
75	2D
76	2E
77	1E
78	2F
79	3F
80	1G
81	1F
82	3G
83	2G
84	1J
85	2J
86	3K
87	3J
88	2K
89	1K
90	2L
91	3L
92	1M
93	1L
94	3N
95	3M
96	1N
97	2M
98	3P
99	2N
100	2P
101	1P
102	3R
103	4R
104	4P
105	5P
106	5N
107	5R

Note: 1. NC pins are read as "X" (i.e. don't care.)

JTAG DC OPERATING CONDITIONS

Parameter	Symbol	Min	Typ	Max	Unit	Note
Power Supply Voltage	V _{DD}	1.7	2.5	2.6	V	
Input High Level	V _{IH}	0.7*V _{DD}	-	V _{DD} +0.3	V	
Input Low Level	V _{IL}	-0.3	-	0.3*V _{DD}	V	
Output High Voltage(I _{OH} =-2mA)	V _{OH}	0.75*V _{DD}	-	V _{DD}	V	
Output Low Voltage(I _{OL} =2mA)	V _{OL}	V _{SS}	-	0.25*V _{DD}	V	

Note: 1. The input level of SRAM pin is to follow the SRAM DC specification.

JTAG AC TEST CONDITIONS

Parameter	Symbol	Min	Unit	Note
Input High/Low Level	V _{IH} /V _{IL}	V _{DD} /0.0	V	
Input Rise/Fall Time	T _R /T _F	1.0/1.0	ns	
Input and Output Timing Reference Level		V _{DD} /2	V	1

Note: 1. See SRAM AC test output load on page 11.

JTAG AC Characteristics

Parameter	Symbol	Min	Max	Unit	Note
TCK Cycle Time	t _{CHCH}	50	-	ns	
TCK High Pulse Width	t _{CHCL}	20	-	ns	
TCK Low Pulse Width	t _{CLCH}	20	-	ns	
TMS Input Setup Time	t _{MVCH}	5	-	ns	
TMS Input Hold Time	t _{CHMX}	5	-	ns	
TDI Input Setup Time	t _{DVCH}	5	-	ns	
TDI Input Hold Time	t _{CHDX}	5	-	ns	
SRAM Input Setup Time	t _{SVCH}	5	-	ns	
SRAM Input Hold Time	t _{CHSX}	5	-	ns	
Clock Low to Output Valid	t _{CLQV}	0	10	ns	

JTAG TIMING DIAGRAM

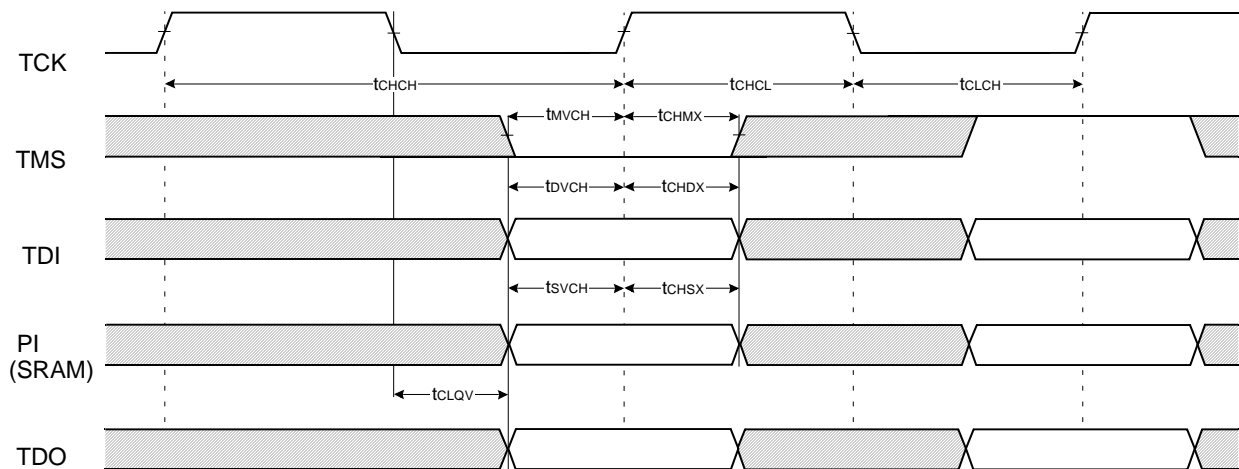

165 FBGA PACKAGE DIMENSIONS

13mm x 15mm Body, 1.0mm Bump Pitch, 11x15 Ball Array

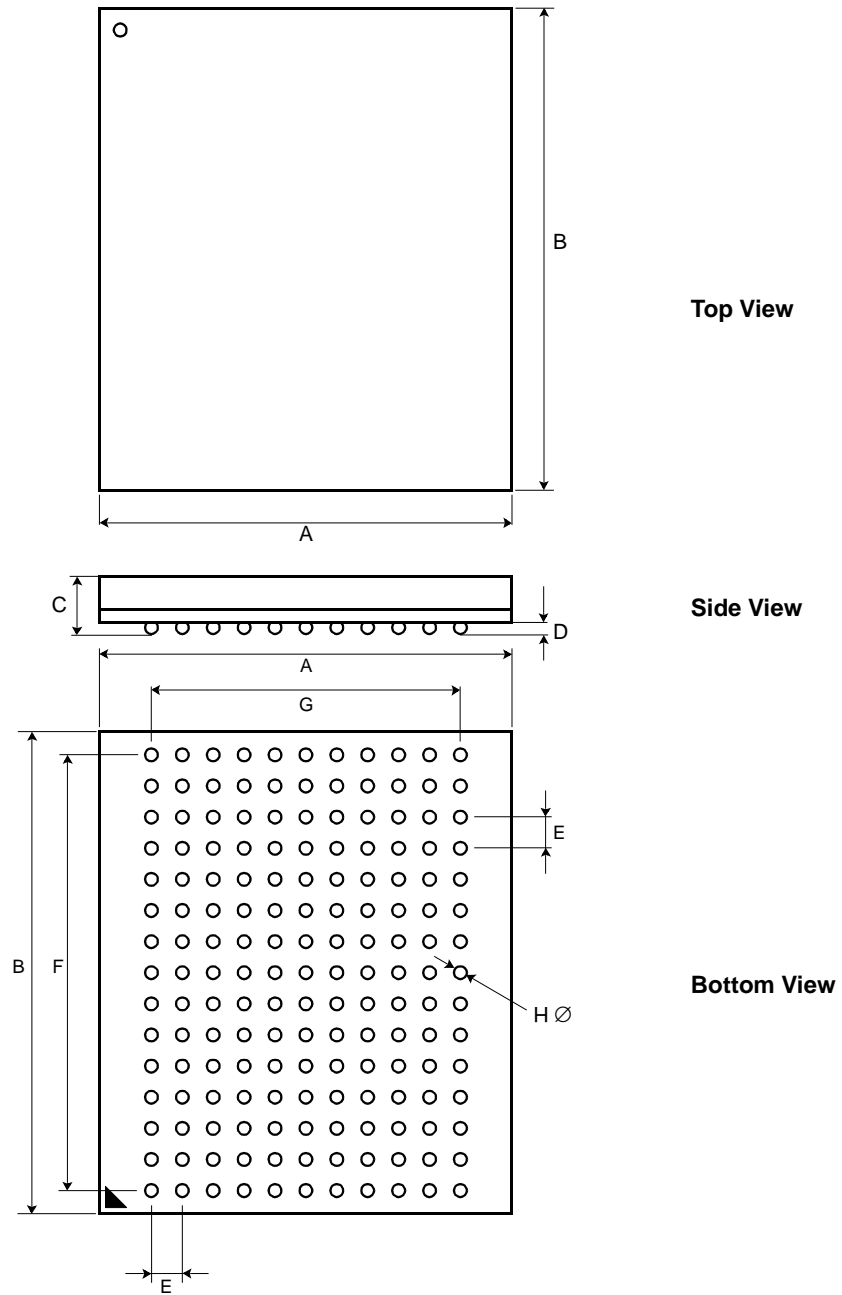

Symbol	Value	Units	Note	Symbol	Value	Units	Note
A	13 ± 0.1	mm		E	1.0	mm	
B	15 ± 0.1	mm		F	14.0	mm	
C	1.3 ± 0.1	mm		G	10.0	mm	
D	0.35 ± 0.05	mm		H	0.5 ± 0.05	mm	