



## Four-Bit Single-Chip Microcontroller with 16 KB of On-Chip OTP PROM

### Preliminary

### Overview

The LC66P2316 is an on-chip OTP PROM version of the LC6623XX Series CMOS 4-bit single-chip microcontrollers. The LC66P2316 is appropriate for program development and product evaluation since it provides identical functionality and pin compatibility with the LC662316A.

### Features and Functions

- On-chip OTP ROM capacity of 16 kilobytes, and an on-chip RAM capacity of  $512 \times 4$  bits.
- Fully supports the LC66000 Series common instruction set (128 instructions).
- I/O ports: 36 pins
- DTMF generator
 

This microcontroller incorporates a circuit that can generate two sine wave outputs, DTMF output, or a melody output for software applications.
- 8-bit serial interface: one circuit
- Instruction cycle time: 0.95 to 10  $\mu$ s (at 4.0 to 5.5 V)
- Powerful timer functions and prescalers
  - Time limit timer, event counter, pulse width measurement, and square wave output using a 12-bit timer.
  - Time limit timer, event counter, PWM output, and square wave output using an 8-bit timer.
  - Time base function using a 12-bit prescaler.
- Powerful interrupt system with 10 interrupt factors and 7 interrupt vector locations.
  - External interrupts: 3 factors/3 vector locations
  - Internal interrupts: 4 factors/4 vector locations (Waveform output internal interrupts: 3 factors and 1 vector; shared with external expansion interrupts)
- Flexible I/O functions
 

Selectable options include 20-mA drive outputs, inverter circuits, pull-up and open drain circuits.
- Optional runaway detection function (watchdog timer)
- 8-bit I/O functions
- Power saving functions using halt and hold modes.
- Packages: DIP42S, QIP48E (QFP48E)
- Evaluation LSIs: LC66599 (evaluation chip) + EVA800/850-TB662YXX2

### Package Dimensions

unit: mm

#### 3025B-DIP42S

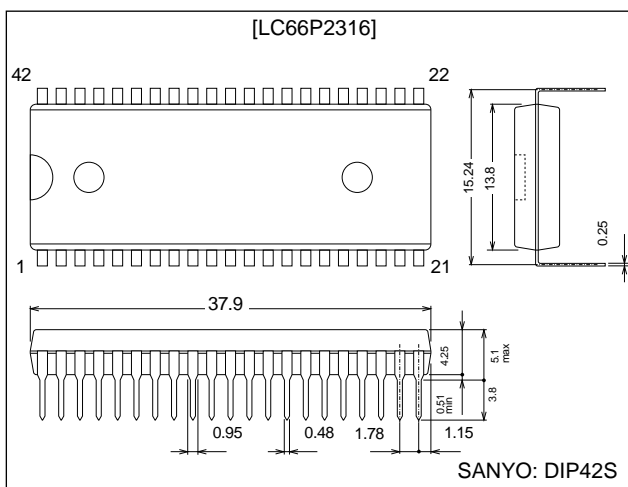

unit: mm

#### 3156-QFP48E

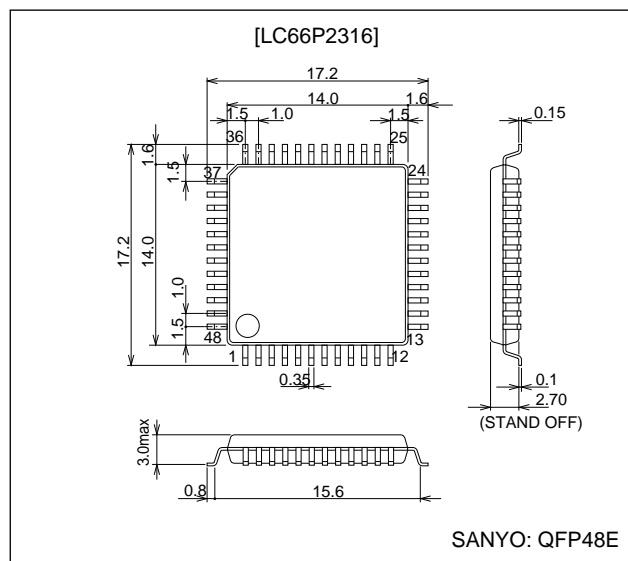

## Series Organization

Type No.	No. of pins	ROM capacity	RAM capacity	Package		Features
LC66304A/306A/308A	42	4 K/6 K/8 KB	512 W	DIP42S	QFP48E	Normal versions 4.0 to 6.0 V/0.92 $\mu$ s
LC66404A/406A/408A	42	4 K/6 K/8 KB	512 W	DIP42S	QFP48E	
LC66506B/508B/512B/516B	64	6 K/8 K/12 K/16 KB	512 W	DIP64S	QFP64A	
LC66354A/356A/358A	42	4 K/6 K/8 KB	512 W	DIP42S	QFP48E	Low-voltage versions 2.2 to 5.5 V/3.92 $\mu$ s
LC66354S/356S/358S	42	4 K/6 K/8 KB	512 W		QFP44M	
LC66556A/558A/562A/566A	64	6 K/8 K/12 K/16 KB	512 W	DIP64S	QFP64E	Low-voltage high-speed versions 3.0 to 5.5 V/0.92 $\mu$ s
LC66354B/356B/358B	42	4 K/6 K/8 KB	512 W	DIP42S	QFP48E	
LC66556B/558B/562B/566B	64	6 K/8 K/12 K/16 KB	512 W	DIP64S	QFP64E	----- 2.5 to 5.5 V/0.92 $\mu$ s
LC66354C/356C/358C	42	4 K/6 K/8 KB	512 W	DIP42S	QFP48E	
LC662104A/06A/08A	30	4 K/6 K/8 KB	384 W	DIP30SD	MFP30S	On-chip DTMF generator versions 3.0 to 5.5 V/0.95 $\mu$ s
LC662304A/06A/08A/12A/16A	42	4 K/6 K/8 K/12 K/16 KB	512 W	DIP42S	QFP48E	
LC662508A/12A/16A	64	8 K/12 K/16 KB	512 W	DIP64S	QFP64E	
LC665304A/06A/08A/12A/16A	48	4 K/6 K/8 K/12 K/16 KB	512 W	DIP48S	QFP48E	Dual oscillator support 3.0 to 5.5 V/0.95 $\mu$ s
LC66E308	42	EPROM 8 KB	512 W	DIC42S with window	QFC48 with window	Window and OTP evaluation versions 4.5 to 5.5 V/0.92 $\mu$ s
LC66P308	42	OTPROM 8 KB	512 W	DIP42S	QFP48E	
LC66E408	42	EPROM 8 KB	512 W	DIC42S with window	QFC48 with window	
LC66P408	42	OTPROM 8 KB	512 W	DIP42S	QFP48E	
LC66E516	64	EPROM 16 KB	512 W	DIC64S with window	QFC64 with window	
LC66P516	64	OTPROM 16 KB	512 W	DIP64S	QFP64E	
LC66E2108*	30	EPROM 8 KB	384 W			
LC66E2316	42	EPROM 16 KB	512 W	DIC42S with window	QFC48 with window	Window evaluation versions 4.5 to 5.5 V/0.92 $\mu$ s
LC66E2516	64	EPROM 16 KB	512 W	DIC64S with window	QFC64 with window	
LC66E5316	52/48	EPROM 16 KB	512 W	DIC52S with window	QFC48 with window	
LC66P2108*	30	OTPROM 8 KB	384 W	DIP30SD	MFP30S	OTP 4.0 to 5.5 V/0.95 $\mu$ s
LC66P2316*	42	OTPROM 16 KB	512 W	DIP42S	QFP48E	
LC66P2516	64	OTPROM 16 KB	512 W	DIP64S	QFP64E	
LC66P5316	48	OTPROM 16 KB	512 W	DIP48S	QFP48E	

Note: \* Under development

Pin Assignments

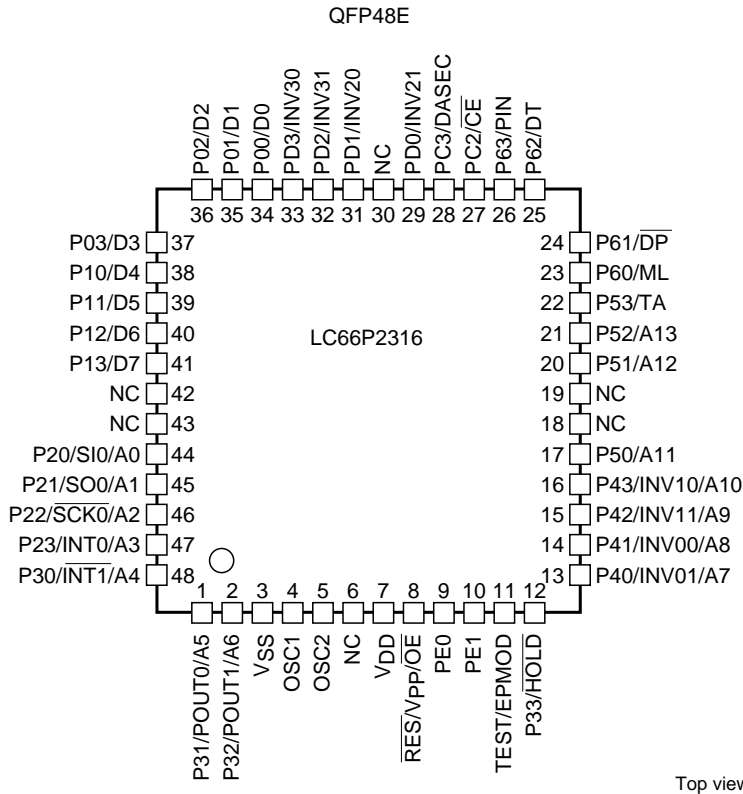
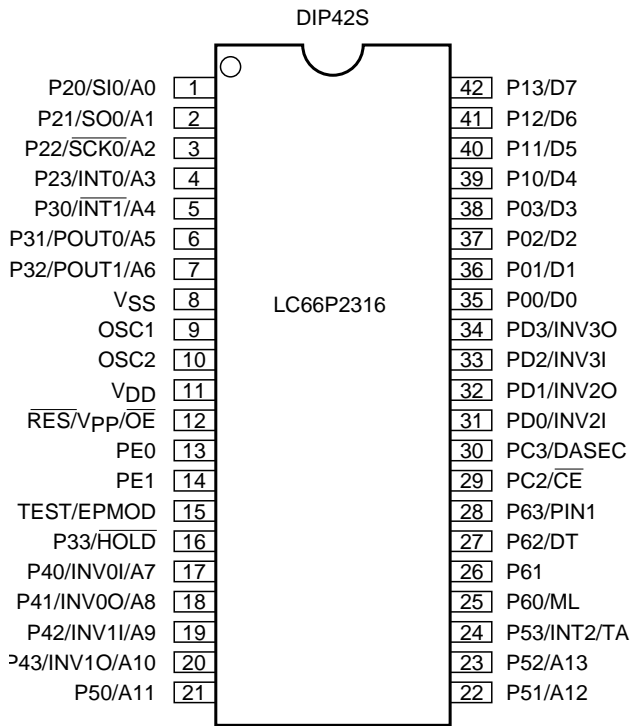

We recommend the use of reflow-soldering techniques to solder-mount QFP packages.

Please consult with your Sanyo representative for details on process conditions if the package itself is to be directly immersed in a dip-soldering bath (dip-soldering techniques).

## Usage Notes

The LC66P2316 was created for program development, product evaluation, and prototype development for products based on the LC6623XX Series microcontrollers. Keep the following points in mind when using this product.

### 1. After a reset

The  $\overline{\text{RES}}$  pin must be held low for an additional 3 instruction cycles after the oscillator stabilization period has elapsed. Also, the port output circuit types are set up during the 9 instruction cycles immediately after  $\overline{\text{RES}}$  is set high. Only then is the program counter set to 0 and program execution started from that location. (The port output circuits all revert to the open-drain type during periods when  $\overline{\text{RES}}$  is low.)

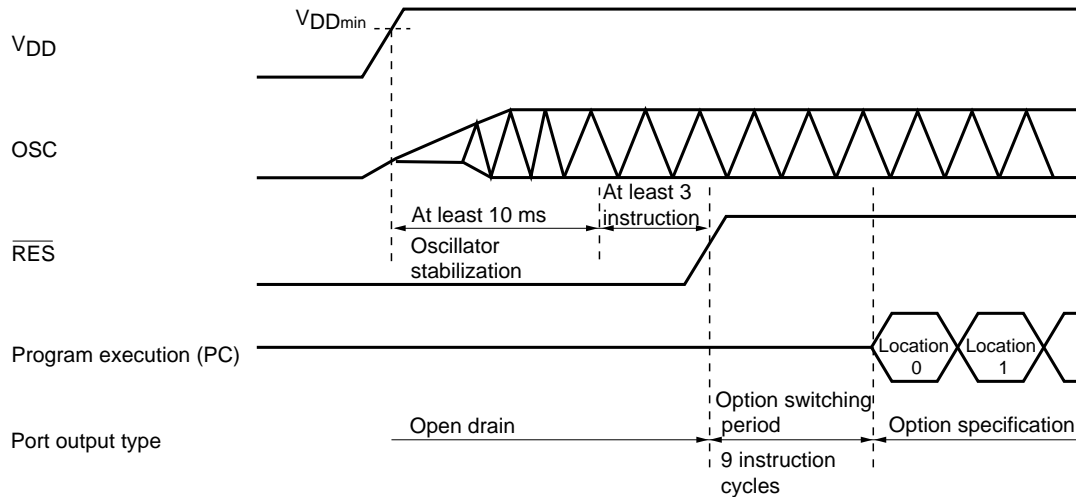

### 2. Notes on LC6623XX evaluation

The high end of the EPROM area (locations 3FF0H to 3FFFH) are the option specification area. Option specification data must be programmed for and loaded into this area. The Sanyo specified cross assembler for this product is the program LC66S.EXE. Also, insert JMP instructions so that user programs do not attempt to execute addresses that exceed the capacity of the mask ROM, and write zeros (00H) to areas (other than 3FF0H to 3FFFH) that exceed the actual capacity of the mask ROM.

### 3. Mounting notes

Due to structural considerations, Sanyo is unable to fully test one-time programmable products. Therefore, the user must apply the screening procedure described on page 20 to these products.

### 4. Use the following procedure when ordering ROM through the Sanyo PROM writing service. (Note that this is a for-fee service.)

- If ordering one-time programmable and mask ROM versions at the same time:

The customer must provide the EPROM for the mask ROM version, the order forms for the mask ROM version, and the order forms for the one-time programmable version.

- If ordering only the one-time programmable version:

The customer must provide the EPROM and the order forms for the one-time programmable version. The last section of the EPROM (locations 3FF0H to 3FFFH) is the option specification area, and the option specification data must be written to this area. The Sanyo specified cross assembler for this product is the program LC66S.EXE. Also, insert JMP instructions so that user programs do not attempt to execute addresses that exceed the capacity of the mask ROM, and write zeros (00H) to areas (other than 3FF0H to 3FFFH) that exceed the actual capacity of the mask ROM.

### 5. Differences between this product and the mask ROM version:

Carefully read the sections on the following pages that describe these differences.

Main differences between the LC66E2316, LC66P2316, and LC6623XX Series

Item	LC6623XX Series (mask version)	LC66E2316	LC66P2316
Differences in the main characteristics			
• Operating temperature range	-30 to +70°C	+10 to +40°C	-30 to +70°C
• Operating supply voltage/operating frequency (cycle time)	3.5 to 5.5 V/0.95 to 10 μs	4.5 to 5.5 V/0.95 to 10 μs	4.0 to 5.5 V/0.95 to 10 μs
• Input high-level current ( $\overline{RES}$ )	Maximum: 1 μA	Typical: 10 μA (normal operation and halt mode) Hold mode: 1 μA maximum	Typical: 10 μA (normal operation and halt mode) Hold mode: 1 μA maximum
• Input low-level current ( $RES$ )	Maximum: 1 μA	Typical: 100 μA	Typical: 100 μA
• Current drain (Operating at 4 MHz) (Halt mode at 4 MHz) (Hold mode)	Typical: 10 nA, maximum: 10 μA	Larger than that for the mask versions Typical: 10 nA, maximum: 10 μA*	Larger than that for the mask versions Typical: 10 nA, maximum: 10 μA*
Port output types at reset	The output type specified in the options	Open-drain outputs	Open-drain outputs
Package	• DIP42S • QFP48E	• DIC42S window package • QFC48 window package	• DIP42S • QFP48E

Note: \* Although the microcontroller will remain in hold mode if the  $\overline{RES}$  pin is set low while it is in hold mode, always use the reset start sequence (after switching HOLD from low to high, switch  $\overline{RES}$  from low to high) when clearing hold mode. Also not that a current of about 100 μA flows from the  $\overline{RES}$  pin when it is low. This increases the hold mode current drain by about 100 μA.

See the data sheets for the individual products for details on other differences.

System Block Diagram

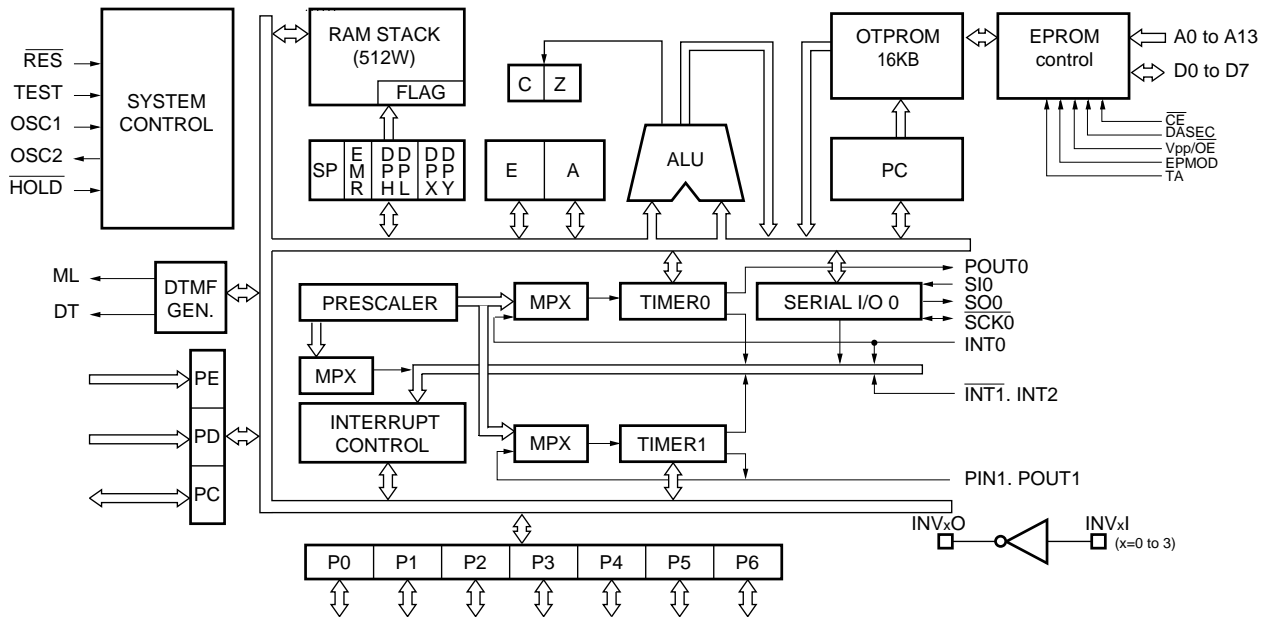

## Pin Function Overview

Pin	I/O	Overview	Output driver type	Options	State after a reset	Standby mode operation
P00/D0 P01/D1 P02/D2 P03/D3	I/O	I/O ports P00 to P03 <ul style="list-style-type: none"> <li>Input or output in 4-bit or 1-bit units</li> <li>P00 to P03 support the halt mode control function (This function can be specified in single-bit units.)</li> <li>Used as data pins in EPROM mode</li> </ul>	<ul style="list-style-type: none"> <li>Pch: Pull-up MOS type</li> <li>Nch: Intermediate sink current type</li> </ul>	<ul style="list-style-type: none"> <li>Pull-up MOS or Nch OD output</li> <li>Output level on reset</li> </ul>	High or low (option)	Hold mode: Output off ----- Halt mode: Output retained
P10/D4 P11/D5 P12/D6 P13/D7	I/O	I/O ports P10 to P13 <ul style="list-style-type: none"> <li>Input or output in 4-bit or 1-bit units</li> <li>Used as data pins in EPROM mode</li> </ul>	<ul style="list-style-type: none"> <li>Pch: Pull-up MOS type</li> <li>Nch: Intermediate sink current type</li> </ul>	<ul style="list-style-type: none"> <li>Pull-up MOS or Nch OD output</li> <li>Output level on reset</li> </ul>	High or low (option)	Hold mode: Output off ----- Halt mode: Output retained
P20/SI0/A0 P21/SO0/A1 P22/SCK0/A2 P23/INT0/A3	I/O	I/O ports P20 to P23 <ul style="list-style-type: none"> <li>Input or output in 4-bit or 1-bit units</li> <li>P20 is also used as the serial input SI0 pin.</li> <li>P21 is also used as the serial output SO0 pin.</li> <li>P22 is also used as the serial clock SCK0 pin.</li> <li>P23 is also used as the INT0 interrupt request pin, and also as the timer 0 event counting and pulse width measurement input.</li> <li>Used as address pins in EPROM mode</li> </ul>	<ul style="list-style-type: none"> <li>Pch: CMOS type</li> <li>Nch: Intermediate sink current type</li> </ul>	CMOS or Nch OD output	H	Hold mode: Output off ----- Halt mode: Output off
P30/INT1/A4 P31/POUT0/A5 P32/POUT1/A6	I/O	I/O ports P30 to P32 <ul style="list-style-type: none"> <li>Input or output in 3-bit or 1-bit units</li> <li>P30 is also used as the INT1 interrupt request.</li> <li>P31 is also used for the square wave output from timer 0.</li> <li>P32 is also used for the square wave and PWM output from timer 1.</li> <li>P31 and P32 also support 3-state outputs.</li> <li>Used as address pins in EPROM mode</li> </ul>	<ul style="list-style-type: none"> <li>Pch: CMOS type</li> <li>Nch: Intermediate sink current type</li> </ul>	CMOS or Nch OD output	H	Hold mode: Output off ----- Halt mode: Output retained
P33/HOLD	I	Hold mode control input <ul style="list-style-type: none"> <li>Hold mode is set up by the HOLD instruction when HOLD is low.</li> <li>In hold mode, the CPU is restarted by setting HOLD to the high level.</li> <li>This pin can be used as input port P33 along with P30 to P32.</li> <li>When the P33/HOLD pin is at the low level, the CPU will not be reset by a low level on the RES pin. Therefore, applications must not set P33/HOLD low when power is first applied.</li> </ul>				
P40/INV0/A7 P41/INV00/A8 P42/INV1/A9 P43/INV10/A10	I/O	I/O ports P40 to P43 <ul style="list-style-type: none"> <li>Input or output in 4-bit or 1-bit units</li> <li>Input or output in 8-bit units when used in conjunction with P50 to P53.</li> <li>Can be used for output of 8-bit ROM data when used in conjunction with P50 to P53.</li> <li>Dedicated inverter circuit (option)</li> <li>Used as address pins in EPROM mode</li> </ul>	<ul style="list-style-type: none"> <li>Pch: Pull-up MOS type</li> <li>CMOS type when the inverter circuit option is selected</li> <li>Nch: Intermediate sink current type</li> </ul>	<ul style="list-style-type: none"> <li>Pull-up MOS or Nch OD output</li> <li>Output level on reset</li> <li>Inverter circuit</li> </ul>	<ul style="list-style-type: none"> <li>High or low (option)</li> <li>Inverter I/O is set to the output off state.</li> </ul>	Hold mode: Port output off, inverter output off ----- Halt mode: Port output retained, inverter output continues

Continued on next page.

Continued from preceding page.

Pin	I/O	Overview	Output driver type	Options	State after a reset	Standby mode operation
P50/A11 P51/A12 P52/A13 P53/INT2/TA	I/O	I/O ports P50 to P53 <ul style="list-style-type: none"> <li>Input or output in 4-bit or 1-bit units</li> <li>Input or output in 8-bit units when used in conjunction with P40 to P43.</li> <li>Can be used for output of 8-bit ROM data when used in conjunction with P40 to P43.</li> <li>P53 is also used as the INT2 interrupt request.</li> <li>Used as address pins in EPROM mode</li> </ul>	<ul style="list-style-type: none"> <li>Pch: Pull-up MOS type</li> <li>Nch: Intermediate sink current type</li> </ul>	<ul style="list-style-type: none"> <li>Pull-up MOS or Nch OD output</li> <li>Output level on reset</li> </ul>	High or low (option)	Hold mode: Output off ----- Halt mode: Output retained
P60/ML P61 P62/DT P63/PIN1	I/O	I/O ports P60 to P63 <ul style="list-style-type: none"> <li>Input or output in 4-bit or 1-bit units</li> <li>P60 is also used as the melody output ML pin.</li> <li>P62 is also used as the tone output DT pin.</li> <li>P63 is also used for the event count input to timer 1.</li> </ul>	<ul style="list-style-type: none"> <li>Pch: CMOS type</li> <li>Nch: Intermediate sink current type</li> </ul>	CMOS or Nch OD output	H	Hold mode: Output off ----- Halt mode: Output retained
PC2/ $\overline{CE}$ PC3/DASEC	I	I/O ports PC2 to PC3 <ul style="list-style-type: none"> <li>Output in 2-bit or 1-bit units</li> <li>PC3 is also used as the control <math>\overline{CE}</math> and DASEC pin in EPROM mode.</li> </ul>	<ul style="list-style-type: none"> <li>Pch: CMOS type</li> <li>Nch: Intermediate sink current type</li> </ul>	CMOS or Nch OD output	H	Hold mode: Port output off ----- Halt mode: Port output retained
PD0/INV2I PD1/INV2O PD2/INV3I PD3/INV3O	I	Dedicated input ports PD0 to PD3 Dedicated inverter circuits (option)	<ul style="list-style-type: none"> <li>When the inverter circuit option is selected.</li> <li>Pch: CMOS type</li> <li>Nch: Intermediate sink current type</li> </ul>	Inverter circuits	Normal input Inverter I/O goes to the output off state.	Hold mode: Inverter Output off ----- Halt mode: Inverter output continues
PE0 PE1	I	Dedicated input ports				Hold mode: input disabled ----- Halt mode: inputs accepted
OSC1 OSC2	I O	System clock oscillator connections When an external clock is used, leave OSC2 open and connect the clock signal to OSC1.		Ceramic oscillator or external clock selection	Option selection	Hold mode: oscillator stops ----- Halt mode: oscillator continues
$\overline{RES}/V_{PP}/\overline{OE}$	I	System reset input <ul style="list-style-type: none"> <li>When the P33/HOLD pin is at the high level, a low level input to the RES pin will initialize the CPU.</li> <li>This pin is also used as the VPP/OE pin in EPROM mode.</li> </ul>				
TEST/ EPMOD	I	CPU test pin This pin must be connected to $V_{SS}$ during normal operation. Setting this pin to +12 V switches the LC66P2316 to EPROM mode.				
$V_{DD}$ $V_{SS}$		Power supply pins				

Note: Pull-up MOS type: The output circuit includes a MOS transistor that pulls the pin up to  $V_{DD}$ .  
 CMOS output: Complementary output.  
 OD output: Open-drain output.

## User Options

### 1. Port 0, 1, 4, and 5 output level at reset option

The output levels at reset for I/O ports 0, 1, 4, and 5 in independent 4-bit groups, can be selected from the following two options.

Option	Conditions and notes
1. Output high at reset	The four bits of ports 0, 1, 4, or 5 are set in a group
2. Output low at reset	The four bits of ports 0, 1, 4, or 5 are set in a group

### 2. Oscillator circuit options

- Main clock

Option	Circuit	Conditions and notes
1. External clock		The input has Schmitt characteristics
2. Ceramic oscillator		

Note: There is no RC oscillator option.

### 3. Watchdog timer option

A runaway detection function (watchdog timer) can be selected as an option.

### 4. Port output type options

- The output type of each bit (pin) in ports P0, P1, P2, P3 (except for the P33/ $\overline{\text{HOLD}}$  pin), P4, P5, P6, and PC can be selected individually from the following two options.

Option	Circuit	Conditions and notes
1. Open-drain output		The port P2, P3, P5, and P6 inputs have Schmitt characteristics.
2. Output with built-in pull-up resistor		The port P2, P3, P5, and P6 inputs have Schmitt characteristics. The CMOS outputs (ports P2, P3, P6, and PC) and the pull-up MOS outputs (P0, P1, P4, and P5) are distinguished by the drive capacity of the p-channel transistor.



5. Inverter array circuit option

One of the following options can be selected for each of the following port sets: P40/P41, P42/P43, PD0/PD1, and PD2/PD3.

Option	Circuit	Conditions and notes
1. Normal port I/O circuit		When the open-drain output type is selected
1. Normal port I/O circuit		When the built-in pull-up resistor output type is selected
2. Inverter I/O circuit		<p>If this option is selected, The I/O circuit is disabled by the <math>\overline{DSB}</math> signal.</p> <p>Also note that the open-drain port output type option and the high level at reset option must be selected.</p>

## LC662316 Series Option Data Area and Definitions

ROM area	Bit	Option specified		Option/data relationship
3FF0H	7	P5	Output level at reset	0 = high level, 1 = low level
	6	P4		
	5	Unused		This bit must be set to 0.
	4	Oscillator option		0 = external clock, 1 = ceramic oscillator
	3	Unused		This bit must be set to 0.
	2	P1	Output level at reset	0 = low level, 1 = high level
	1	P0		
	0	Watchdog timer option		0 = none, 1 = yes (present)
3FF1H	7	P13	Output type	0 = OD, 1 = PU
	6	P12		
	5	P11		
	4	P10		
	3	P03	Output type	0 = OD, 1 = PU
	2	P02		
	1	P01		
	0	P00		
3FF2H	7	Unused		This bit must be set to 0.
	6	P32	Output type	0 = OD, 1 = PU
	5	P31		
	4	P30	Output type	0 = OD, 1 = PU
	3	P23		
	2	P22		
	1	P21		
	0	P20		
3FF3H	7	P53	Output type	0 = OD, 1 = PU
	6	P52		
	5	P51		
	4	P50		
	3	P43	Output type	0 = OD, 1 = PU
	2	P42		
	1	P41		
	0	P40		
3FF4H	7	Unused		This bit must be set to 0.
	6	Unused		
	5	Unused		
	4	Unused		
	3	P63	Output type	0 = OD, 1 = PU
	2	P62		
	1	P61		
	0	P60		
3FF5H	7	Unused		This bit must be set to 0.
	6	Unused		
	5	Unused		
	4	Unused		
	3	Unused		This bit must be set to 0.
	2	Unused		
	1	Unused		
	0	Unused		
3FF6H	7	Unused		This bit must be set to 0.
	6	Unused		
	5	Unused		
	4	Unused		
	3	Unused		This bit must be set to 0.
	2	Unused		
	1	Unused		
	0	Unused		

Continued on next page.

Continued from preceding page.

ROM area	Bit	Option specified		Option/data relationship
3FF7H	7	Unused		This bit must be set to 0.
	6			
	5			
	4			
	3	PC3	Output type	0 = OD, 1 = PU
	2	PC2		
	1	Unused		This bit must be set to 0.
	0			
3FF8H	7	ML disabled option		0 = disabled, 1 = enabled
	6	Unused		This bit must be set to 1.
	5	Unused		This bit must be set to 1.
	4	PD3	Inverter output	0 = inverter output, 1 = none
	3	PD1		
	2	Unused		This bit must be set to 1.
	1	P43	Inverter output	0 = inverter output, 1 = none
	0	P41		
3FF9H	7	Unused		This bit must be set to 0.
	6			
	5			
	4			
	3	Unused		This bit must be set to 0.
	2			
	1			
	0			
3FFAH	7	Unused		This bit must be set to 0.
	6			
	5			
	4			
	3	Unused		This bit must be set to 0.
	2			
	1			
	0			
3FFBH	7	Unused		This bit must be set to 0.
	6			
	5			
	4			
	3	Unused		This bit must be set to 0.
	2			
	1			
	0			
3FFCH	7	Unused		This bit must be set to 0.
	6			
	5			
	4			
	3	Unused		This bit must be set to 0.
	2			
	1			
	0			
3FFDH	7	Reserved. Must be set to predefined data values.		This data is generated by the assembler. If the assembler is not used, set this data to '00'.
	6			
	5			
	4			
	3			
	2			
	1			
	0			

Continued on next page.

Continued from preceding page.

ROM area	Bit	Option specified	Option/data relationship
3FFE <sub>H</sub>	7	Reserved. Must be set to predefined data values.	This data is generated by the assembler. If the assembler is not used, set this data to '00'.
	6		
	5		
	4		
	3		
	2		
	1		
	0		
3FFF <sub>H</sub>	7	Reserved. Must be set to predefined data values.	This data is generated by the assembler. If the assembler is not used, set this data to '00'.
	6		
	5		
	4		
	3		
	2		
	1		
	0		

## Usage Notes

### 1. Option specification

When using a Sanyo cross assembler with the LC66P2316, use the version called "LC66S.EXE" and specify the actual microcontroller to be evaluated with the CPU pseudo instruction in the source file. The port options must be specified in the source file. The cross assembler will create an option code list in the option specification area (locations 3FF0<sub>H</sub> to 3FFF<sub>H</sub>). It is also possible to directly set up data in the option specification area. If this is done, the options must be specified according to the option code creation table shown on the following page.

### 2. Writing the EPROM

Use a special-purpose writing conversion board (the W66EP5316D for the DIP package, and the W66EP2316Q for the QFP package) to allow the EPROM programmers listed below to be used when writing the data created by the cross assembler to the LC66P2316.

- The EPROM programmers listed below can be used.

Manufacturer	Models that can be used
Advantest	R4945, R4944A, R4943, or equivalent products
Ando	AF9704
AVAL	—
Minato Electronics	MODEL1890A

- The "27512 ( $V_{PP}$  12.5 V) Intel high-speed write" technique must be used to write the EPROM. Set the address range to location 0 to 3FFF<sub>H</sub>. The DASEC jumper must be off.

### 3. Using the data security function

The data security function sets up the microcontroller in advance so that data that was written to the microcontroller EPROM cannot be read out.

Use the following procedure to enable the LC66P2316 data security function.

- Set the write conversion board DASEC jumper to the on position.
- Write the data to the EPROM once again.

At this time, since this function will operate, the EPROM programmer will issue an error. However, this error does not indicate that there was a problem in either the programmer or the LSI.

Notes: 1. If the data at all addresses was "FF" at step 2, the data security function will not be activated.

2. The data security function will not be activated at step 2 if the "blank → program → verify" operation sequence is used.

3. Always return the jumper to the off position after the data security function has been activated.

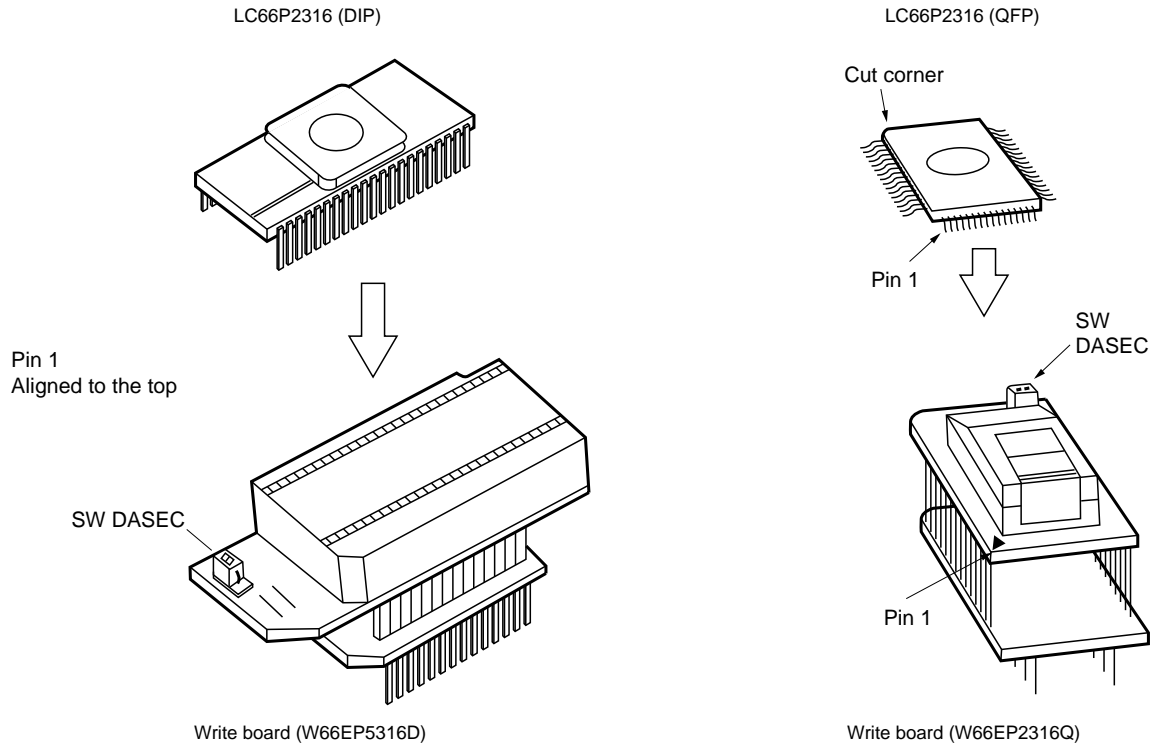

## Specifications

### Absolute Maximum Ratings at Ta = 25°C, VSS = 0 V

Parameter	Symbol	Conditions	Ratings	Unit	Note
Maximum supply voltage	V <sub>DD max</sub>	V <sub>DD</sub>	-0.3 to +7.0	V	
Input voltage	V <sub>IN1</sub>	P2, P3 (except for the P33/HOLD pin), P61, and P63	-0.3 to +12.0	V	1
	V <sub>IN2</sub>	All other inputs	-0.3 to V <sub>DD</sub> + 0.3	V	2
Output voltage	V <sub>OUT1</sub>	P2, P3 (except for the P33/HOLD pin), P61, and P63	-0.3 to +12.0	V	1
	V <sub>OUT2</sub>	All other inputs	-0.3 to V <sub>DD</sub> + 0.3	V	2
Output current per pin	I <sub>ON1</sub>	P0, P1, P2, P3 (except for the P33/HOLD pin), P4, P5, P6, PC	20	mA	3
	I <sub>ON2</sub>	P41, P43, PC3, PD1, PD3	20	mA	3
	-I <sub>OP1</sub>	P0, P1, P4, P5	2	mA	4
	-I <sub>OP2</sub>	P2, P3 (except for the P33/HOLD pin), P6, and PC	4	mA	4
Total pin current	Σ I <sub>ON1</sub>	P0, P1, P2, P3 (except for the P33/HOLD pin), PD	75	mA	3
	Σ I <sub>ON2</sub>	P4, P5, P6, PC	75	mA	3
	Σ I <sub>OP1</sub>	P0, P1, P2, P3 (except for the P33/HOLD pin), PD	25	mA	4
	Σ I <sub>OP2</sub>	P4, P5, P6, PC	25	mA	4
Allowable power dissipation	Pd max	Ta = -30 to +70°C: DIP42S (QFP48E)	600 (430)	mW	5
Operating temperature	To <sub>pr</sub>		-30 to +70	°C	
Storage temperature	T <sub>stg</sub>		-55 to +125	°C	

- Note: 1. Applies to pins with open-drain output specifications. For pins with other than open-drain output specifications, the ratings in the pin column for that pin apply.
2. For the oscillator input and output pins, levels up to the free-running oscillation level are allowed.
3. Sink current (Applies to PD when the inverter array specifications have been selected.)
4. Source current (Applies to all pins except PD for which the pull-up output specifications, the CMOS output specifications, or the inverter array specifications have been selected. Applies to P8 pins for which the inverter array specifications have been selected.) Contact your Sanyo representative for the electrical characteristics when the inverter array or buffer array options are specified.
5. We recommend the use of reflow soldering techniques to solder mount QFP packages. Please consult with your Sanyo representative for details on process conditions if the package itself is to be directly immersed in a solder dip bath (solder dip or spray techniques).

**Allowable Operating Ranges at Ta = -30 to +70°C, V<sub>SS</sub> = 0 V, V<sub>DD</sub> = 4.0 to 5.5 V, unless otherwise specified.**

Parameter	Symbol	Conditions	min	typ	max	Unit	Note
Operating supply voltage	V <sub>DD</sub>	V <sub>DD</sub>	4.0		5.5	V	
Memory retention supply voltage	V <sub>DDH</sub>	V <sub>DD</sub> : During hold mode	1.8		5.5	V	
Input high-level voltage	V <sub>IH1</sub>	P2, P3 (except for the P33/HOLD pin), P61, and P63: N-channel output transistor off	0.8 V <sub>DD</sub>		10.0	V	1
	V <sub>IH2</sub>	P33/HOLD, RES, OSC1: N-channel output transistor off	0.8 V <sub>DD</sub>		V <sub>DD</sub>	V	
	V <sub>IH3</sub>	P0, P1, P4, P5, PC, PD, PE: N-channel output transistor off	0.8 V <sub>DD</sub>		V <sub>DD</sub>	V	2
Input low-level voltage	V <sub>IL1</sub>	P2, P3 (except for the P33/HOLD pin), P6, RES, and OSC1: N-channel output transistor off	V <sub>SS</sub>		0.2 V <sub>DD</sub>	V	1
	V <sub>IL2</sub>	P33/HOLD: V <sub>DD</sub> = 1.8 to 5.5 V	V <sub>SS</sub>		0.2 V <sub>DD</sub>	V	
	V <sub>IL3</sub>	P0, P1, P4, P5, PC, PD, PE, TEST: N-channel output transistor off	V <sub>SS</sub>		0.2 V <sub>DD</sub>	V	2
Operating frequency (instruction cycle time)	f <sub>op</sub> (T <sub>cy</sub> )		0.4 (10)		4.20 (0.95)	MHz (μs)	
[External clock input conditions]							
Frequency	f <sub>ext</sub>	OSC1: Defined by Figure 1. Input the clock signal to OSC1 and leave OSC2 open. (External clock input must be selected as the oscillator circuit option.)	0.4		4.20	MHz	
Pulse width	t <sub>extH</sub> , t <sub>extL</sub>	OSC1: Defined by Figure 1. Input the clock signal to OSC1 and leave OSC2 open. (External clock input must be selected as the oscillator circuit option.)	100			ns	
Rise and fall times	t <sub>extR</sub> , t <sub>extF</sub>	OSC1: Defined by Figure 1. Input the clock signal to OSC1 and leave OSC2 open. (External clock input must be selected as the oscillator circuit option.)			30	ns	

- Note: 1. Applies to pins with open-drain specifications. However, V<sub>IH2</sub> applies to the P33/HOLD pin. When ports P2, P3, and P6 have CMOS output specifications they cannot be used as input pins.
2. PC port pins with CMOS output specifications cannot be used as input pins. Contact your Sanyo representative for the allowable operating ranges for P4 and PD when the inverter array is used.

**Electrical Characteristics at Ta = -30 to +70°C, V<sub>SS</sub> = 0 V, V<sub>DD</sub> = 4.0 to 5.5 V unless otherwise specified.**

Parameter	Symbol	Conditions	min	typ	max	Unit	Note
Input high-level current	I <sub>IH1</sub>	P2, P3 (except for the P33/HOLD pin), P61, and P63: V <sub>IN</sub> = 10.0 V, with the output Nch transistor off			5.0	μA	1
	I <sub>IH2</sub>	P0, P1, P4, P5, PC, OSC1, and P33/HOLD (Does not apply to PD, PE, PC2, PC3, P61, and P63): V <sub>IN</sub> = V <sub>DD</sub> , with the output Nch transistor off			1.0	μA	1
	I <sub>IH3</sub>	PD, PE, PC2, PC3: V <sub>IN</sub> = V <sub>DD</sub> , with the output Nch transistor off			1.0	μA	1
	I <sub>IH4</sub>	$\overline{\text{RES}}$ : V <sub>IN</sub> = V <sub>DD</sub> , operating, halt mode		10		μA	1
	I <sub>IH5</sub>	$\overline{\text{RES}}$ : V <sub>IN</sub> = V <sub>DD</sub> , hold mode			1.0	μA	1
Input low-level current	I <sub>IL1</sub>	Input ports other than PD, PE, PC2, and PC3: V <sub>IN</sub> = V <sub>SS</sub> , with the output Nch transistor off	-1.0			μA	2
	I <sub>IL2</sub>	PC2, PC3, PD, PE: V <sub>IN</sub> = V <sub>SS</sub> , with the output Nch transistor off	-1.0			μA	2
	I <sub>IL3</sub>	$\overline{\text{RES}}$ : V <sub>IN</sub> = V <sub>SS</sub>		100		μA	1
Output high-level voltage	V <sub>OH1</sub>	P2, P3 (except for the P33/HOLD pin), P6, and PC: I <sub>OH</sub> = -1 mA	V <sub>DD</sub> - 1.0			V	3
		P2, P3 (except for the P33/HOLD pin), P6, and PC: I <sub>OH</sub> = -0.1 mA	V <sub>DD</sub> - 0.5				
Value of the output pull-up resistor	R <sub>PO</sub>	P0, P1, P4, P5	30	100	150	k	4
Output low-level voltage	V <sub>OL1</sub>	P0, P1, P2, P3, P4, P5, P6, and PC (except for the P33/HOLD pin): I <sub>OL</sub> = 1.6 mA			0.4	V	
	V <sub>OL2</sub>	P0, P1, P2, P3, P4, P5, P6, and PC (except for the P33/HOLD pin): I <sub>OL</sub> = 8 mA			1.5	V	
Output off leakage current	I <sub>OFF1</sub>	P2, P3, P61, P63: V <sub>IN</sub> = V <sub>DD</sub>			5.0	μA	5
	I <sub>OFF2</sub>	Does not apply to P2, P3, P61, and P63: V <sub>IN</sub> = V <sub>DD</sub>			1.0	μA	5
[Schmitt characteristics]							
Hysteresis voltage	V <sub>HYS</sub>			0.1 V <sub>DD</sub>		V	
High-level threshold voltage	V <sub>tH</sub>	P2, P3, P5, P6, OSC1 (EXT), $\overline{\text{RES}}$		0.5 V <sub>DD</sub>	0.8 V <sub>DD</sub>	V	
Low-level threshold voltage	V <sub>tL</sub>			0.2 V <sub>DD</sub>	0.5 V <sub>DD</sub>	V	
[Ceramic oscillator]							
Oscillator frequency	f <sub>CF</sub>	OSC1, OSC2: Figure 2, 4 MHz		4.0		MHz	
Oscillator stabilization time	f <sub>CFS</sub>	Figure 3, 4 MHz			10.0	ms	
[Serial clock]							
Cycle time	Input	SCK0: With the timing of Figure 4 and the test load of Figure 5.	t <sub>CKCY</sub>	0.9			μs
	Output			2.0			T <sub>cyc</sub>
Low-level and high-level pulse widths	Input		t <sub>CKL</sub>	0.4			μs
	Output		t <sub>CKH</sub>	1.0			T <sub>cyc</sub>
Rise and fall times	Output		t <sub>CKR</sub> , t <sub>CKF</sub>			0.1	μs
[Serial input]							
Data setup time	t <sub>ICK</sub>	SIO: With the timing of Figure 4.	0.3			μs	
Data hold time	t <sub>CKI</sub>	Stipulated with respect to the rising edge (↑) of SCK0.	0.3			μs	
[Serial output]							
Output delay time	t <sub>CKO</sub>	SIO: With the timing of Figure 4 and the test load of Figure 5. Stipulated with respect to the falling edge (↓) of SCK0.			0.3	μs	

Continued on next page.

Continued from preceding page.

Parameter	Symbol	Conditions	min	typ	max	Unit	Note
[Pulse conditions]							
INT0 high and low-level	$t_{IOH}, t_{IOL}$	INT0: Figure 6, conditions under which the INT0 interrupt can be accepted, conditions under which the timer 0 event counter or pulse width measurement input can be accepted	2			Tcyc	
High and low-level pulse widths for interrupt inputs other than INT0	$t_{IIH}, t_{IIL}$	INT1, INT2: Figure 6, conditions under which the corresponding interrupt can be accepted	2			Tcyc	
PIN1 high and low-level pulse widths	$t_{PINH}, t_{PINL}$	PIN1: Figure 6, conditions under which the timer 1 event counter input can be accepted	2			Tcyc	
$\overline{RES}$ high and low-level pulse widths	$t_{RSH}, t_{RSL}$	$\overline{RES}$ : Figure 6, conditions under which reset can be applied.	3			Tcyc	
Operating current drain	$I_{DD\ OP}$	$V_{DD}$ : 4-MHz ceramic oscillator		6.0	12	mA	6
		$V_{DD}$ : 4-MHz external clock		6.0	12	mA	
Halt mode current drain	$I_{DD\ HALT}$	$V_{DD}$ : 4-MHz ceramic oscillator		4	8	mA	
		$V_{DD}$ : 4-MHz external clock		4	8	mA	
Hold mode current drain	$I_{DD\ HOLD}$	$V_{DD}$ : $V_{DD} = 1.8$ to $5.5$ V		0.01	10	$\mu A$	

- Note:
1. With the output Nch transistor off in shared I/O ports with the open-drain output specifications. These pins cannot be used as input pins if the CMOS output specifications are selected. When the port option is selected for PE.
  2. With the output Nch transistor off in shared I/O ports with the open-drain output specifications. The rating for the pull-up output specification pins is stipulated in terms of the output pull-up current IPO. These pins cannot be used as input pins if the CMOS output specifications are selected.
  3. With the output Nch transistor off for CMOS output specification pins.
  4. With the output Nch transistor off for pull-up output specification pins.
  5. With the output Nch transistor off for open-drain output specification pins.
  6. Reset state

### Tone (DTMF) Output Characteristics

#### DC Characteristics at $T_a = -30$ to $+70^\circ C$ , $V_{SS} = 0$ V

Parameter	Symbol	Conditions	min	typ	max	Unit
Tone output voltage (p-p)	$V_{T1}$	DT: Dual tones, $V_{DD} = 4.0$ to $5.5$ V	0.9	1.3	2.0	V
Row/column tone output voltage ratio	$D_{BCR1}$	DT: Dual tones, $V_{DD} = 4.0$ to $5.5$ V	1.0	2.0	3.0	dB
Tone distortion	THD1	DT: Single tone, $V_{DD} = 4.0$ to $5.5$ V		2	7	%

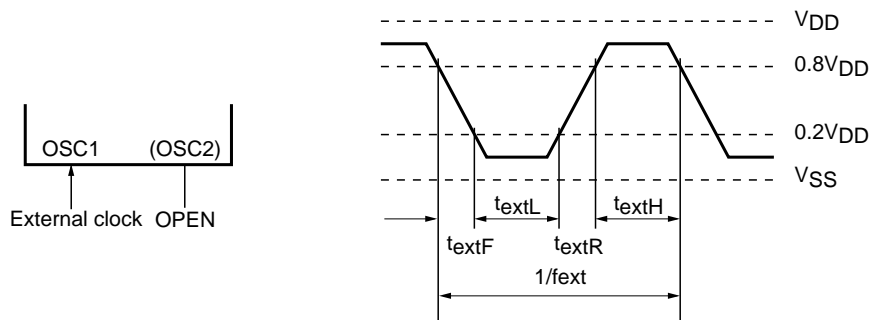

Figure 1 External Clock Input Waveform



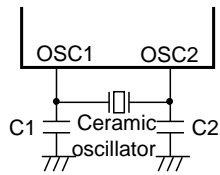

Figure 2 Ceramic Oscillator Circuit

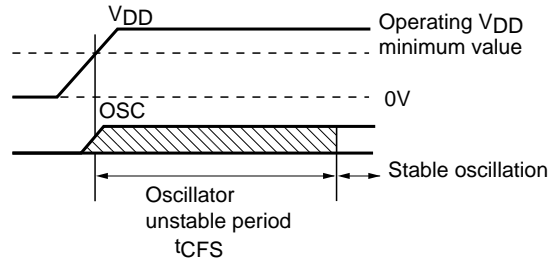

Figure 3 Oscillator Stabilization Period

Table 1 Guaranteed Ceramic Oscillator Constants External capacitor type

External capacitor type		Built-in capacitor type
4 MHz (Murata Mfg. Co., Ltd.) CSA4.00MG	C1 = 33 pF ± 10%	4 MHz (Murata Mfg. Co., Ltd.) CST4.00MG
	C2 = 33 pF ± 10%	
4 MHz (Kyocera Corporation) KBR4.0MS	C1 = 33 pF ± 10%	4 MHz (Kyocera Corporation) KBR4.0MES
	C2 = 33 pF ± 10%	

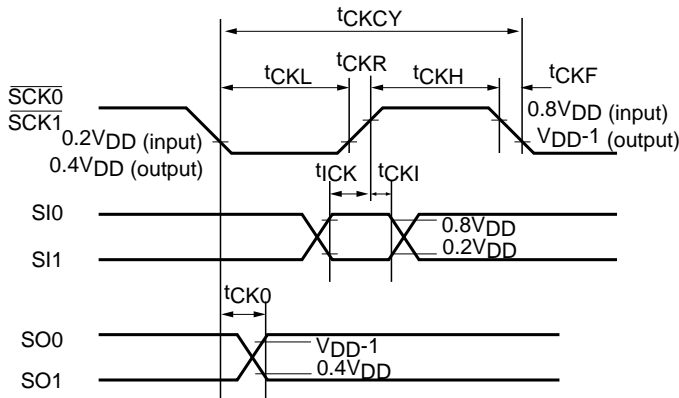

Figure 4 Serial I/O Timing

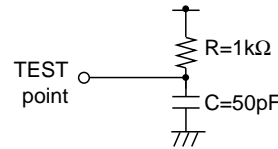

Figure 5 Timing Load

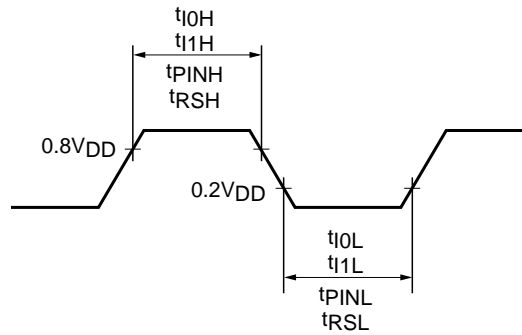

Figure 6 Input Timing for the INT0, INT1, INT2, PIN1, and RES pins

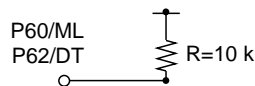

Figure 7 Tone Output Pin Load

## Preconditions for mounting one-time programmable microprocessors

### Usage Notes

Due to inherent structural considerations, it is impossible to fully test one-time programmable microprocessors before the PROM has been programmed, i.e. before shipment from the factory. We recommend that users screen products whose PROM has been written according to the following procedure to improve the reliability of these products.

- Due to the nature of the product, it is not possible to test write operations to all bits in one-time programmable microprocessors whose PROM has not been written. Therefore it may be impossible to guarantee a 100% yield on writing to these products. Please understand that no such guarantee may be made.
- Storage of products in the moisture-proof packed (unopened) state
- Store products in moisture-proof packages in an environment in which the temperature is no higher than 30°C and the relative humidity is no higher than 70%.
- Storage of products after opening the moisture-proof packaging
- After opening products that were packed in moisture-proof packaging, mount (solder) those products as soon as possible. Store products for no more than 96 hours after opening the moisture-proof packaging in an environment in which the temperature is no higher than 30°C and the relative humidity is no higher than 70%.

a. Preconditions for mounting products that were programmed by the user

b. Preconditions for mounting products that were programmed by Sanyo

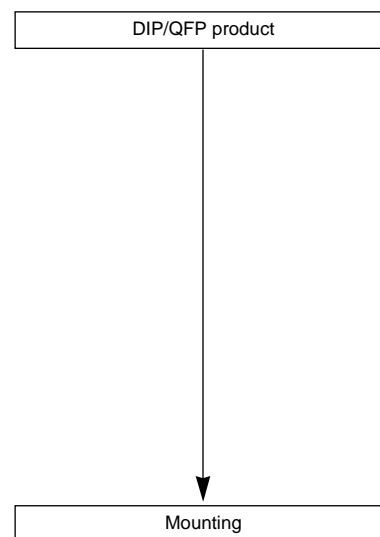
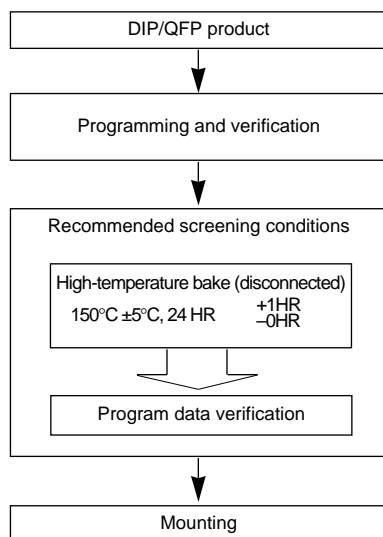

### Sanyo ROM writing service

Sanyo provides a for-fee ROM writing service that includes writing the one-time programmable ROM, printing, screening, and read-out verification. Contact your Sanyo sales representative for details.

**LC66XXXX Series Instruction Table (by function)**

## Abbreviations:

AC:	Accumulator
E:	E register
CF:	Carry flag
ZF:	Zero flag
HL:	Data pointer DPH, DPL
XY:	Data pointer DPX, DPY
M:	Data memory
M (HL):	Data memory pointed to by the DPH, DPL data pointer
M (XY):	Data memory pointed to by the DPX, DPY auxiliary data pointer
M2 (HL):	Two words of data memory (starting on an even address) pointed to by the DPH, DPL data pointer
SP:	Stack pointer
M2 (SP):	Two words of data memory pointed to by the stack pointer
M4 (SP):	Four words of data memory pointed to by the stack pointer
in:	n bits of immediate data
t2:	Bit specification

t2	11	10	01	00
Bit	$2^3$	$2^2$	$2^1$	$2^0$

PCh:	Bits 8 to 11 in the PC
PCm:	Bits 4 to 7 in the PC
PCl:	Bits 0 to 3 in the PC
Fn:	User flag, n = 0 to 15
TIMER0:	Timer 0
TIMER1:	Timer 1
SIO:	Serial register
P:	Port
P (i4):	Port indicated by 4 bits of immediate data
INT:	Interrupt enable flag
( ), [ ]:	Indicates the contents of a location
←:	Transfer direction, result
∨:	Exclusive or
∧:	Logical and
∨:	Logical or
+:	Addition
-:	Subtraction
—:	Taking the one's complement

Mnemonic	Instruction code		Number of bytes	Number of cycles	Operation	Description	Affected status bits	Note	
	D <sub>7</sub> D <sub>6</sub> D <sub>5</sub> D <sub>4</sub>	D <sub>3</sub> D <sub>2</sub> D <sub>1</sub> D <sub>0</sub>							
[Accumulator manipulation instructions]									
CLA	Clear AC	1 0 0 0	0 0 0 0	1	1	AC ← 0 (Equivalent to LAI 0.)	Clear AC to 0.	ZF	Has a vertical skip function.
DAA	Decimal adjust AC in addition	1 1 0 0 0 0 1 0	1 1 1 1 0 1 1 0	2	2	AC ← (AC) + 6 (Equivalent to ADI 6.)	Add six to AC.	ZF	
DAS	Decimal adjust AC in subtraction	1 1 0 0 0 0 1 0	1 1 1 1 1 0 1 0	2	2	AC ← (AC) + 10 (Equivalent to ADI 0AH.)	Add 10 to AC.	ZF	
CLC	Clear CF	0 0 0 1	1 1 1 0	1	1	CF ← 0	Clear CF to 0.	CF	
STC	Set CF	0 0 0 1	1 1 1 1	1	1	CF ← 1	Set CF to 1.	CF	
CMA	Complement AC	0 0 0 1	1 0 0 0	1	1	AC ← $\overline{(AC)}$	Take the one's complement of AC.	ZF	
IA	Increment AC	0 0 0 1	0 1 0 0	1	1	AC ← (AC) + 1	Increment AC.	ZF, CF	
DA	Decrement AC	0 0 1 0	0 1 0 0	1	1	AC ← (AC) - 1	Decrement AC.	ZF, CF	
RAR	Rotate AC right through CF	0 0 0 1	0 0 0 0	1	1	AC <sub>3</sub> ← (CF), AC <sub>n</sub> ← (AC <sub>n</sub> + 1), CF ← (AC <sub>0</sub> )	Shift AC (including CF) right.	CF	
RAL	Rotate AC left through CF	0 0 0 0	0 0 0 1	1	1	AC <sub>0</sub> ← (CF), AC <sub>n</sub> + 1 ← (AC <sub>n</sub> ), CF ← (AC <sub>3</sub> )	Shift AC (including CF) left.	CF, ZF	
TAE	Transfer AC to E	0 1 0 0	0 1 0 1	1	1	E ← (AC)	Transfer the contents of AC to E.		
TEA	Transfer E to AC	0 1 0 0	0 1 1 0	1	1	AC ← (E)	Transfer the contents of E to AC.	ZF	
XAE	Exchange AC with E	0 1 0 0	0 1 0 0	1	1	(AC) ↔ (E)	Exchange the contents of AC and E.		
[Memory manipulation instructions]									
IM	Increment M	0 0 0 1	0 0 1 0	1	1	M (HL) ← [M (HL)] + 1	Increment M (HL).	ZF, CF	
DM	Decrement M	0 0 1 0	0 0 1 0	1	1	M (HL) ← [M (HL)] - 1	Decrement M (HL).	ZF, CF	
IMDR i8	Increment M direct	1 1 0 0 I <sub>7</sub> I <sub>6</sub> I <sub>5</sub> I <sub>4</sub>	0 1 1 1 I <sub>3</sub> I <sub>2</sub> I <sub>1</sub> I <sub>0</sub>	2	2	M (i8) ← [M (i8)] + 1	Increment M (i8).	ZF, CF	
DMDR i8	Decrement M direct	1 1 0 0 I <sub>7</sub> I <sub>6</sub> I <sub>5</sub> I <sub>4</sub>	0 0 1 1 I <sub>3</sub> I <sub>2</sub> I <sub>1</sub> I <sub>0</sub>	2	2	M (i8) ← [M (i8)] - 1	Decrement M (i8).	ZF, CF	
SMB t2	Set M data bit	0 0 0 0	1 1 t <sub>1</sub> t <sub>0</sub>	1	1	[M (HL), t2] ← 1	Set the bit in M (HL) specified by t0 and t1 to 1.		
RMB t2	Reset M data bit	0 0 1 0	1 1 t <sub>1</sub> t <sub>0</sub>	1	1	[M (HL), t2] ← 0	Clear the bit in M (HL) specified by t0 and t1 to 0.	ZF	
[Arithmetic, logic and comparison instructions]									
AD	Add M to AC	0 0 0 0	0 1 1 0	1	1	AC ← (AC) + [M (HL)]	Add the contents of AC and M (HL) as two's complement values and store the result in AC.	ZF, CF	
ADDR i8	Add M direct to AC	1 1 0 0 I <sub>7</sub> I <sub>6</sub> I <sub>5</sub> I <sub>4</sub>	1 0 0 1 I <sub>3</sub> I <sub>2</sub> I <sub>1</sub> I <sub>0</sub>	2	2	AC ← (AC) + [M (i8)]	Add the contents of AC and M (i8) as two's complement values and store the result in AC.	ZF, CF	
ADC	Add M to AC with CF	0 0 0 0	0 0 1 0	1	1	AC ← (AC) + [M (HL)] + (CF)	Add the contents of AC, M (HL) and C as two's complement values and store the result in AC.	ZF, CF	
ADI i4	Add immediate data to AC	1 1 0 0 0 0 1 0	1 1 1 1 I <sub>3</sub> I <sub>2</sub> I <sub>1</sub> I <sub>0</sub>	2	2	AC ← (AC) + I <sub>3</sub> , I <sub>2</sub> , I <sub>1</sub> , I <sub>0</sub>	Add the contents of AC and the immediate data as two's complement values and store the result in AC.	ZF	
SUBC	Subtract AC from M with CF	0 0 0 1	0 1 1 1	1	1	AC ← [M (HL)] - (AC) - (CF)	Subtract the contents of AC and CF from M (HL) as two's complement values and store the result in AC.	ZF, CF	CF will be zero if there was a borrow and one otherwise.
ANDA	And M with AC then store AC	0 0 0 0	0 1 1 1	1	1	AC ← (AC) ∧ [M (HL)]	Take the logical and of AC and M (HL) and store the result in AC.	ZF	
ORA	Or M with AC then store AC	0 0 0 0	0 1 0 1	1	1	AC ← (AC) ∨ [M (HL)]	Take the logical or of AC and M (HL) and store the result in AC.	ZF	

Continued on next page.

Continued from preceding page.

Mnemonic	Instruction code		Number of bytes	Number of cycles	Operation	Description	Affected status bits	Note													
	D <sub>7</sub> D <sub>6</sub> D <sub>5</sub> D <sub>4</sub>	D <sub>3</sub> D <sub>2</sub> D <sub>1</sub> D <sub>0</sub>																			
[Arithmetic, logic and comparison instructions]																					
EXL	Exclusive or M with AC then store AC	0 0 0 1	0 1 0 1	1	1	$AC \leftarrow (AC) \nabla [M (HL)]$	Take the logical exclusive or of AC and M (HL) and store the result in AC.	ZF													
ANDM	And M with AC then store M	0 0 0 0	0 0 1 1	1	1	$M (HL) \leftarrow (AC) \wedge [M (HL)]$	Take the logical and of AC and M (HL) and store the result in M (HL).	ZF													
ORM	Or M with AC then store M	0 0 0 0	0 1 0 0	1	1	$M (HL) \leftarrow (AC) \vee [M (HL)]$	Take the logical or of AC and M (HL) and store the result in M (HL).	ZF													
CM	Compare AC with M	0 0 0 1	0 1 1 0	1	1	$\overline{[M (HL)]} + (AC) + 1$	Compare the contents of AC and M (HL) and set or clear CF and ZF according to the result. <table border="1" style="margin-left: auto; margin-right: auto;"> <tr> <td>Magnitude comparison</td> <td>CF</td> <td>ZF</td> </tr> <tr> <td><math>[M (HL)] &gt; (AC)</math></td> <td>0</td> <td>0</td> </tr> <tr> <td><math>[M (HL)] = (AC)</math></td> <td>1</td> <td>1</td> </tr> <tr> <td><math>[M (HL)] &lt; (AC)</math></td> <td>1</td> <td>0</td> </tr> </table>	Magnitude comparison	CF	ZF	$[M (HL)] > (AC)$	0	0	$[M (HL)] = (AC)$	1	1	$[M (HL)] < (AC)$	1	0	ZF, CF	
Magnitude comparison	CF	ZF																			
$[M (HL)] > (AC)$	0	0																			
$[M (HL)] = (AC)$	1	1																			
$[M (HL)] < (AC)$	1	0																			
CI i4	Compare AC with immediate data	1 1 0 0 1 0 1 0	1 1 1 1 i <sub>3</sub> i <sub>2</sub> i <sub>1</sub> i <sub>0</sub>	2	2	$\overline{i_3 i_2 i_1 i_0} + (AC) + 1$	Compare the contents of AC and the immediate data i <sub>3</sub> i <sub>2</sub> i <sub>1</sub> i <sub>0</sub> and set or clear CF and ZF according to the result. <table border="1" style="margin-left: auto; margin-right: auto;"> <tr> <td>Magnitude comparison</td> <td>CF</td> <td>ZF</td> </tr> <tr> <td>i<sub>3</sub> i<sub>2</sub> i<sub>1</sub> i<sub>0</sub> &gt; AC</td> <td>0</td> <td>0</td> </tr> <tr> <td>i<sub>3</sub> i<sub>2</sub> i<sub>1</sub> i<sub>0</sub> = AC</td> <td>1</td> <td>1</td> </tr> <tr> <td>i<sub>3</sub> i<sub>2</sub> i<sub>1</sub> i<sub>0</sub> &lt; AC</td> <td>1</td> <td>0</td> </tr> </table>	Magnitude comparison	CF	ZF	i <sub>3</sub> i <sub>2</sub> i <sub>1</sub> i <sub>0</sub> > AC	0	0	i <sub>3</sub> i <sub>2</sub> i <sub>1</sub> i <sub>0</sub> = AC	1	1	i <sub>3</sub> i <sub>2</sub> i <sub>1</sub> i <sub>0</sub> < AC	1	0	ZF, CF	
Magnitude comparison	CF	ZF																			
i <sub>3</sub> i <sub>2</sub> i <sub>1</sub> i <sub>0</sub> > AC	0	0																			
i <sub>3</sub> i <sub>2</sub> i <sub>1</sub> i <sub>0</sub> = AC	1	1																			
i <sub>3</sub> i <sub>2</sub> i <sub>1</sub> i <sub>0</sub> < AC	1	0																			
CLI i4	Compare DP <sub>L</sub> with immediate data	1 1 0 0 1 0 1 1	1 1 1 1 i <sub>3</sub> i <sub>2</sub> i <sub>1</sub> i <sub>0</sub>	2	2	ZF ← 1 if (DP <sub>L</sub> ) = i <sub>3</sub> i <sub>2</sub> i <sub>1</sub> i <sub>0</sub> ZF ← 0 if (DP <sub>L</sub> ) ≠ i <sub>3</sub> i <sub>2</sub> i <sub>1</sub> i <sub>0</sub>	Compare the contents of DP <sub>L</sub> with the immediate data. Set ZF if identical and clear ZF if not.	ZF													
CMB t2	Compare AC bit with M data bit	1 1 0 0 1 1 0 1	1 1 1 1 0 0 t <sub>1</sub> t <sub>0</sub>	2	2	ZF ← 1 if (AC, t <sub>2</sub> ) = [M (HL), t <sub>2</sub> ] ZF ← 0 if (AC, t <sub>2</sub> ) ≠ [M (HL), t <sub>2</sub> ]	Compare the corresponding bits specified by t <sub>0</sub> and t <sub>1</sub> in AC and M (HL). Set ZF if identical and clear ZF if not.	ZF													
[Load and store instructions]																					
LAE	Load AC and E from M2 (HL)	0 1 0 1	1 1 0 0	1	1	AC ← M (HL), E ← M (HL + 1)	Load the contents of M2 (HL) into AC, E.														
LAI i4	Load AC with immediate data	1 0 0 0	i <sub>3</sub> i <sub>2</sub> i <sub>1</sub> i <sub>0</sub>	1	1	AC ← i <sub>3</sub> i <sub>2</sub> i <sub>1</sub> i <sub>0</sub>	Load the immediate data into AC.	ZF	Has a vertical skip function												
LADR i8	Load AC from M direct	1 1 0 0 i <sub>7</sub> i <sub>6</sub> i <sub>5</sub> i <sub>4</sub>	0 0 0 1 i <sub>3</sub> i <sub>2</sub> i <sub>1</sub> i <sub>0</sub>	2	2	AC ← [M (i8)]	Load the contents of M (i8) into AC.	ZF													
S	Store AC to M	0 1 0 0	0 1 1 1	1	1	M (HL) ← (AC)	Store the contents of AC into M (HL).														
SAE	Store AC and E to M2 (HL)	0 1 0 1	1 1 1 0	1	1	M (HL) ← (AC) M (HL + 1) ← (E)	Store the contents of AC, E into M2 (HL).														
LA reg	Load AC from M (reg)	0 1 0 0	1 0 t <sub>0</sub> 0	1	1	AC ← [M (reg)]	Load the contents of M (reg) into AC. The reg is either HL or XY depending on t <sub>0</sub> . <table border="1" style="margin-left: auto; margin-right: auto;"> <tr> <td>reg</td> <td>T<sub>0</sub></td> </tr> <tr> <td>HL</td> <td>0</td> </tr> <tr> <td>XY</td> <td>1</td> </tr> </table>	reg	T <sub>0</sub>	HL	0	XY	1	ZF							
reg	T <sub>0</sub>																				
HL	0																				
XY	1																				

Continued on next page.

Continued from preceding page.

Mnemonic	Instruction code		Number of bytes	Number of cycles	Operation	Description	Affected status bits	Note							
	D <sub>7</sub> D <sub>6</sub> D <sub>5</sub> D <sub>4</sub>	D <sub>3</sub> D <sub>2</sub> D <sub>1</sub> D <sub>0</sub>													
[Load and store instructions]															
LA reg, I	Load AC from M (reg) then increment reg	0 1 0 0	1 0 t <sub>0</sub> 1	1	2	AC ← [M (reg)] DP <sub>L</sub> ← (DP <sub>L</sub> ) + 1 or DP <sub>Y</sub> ← (DP <sub>Y</sub> ) + 1	Load the contents of M (reg) into AC. (The reg is either HL or XY.) Then increment the contents of either DP <sub>L</sub> or DP <sub>Y</sub> . The relationship between t <sub>0</sub> and reg is the same as that for the LA reg instruction.	ZF	ZF is set according to the result of incrementing DP <sub>L</sub> or DP <sub>Y</sub> .						
LA reg, D	Load AC from M (reg) then decrement reg	0 1 0 1	1 0 t <sub>0</sub> 1	1	2	AC ← [M (reg)] DP <sub>L</sub> ← (DP <sub>L</sub> ) - 1 or DP <sub>Y</sub> ← (DP <sub>Y</sub> ) - 1	Load the contents of M (reg) into AC. (The reg is either HL or XY.) Then decrement the contents of either DP <sub>L</sub> or DP <sub>Y</sub> . The relationship between t <sub>0</sub> and reg is the same as that for the LA reg instruction.	ZF	ZF is set according to the result of decrementing DP <sub>L</sub> or DP <sub>Y</sub> .						
XA reg	Exchange AC with M (reg)	0 1 0 0	1 1 t <sub>0</sub> 0	1	1	(AC) ↔ [M (reg)]	Exchange the contents of M (reg) and AC. The reg is either HL or XY depending on t <sub>0</sub> .								
							<table border="1"> <tr> <td>reg</td> <td>T<sub>0</sub></td> </tr> <tr> <td>HL</td> <td>0</td> </tr> <tr> <td>XY</td> <td>1</td> </tr> </table>	reg	T <sub>0</sub>	HL	0	XY	1		
reg	T <sub>0</sub>														
HL	0														
XY	1														
XA reg, I	Exchange AC with M (reg) then increment reg	0 1 0 0	1 1 t <sub>0</sub> 1	1	2	(AC) ↔ [M (reg)] DP <sub>L</sub> ← (DP <sub>L</sub> ) + 1 or DP <sub>Y</sub> ← (DP <sub>Y</sub> ) + 1	Exchange the contents of M (reg) and AC. (The reg is either HL or XY.) Then increment the contents of either DP <sub>L</sub> or DP <sub>Y</sub> . The relationship between t <sub>0</sub> and reg is the same as that for the XA reg instruction.	ZF	ZF is set according to the result of incrementing DP <sub>L</sub> or DP <sub>Y</sub> .						
XA reg, D	Exchange AC with M (reg) then decrement reg	0 1 0 1	1 1 t <sub>0</sub> 1	1	2	(AC) ↔ [M (reg)] DP <sub>L</sub> ← (DP <sub>L</sub> ) - 1 or DP <sub>Y</sub> ← (DP <sub>Y</sub> ) - 1	Exchange the contents of M (reg) and AC. (The reg is either HL or XY.) Then decrement the contents of either DP <sub>L</sub> or DP <sub>Y</sub> . The relationship between t <sub>0</sub> and reg is the same as that for the XA reg instruction.	ZF	ZF is set according to the result of decrementing DP <sub>L</sub> or DP <sub>Y</sub> .						
XADR i8	Exchange AC with M direct	1 1 0 0 l <sub>7</sub> l <sub>6</sub> l <sub>5</sub> l <sub>4</sub>	1 0 0 0 l <sub>3</sub> l <sub>2</sub> l <sub>1</sub> l <sub>0</sub>	2	2	(AC) ↔ [M (i8)]	Exchange the contents of AC and M (i8).								
LEAI i8	Load E & AC with immediate data	1 1 0 0 l <sub>7</sub> l <sub>6</sub> l <sub>5</sub> l <sub>4</sub>	0 1 1 0 l <sub>3</sub> l <sub>2</sub> l <sub>1</sub> l <sub>0</sub>	2	2	E ← l <sub>7</sub> l <sub>6</sub> l <sub>5</sub> l <sub>4</sub> AC ← l <sub>3</sub> l <sub>2</sub> l <sub>1</sub> l <sub>0</sub>	Load the immediate data i8 into E, AC.								
RTBL	Read table data from program ROM	0 1 0 1	1 0 1 0	1	2	E, AC ← [ROM (PCh, E, AC)]	Load into E, AC the ROM data at the location determined by replacing the lower 8 bits of the PC with E, AC.								
RTBLP	Read table data from program ROM then output to P4, 5	0 1 0 1	1 0 0 0	1	2	Port 4, 5 ← [ROM (PCh, E, AC)]	Output from ports 4 and 5 the ROM data at the location determined by replacing the lower 8 bits of the PC with E, AC.								
[Data pointer manipulation instructions]															
LDZ i4	Load DP <sub>H</sub> with zero and DP <sub>L</sub> with immediate data respectively	0 1 1 0	l <sub>3</sub> l <sub>2</sub> l <sub>1</sub> l <sub>0</sub>	1	1	DP <sub>H</sub> ← 0 DPL ← l <sub>3</sub> l <sub>2</sub> l <sub>1</sub> l <sub>0</sub>	Load zero into DP <sub>H</sub> and the immediate data i4 into DP <sub>L</sub> .								
LHI i4	Load DP <sub>H</sub> with immediate data	1 1 0 0 0 0 0 0	l <sub>3</sub> l <sub>2</sub> l <sub>1</sub> l <sub>0</sub>	2	2	DP <sub>H</sub> ← l <sub>3</sub> l <sub>2</sub> l <sub>1</sub> l <sub>0</sub>	Load the immediate data i4 into DP <sub>H</sub> .								
LLI i4	Load DP <sub>L</sub> with immediate data	1 1 0 0 0 0 0 1	l <sub>3</sub> l <sub>2</sub> l <sub>1</sub> l <sub>0</sub>	2	2	DP <sub>L</sub> ← l <sub>3</sub> l <sub>2</sub> l <sub>1</sub> l <sub>0</sub>	Load the immediate data i4 into DP <sub>L</sub> .								
LHLI i8	Load DP <sub>H</sub> , DP <sub>L</sub> with immediate data	1 1 0 0 l <sub>7</sub> l <sub>6</sub> l <sub>5</sub> l <sub>4</sub>	0 0 0 0 l <sub>3</sub> l <sub>2</sub> l <sub>1</sub> l <sub>0</sub>	2	2	DP <sub>H</sub> ← l <sub>7</sub> l <sub>6</sub> l <sub>5</sub> l <sub>4</sub> DP <sub>L</sub> ← l <sub>3</sub> l <sub>2</sub> l <sub>1</sub> l <sub>0</sub>	Load the immediate data into DL <sub>H</sub> , DP <sub>L</sub> .								
LXYI i8	Load DP <sub>X</sub> , DP <sub>Y</sub> with immediate data	1 1 0 0 l <sub>7</sub> l <sub>6</sub> l <sub>5</sub> l <sub>4</sub>	0 0 0 0 l <sub>3</sub> l <sub>2</sub> l <sub>1</sub> l <sub>0</sub>	2	2	DP <sub>X</sub> ← l <sub>7</sub> l <sub>6</sub> l <sub>5</sub> l <sub>4</sub> DP <sub>Y</sub> ← l <sub>3</sub> l <sub>2</sub> l <sub>1</sub> l <sub>0</sub>	Load the immediate data into DL <sub>X</sub> , DP <sub>Y</sub> .								

Continued on next page.

Continued from preceding page.

Mnemonic	Instruction code		Number of bytes	Number of cycles	Operation	Description	Affected status bits	Note
	D <sub>7</sub> D <sub>6</sub> D <sub>5</sub> D <sub>4</sub>	D <sub>3</sub> D <sub>2</sub> D <sub>1</sub> D <sub>0</sub>						
[Data pointer manipulation instructions]								
IL	Increment DP <sub>L</sub>	0 0 0 1	0 0 0 1	1	1	DP <sub>L</sub> ← (DP <sub>L</sub> ) + 1	Increment the contents of DP <sub>L</sub> .	ZF
DL	Decrement DP <sub>L</sub>	0 0 1 0	0 0 0 1	1	1	DP <sub>L</sub> ← (DP <sub>L</sub> ) - 1	Decrement the contents of DP <sub>L</sub> .	ZF
IY	Increment DP <sub>Y</sub>	0 0 0 1	0 0 1 1	1	1	DP <sub>Y</sub> ← (DP <sub>Y</sub> ) + 1	Increment the contents of DP <sub>Y</sub> .	ZF
DY	Decrement DP <sub>Y</sub>	0 0 1 0	0 0 1 1	1	1	DP <sub>Y</sub> ← (DP <sub>Y</sub> ) - 1	Decrement the contents of DP <sub>Y</sub> .	ZF
TAH	Transfer AC to DP <sub>H</sub>	1 1 0 0 1 1 1 1	1 1 1 1 0 0 0 0	2	2	DP <sub>H</sub> ← (AC)	Transfer the contents of AC to DP <sub>H</sub> .	
THA	Transfer DP <sub>H</sub> to AC	1 1 0 0 1 1 1 0	1 1 1 1 0 0 0 0	2	2	AC ← (DP <sub>H</sub> )	Transfer the contents of DP <sub>H</sub> to AC.	ZF
XAH	Exchange AC with DP <sub>H</sub>	0 1 0 0	0 0 0 0	1	1	(AC) ↔ (DP <sub>H</sub> )	Exchange the contents of AC and DP <sub>H</sub> .	
TAL	Transfer AC to DP <sub>L</sub>	1 1 0 0 1 1 1 1	1 1 1 1 0 0 0 1	2	2	DP <sub>L</sub> ← (AC)	Transfer the contents of AC to DP <sub>L</sub> .	
TLA	Transfer DP <sub>L</sub> to AC	1 1 0 0 1 1 1 0	1 1 1 1 0 0 0 1	2	2	AC ← (DP <sub>L</sub> )	Transfer the contents of DP <sub>L</sub> to AC.	ZF
XAL	Exchange AC with DP <sub>L</sub>	0 1 0 0	0 0 0 1	1	1	(AC) ↔ (DP <sub>L</sub> )	Exchange the contents of AC and DP <sub>L</sub> .	
TAX	Transfer AC to DP <sub>X</sub>	1 1 0 0 1 1 1 1	1 1 1 1 0 0 1 0	2	2	DP <sub>X</sub> ← (AC)	Transfer the contents of AC to DP <sub>X</sub> .	
TXA	Transfer DP <sub>X</sub> to AC	1 1 0 0 1 1 1 0	1 1 1 1 0 0 1 0	2	2	AC ← (DP <sub>X</sub> )	Transfer the contents of DP <sub>X</sub> to AC.	ZF
XAX	Exchange AC with DP <sub>X</sub>	0 1 0 0	0 0 1 0	1	1	(AC) ↔ (DP <sub>X</sub> )	Exchange the contents of AC and DP <sub>X</sub> .	
TAY	Transfer AC to DP <sub>Y</sub>	1 1 0 0 1 1 1 1	1 1 1 1 0 0 1 1	2	2	DP <sub>Y</sub> ← (AC)	Transfer the contents of AC to DP <sub>Y</sub> .	
TYA	Transfer DP <sub>Y</sub> to AC	1 1 0 0 1 1 1 0	1 1 1 1 0 0 1 1	2	2	AC ← (DP <sub>Y</sub> )	Transfer the contents of DP <sub>Y</sub> to AC.	ZF
XAY	Exchange AC with DP <sub>Y</sub>	0 1 0 0	0 0 1 1	1	1	(AC) ↔ (DP <sub>Y</sub> )	Exchange the contents of AC and DP <sub>Y</sub> .	
[Flag manipulation instructions]								
SFB n <sub>4</sub>	Set flag bit	0 1 1 1	n <sub>3</sub> n <sub>2</sub> n <sub>1</sub> n <sub>0</sub>	1	1	F <sub>n</sub> ← 1	Set the flag specified by n <sub>4</sub> to 1.	
RFB n <sub>4</sub>	Reset flag bit	0 0 1 1	n <sub>3</sub> n <sub>2</sub> n <sub>1</sub> n <sub>0</sub>	1	1	F <sub>n</sub> ← 0	Reset the flag specified by n <sub>4</sub> to 0.	ZF
[Jump and subroutine instructions]								
JMP addr	Jump in the current bank	1 1 1 0 P <sub>7</sub> P <sub>6</sub> P <sub>5</sub> P <sub>4</sub>	P <sub>11</sub> P <sub>10</sub> P <sub>9</sub> P <sub>8</sub> P <sub>3</sub> P <sub>2</sub> P <sub>1</sub> P <sub>0</sub>	2	2	PC13, 12 ← PC13, 12 PC11 to 0 ← P <sub>11</sub> to P <sub>8</sub>	Jump to the location in the same bank specified by the immediate data P12.	This becomes PC12 + (PC12) immediately following a BANK instruction.
JPEA	Jump to the address stored at E and AC in the current page	0 0 1 0	0 1 1 1	1	1	PC13 to 8 ← PC13 to 8, PC7 to 4 ← (E), PC3 to 0 ← (AC)	Jump to the location determined by replacing the lower 8 bits of the PC by E, AC.	
CAL addr	Call subroutine	0 1 0 1 P <sub>7</sub> P <sub>6</sub> P <sub>5</sub> P <sub>4</sub>	0 P <sub>10</sub> P <sub>9</sub> P <sub>8</sub> P <sub>3</sub> P <sub>2</sub> P <sub>1</sub> P <sub>0</sub>	2	2	PC13 to 11 ← 0, PC10 to 0 ← P <sub>10</sub> to P <sub>0</sub> , M4 (SP) ← (CF, ZF, PC13 to 0), SP ← (SP)-4	Call a subroutine.	
CZP addr	Call subroutine in the zero page	1 0 1 0	P <sub>3</sub> P <sub>2</sub> P <sub>1</sub> P <sub>0</sub>	1	2	PC13 to 6, PC10 ← 0, PC5 to 2 ← P <sub>3</sub> to P <sub>0</sub> , M4 (SP) ← (CF, ZF, PC12 to 0), SP ← SP-4	Call a subroutine on page 0 in bank 0.	
BANK	Change bank	0 0 0 1	1 0 1 1	1	1		Change the memory bank and register bank.	

Continued on next page.

Continued from preceding page.

Mnemonic	Instruction code		Number of bytes	Number of cycles	Operation	Description	Affected status bits	Note																
	D <sub>7</sub> D <sub>6</sub> D <sub>5</sub> D <sub>4</sub>	D <sub>3</sub> D <sub>2</sub> D <sub>1</sub> D <sub>0</sub>																						
[Jump and subroutine instructions]																								
PUSH reg	Push reg on M2 (SP)	1 1 0 0 1 1 1 1	1 1 1 1 1 i <sub>1</sub> i <sub>0</sub> 0	2	2	M2 (SP) ← (reg) SP ← (SP) - 2	Store the contents of reg in M2 (SP). Subtract 2 from SP after the store. <table border="1" style="margin-left: 20px;"> <tr> <td>reg</td> <td>i<sub>1</sub></td> <td>i<sub>0</sub></td> </tr> <tr> <td>HL</td> <td>0</td> <td>0</td> </tr> <tr> <td>XY</td> <td>0</td> <td>1</td> </tr> <tr> <td>AE</td> <td>1</td> <td>0</td> </tr> <tr> <td>Illegal value</td> <td>1</td> <td>1</td> </tr> </table>	reg	i <sub>1</sub>	i <sub>0</sub>	HL	0	0	XY	0	1	AE	1	0	Illegal value	1	1		
reg	i <sub>1</sub>	i <sub>0</sub>																						
HL	0	0																						
XY	0	1																						
AE	1	0																						
Illegal value	1	1																						
POP reg	Pop reg off M2 (SP)	1 1 0 0 1 1 1 0	1 1 1 1 1 i <sub>1</sub> i <sub>0</sub> 0	2	2	SP ← (SP) + 2 reg ← [M2 (SP)]	Add 2 to SP and then load the contents of M2(SP) into reg. The relation between i1i0 and reg is the same as that for the PUSH reg instruction.																	
RT	Return from subroutine	0 0 0 1	1 1 0 0	1	2	SP ← (SP) + 4 PC ← [M4 (SP)]	Return from a subroutine or interrupt handling routine. ZF and CF are not restored.																	
RTI	Return from interrupt routine	0 0 0 1	1 1 0 1	1	2	SP ← (SP) + 4 PC ← [M4 (SP)] CF, ZF ← [M4 (SP)]	Return from a subroutine or interrupt handling routine. ZF and CF are restored.	ZF, CF																
[Branch instructions]																								
BAt2 addr	Branch on AC bit	1 1 0 1 P <sub>7</sub> P <sub>6</sub> P <sub>5</sub> P <sub>4</sub>	0 0 t <sub>1</sub> t <sub>0</sub> P <sub>3</sub> P <sub>2</sub> P <sub>1</sub> P <sub>0</sub>	2	2	PC7 to 0 ← P <sub>7</sub> P <sub>6</sub> P <sub>5</sub> P <sub>4</sub> P <sub>3</sub> P <sub>2</sub> P <sub>1</sub> P <sub>0</sub> if (AC, t <sub>2</sub> ) = 1	Branch to the location in the same page specified by P <sub>7</sub> to P <sub>0</sub> if the bit in AC specified by the immediate data t <sub>1</sub> t <sub>0</sub> is one.																	
BNAI2 addr	Branch on no AC bit	1 0 0 1 P <sub>7</sub> P <sub>6</sub> P <sub>5</sub> P <sub>4</sub>	0 0 t <sub>1</sub> t <sub>0</sub> P <sub>3</sub> P <sub>2</sub> P <sub>1</sub> P <sub>0</sub>	2	2	PC7 to 0 ← P <sub>7</sub> P <sub>6</sub> P <sub>5</sub> P <sub>4</sub> P <sub>3</sub> P <sub>2</sub> P <sub>1</sub> P <sub>0</sub> if (AC, t <sub>2</sub> ) = 0	Branch to the location in the same page specified by P <sub>7</sub> to P <sub>0</sub> if the bit in AC specified by the immediate data t <sub>1</sub> t <sub>0</sub> is zero.																	
BMt2 addr	Branch on M bit	1 1 0 1 P <sub>7</sub> P <sub>6</sub> P <sub>5</sub> P <sub>4</sub>	0 1 t <sub>1</sub> t <sub>0</sub> P <sub>3</sub> P <sub>2</sub> P <sub>1</sub> P <sub>0</sub>	2	2	PC7 to 0 ← P <sub>7</sub> P <sub>6</sub> P <sub>5</sub> P <sub>4</sub> P <sub>3</sub> P <sub>2</sub> P <sub>1</sub> P <sub>0</sub> if [M (HL), t <sub>2</sub> ] = 1	Branch to the location in the same page specified by P <sub>7</sub> to P <sub>0</sub> if the bit in M (HL) specified by the immediate data t <sub>1</sub> t <sub>0</sub> is one.																	
BNMt2 addr	Branch on no M bit	1 0 0 1 P <sub>7</sub> P <sub>6</sub> P <sub>5</sub> P <sub>4</sub>	0 1 t <sub>1</sub> t <sub>0</sub> P <sub>3</sub> P <sub>2</sub> P <sub>1</sub> P <sub>0</sub>	2	2	PC7 to 0 ← P <sub>7</sub> P <sub>6</sub> P <sub>5</sub> P <sub>4</sub> P <sub>3</sub> P <sub>2</sub> P <sub>1</sub> P <sub>0</sub> if [M (HL), t <sub>2</sub> ] = 0	Branch to the location in the same page specified by P <sub>7</sub> to P <sub>0</sub> if the bit in M (HL) specified by the immediate data t <sub>1</sub> t <sub>0</sub> is zero.																	
BPI2 addr	Branch on Port bit	1 1 0 1 P <sub>7</sub> P <sub>6</sub> P <sub>5</sub> P <sub>4</sub>	1 0 t <sub>1</sub> t <sub>0</sub> P <sub>3</sub> P <sub>2</sub> P <sub>1</sub> P <sub>0</sub>	2	2	PC7 to 0 ← P <sub>7</sub> P <sub>6</sub> P <sub>5</sub> P <sub>4</sub> P <sub>3</sub> P <sub>2</sub> P <sub>1</sub> P <sub>0</sub> if [P (DP <sub>L</sub> ), t <sub>2</sub> ] = 1	Branch to the location in the same page specified by P <sub>7</sub> to P <sub>0</sub> if the bit in port (DP <sub>L</sub> ) specified by the immediate data t <sub>1</sub> t <sub>0</sub> is one.	Internal control registers can also be tested by executing this instruction immediately after a BANK instruction. However, this is limited to registers that can be read out.																
BNPI2 addr	Branch on no Port bit	1 0 0 1 P <sub>7</sub> P <sub>6</sub> P <sub>5</sub> P <sub>4</sub>	1 0 t <sub>1</sub> t <sub>0</sub> P <sub>3</sub> P <sub>2</sub> P <sub>1</sub> P <sub>0</sub>	2	2	PC7 to 0 ← P <sub>7</sub> P <sub>6</sub> P <sub>5</sub> P <sub>4</sub> P <sub>3</sub> P <sub>2</sub> P <sub>1</sub> P <sub>0</sub> if [P (DP <sub>L</sub> ), t <sub>2</sub> ] = 0	Branch to the location in the same page specified by P <sub>7</sub> to P <sub>0</sub> if the bit in port (DP <sub>L</sub> ) specified by the immediate data t <sub>1</sub> t <sub>0</sub> is zero.	Internal control registers can also be tested by executing this instruction immediately after a BANK instruction. However, this is limited to registers that can be read out.																

Continued on next page.



Continued from preceding page.

Mnemonic	Instruction code	D <sub>7</sub> D <sub>6</sub> D <sub>5</sub> D <sub>4</sub>	D <sub>3</sub> D <sub>2</sub> D <sub>1</sub> D <sub>0</sub>	Number of bytes	Number of cycles	Operation	Description	Affected status bits	Note
[Branch instructions]									
BC addr	Branch on CF	1 1 0 1 P <sub>7</sub> P <sub>6</sub> P <sub>5</sub> P <sub>4</sub>	1 1 0 0 P <sub>3</sub> P <sub>2</sub> P <sub>1</sub> P <sub>0</sub>	2	2	PC7 to 0 ← P <sub>7</sub> P <sub>6</sub> P <sub>5</sub> P <sub>4</sub> P <sub>3</sub> P <sub>2</sub> P <sub>1</sub> P <sub>0</sub> if (CF) = 1	Branch to the location in the same page specified by P <sub>7</sub> to P <sub>0</sub> if CF is one.		
BNC addr	Branch on no CF	1 0 0 1 P <sub>7</sub> P <sub>6</sub> P <sub>5</sub> P <sub>4</sub>	1 1 0 0 P <sub>3</sub> P <sub>2</sub> P <sub>1</sub> P <sub>0</sub>	2	2	PC7 to 0 ← P <sub>7</sub> P <sub>6</sub> P <sub>5</sub> P <sub>4</sub> P <sub>3</sub> P <sub>2</sub> P <sub>1</sub> P <sub>0</sub> if (CF) = 0	Branch to the location in the same page specified by P <sub>7</sub> to P <sub>0</sub> if CF is zero.		
BZ addr	Branch on ZF	1 1 0 1 P <sub>7</sub> P <sub>6</sub> P <sub>5</sub> P <sub>4</sub>	1 1 0 1 P <sub>3</sub> P <sub>2</sub> P <sub>1</sub> P <sub>0</sub>	2	2	PC7 to 0 ← P <sub>7</sub> P <sub>6</sub> P <sub>5</sub> P <sub>4</sub> P <sub>3</sub> P <sub>2</sub> P <sub>1</sub> P <sub>0</sub> if (ZF) = 1	Branch to the location in the same page specified by P <sub>7</sub> to P <sub>0</sub> if ZF is one.		
BNZ addr	Branch on no ZF	1 0 0 1 P <sub>7</sub> P <sub>6</sub> P <sub>5</sub> P <sub>4</sub>	1 1 0 1 P <sub>3</sub> P <sub>2</sub> P <sub>1</sub> P <sub>0</sub>	2	2	PC7 to 0 ← P <sub>7</sub> P <sub>6</sub> P <sub>5</sub> P <sub>4</sub> P <sub>3</sub> P <sub>2</sub> P <sub>1</sub> P <sub>0</sub> if (ZF) = 0	Branch to the location in the same page specified by P <sub>7</sub> to P <sub>0</sub> if ZF is zero.		
BFn4 addr	Branch on flag bit	1 1 1 1 P <sub>7</sub> P <sub>6</sub> P <sub>5</sub> P <sub>4</sub>	n <sub>3</sub> n <sub>2</sub> n <sub>1</sub> n <sub>0</sub> P <sub>3</sub> P <sub>2</sub> P <sub>1</sub> P <sub>0</sub>	2	2	PC7 to 0 ← P <sub>7</sub> P <sub>6</sub> P <sub>5</sub> P <sub>4</sub> P <sub>3</sub> P <sub>2</sub> P <sub>1</sub> P <sub>0</sub> if (Fn) = 1	Branch to the location in the same page specified by P <sub>0</sub> to P <sub>7</sub> if the flag (of the 16 user flags) specified by n <sub>3</sub> n <sub>2</sub> n <sub>1</sub> n <sub>0</sub> is one.		
BNFn4 addr	Branch on no flag bit	1 0 1 1 P <sub>7</sub> P <sub>6</sub> P <sub>5</sub> P <sub>4</sub>	n <sub>3</sub> n <sub>2</sub> n <sub>1</sub> n <sub>0</sub> P <sub>3</sub> P <sub>2</sub> P <sub>1</sub> P <sub>0</sub>	2	2	PC7 to 0 ← P <sub>7</sub> P <sub>6</sub> P <sub>5</sub> P <sub>4</sub> P <sub>3</sub> P <sub>2</sub> P <sub>1</sub> P <sub>0</sub> if (Fn) = 0	Branch to the location in the same page specified by P <sub>0</sub> to P <sub>7</sub> if the flag (of the 16 user flags) specified by n <sub>3</sub> n <sub>2</sub> n <sub>1</sub> n <sub>0</sub> is zero.		
[I/O instructions]									
IP0	Input port 0 to AC	0 0 1 0	0 0 0 0	1	1	AC ← (P0)	Input the contents of port 0 to AC.	ZF	
IP	Input port to AC	0 0 1 0	0 1 1 0	1	1	AC ← [P (DP <sub>L</sub> )]	Input the contents of port P (DP <sub>L</sub> ) to AC.	ZF	
IPM	Input port to M	0 0 0 1	1 0 0 1	1	1	M (HL) ← [P (DP <sub>L</sub> )]	Input the contents of port P (DP <sub>L</sub> ) to M (HL).		
IPDR i4	Input port to AC direct	1 1 0 0 0 1 1 0	1 1 1 1 i <sub>3</sub> i <sub>2</sub> i <sub>1</sub> i <sub>0</sub>	2	2	AC ← [P (i4)]	Input the contents of P (i4) to AC.	ZF	
IP45	Input port 4, 5 to E, AC respectively	1 1 0 0 1 1 0 1	1 1 1 1 0 1 0 0	2	2	E ← [P (4)] AC ← [P (5)]	Input the contents of ports P (4) and P (5) to E and AC respectively.		
OP	Output AC to port	0 0 1 0	0 1 0 1	1	1	P (DP <sub>L</sub> ) ← (AC)	Output the contents of AC to port P (DP <sub>L</sub> ).		
OPM	Output M to port	0 0 0 1	1 0 1 0	1	1	P (DP <sub>L</sub> ) ← [M (HL)]	Output the contents of M (HL) to port P (DP <sub>L</sub> ).		
OPDR i4	Output AC to port direct	1 1 0 0 0 1 1 1	1 1 1 1 i <sub>3</sub> i <sub>2</sub> i <sub>1</sub> i <sub>0</sub>	2	2	P (i4) ← (AC)	Output the contents of AC to P (i4).		
OP45	Output E, AC to port 4, 5 respectively	1 1 0 0 1 1 0 1	1 1 1 1 0 1 0 1	2	2	P (4) ← (E) P (5) ← (AC)	Output the contents of E and AC to ports P (4) and P (5) respectively.		
SPB t2	Set port bit	0 0 0 0	1 0 t <sub>1</sub> t <sub>0</sub>	1	1	[P (DP <sub>L</sub> ), t2] ← 1	Set to one the bit in port P (DP <sub>L</sub> ) specified by the immediate data t <sub>1</sub> t <sub>0</sub> .		
RPB t2	Reset port bit	0 0 1 0	1 0 t <sub>1</sub> t <sub>0</sub>	1	1	[P (DP <sub>L</sub> ), t2] ← 0	Clear to zero the bit in port P (DP <sub>L</sub> ) specified by the immediate data t <sub>1</sub> t <sub>0</sub> .	ZF	
ANDPDR i4, p4	And port with immediate data then output	1 1 0 0 i <sub>3</sub> i <sub>2</sub> i <sub>1</sub> i <sub>0</sub>	0 1 0 1 P <sub>3</sub> P <sub>2</sub> P <sub>1</sub> P <sub>0</sub>	2	2	P (P <sub>3</sub> to P <sub>0</sub> ) ← [P (P <sub>3</sub> to P <sub>0</sub> )] ∨ i <sub>3</sub> to i <sub>0</sub>	Take the logical AND of P (P <sub>3</sub> to P <sub>0</sub> ) and the immediate data i <sub>3</sub> i <sub>2</sub> i <sub>1</sub> i <sub>0</sub> and output the result to P (P <sub>3</sub> to P <sub>0</sub> ).	ZF	
ORPDR i4, p4	Or port with immediate data then output	1 1 0 0 i <sub>3</sub> i <sub>2</sub> i <sub>1</sub> i <sub>0</sub>	0 1 0 0 P <sub>3</sub> P <sub>2</sub> P <sub>1</sub> P <sub>0</sub>	2	2	P (P <sub>3</sub> to P <sub>0</sub> ) ← [P (P <sub>3</sub> to P <sub>0</sub> )] ∨ i <sub>3</sub> to i <sub>0</sub>	Take the logical OR of P (P <sub>3</sub> to P <sub>0</sub> ) and the immediate data i <sub>3</sub> i <sub>2</sub> i <sub>1</sub> i <sub>0</sub> and output the result to P (P <sub>3</sub> to P <sub>0</sub> ).	ZF	

Continued on next page.

Continued from preceding page.

Mnemonic	Instruction code	D <sub>7</sub> D <sub>6</sub> D <sub>5</sub> D <sub>4</sub>	D <sub>3</sub> D <sub>2</sub> D <sub>1</sub> D <sub>0</sub>	Number of bytes	Number of cycles	Operation	Description	Affected status bits	Note
[Timer control instructions]									
WTTM0	Write timer 0	1 1 0 0	1 0 1 0	1	2	TIMER0 ← [M2 (HL)], (AC)	Write the contents of M2 (HL), AC into the timer 0 reload register.		
WTTM1	Write timer 1	1 1 0 0 1 1 1 1	1 1 1 1 0 1 0 0	2	2	TIMER1 ← (E), (AC)	Write the contents of E, AC into the timer 1 reload register A.		
RTIM0	Read timer 0	1 1 0 0	1 0 1 1	1	2	M2 (HL), AC ← (TIMER0)	Read out the contents of the timer 0 counter into M2 (HL), AC.		
RTIM1	Read timer 1	1 1 0 0 1 1 1 1	1 1 1 1 0 1 0 1	2	2	E, AC ← (TIMER1)	Read out the contents of the timer 1 counter into E, AC.		
START0	Start timer 0	1 1 0 0 1 1 1 0	1 1 1 1 0 1 1 0	2	2	Start timer 0 counter	Start the timer 0 counter.		
START1	Start timer 1	1 1 0 0 1 1 1 0	1 1 1 1 0 1 1 1	2	2	Start timer 1 counter	Start the timer 1 counter.		
STOP0	Stop timer 0	1 1 0 0 1 1 1 1	1 1 1 1 0 1 1 0	2	2	Stop timer 0 counter	Stop the timer 0 counter.		
STOP1	Stop timer 1	1 1 0 0 1 1 1 1	1 1 1 1 0 1 1 1	2	2	Stop timer 1 counter	Stop the timer 1 counter.		
[Interrupt control instructions]									
MSET	Set interrupt master enable flag	1 1 0 0 0 1 0 1	1 1 0 1 0 0 0 0	2	2	MSE ← 1	Set the interrupt master enable flag to one.		
MRESET	Reset interrupt master enable flag	1 1 0 0 1 0 0 1	1 1 0 1 0 0 0 0	2	2	MSE ← 0	Clear the interrupt master enable flag to zero.		
EIH i4	Enable interrupt high	1 1 0 0 0 1 0 1	1 1 0 1 i <sub>3</sub> i <sub>2</sub> i <sub>1</sub> i <sub>0</sub>	2	2	EDIH ← (EDIH) ∨ i4	Set the interrupt enable flag to one.		
EIL i4	Enable interrupt low	1 1 0 0 0 1 0 0	1 1 0 1 i <sub>3</sub> i <sub>2</sub> i <sub>1</sub> i <sub>0</sub>	2	2	EDIL ← (EDIL) ∨ i4	Set the interrupt enable flag to one.		
DIH i4	Disable interrupt high	1 1 0 0 1 0 0 1	1 1 0 1 i <sub>3</sub> i <sub>2</sub> i <sub>1</sub> i <sub>0</sub>	2	2	EDIH ← (EDIH) ∧ i <sub>4</sub>	Clear the interrupt enable flag to zero.	ZF	
DIL i4	Disable interrupt low	1 1 0 0 1 0 0 0	1 1 0 1 i <sub>3</sub> i <sub>2</sub> i <sub>1</sub> i <sub>0</sub>	2	2	EDIL ← (EDIL) ∧ i <sub>4</sub>	Clear the interrupt enable flag to zero.	ZF	
WTSP	Write SP	1 1 0 0 1 1 0 1	1 1 1 1 1 0 1 0	2	2	SP ← (E), (AC)	Transfer the contents of E, AC to SP.		
RSP	Read SP	1 1 0 0 1 1 0 1	1 1 1 1 1 0 1 1	2	2	E, AC ← (SP)	Transfer the contents of SP to E, AC.		
[Standby control instructions]									
HALT	HALT	1 1 0 0 1 1 0 1	1 1 1 1 1 1 1 0	2	2	HALT	Enter halt mode.		
HOLD	HOLD	1 1 0 0 1 1 0 1	1 1 1 1 1 1 1 1	2	2	HOLD	Enter hold mode.		
[Serial I/O control instructions]									
STARTS	Start serial I O	1 1 0 0 1 1 1 0	1 1 1 1 1 1 1 0	2	2	START SIO	Start SIO operation.		
WTSIO	Write serial I O	1 1 0 0 1 1 1 0	1 1 1 1 1 1 1 1	2	2	SIO ← (E), (AC)	Write the contents of E, AC to SIO.		
RSIO	Read serial I O	1 1 0 0 1 1 1 1	1 1 1 1 1 1 1 1	2	2	E, AC ← (SIO)	Read out the contents of SIO into E, AC.		
[Other instructions]									
NOP	No operation	0 0 0 0	0 0 0 0	1	1	No operation	Consume one machine cycle without performing any operation.		
SB i2	Select bank	1 1 0 0 1 1 0 0	1 1 1 1 0 0 i <sub>1</sub> i <sub>0</sub>	2	2	PC13, PC12 ← i <sub>1</sub> i <sub>0</sub>	Specify the memory bank.		

- No products described or contained herein are intended for use in surgical implants, life-support systems, aerospace equipment, nuclear power control systems, vehicles, disaster/crime-prevention equipment and the like, the failure of which may directly or indirectly cause injury, death or property loss.
- Anyone purchasing any products described or contained herein for an above-mentioned use shall:
  - ① Accept full responsibility and indemnify and defend SANYO ELECTRIC CO., LTD., its affiliates, subsidiaries and distributors and all their officers and employees, jointly and severally, against any and all claims and litigation and all damages, cost and expenses associated with such use:
  - ② Not impose any responsibility for any fault or negligence which may be cited in any such claim or litigation on SANYO ELECTRIC CO., LTD., its affiliates, subsidiaries and distributors or any of their officers and employees jointly or severally.
- Information (including circuit diagrams and circuit parameters) herein is for example only; it is not guaranteed for volume production. SANYO believes information herein is accurate and reliable, but no guarantees are made or implied regarding its use or any infringements of intellectual property rights or other rights of third parties.

This catalog provides information as of February, 1997. Specifications and information herein are subject to change without notice.