

DATA SHEET

LLE18150X

**NPN silicon planar epitaxial
microwave power transistor**

Product specification
File under Discrete Semiconductors, SC15

September 1994

Philips Semiconductors



PHILIPS

NPN silicon planar epitaxial microwave power transistor

LLE18150X

FEATURES

- Diffused emitter ballasting resistors providing excellent current sharing and withstanding a high VSWR
- Interdigitated structure provides high emitter efficiency
- Gold metallization realizes very good stability of the characteristics and excellent lifetime
- Multicell geometry gives good balance of dissipated power and low thermal resistance
- Internal input and output prematching ensures good stability and allows an easier design of wideband circuits.

APPLICATION

Intended for use in common emitter, class AB amplifiers in CW conditions for professional applications between 1.7 GHz and 2.0 GHz.

DESCRIPTION

NPN silicon planar epitaxial microwave power transistor in a FO-229 glued cap metal ceramic flange package, with emitter connected to flange.

QUICK REFERENCE DATA

Microwave performance up to $T_{mb} = 25\text{ }^\circ\text{C}$ in a common emitter class AB amplifier.

MODE OF OPERATION	f (GHz)	V _{CE} (V)	I _{CQ} (A)	P _{L1} (W)	G _{po} (dB)	η _c (%)	Z _i ; Z _L (Ω)
Class AB (CW)	1.85	24	0.05	≥12	≥7.8	typ. 43	see Figs 6 and 7

PINNING - FO-229

PIN	DESCRIPTION
1	collector
2	base
3	emitter connected to flange

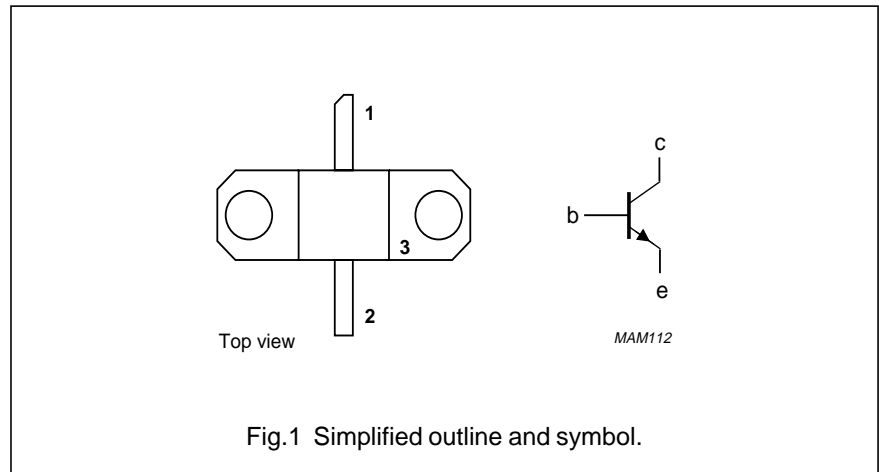

WARNING

Product and environmental safety - toxic materials

This product contains beryllium oxide. The product is entirely safe provided that the BeO slab is not damaged. All persons who handle, use or dispose of this product should be aware of its nature and of the necessary safety precautions. After use, dispose of as chemical or special waste according to the regulations applying at the location of the user. It must never be thrown out with the general or domestic waste.

**NPN silicon planar epitaxial
microwave power transistor**

LLE18150X

LIMITING VALUES

In accordance with the Absolute Maximum Rating System (IEC 134).

SYMBOL	PARAMETER	CONDITIONS	MIN.	MAX.	UNIT
V _{CBO}	collector-base voltage	open emitter	–	45	V
V _{CER}	collector-emitter voltage	R _{BE} = 220 Ω	–	30	V
V _{CEO}	collector-emitter voltage	open base	–	22	V
V _{EBO}	emitter-base voltage	open collector	–	3	V
I _C	DC collector current		–	3	A
P _i	input power	f = 1.85 GHz; V _{CE} = 24 V; class AB	–	4	W
P _{tot}	total power dissipation	T _{mb} = 75 °C	–	25	W
T _{stg}	storage temperature		–65	+150	°C
T _j	junction temperature		–	200	°C
T _{slid}	soldering temperature	t ≤ 10 s; note 1	–	235	°C

Note

- Up to 0.2 mm from ceramic.

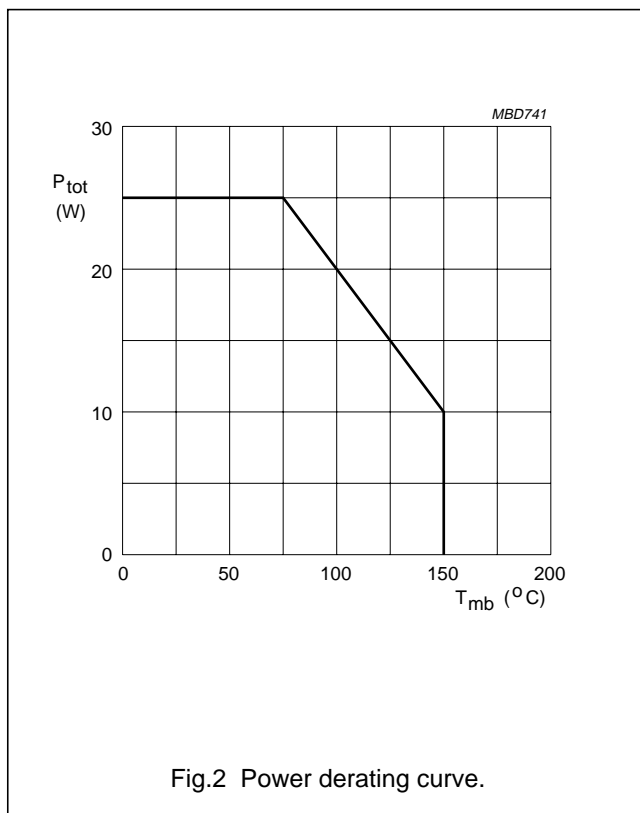

NPN silicon planar epitaxial microwave power transistor

LLE18150X

THERMAL CHARACTERISTICS

SYMBOL	PARAMETER	CONDITIONS	MAX.	UNIT
$R_{th\ j-mb}$	thermal resistance from junction to mounting base	$T_j = 100\text{ °C}$	3.6	K/W
$R_{th\ mb-h}$	thermal resistance from mounting base to heatsink		0.2	K/W

CHARACTERISTICS

$T_{mb} = 25\text{ °C}$ unless otherwise specified.

SYMBOL	PARAMETER	CONDITIONS	MIN.	MAX.	UNIT
I_{CBO}	collector cut-off current	$I_E = 0; V_{CB} = 20\text{ V}$	–	1.5	mA
$V_{(BR)CER}$	collector-emitter breakdown voltage	$I_C = 0\text{ mA}; R_{BE} = 220\ \Omega$	30	–	V
$V_{(BR)CBO}$	collector-base breakdown voltage	$I_C = 10\text{ mA}$	45	–	V
$V_{(BR)EBO}$	emitter-base breakdown voltage	$I_E = 10\text{ mA}$	3	–	V
h_{FE}	DC current gain	$I_C = 0.5\text{ A}; V_{CE} = 3\text{ V}$	15	100	

APPLICATION INFORMATION

Microwave performance up to $T_{mb} = 25\text{ °C}$ in a common emitter class AB amplifier.

MODE OF OPERATION	f (GHz)	V_{CE} (V)	I_{CQ} (A)	P_{L1} (W)	G_{po} (dB)	η_c (%)	$Z_i; Z_L$ (Ω)
Class AB (CW)	1.85	24	0.05	≥ 12 typ. 15	≥ 7.8 typ. 8.5	typ. 43	see Figs 6 and 7

NPN silicon planar epitaxial
microwave power transistor

LLE18150X

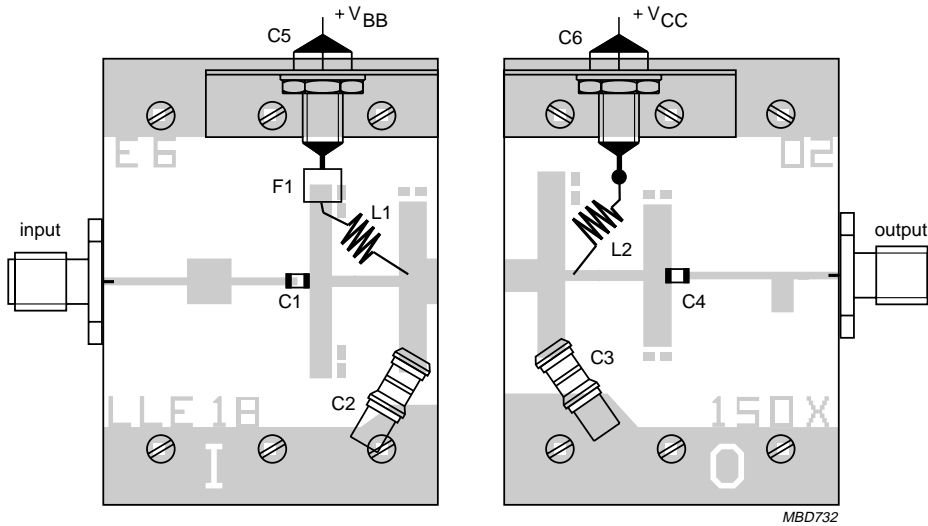
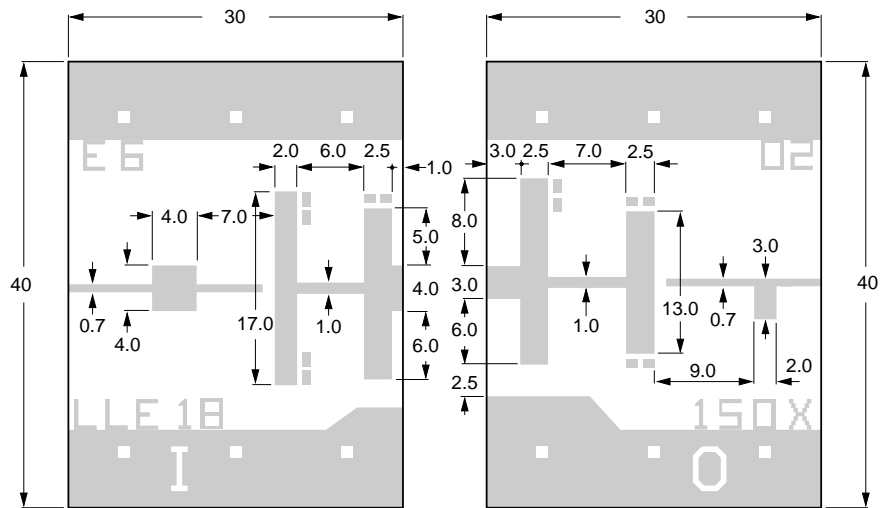

The test circuit is split into two independent halves, each being 30 x 40 mm in size.
 Dimensions in mm.
 Substrate: Epsilam 10.
 Thickness: 0.635 mm.
 Permittivity: $\epsilon_r = 10$.

Fig.3 Prematching test circuit board.

NPN silicon planar epitaxial
microwave power transistor

LLE18150X

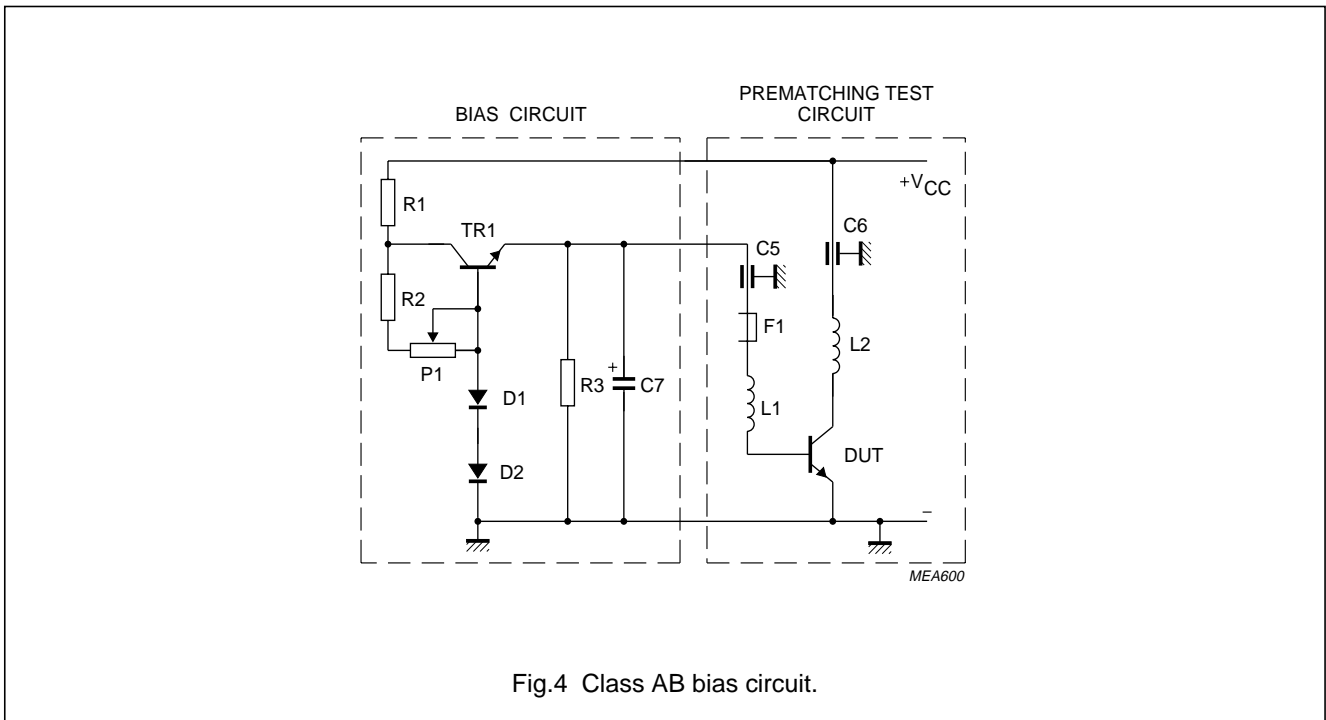

List of components (see Figs 3 and 4).

COMPONENT	DESCRIPTION	VALUE	ORDERING INFORMATION
TR1	transistor, BDT91 or equivalent		
C1, C4	DC blocking chip capacitor	100 pF	ATC 100A101kp
C2, C3	trimmer capacitor	0.5 to 5.0 pF	Tekelec 727-1
C5, C6	feedthrough bypass capacitor	1500 pF	Erie 1250-003
C7	electrolytic capacitor	10 μ F, >30 V	
D1	diode BY239 or equivalent; note 1		
D2	diode BY239 or equivalent; note 2		
L1	4 turns 0.5 mm copper wire; internal diameter = 2 mm		
L2	4 turns 0.5 mm copper wire; internal diameter = 2 mm		
P1	linear potentiometer	4.7 k Ω	
R1	resistor	100 Ω , 0.25 W	
R2	resistor	10 k Ω , 0.25 W	
R3	resistor	56 Ω , 0.25 W	
F1	ferrite bead		Philips tube, 12NC = 4330 030 43081 4.2 x 2.2 x 3.2 mm (4B1)

Notes

1. In thermal contact with TR1.
2. In thermal contact with DUT.

NPN silicon planar epitaxial
microwave power transistor

LLE18150X

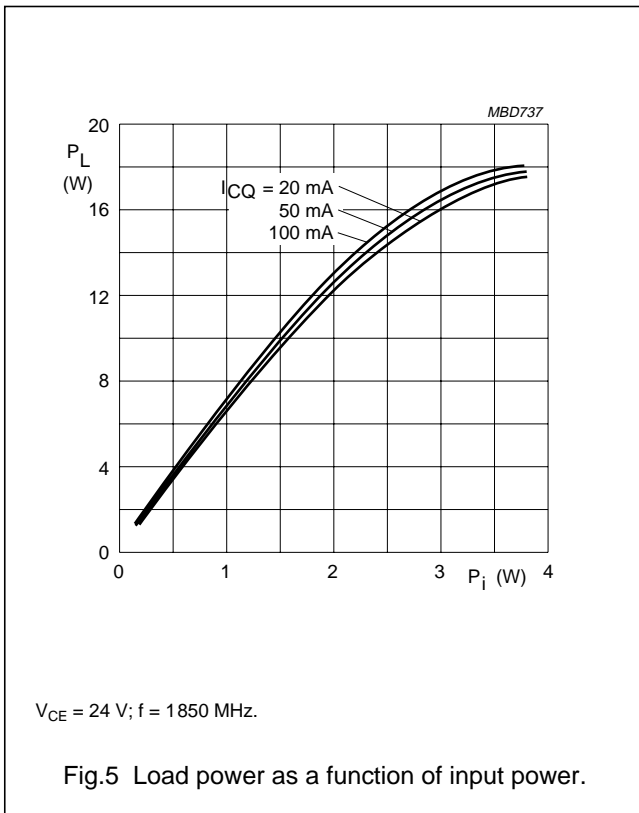

Input and optimum load impedances.

$V_{CE} = 24\text{ V}; I_{CQ} = 50\text{ mA}; Z_o = 10\ \Omega$ (see Figs 6 and 7);
typical values at $P_L = P_{L1}$.

f (GHz)	Z_i (Ω)	Z_L (Ω)
1.70	$4.5 + j8.0$	$6.2 - j0.5$
1.80	$7.5 + j9.0$	$5.7 - j1.0$
1.85	$9.2 + j8.2$	$4.7 - j1.7$
1.90	$9.5 + j6.5$	$3.9 - j2.2$
2.00	$7.0 + j3.0$	$2.7 - j2.4$

NPN silicon planar epitaxial
microwave power transistor

LLE18150X

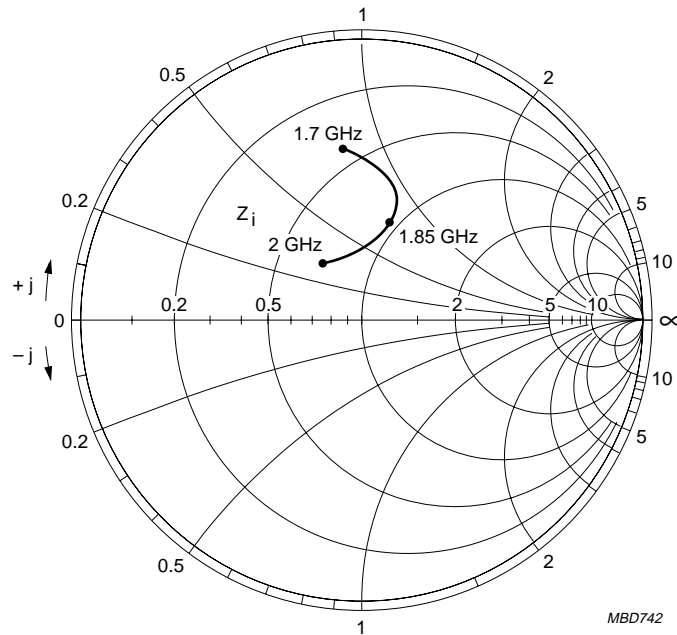

$V_{CE} = 24 \text{ V}$; $Z_0 = 10 \Omega$; $I_{CQ} = 50 \text{ mA}$.

Fig.6 Input impedance as a function of frequency; typical values at $P_L = P_{L1}$

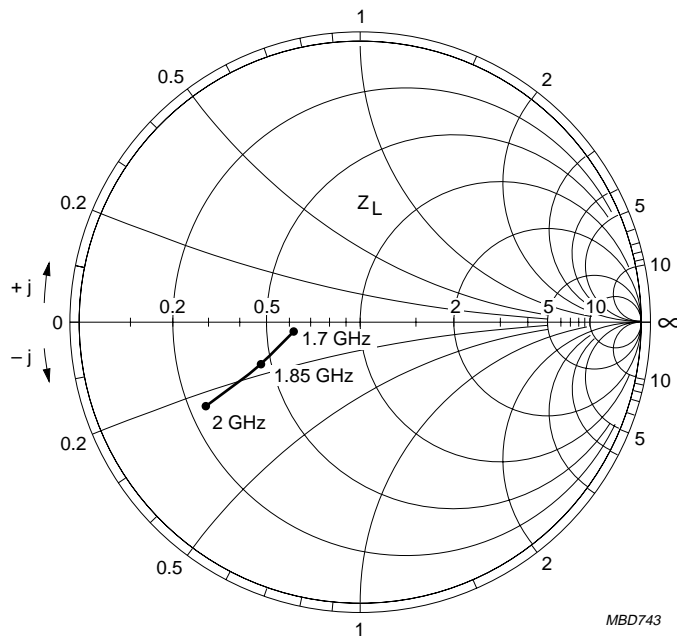

$V_{CE} = 24 \text{ V}$; $Z_0 = 10 \Omega$; $I_{CQ} = 50 \text{ mA}$.

Fig.7 Optimum load impedance as a function of frequency; typical values at $P_L = P_{L1}$.

NPN silicon planar epitaxial
microwave power transistor

LLE18150X

PACKAGE OUTLINE

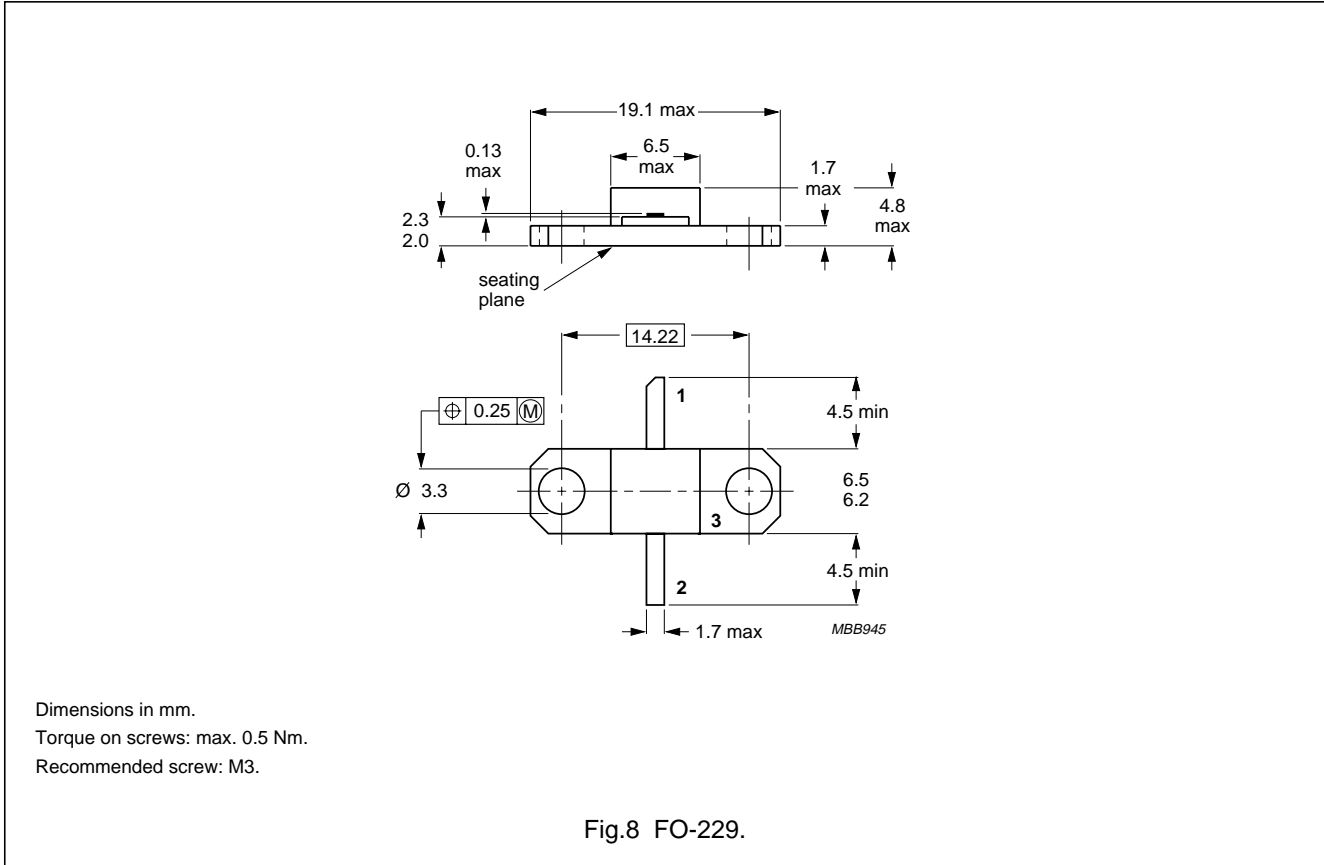

DEFINITIONS

Data Sheet Status	
Objective specification	This data sheet contains target or goal specifications for product development.
Preliminary specification	This data sheet contains preliminary data; supplementary data may be published later.
Product specification	This data sheet contains final product specifications.
Limiting values	
Limiting values given are in accordance with the Absolute Maximum Rating System (IEC 134). Stress above one or more of the limiting values may cause permanent damage to the device. These are stress ratings only and operation of the device at these or at any other conditions above those given in the Characteristics sections of the specification is not implied. Exposure to limiting values for extended periods may affect device reliability.	
Application information	
Where application information is given, it is advisory and does not form part of the specification.	

LIFE SUPPORT APPLICATIONS

These products are not designed for use in life support appliances, devices, or systems where malfunction of these products can reasonably be expected to result in personal injury. Philips customers using or selling these products for use in such applications do so at their own risk and agree to fully indemnify Philips for any damages resulting from such improper use or sale.