



# LM134 LM234 - LM334

## THREE TERMINAL ADJUSTABLE CURRENT SOURCES

- OPERATES FROM 1V TO 40V
- 0.02%/V CURRENT REGULATION
- PROGRAMMABLE FROM 1 $\mu$ A TO 10mA
- $\pm$ 3% INITIAL ACCURACY

### DESCRIPTION

The LM134/LM234/LM334 are 3-terminal adjustable current sources characterized by:

- an operating current range of 10000: 1
- an excellent current regulation
- a wide dynamic voltage range of 1V t 10V

The current is determined by an external resistor without requiring other external components.

Reverse voltages of up to 20V will only draw a current of several microamperes. This enables the circuit to operate as a rectifier and as a source of current in a.c. applications.

For the LM134/LM234/LM334, the voltage on the control pin is 64mV at +25°C and is directly proportional to the absolute temperature ( $^{\circ}$ K). The simplest external resistor connection generates a current with  $\approx$  0.33%/ $^{\circ}$ C temperature dependence. Zero drift can be obtained by adding an additional resistor and a diode to the external circuit.

### PIN CONNECTIONS (top view)

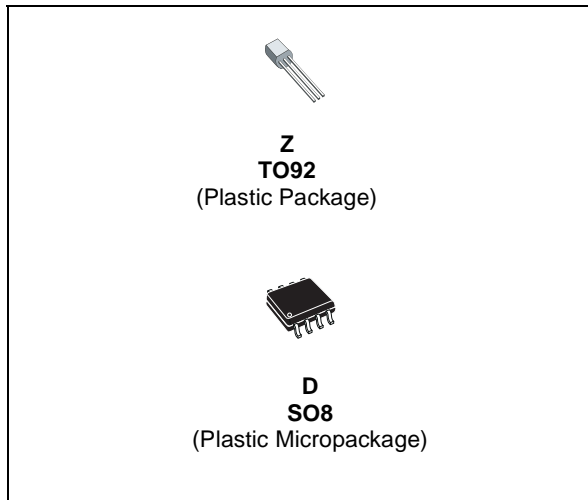
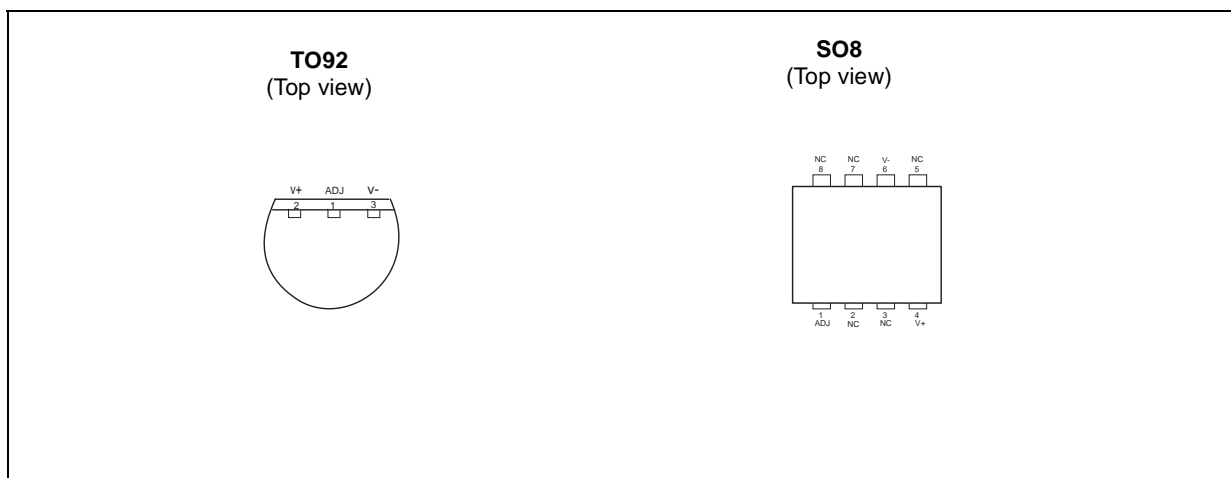

### ORDER CODE

Part Number	Temperature Range	Package	
		Z	D
LM134	-55°C, +125°C	•	•
LM234	-25°C, +100°C	•	•
LM334	0°C, +70°C	•	•

Z = TO92 Plastic package - also available in Bulk (Z), Tape & Reel (ZT) and Ammo Pack (AP)  
D = Small Outline Package (SO) - also available in Tape & Reel (DT)

# LM134 - LM234 - LM334

## SCHEMATIC DIAGRAM

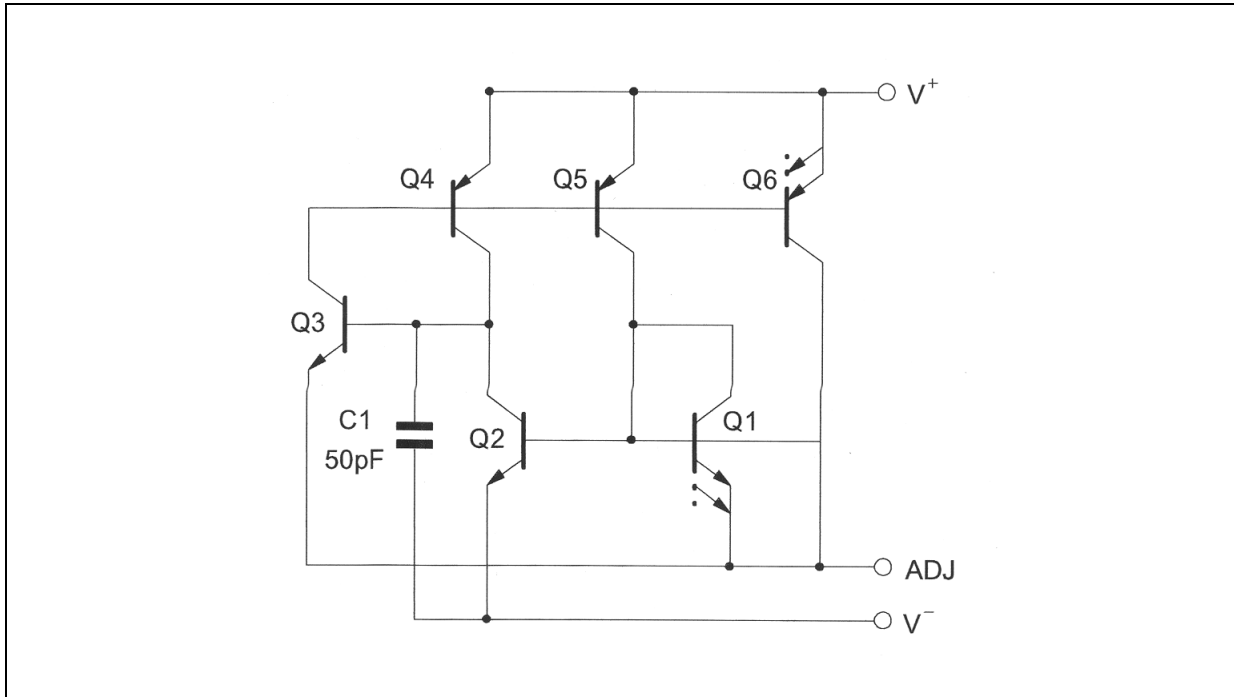

## ABSOLUTE MAXIMUM RATINGS

Symbol	Parameter	LM134	LM234	LM334	Unit
	Voltage V+ to V- Forward Reverse	40 20		30 20	V
$V_{ADJ^-}$	ADJ Pin to V- Voltage	5			V
$I_{SET}$	Set Current	10			mA
$P_{tot}$	Power Dissipation	400			mW
$T_{Stg}$	Storage Temperature Range	-65 to +150			°C
$T_{oper}$	Operating Free-air Temperature Range	-55 to +125	-25 to +100	0 to +70	°C

**ELECTRICAL CHARACTERISTICS**

T<sub>j</sub> = +25°C with pulse testing so that junction temperature does not change during testing (unless otherwise specified)

Parameter	LM134 - LM234			LM334			Unit
	Min.	Typ.	Max.	Min.	Typ.	Max.	
Set Current Error (V <sup>+</sup> = +2.5V) <sup>-1)</sup> 10µA ≤ I <sub>SET</sub> ≤ 1mA 1mA ≤ I <sub>SET</sub> ≤ 5mA 2µA ≤ I <sub>SET</sub> ≤ 10µA			3 5 8			6 8 12	%
Ratio of Set Current to V <sub>-</sub> Current 10µA ≤ I <sub>SET</sub> ≤ 1mA 1mA ≤ I <sub>SET</sub> ≤ 5mA 2µA ≤ I <sub>SET</sub> ≤ 10µA	14	18 14 14	23	14	18 14 14	26	
Minimum Operating Voltage 2µA ≤ I <sub>SET</sub> ≤ 100µA 100µA ≤ I <sub>SET</sub> ≤ 1mA 1mA ≤ I <sub>SET</sub> ≤ 5mA		0.8 0.9 1			0.8 0.9 1		V
Average Change in Set Current with Input Voltage 2µA ≤ I <sub>SET</sub> ≤ 1mA +1.5V ≤ V <sub>+</sub> ≤ +5V +5V ≤ V <sub>+</sub> ≤ +40V 1mA ≤ I <sub>SET</sub> ≤ 5mA +1.5V ≤ V <sub>+</sub> ≤ +5V +5V ≤ V <sub>+</sub> ≤ +40V		0.02 0.01	0.05 0.03		0.02 0.01	0.1 0.05	% / V
Temperature Dependence of set current - <sup>2)</sup> 25µA ≤ I <sub>SET</sub> ≤ 1mA	0.96 T	T	1.04 T	0.96 T	T	1.04 T	
Effective Shunt Capacitance		15			15		pF

- Set current is the current flowing into the V<sub>+</sub> pin. It is determined by the following formula I<sub>set</sub> = 67.7mV/R<sub>set</sub> (T<sub>j</sub> = +25°C)  
Set current error is expressed as a percent deviation from this amount
- I<sub>set</sub> is directly proportional to absolute temperature (°K). I<sub>set</sub> at any temperature can be calculated from I<sub>set</sub> = I<sub>o</sub> (T/T<sub>o</sub>) where I<sub>o</sub> is I<sub>set</sub> measured at T<sub>o</sub> (°K)

**OUTPUT IMPEDANCE**

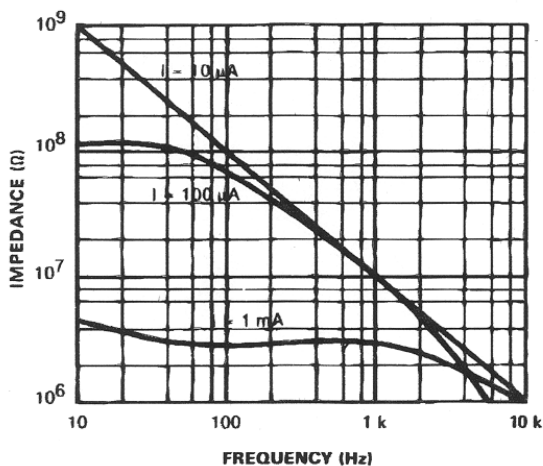

**MAXIMUM SLEW RATE FOR LINEAR OPERATION**

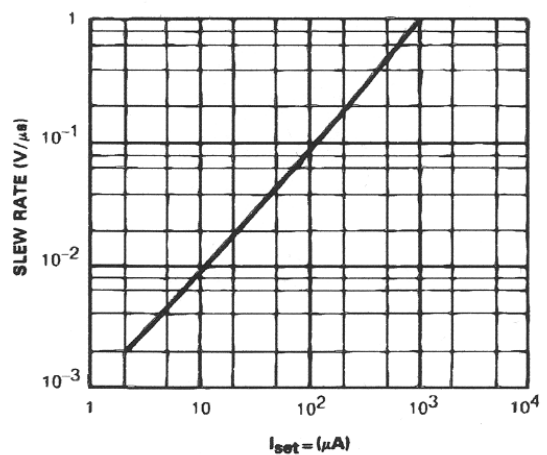

START UP

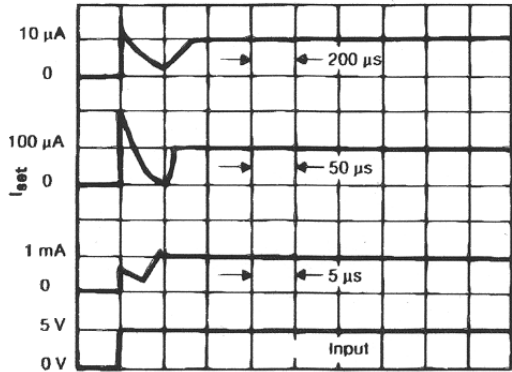

TIME (SCALE CHANGES AT EACH CURRENT LEVEL).

TRANSIENT RESPONSE

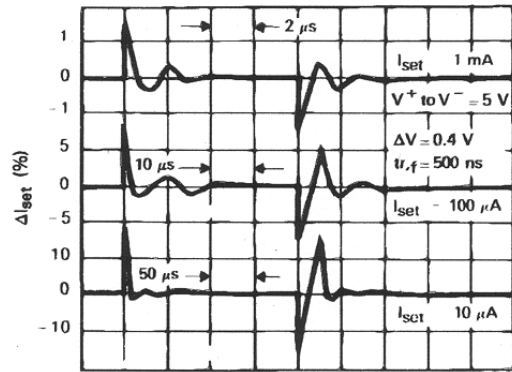

TIME (SCALE CHANGES AT EACH CURRENT LEVEL).

VOLTAGE ACROSS R\_set

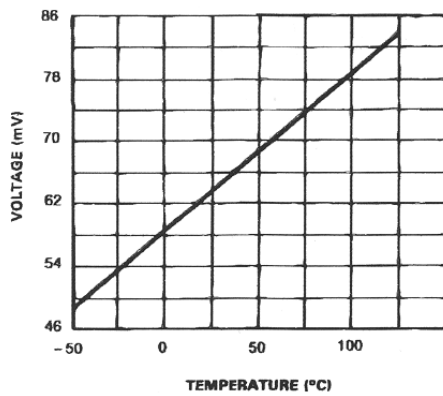

CURRENT NOISE

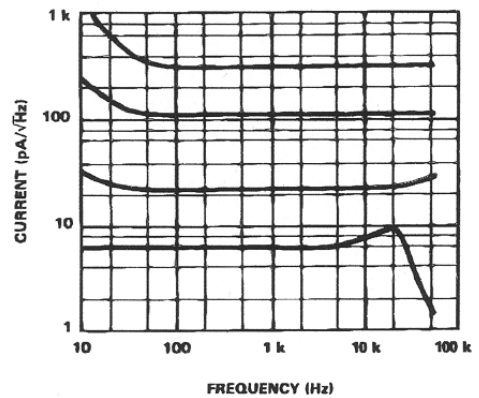

TURN-ON VOLTAGE

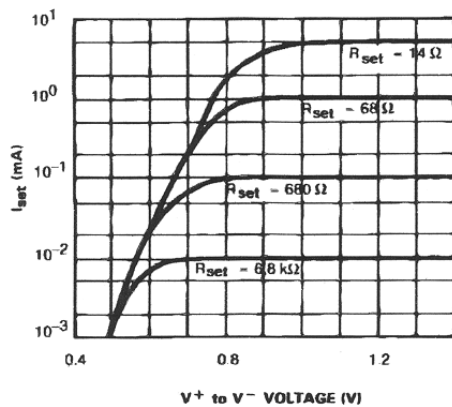

RATIO OF I\_set to V- CURRENT

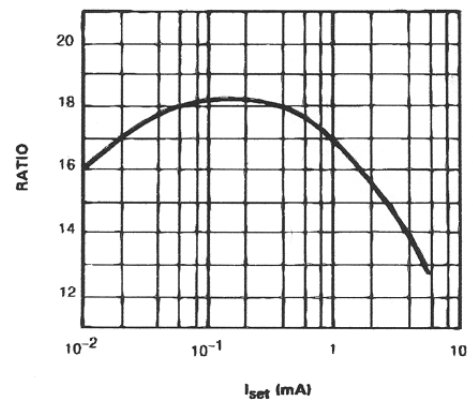

**APPLICATION HINTS**

**SLEW RATE**

At slew rates above a threshold (see curve) the LM134, LM234, LM334 can have a non-linear current characteristic. The slew rate at which this takes place is directly proportional to I<sub>set</sub>. At I<sub>set</sub> = 10µA, dv/dt max. = 0.01V/µs ; at I<sub>set</sub> = 1mA, dv/dt max. = 1V/µs. Slew rates of more than 1V/µs do not damage the circuit nor do they produce high currents.

**THERMAL EFFECTS**

Internal heating can have a significant effect on current regulation for an I<sub>set</sub> above 100µA. For example, each increase of 1V in the voltage across the LM134 at I<sub>set</sub> = 1mA will increase the junction temperature by ≈ 0.4°C (in still air). The output current (I<sub>set</sub>) has a temperature coefficient of about 0.33%/°C. Thus the change in current due to the increase in temperature will be (0.4) (0.33) = 0.132%. This is degradation of 10 : 1 in regulation versus the true electrical effects. Thermal effects should be taken into account when d.c. regulation is critical and I<sub>set</sub> is higher than 100µA.

**SHUNT CAPACITANCE**

In certain applications, the 15pF value for the shunt capacitance should be reduced :

- because of loading problems,
- because of limitation of output impedance of the current source in a.c. applications. This reduction of capacitance can be easily carried out by adding a FET as indicated in the typical applications.

The value of this capacitance can be reduced by at least 3pF and regulation can be improved by an order of magnitude without any modifications of the d.c. characteristics (except for the minimum input voltage).

**NOISE**

The current noise produced by LM134, LM234, LM334 is about 4 times that of a transistor. If the LM134, LM234, LM334 is used as an active load for a transistor amplifier, the noise at the input will increase by about 12dB. In most cases this is acceptable, and a single amplifier can be built with a voltage gain higher than 2000.

**LEAD RESISTANCE**

The sense voltage which determines the current of the LM134, LM234, LM334 is less than 100mV. At this level, the thermocouple effects and the connection resistance should be reduced by locating the current setting resistor close to the device. Do not use sockets for the ICs. A contact resistance of 0.7Ω is sufficient to decrease the output current by 1% at the 1mA level.

**SENSING TEMPERATURE**

The LM134, LM234, LM334 are excellent remote controlled temperature sensors because their operation as current sources preserves their accuracy even in the case of long connecting wires. The output current is directly proportional to the absolute temperature in Kelvin degrees according to the following equation.

$$I_{set} = \frac{(227\mu V/^{\circ}K) (T)}{R_{set}}$$

The calibration of the LM134, LM234, LM334 is simplified by the fact that most of the initial accuracy is due to gain limitation (slope error) and not an offset. Gain adjustment is a one point trim because the output of the device extrapolates to zero at 0°K.

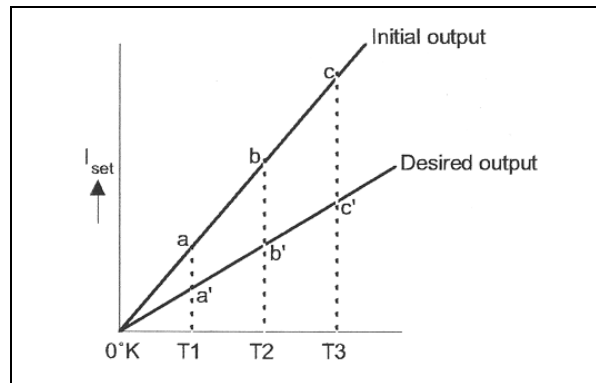

This particularity of the LM134, LM234, LM334 is illustrated in the above diagram. Line abc represents the sensor current before adjustment and line a'b'c' represents the desired output. A gain adjustment provided at T2 will move the output from b to b' and will correct the slope at the same time so that the output at T1 and T3 will be correct. This gain adjustment can be carried out by means of R<sub>set</sub> or the load resistor used in the circuit. After adjustment, the slope error should be less than 1%. A low temperature coefficient for R<sub>set</sub> is necessary to keep this accuracy. A 33ppm/°C temperature drift of R<sub>set</sub> will give an error of 1% on the slope because the resistance follows the same temperature variations as the LM134, LM234, LM334. Three wires are required to isolate R<sub>set</sub> from the LM134, LM234, LM334. Since this solution is not recommended. Metal-film resistors with a drift less than 20ppm/°C are now available. Wirewound resistors can be used when very high stability is required.

TYPICAL APPLICATIONS

Figure 1 : Basic 2-terminal Current Source

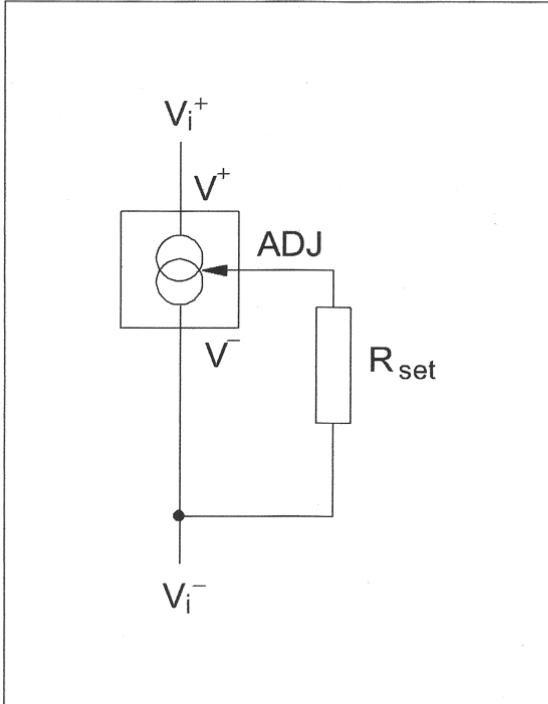

Figure 2 : Alternate Trimming Technique

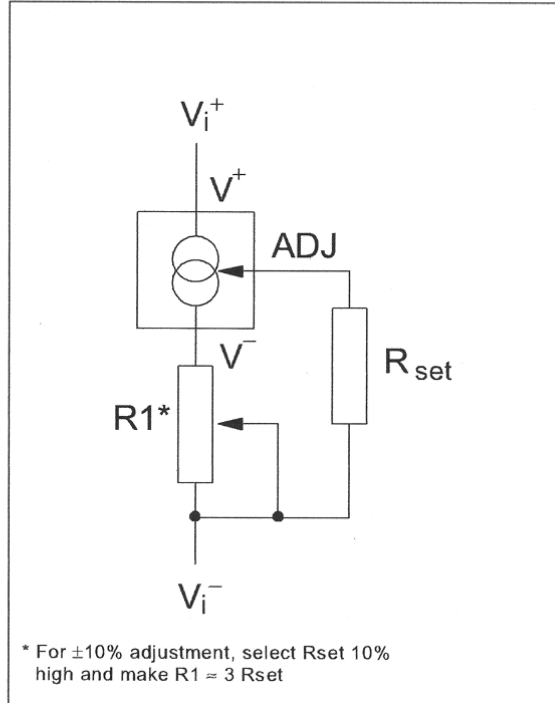

Figure 3 : Terminating Remote Sensor for Voltage Output

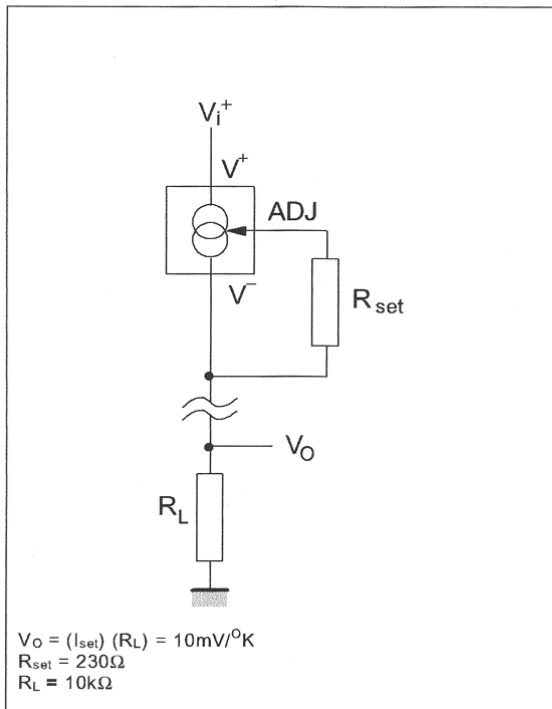

Figure 4 : Zero Temperature Coefficient Current Source

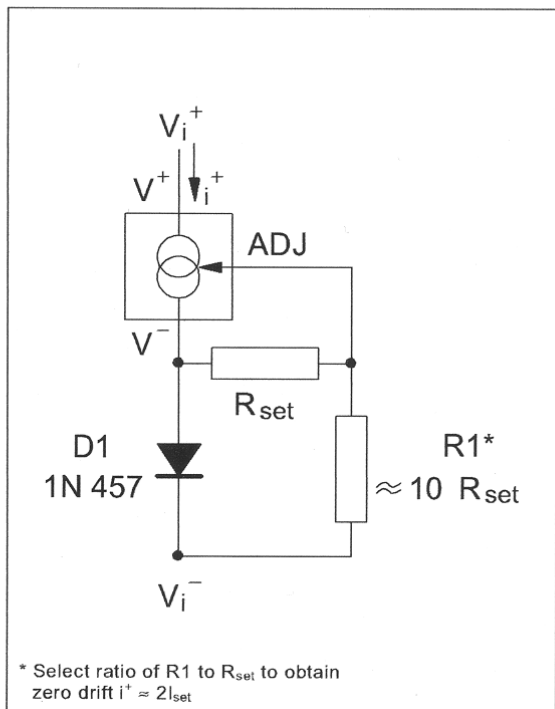

Figure 5 : Low Output Impedance Thermometer

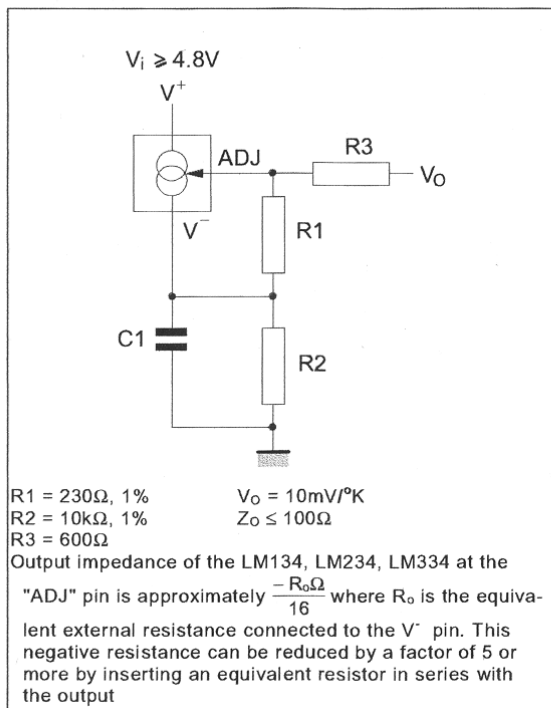

Figure 6 : Low Output Impedance Thermometer

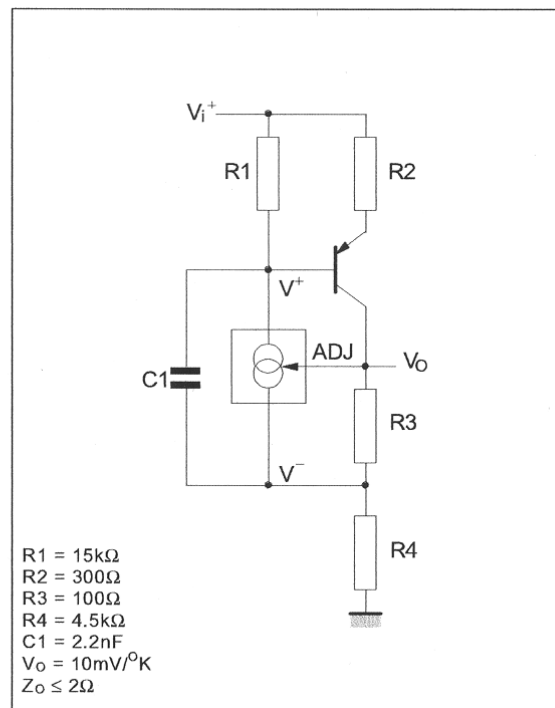

Figure 7 : Micropower Bias

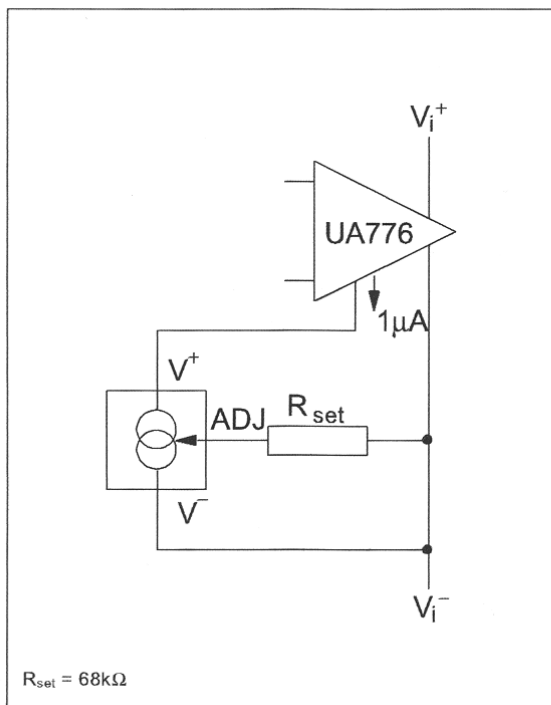

Figure 8 : Low Input Voltage Reference Driver

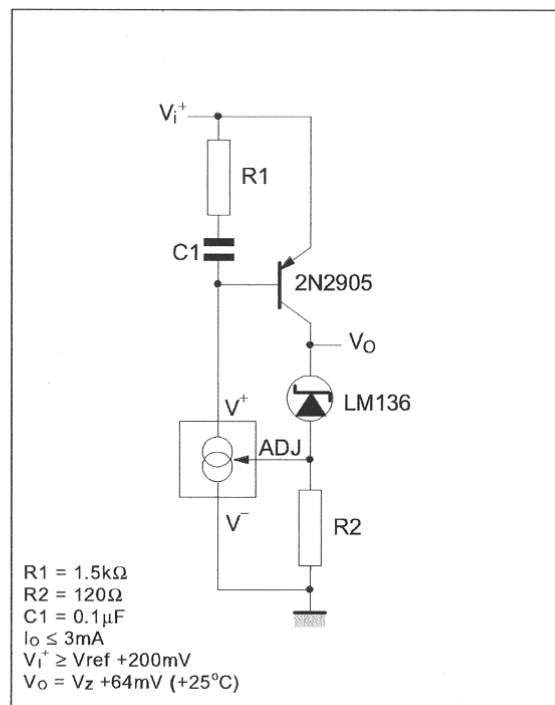

Figure 9 : In-line Current Limiter

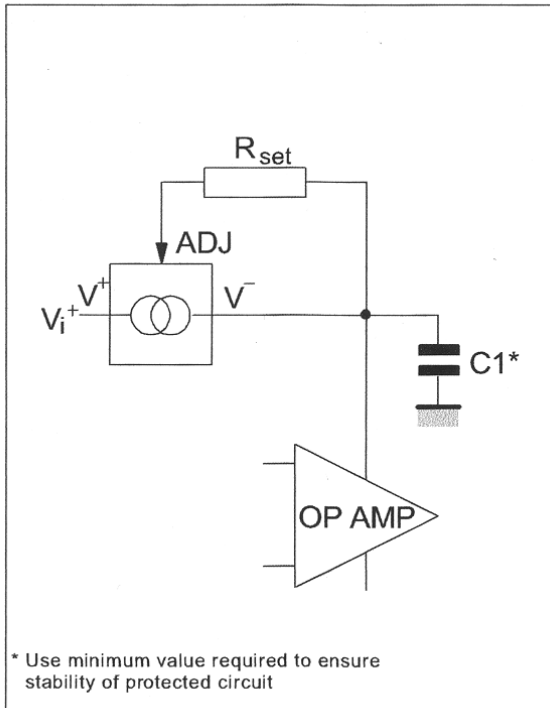
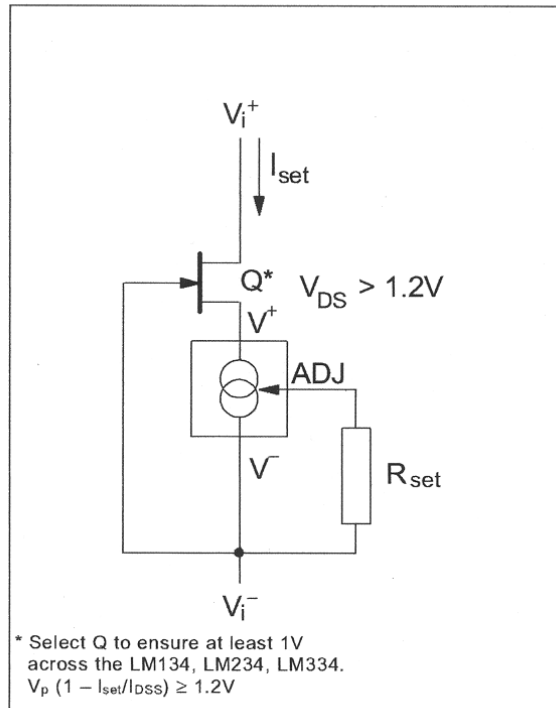

Figure 10 : Fet Cascading for Low Capacitance





PACKAGE MECHANICAL DATA

**SO-8 MECHANICAL DATA**

DIM.	mm.			inch		
	MIN.	TYP	MAX.	MIN.	TYP.	MAX.
A	1.35		1.75	0.053		0.069
A1	0.10		0.25	0.04		0.010
A2	1.10		1.65	0.043		0.065
B	0.33		0.51	0.013		0.020
C	0.19		0.25	0.007		0.010
D	4.80		5.00	0.189		0.197
E	3.80		4.00	0.150		0.157
e		1.27			0.050	
H	5.80		6.20	0.228		0.244
h	0.25		0.50	0.010		0.020
L	0.40		1.27	0.016		0.050
k	$8^\circ$ (max.)					
ddd			0.1			0.04

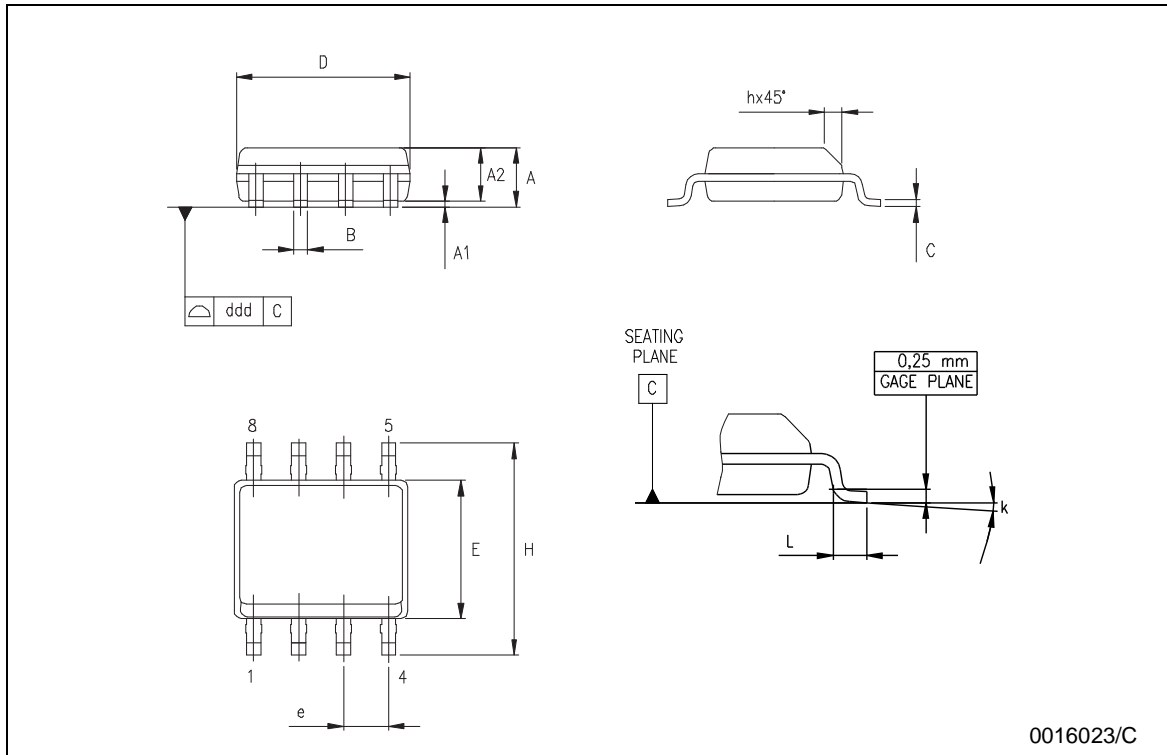

PACKAGE MECHANICAL DATA - TO92 TAPE AMMO PACK & TO92 TAPE & REEL

TO-92 MECHANICAL DATA

DIM.	mm.			inches		
	MIN.	TYP.	MAX.	MIN.	TYP.	MAX.
AL			5.0			0.197
A			5.0			0.197
T			4.0			0.157
d		0.45			0.018	
l1	2.5			0.098		
P	11.7	12.7	13.7	0.461	0.500	0.539
PO	12.4	12.7	13	0.488	0.500	0.512
P2	5.95	6.35	6.75	0.234	0.250	0.266
F1/F2	2.4	2.5	2.8	0.094	0.098	0.110
h	-1	0	1	-0.039	0	0.039
P	-1	0	1	-0.039	0	0.039
W	17.5	18.0	19.0	0.689	0.709	0.748
W0	5.7	6	6.3	0.224	0.236	0.248
W1	8.5	9	9.75	0.335	0.354	0.384
W2			0.5			0.020
H			20			0.787
H0	15.5	16	16.5	0.610	0.630	0.650
H1			25			0.984
DO	3.8	4.0	4.2	0.150	0.157	0.165
L1			11			0.433

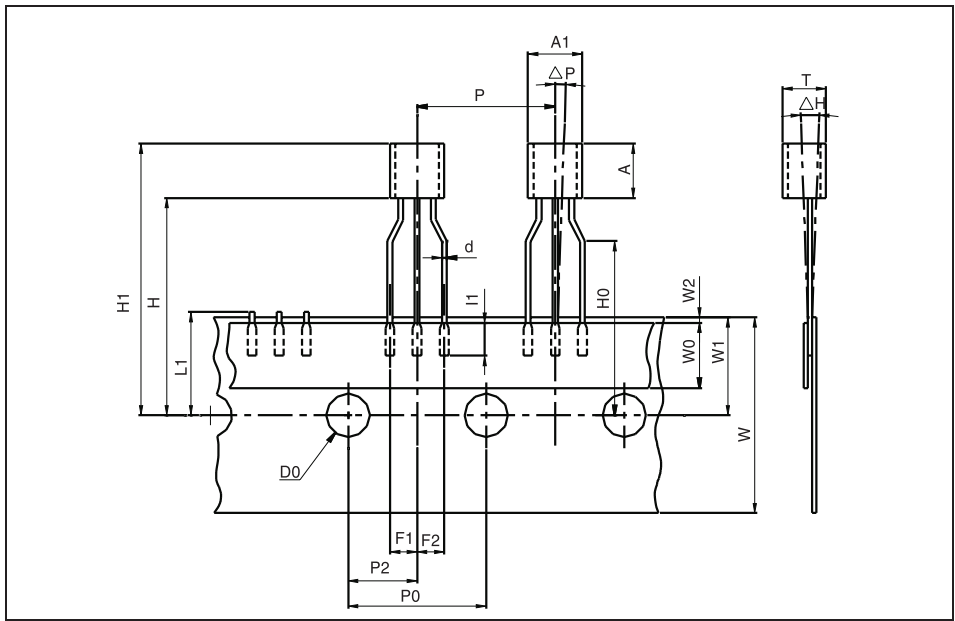

Packing information are available at: <http://www.st.com/stonline/prodpres/packages/stdlin.htm>

PACKAGE MECHANICAL DATA - TO92 BULK

TO-92 MECHANICA DATA						
DIM.	mm.			mils		
	MIN.	TYP.	MAX.	MIN.	TYP.	MAX.
A	4.32		4.95	170.1		194.9
b	0.36		0.51	14.2		20.1
D	4.45		4.95	175.2		194.9
E	3.30		3.94	129.9		155.1
e	2.41		2.67	94.9		105.1
e1	1.14		1.40	44.9		55.1
L	12.7		15.49	500.0		609.8
R	2.16		2.41	85.0		94.9
S1	0.92		1.52	36.2		59.8
W	0.41		0.56	16.1		22.0

0102782/C

Packing information are available at: <http://www.st.com/stonline/prodpres/packages/stdlin.htm>

Information furnished is believed to be accurate and reliable. However, STMicroelectronics assumes no responsibility for the consequences of use of such information nor for any infringement of patents or other rights of third parties which may result from its use. No license is granted by implication or otherwise under any patent or patent rights of STMicroelectronics. Specifications mentioned in this publication are subject to change without notice. This publication supersedes and replaces all information previously supplied. STMicroelectronics products are not authorized for use as critical components in life support devices or systems without express written approval of STMicroelectronics.

The ST logo is a registered trademark of STMicroelectronics

© 2003 STMicroelectronics - All Rights Reserved  
 STMicroelectronics GROUP OF COMPANIES

Australia - Brazil - China - Finland - France - Germany - Hong Kong - India - Italy - Japan - Malaysia - Malta - Morocco  
 Singapore - Spain - Sweden - Switzerland - United Kingdom  
<http://www.st.com>