

LM2452

220V Monolithic Triple Channel 17 MHz DC Coupled CRT DTV Driver

General Description

The LM2452 is a triple channel high voltage DC coupled CRT driver circuit designed for use in DTV applications. The IC contains three high input impedance, wide band amplifiers which directly drive the RGB cathodes of a CRT. Each amplifier has a summing input where the DC level of the output is controlled by a low voltage DC input voltage. Normally the DC input voltage is from a DAC. Each channel has its gain internally set to -54 and can drive CRT capacitive loads as well as resistive loads present in other applications, limited only by the package's power dissipation.

The IC is packaged in a 15-lead TO-247 molded plastic power package designed specifically to meet high voltage spacing requirements. See Thermal Considerations section.

Features

- 17 MHz bandwidth
- 100V black level adjustment range using 0V to 5V input
- Current output for IK feedback systems
- Greater than 130V_{P-P} output swing capability
- 0V to 5V input voltage range
- Stable with 0 pF–20 pF capacitive loads and inductive peaking networks
- Convenient TO-247 staggered thin lead package style

Applications

- DC coupled HDTV applications using the 1080i format as well as standard NTSC and PAL formats.

Connection Diagram

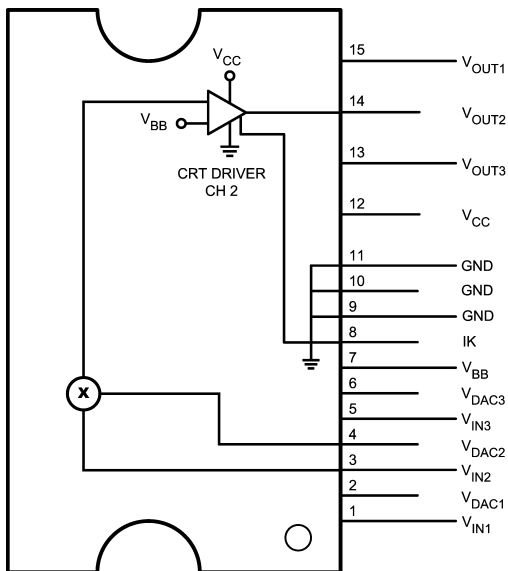

20144501

FIGURE 1. Top View
Order Number LM2452TB
See NS Package Number TB15A

Schematic Diagram

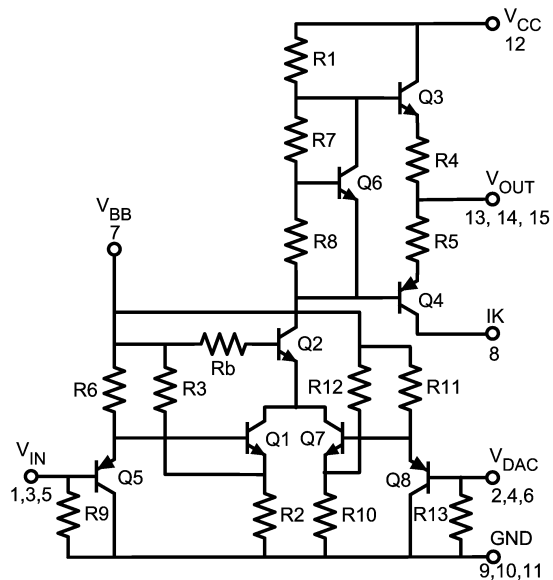

20144502

FIGURE 2. Simplified Schematic Diagram
(One Channel)

Absolute Maximum Ratings (Notes 1,

3)

If Military/Aerospace specified devices are required, please contact the National Semiconductor Sales Office/Distributors for availability and specifications.

Supply Voltage (V_{CC})	+250V
Bias Voltage (V_{BB})	+16V
Input Voltage (V_{IN})	-0.5V to V_{BB} +0.5V
Storage Temperature Range (T_{STG})	-65°C to +150°C
Lead Temperature (Soldering, <10 sec.)	300°C
ESD Tolerance, Human Body Model	2 kV
Machine Model	200V

Junction Temperature

150°C

 θ_{JC} (typ)

3.0°C/W

Operating Ratings (Note 2)

V_{CC}	+100V to +230V
V_{BB}	+7V to +13V
V_{IN}	+0V to +5V
V_{OUT}	+40V to +215V
Case Temperature (15W max power)	100°C

Do not operate the part without a heat sink and thermal grease. Heat sink must have a thermal resistance under 3°C/W. (Note 7)

Electrical Characteristics

(See Figure 3 for Test Circuit). Unless otherwise noted: $V_{CC} = +220V$, $V_{BB} = +12V$, $V_{DAC} = +0.5V$, $C_L = 10$ pF, $T_C = 50^\circ C$. DC Tests: $V_{IN} = +2.7V_{DC}$. AC Tests: Output = 130V_{PP} (60V – 190V) at 1 MHz.

Symbol	Parameter	Conditions	LM2452			Units
			Min	Typ	Max	
I_{CC}	Supply Current	No Input Signal, No Video Input, No Output Load	14	22	30	mA
I_{BB}	Bias Current		20	30	40	mA
$V_{OUT,1}$	DC Output Voltage	No AC Input Signal, $V_{IN} = 2.7V_{DC}$	122	127	132	V_{DC}
$V_{OUT,2}$	DC Output Voltage	No AC Input Signal, $V_{IN} = 1.2V_{DC}$	201	206	211	V_{DC}
$V_{OUT,3}$	DC Output Voltage	No AC Input Signal, $V_{IN} = 1.2V_{DC}$, $V_{DAC} = 1.2V_{DC}$	188	194	200	V_{DC}
$V_{OUT,4}$	DC Output Voltage	No AC Input Signal, $V_{IN} = 1.2V_{DC}$, $V_{DAC} = 3.6V_{DC}$	149	155	161	V_{DC}
A_V	DC Voltage Gain	No AC Input Signal	-51	-54	-57	V/V
A_{DAC}	DAC Input DC Voltage Gain	No AC Input Signal	-23	-26	-29	V/V
ΔA_V	Gain Matching	(Note 4), No AC Input Signal		1.0		dB
LE	Linearity Error	(Notes 4, 5), No AC Input Signal		8		%
t_r	Rise Time	(Note 6), 10% to 90%		20		ns
+OS	Overshoot			13		%
t_f	Fall Time	(Note 6), 90% to 10%		19		ns
-OS	Overshoot	(Note 6)		5		%
BW_L	Large Signal Bandwidth	$V_{OUT AC} = 130 V_{P-P}$, $V_{OUT DC} = 125 V$		18		MHz
BW_M	Medium Signal Bandwidth	$V_{OUT AC} = 100 V_{P-P}$, $V_{OUT DC} = 125 V$		22		MHz
BW_S	Small Signal Bandwidth	$V_{OUT AC} = 60 V_{P-P}$, $V_{OUT DC} = 125 V$		26		MHz
$I_{K_{ERROR}}$	Current Output Error	Output Current = 0 μA to 200 μA	-52	0	52	μA
$\Delta I_{K_{ERROR}}$	Current Output Difference Between Channels	Output Current = 0 μA to 200 μA	0	NA	32	μA

Note 1: Absolute Maximum Ratings indicate limits beyond which damage to the device may occur.

Note 2: Operating ratings indicate conditions for which the device is functional, but do not guarantee specific performance limits. For guaranteed specifications and test conditions, see the Electrical Characteristics. Datasheet min/max specification limits are guaranteed by design, test, or statistical analysis. The guaranteed specifications apply only for the test conditions listed. Some performance characteristics may change when the device is not operated under the listed test conditions.

Note 3: All voltages are measured with respect to GND, unless otherwise specified.

Note 4: Calculated value from Voltage Gain test on each channel.

Note 5: Linearity Error is the variation in DC gain from $V_{IN} = 1.10V$ to $V_{IN} = 4.30V$.

Note 6: Input from signal generator: $t_r, t_f < 10$ ns.

Note 7: Running the 1 MHz to 30 MHz test pattern at 1080i this part will dissipate approximately 15.2 W. This is the commonly accepted test pattern that is representative of the worst case high frequency content for normal television viewing. This is the pattern used to estimate the worst case power dissipation of the LM2452 in its normal application. It is recommended to use a heat sink with a thermal resistance under 3°C/W.

AC Test Circuit

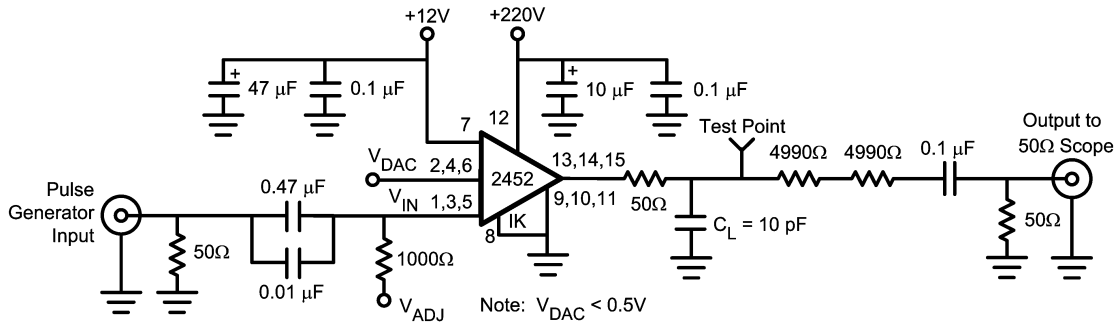

20144503

Note: 10 pF load includes parasitic capacitance.

FIGURE 3. Test Circuit (One Channel)

Figure 3 shows a typical test circuit for evaluation of the LM2452. This circuit is designed to allow testing of the LM2452 in a 50Ω environment without the use of an expensive FET probe. The two 4990Ω resistors form a 400:1 divider with the 50Ω resistor and the oscilloscope probe. A test point is included for easy use of an oscilloscope probe. The compensation capacitor is used to compensate the network to achieve flat frequency response.

Typical Performance Characteristics ($V_{CC} = +220V_{DC}$, $V_{BB} = +12V_{DC}$, $C_L = 10\text{ pF}$, $V_{OUT} = 130V_{PP}$ (60V – 190V), $T_C = 50^\circ\text{C}$, Test Circuit—*Figure 3* unless otherwise specified)

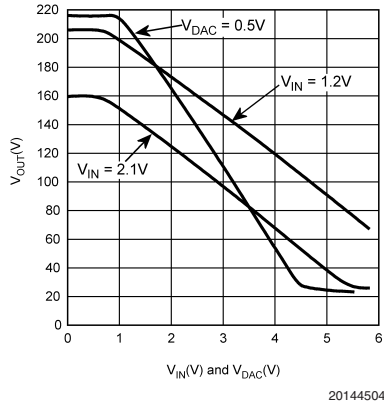

FIGURE 4. V_{OUT} vs V_{IN}

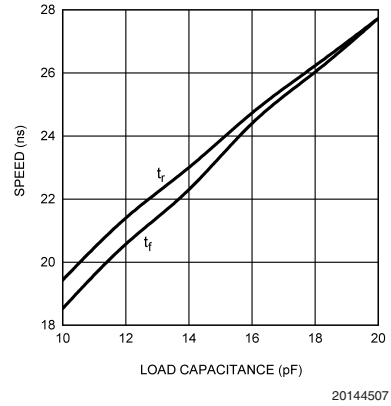

FIGURE 7. Speed vs Load Capacitance

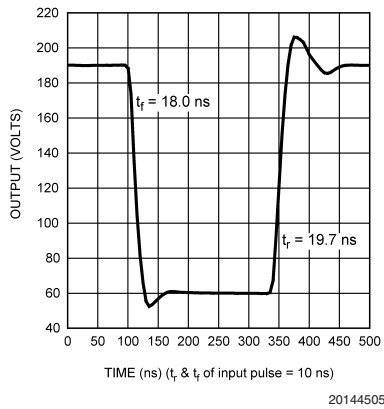

FIGURE 5. LM2452 Pulse Response

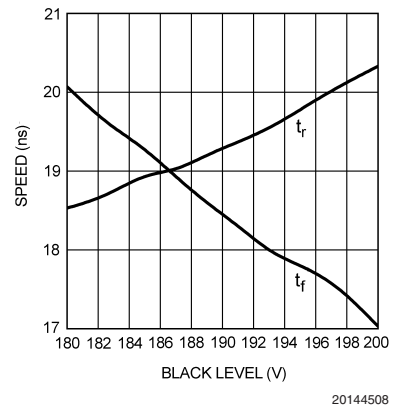

FIGURE 8. Speed vs Offset

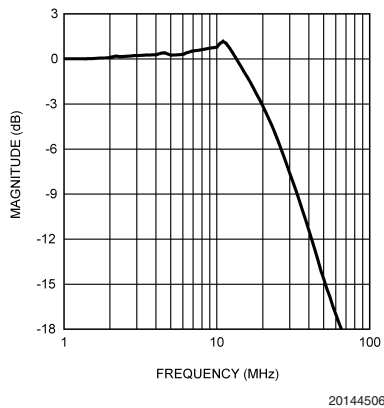

FIGURE 6. Bandwidth

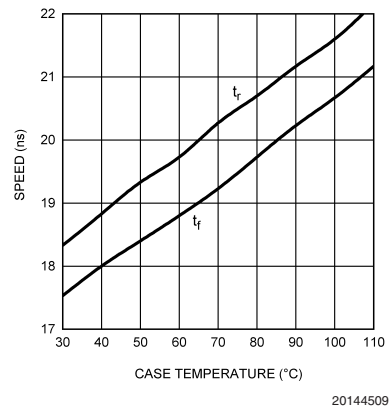
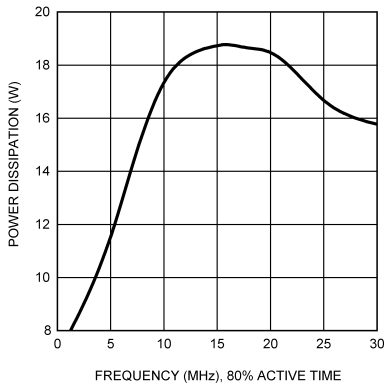

FIGURE 9. Speed vs Case Temperature

Typical Performance Characteristics ($V_{CC} = +220V_{DC}$, $V_{BB} = +12V_{DC}$, $C_L = 10\text{ pF}$, $V_{OUT} = 130V_{PP}$ (60V – 190V), $T_C = 50^\circ\text{C}$, Test Circuit—*Figure 3* unless otherwise specified)



20144510

FIGURE 10. Power Dissipation vs Frequency

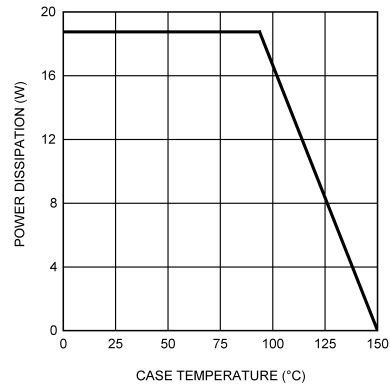

20144511

FIGURE 11. Safe Operating Area

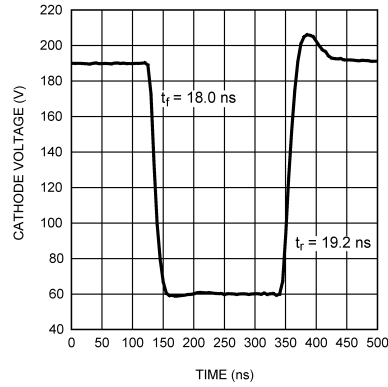

20144512

FIGURE 12. LM2452 Cathode Response

Theory of Operation

The LM2452 is a high voltage monolithic three channel CRT driver suitable for DTV applications. The LM2452 operates with 220V and 12V power supplies. The part is housed in a 15-lead TO-247 molded plastic power package with thin leads for improved metal-to-metal spacing.

The circuit diagram of the LM2452 is shown in *Figure 2*. The PNP emitter follower, Q5, provides input buffering. Q1 and Q2 form a fixed gain cascode amplifier with resistors R1 and R2 setting the gain at -54 . An additional cascode amplifier is formed by Q7 and Q2. Gain of this stage is set to -26 by resistors R1 and R10. Q8 provides the input buffering for this input. Q2 now becomes the summing point for both V_{IN} and V_{DAC} . Emitter followers Q3 and Q4 isolate the high output impedance of the cascode stage from the capacitance of the CRT cathode, which decreases the sensitivity of the device to load capacitance. Q6 provides biasing to the output emitter follower stage to reduce crossover distortion at low signal levels.

Figure 3 shows a typical test circuit for evaluation of the LM2452. This circuit is designed to allow testing of the LM2452 in a 50 Ω environment without the use of an expensive FET probe. In this test circuit, the two 4.99 k Ω resistors form a 400:1 wideband, low capacitance probe when connected to a 50 Ω coaxial cable and a 50 Ω load (such as a 50 Ω oscilloscope input). The input signal from the generator is AC coupled to the video inputs of the LM2452.

Application Hints

INTRODUCTION

National Semiconductor (NSC) is committed to provide application information that assists our customers in obtaining the best performance possible from our products. The following information is provided in order to support this commitment. The reader should be aware that the optimization of performance was done using a specific printed circuit board designed at NSC. Variations in performance can be realized due to physical changes in the printed circuit board and the application. Therefore, the designer should know that component value changes may be required in order to optimize performance in a given application. The values shown in this document can be used as a starting point for evaluation purposes. When working with high bandwidth circuits, good layout practices are also critical to achieving maximum performance.

IMPORTANT INFORMATION

The LM2452 performance is targeted for the HDTV market. The application circuits shown in this document to optimize performance and to protect against damage from CRT arc over are designed specifically for the LM2452. If another member of the LM245X family is used, please refer to its datasheet.

POWER SUPPLY BYPASS

Since the LM2452 is a wide bandwidth amplifier, proper power supply bypassing is critical for optimum performance. Improper power supply bypassing can result in large overshoot, ringing or oscillation. 0.1 μ F capacitors should be connected from the supply pins, V_{CC} and V_{BB} , to ground, as close to the LM2452 as is practical. Additionally, a 22 μ F or larger electrolytic capacitor should be connected from both supply pins to ground reasonably close to the LM2452.

ARC PROTECTION

During normal CRT operation, internal arcing may occasionally occur. This fast, high voltage, high-energy pulse can damage the LM2452 output stage. The application circuit shown in *Figure 13* is designed to help clamp the voltage at the output of the LM2452 to a safe level. The clamp diodes, D1 and D2, should have a fast transient response, high peak current rating, low series impedance and low shunt capacitance. 1SS83 or equivalent diodes are recommended. D1 and D2 should have short, low impedance connections to V_{CC} and ground respectively. The cathode of D1 should be located very close to a separately decoupled bypass capacitor (C3 in *Figure 13*). The ground connection of D2 and the decoupling capacitor should be very close to the LM2452 ground. This will significantly reduce the high frequency voltage transients that the LM2452 would be subjected to during an arc over condition. Resistor R2 limits the arc over current that is seen by the diodes while R1 limits the current into the LM2452 as well as the voltage stress at the outputs of the device. R2 should be a $\frac{1}{2}$ W solid carbon type resistor. R1 can be a $\frac{1}{4}$ W metal or carbon film type resistor. Having large value resistors for R1 and R2 would be desirable, but this has the effect of increasing rise and fall times. Inductor L1 is critical to reduce the initial high frequency voltage levels that the LM2452 would be subjected to before the clamp diodes have a chance to become activated. The inductor will not only help protect the device but it will also help minimize rise and fall times as well as minimize EMI. For proper arc protection, it is important to not omit any of the arc protection components shown in *Figure 13*.

Arc protection includes the V_{CC} and V_{BB} power supply inputs. Ferrite beads shown as FB1 and FB2 in *Figure 14* must be included for proper arc protection of the power supply inputs. These ferrite beads do need to be located close to the bypass capacitors that were covered in the previous section, "Power Supply Bypass".

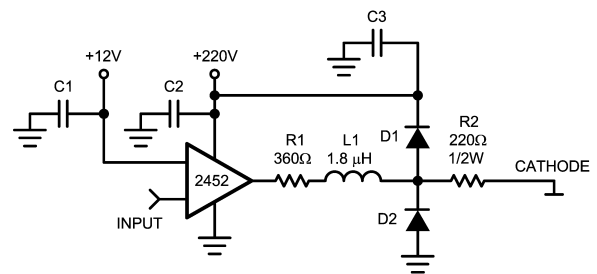

20144513

FIGURE 13. One Channel of the LM2452 with the Recommended Application Circuit

EFFECT OF LOAD CAPACITANCE

Figure 7 shows the effect of increased load capacitance on the speed of the device. This demonstrates the importance of knowing the load capacitance in the application. Increasing the load capacitance from 10 pF to 20 pF adds about 9 ns to the rise and fall times. It is very important to keep the board capacitance as low as possible to maximize the speed of the driver.

EFFECT OF OFFSET

Figure 8 shows the variation in rise and fall times when the black level of the device is varied from 180V to 200V_{DC}. The rise time increases only about 2ns as the offset is increased

Application Hints (Continued)

in voltage and the fall time decreases only about 3 ns with the same offset adjustment. Offset voltage variation has a minimal affect on the rise and fall times of the driver if the saturation area is avoided.

THERMAL CONSIDERATIONS

Figure 9 shows the performance of the LM2452 in the test circuit shown in *Figure 3* as a function of case temperature. The figure shows that the rise and fall times of the LM2452 increases by under 4 ns as the case temperature increases from 30°C to 110°C. Please note that this part should not be operated with a case temperature over 100°C. The response above 100°C is shown only for reference.

Figure 10 shows the maximum power dissipation of the LM2452 vs. Frequency when all three channels of the device are driving into a 10 pF load with a 130V_{P-P} alternating one pixel on, one pixel off. Note that the frequency given in *Figure 10* is half of the pixel frequency. The graph assumes an 80% active time (device operating at the specified frequency), which is typical in a TV application. The other 20% of the time the device is assumed to be sitting at the black level (190V in this case). A TV picture will not have frequency content over the whole picture exceeding 15 MHz. It is important to establish the worst case condition under normal viewing to give a realistic worst-case power dissipation for the LM2452. One test is a 1 to 30 MHz sine wave sweep over the active line. This would give a slightly lower power than taking the average of the power between 1 and 30 MHz. This average is 15.2 W. A sine wave will dissipate slightly less power, probably about an even 15W of power dissipation. All of this information is critical for the designer to establish the heat sink requirement for his application. The designer should note that if the load capacitance is increased the AC component of the total power dissipation will also increase.

The LM2452 case temperature must be maintained below 100°C given the maximum power dissipation estimate of 15W. If the maximum expected ambient temperature is 60°C and the maximum power dissipation is 15W then a maximum heat sink thermal resistance can be calculated:

$$R_{TH} = \frac{100^{\circ}\text{C} - 60^{\circ}\text{C}}{15\text{W}} = 2.7^{\circ}\text{C/W}$$

This example assumes a capacitive load of 10 pF and no resistive load. If the maximum ambient temperature is 50°C, then the heat sink thermal resistance can increase to 3.3°C/W. The designer should note that if the load capacitance is increased the AC component of the total power dissipation will also increase.

OPTIMIZING TRANSIENT RESPONSE

Referring to *Figure 13*, there are three components (R1, R2 and L1) that can be adjusted to optimize the transient response of the application circuit. Increasing the values of R1 and R2 will slow the circuit down while decreasing overshoot. Increasing the value of L1 will speed up the circuit as well as increase overshoot. It is very important to use inductors with very high self-resonant frequencies, preferably above 300 MHz. Ferrite core inductors from J.W. Miller Magnetics (part # 78FR--K) were used for optimizing the performance of the device in the NSC application board. The values shown in *Figure 13* can be used as a good starting point for the evaluation of the LM2452. Using a variable

resistor for R1 will simplify finding the value needed for optimum performance in a given application. Once the optimum value is determined the variable resistor can be replaced with a fixed value. Due to arc over considerations it is recommended that the values shown in *Figure 13* not be changed by a large amount.

Figure 12 shows the typical cathode pulse response with an output swing of 130V_{P-P} inside a modified production TV set using the LM1237 pre-amp.

PC BOARD LAYOUT CONSIDERATIONS

For optimum performance, an adequate ground plane, isolation between channels, good supply bypassing and minimizing unwanted feedback are necessary. Also, the length of the signal traces from the signal inputs to the LM2452 and from the LM2452 to the CRT cathode should be as short as possible. The following references are recommended:

Ott, Henry W., "Noise Reduction Techniques in Electronic Systems", John Wiley & Sons, New York, 1976.

"Video Amplifier Design for Computer Monitors", National Semiconductor Application Note 1013.

Pease, Robert A., "Troubleshooting Analog Circuits", Butterworth-Heinemann, 1991.

Because of its high small signal bandwidth, the part may oscillate in a TV if feedback occurs around the video channel through the chassis wiring. To prevent this, leads to the video amplifier input circuit should be shielded, and input circuit wiring should be spaced as far as possible from output circuit wiring.

TYPICAL APPLICATION

A typical application of the LM2452 is shown in *Figure 14*. Used in conjunction with a pre-amp with a 1.2V black level output no buffer transistors are required to obtain the correct black level at the cathodes. If the pre-amp has a black level closer to 2V, then an NPN transistor should be used to drop the video black level voltage closer to 1.2V. When using only one NPN transistor as an emitter follower, a jumper needs to be added in each channel. In the red channel a jumper needs to be added between C7 and R25. With just one transistor neither of these components would be installed.

In addition to the video inputs are the DAC inputs. These inputs are used to vary the LM2452 output black level by a DAC. in the past when a driver was used with a CMOS AVP there was not enough range on the video output to vary the black level. A clamp circuit had to be used in conjunction with the AVP and the driver. The DAC inputs of the LM2452 are driven in the same way the clamp circuit had been driven, eliminating the need for a clamp circuit. *Figure 4* shows the variation in the black level as the DAC input voltage is changed. This is shown for both V_{IN} = 1.2V and V_{IN} = 2.1V. The neck board in *Figure 14* has two transistors in each channel enabling this board to work with pre-amps with a black level output as high as 2.5V. Each transistor stage has a gain of -1. This setup still gives the two diode drop at the driver input; however, now additional peaking can be done on the video signal before reaching the driver inputs. Some popular AVPs do have a black level of 2.5V. For lower black levels either one or both transistors would not be used.

It is important that the TV designer use component values for the driver output stage close to the values shown in *Figure 14*. These values have been selected to protect the LM2452 from arc over. Diodes D1, D8, D9, and D13-D15 must also be used for proper arc over protection. The NSC demonstration board can be used to evaluate the LM2452 in a TV.

Application Hints (Continued)

NSC DEMONSTRATION BOARD

Figure 15 shows the routing and component placement on the NSC LM2452 demonstration board. This board provides a good example of a layout that can be used as a guide for future layouts. Note the location of the following components:

- C26— V_{CC} bypass capacitor, located very close to pin 12 and ground pins
- C27— V_{BB} bypass capacitor, located close to pin 7 and ground
- C28, C30, C33— V_{CC} bypass capacitors, near LM2452 and V_{CC} clamp diodes. Very important for arc protection.

The routing of the LM2452 outputs to the CRT is very critical to achieving optimum performance. Figure 16 shows the routing and component placement from pin 13 (V_{OUT3}) of the LM2452 to the blue cathode. Note that the components are placed so that they almost line up from the output pin of the LM2452 to the blue cathode pin of the CRT connector. This is done to minimize the length of the video path between these two components. Note also that D1, D8 and R36 are placed to minimize the size of the video nodes that they are attached to. This minimizes parasitic capacitance in the video path and also enhances the effectiveness of the protection diodes. The anode of protection diode D1 is connected directly to a section of the ground plane that has a short and direct path to the heater ground and the LM2452 ground pins. The cathode of D8 is connected to V_{CC} very close to decoupling capacitor C28 which is connected to the same area of the ground trace as D1. The diode placement and routing is very important for minimizing the voltage stress on the LM2452 during an arc over event.

This demonstration board uses large PCB holes to accommodate socket pins, which function to allow for multiple insertions of the LM2452 in a convenient manner. To benefit from the enhanced LM2452 package with thin leads, the device should be secured in small PCB holes to optimize the metal-to-metal spacing between the leads.

CURRENT OUTPUT FOR IK FEEDBACK SYSTEMS

The LM2452 can be used in DTV applications that use an IK feedback system. Figure 14 shows an example of an interface circuit used to feed back the IK output of LM2452 to a preamplifier with an ac coupled IK input.

This feedback system consists of the preamp, LM2452, and interface circuit, forming a closed loop to automatically adjust the black level of the drive signals to the cutoff point of the RGB cathodes. Following is a description of the interface circuit operation used for AVPs that have a voltage input for their IK sense input.

The output at pin 8 of the LM2452 is filtered of high frequency noise by C14. D7 is used to limit the peak voltage at pin 8. Without this clamp diode the voltage would easily exceed 12V during active video when the cathode currents are much greater than the small currents being detected during vertical blanking. Exceeding 12V could damage Q1 and result in improper operation of the driver.

R35 is essential to convert the IK current to voltage. Choosing the value of R35 sets the gain of the feedback voltage, and consequently, the operating point of the tube. Once a stable operating point is established, this point can be fine-tuned using the adjustment range of the feedback system or standard preamp controls. Changing the value of R35 will change the cutoff voltage at the cathode. A smaller value of R35 requires more IK current to maintain the feedback loop. The cutoff voltage set at the cathode will be lower to adjust to the higher IK current. This additional current must come from the cathode; therefore, the cathode voltage is set lower to meet higher current requirement. A higher value of R35 will do the opposite, raising the cathode voltage because less IK current is needed to maintain the same voltage at R35.

The emitter follower, Q7, isolates R35 from the input impedance of the preamp. R21 and R39 bias the emitter of Q7 to limit the maximum voltage to the preamp. These resistor values should be chosen to limit the maximum voltage at the emitter and protect the preamp from any large voltages that would otherwise occur during active video. C9 is used to AC couple the IK signal to the preamp. The advantage of AC coupling is that any DC component (leakage current from the driver) of the IK signal is not detected by the IK sense input of the preamp.

Some AVPs do have a direct current input for their IK sense input. For interfacing to these AVPs the only components to be used in the IK sense section are D7 and R41. To complete the signal path a jumper must be used to replace R34, C9 and the base-emitter junction of Q7. C14 can still be used for high frequency filtering.

Application Hints (Continued)

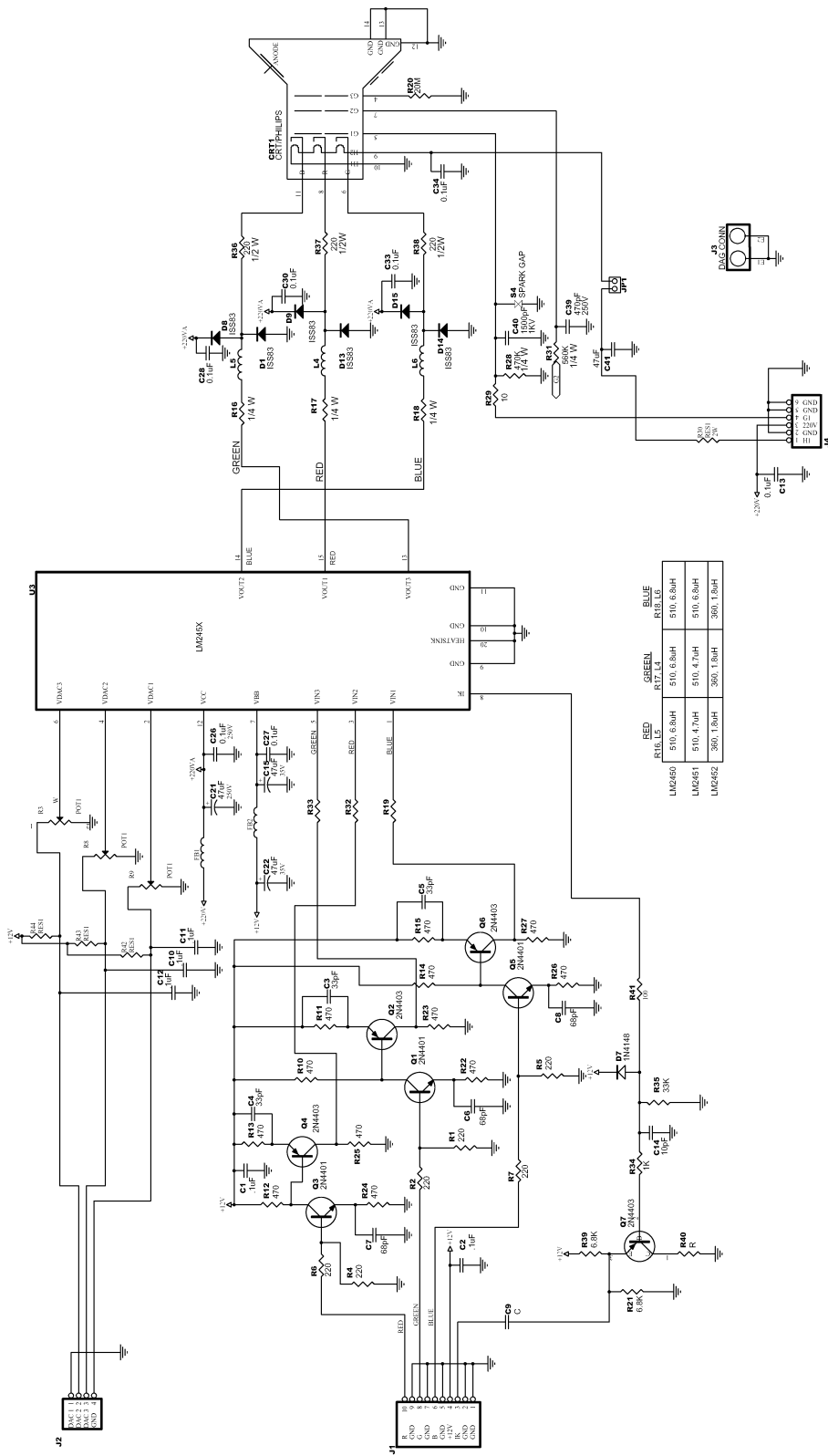

	RED	GREEN	BLUE
R18, L5	R17, L4	R18, L5	
LM2450	510, 6.8μH	510, 6.8μH	510, 6.8μH
LM2451	510, 4.7μH	390, 1.8μH	390, 1.8μH
LM2452	390, 1.8μH	390, 1.8μH	390, 1.8μH

FIGURE 14. LM2452 DTV Applications Circuit

20144514

Application Hints (Continued)

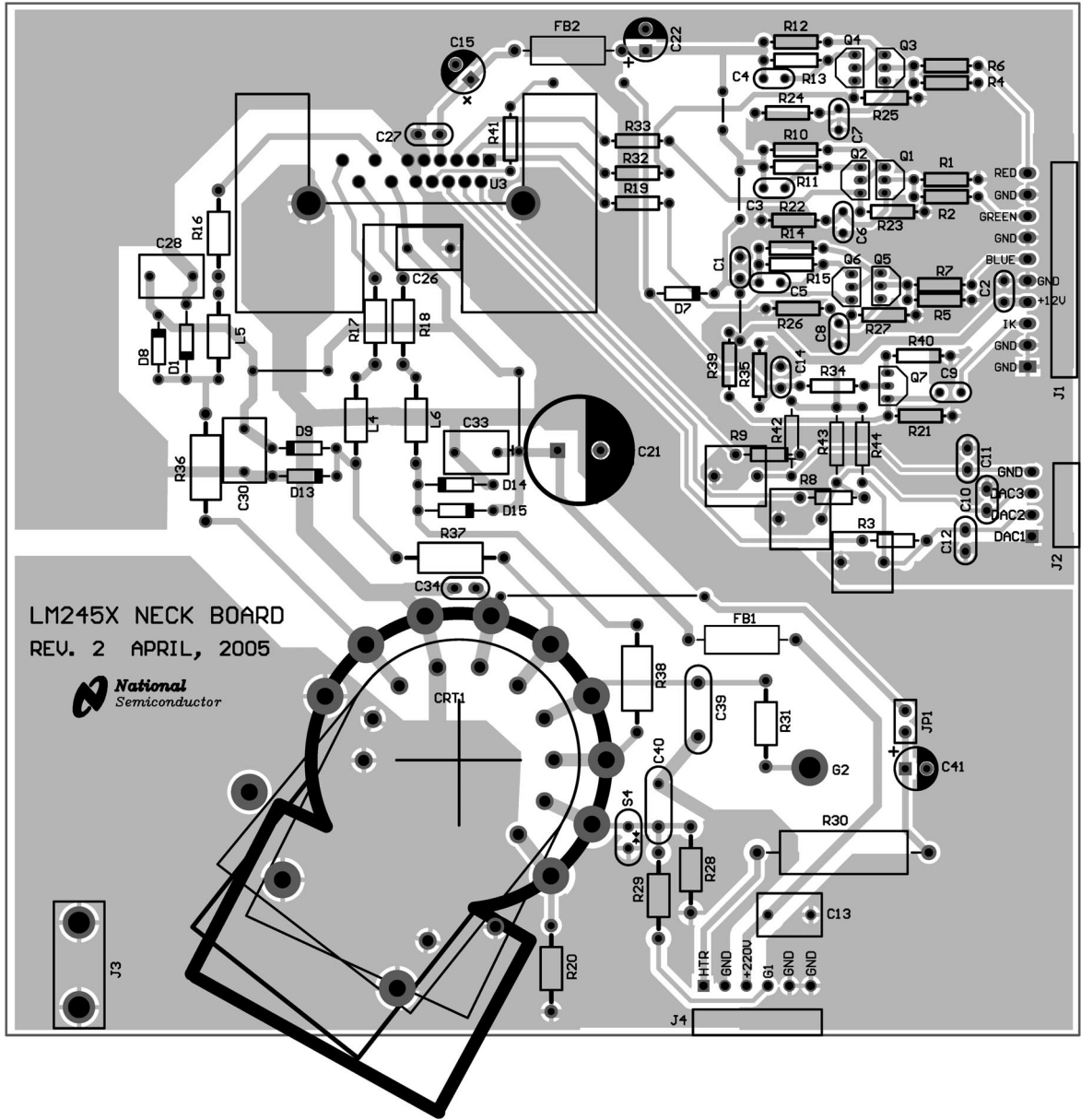

20144516

FIGURE 15. LM2452 DTV Demonstration Board Layout

Application Hints (Continued)

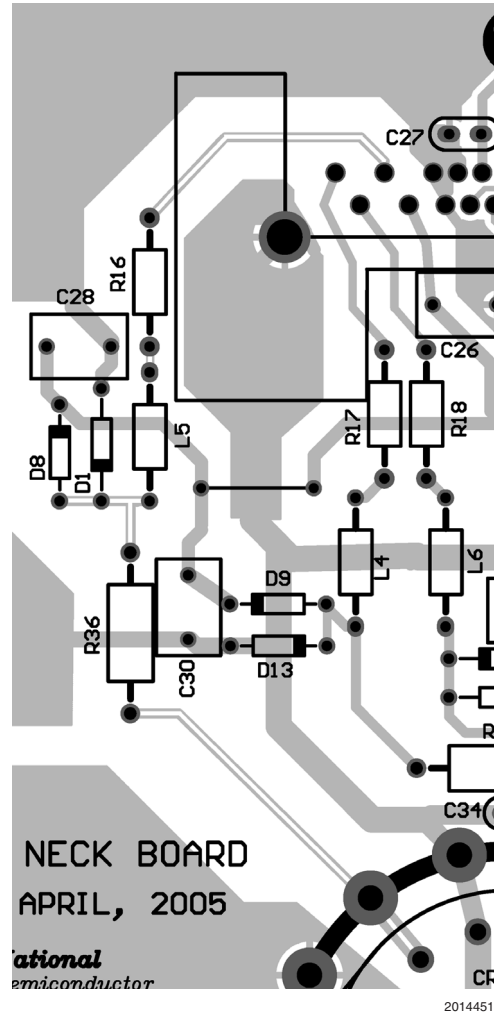
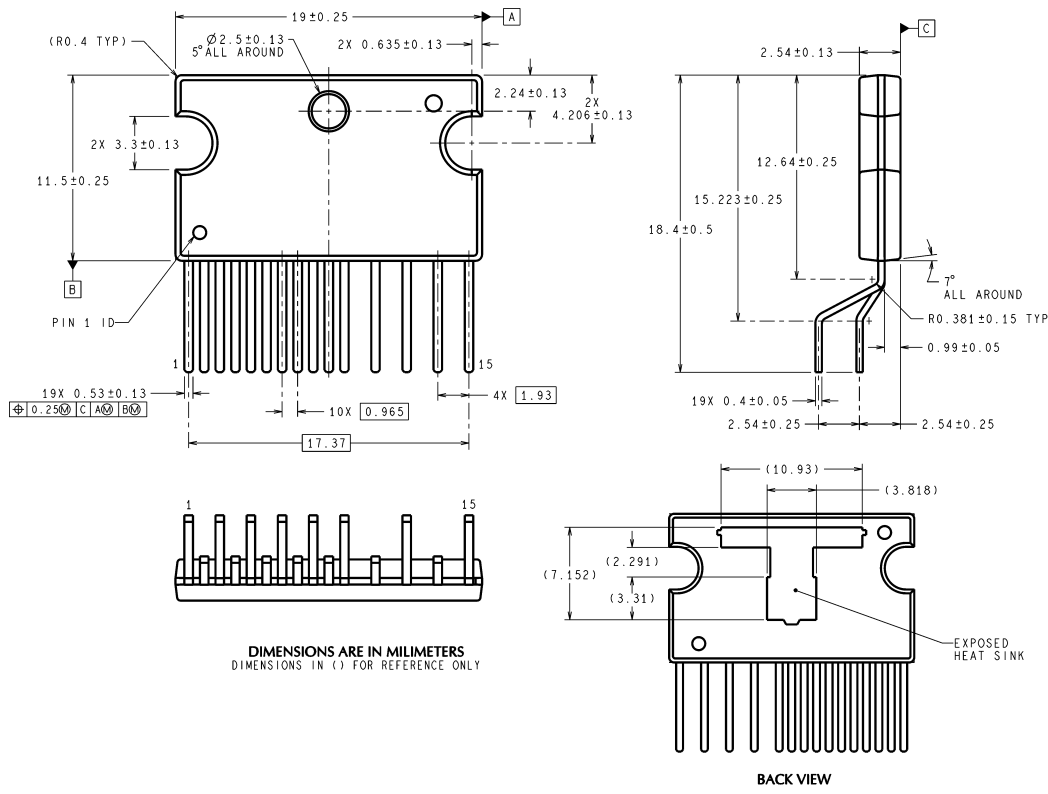

FIGURE 16. Trace Routing and Component Placement for Blue Channel Output

Physical Dimensions inches (millimeters) unless otherwise noted



NOTE: Available only with lead free plating

NS Package Number TB15A
Order Number LM2452TB

National does not assume any responsibility for use of any circuitry described, no circuit patent licenses are implied and National reserves the right at any time without notice to change said circuitry and specifications.

For the most current product information visit us at www.national.com.

LIFE SUPPORT POLICY

NATIONAL'S PRODUCTS ARE NOT AUTHORIZED FOR USE AS CRITICAL COMPONENTS IN LIFE SUPPORT DEVICES OR SYSTEMS WITHOUT THE EXPRESS WRITTEN APPROVAL OF THE PRESIDENT AND GENERAL COUNSEL OF NATIONAL SEMICONDUCTOR CORPORATION. As used herein:

1. Life support devices or systems are devices or systems which, (a) are intended for surgical implant into the body, or (b) support or sustain life, and whose failure to perform when properly used in accordance with instructions for use provided in the labeling, can be reasonably expected to result in a significant injury to the user.
2. A critical component is any component of a life support device or system whose failure to perform can be reasonably expected to cause the failure of the life support device or system, or to affect its safety or effectiveness.

BANNED SUBSTANCE COMPLIANCE

National Semiconductor manufactures products and uses packing materials that meet the provisions of the Customer Products Stewardship Specification (CSP-9-111C2) and the Banned Substances and Materials of Interest Specification (CSP-9-111S2) and contain no "Banned Substances" as defined in CSP-9-111S2.

Leadfree products are RoHS compliant.



National Semiconductor
Americas Customer Support Center
Email: new.feedback@nsc.com
Tel: 1-800-272-9959

National Semiconductor
Europe Customer Support Center
Fax: +49 (0) 180-530 85 86
Email: europa.support@nsc.com
Deutsch Tel: +49 (0) 69 9508 6208
English Tel: +44 (0) 870 24 0 2171
Français Tel: +33 (0) 1 41 91 8790

National Semiconductor
Asia Pacific Customer Support Center
Email: ap.support@nsc.com

National Semiconductor
Japan Customer Support Center
Fax: 81-3-5639-7507
Email: jpn.feedback@nsc.com
Tel: 81-3-5639-7560

www.national.com