

## LM2796

# Dual-Display White LED Driver with 3/2x Switched Capacitor Boost

### General Description

The LM2796 is a charge-pump based white-LED driver that is ideal for mobile phone display backlighting. It can drive up to 7 LEDs in parallel with up to 20mA through each LED. Regulated internal current sources deliver excellent current and brightness matching in all LEDs. The LED-driver current sources are split into two independently controlled groups. The primary group (4 LEDs) can be used to backlight the main phone display. The second group (3 LEDs) can be used to backlight a secondary display or to provide other lighting features (keypad LEDs, for example). Brightness of the two groups can be adjusted independently with pulse-width modulated (PWM) digital signals.

The LM2796 works off an extended Li-Ion input voltage range (2.7V to 5.5V). Voltage boost is achieved with a high-efficiency 3/2x-gain charge pump.

The LM2796 is available in National's chip-scale 18-bump micro SMD package.

### Features

- Drives up to 7 LEDs with up to 20mA each
- LEDs controlled in 2 Distinct Groups, for Backlighting 2 Displays (main LCD and sub-LCD)
- Excellent Current and Brightness Matching
- High-Efficiency 3/2x Charge Pump
- Extended Li-Ion Input: 2.7V to 5.5V
- PWM Brightness Control: 100Hz - 1kHz
- 18-bump Thin Micro SMD Package: (2.1mm x 2.4mm x 0.6mm)

### Applications

- Mobile Phone Display Lighting
- Mobile Phone Keypad Lighting
- PDAs
- General LED Lighting

### Typical Application Circuit

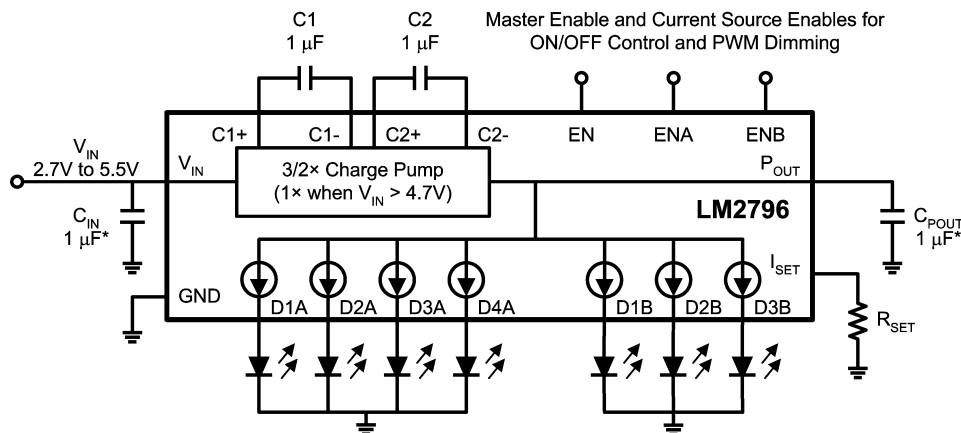

Capacitors: TDK C1608X5R1A105K, or equivalent

\*If total LED current is above 80 mA, as can occur when all 7 outputs are ON simultaneously, 2.2 µF capacitors are recommended for  $C_{IN}$  and  $C_{P_{OUT}}$ .

20093801

## Connection Diagram

### 18-Bump Thin Micro SMD Package, Large Bump NS Package Number TLA18

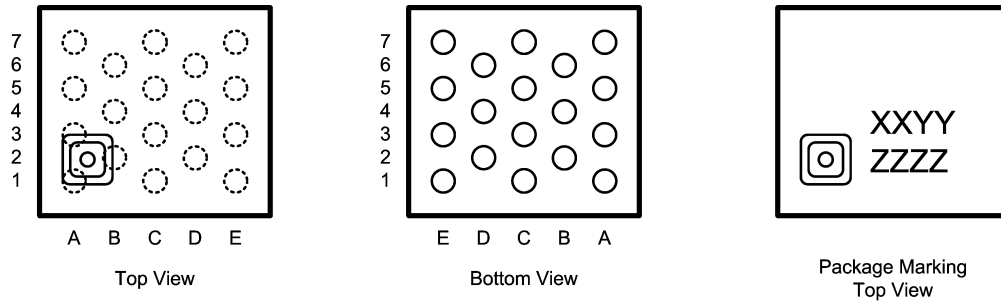

**Note:** The actual physical placement of the package marking will vary from part to part. The package marking "XX" designates the date code. "YY" is a NSC internal code for die traceability. Both will vary considerably. "ZZZZ" (placeholder until actual package ID is determined) identifies the device (part number, option, etc.).

20093802

## Pin Description

Pin #s	Pin Names	Pin Descriptions
C1	$V_{IN}$	Input voltage. Input range: 2.7V to 5.5V.
D2	GND	Ground
A3	$P_{OUT}$	Charge pump output. Approximately $1.5 \times V_{IN}$
A1, B2, A5, E1	C1+, C1-, C2+, C2-	Flying capacitor connections.
A7	EN	Enable pin. Logic input. High = normal operation, Low = shutdown (charge pump and all current sources OFF).
D6, E5, D4, E3	D1A, D2A, D3A, D4A	LED Outputs - Group A
C5, B4, C3	D1B, D2B, D3B	LED Outputs - Group B
B6	EN-A	Enable for Group-A LEDs (current outputs). Logic input. High = Group-A LEDs ON. Low = Group A LEDs OFF. Pulsing this pin with a PWM signal (100Hz-1kHz) can be used to dim LEDs.
E7	EN-B	Enable for Group-B LEDs (current outputs). Logic input. High = Group-B LEDs ON. Low = Group B LEDs OFF. Pulsing this pin with a PWM signal (100Hz-1kHz) can be used to dim LEDs.
C7	$I_{SET}$	Placing a resistor ( $R_{SET}$ ) between this pin and GND sets the LED current for all LEDs. LED Current = $100 \times (1.25V \div R_{SET})$ .

## Ordering Information

Order Information	Package	Supplied As
LM2796TL	TLA18 Micro SMD	250 Units, Tape & Reel
LM2796TLX		3000 Units, Tape & Reel

**Absolute Maximum Ratings** (Notes 1, 2)

If Military/Aerospace specified devices are required, please contact the National Semiconductor Sales Office/Distributors for availability and specifications.

$V_{IN}$ pin voltage	-0.3V to 7.1V
EN, ENA, ENB pin voltages	-0.3V to ( $V_{IN}+0.3V$ ) w/ 5.6V max
Continuous Power Dissipation (Note 3)	Internally Limited
Junction Temperature ( $T_{J-MAX}$ )	150°C
Storage Temperature Range	-65°C to +150°C
Maximum Lead Temperature (Soldering, 10 sec.)	265°C
ESD Rating (Note 4) Human Body Model:	2.0kV
Machine Model	200V

**Operating Rating** (Notes 1, 2)

Input Voltage Range	2.7V to 5.5V
Junction Temperature ( $T_J$ ) Range	-30°C to +125°C
Ambient Temperature ( $T_A$ ) Range (Note 5)	-30°C to +85°C

**Thermal Properties**

Junction-to-Ambient Thermal Resistance ( $\theta_{JA}$ ), (Note 6)	100°C/W
--	---------

**Electrical Characteristics** (Notes 2, 7)

Limits in standard typeface and typical values apply for  $T_J = 25^\circ\text{C}$ . Limits in **boldface** type apply over the full operating junction temperature range ( $-30^\circ\text{C} \leq T_J \leq +85^\circ\text{C}$ ). Unless otherwise specified:  $V_{IN} = 3.6\text{V}$ ;  $V_{DXX} = 3.6\text{V}$ ;  $V(EN) = 2.0\text{V}$ ; Group A and Group B LEDs not ON simultaneously (ENA =  $V_{IN}$  and ENB = GND, or ENA = GND and ENB =  $V_{IN}$ );  $R_{SET} = 8.35\text{k}\Omega$ ;  $C_{IN}$ ,  $C_1$ ,  $C_2$ , and  $C_{POUT} = 1\mu\text{F}$ . (Note 8)

Symbol	Parameter	Condition	Min	Typ	Max	Units
$I_{DXX}$	Output Current Regulation	$3.0\text{V} \leq V_{IN} \leq 4.2\text{V}$ , and $V_{IN} = 5.5\text{V}$ $2.5\text{V} \leq V_{DXX} \leq 3.8\text{V}$ ; $R_{SET} = 8.35\text{k}\Omega$	<b>13.8</b> <b>(-8%)</b>	15	<b>16.2</b> <b>(+8%)</b>	<b>mA</b> <b>(%)</b>
		$3.0\text{V} \leq V_{IN} \leq 5.5\text{V}$ ; $2.5\text{V} \leq V_{DXX} \leq 3.6\text{V}$ ; $R_{SET} = 6.25\text{k}\Omega$		20		<b>mA</b>
		$3.0\text{V} \leq V_{IN} \leq 5.5\text{V}$ ; $2.5\text{V} \leq V_{DXX} \leq 3.9\text{V}$ ; $R_{SET} = 12.5\text{k}\Omega$		10		<b>mA</b>
		$2.7\text{V} \leq V_{IN} \leq 3.0\text{V}$ ; $2.5\text{V} \leq V_{DXX} \leq 3.3\text{V}$ ; $R_{SET} = 8.35\text{k}\Omega$		15		<b>mA</b>
		ENA and ENB ON (all 7 $I_{DXX}$ outputs active), $V_{IN} = 3.0\text{V}$ , $C_{IN} = C_{OUT} = 2.2\mu\text{F}$		15		<b>mA</b>
$I_{DXX-MATCH}$	Current Matching Between Any Two Group A Outputs or Group B Outputs	$V_{IN} = 3.0\text{V}$ (Note 10)		1		<b>%</b>
$I_Q$	Quiescent Supply Current	$2.7\text{V} \leq V_{IN} \leq 4.2\text{V}$ ; No Load Current, EN = ON, ENA = ENB = OFF		3.5	<b>6</b>	<b>mA</b>
$I_{SD}$	Shutdown Supply Current	$2.7\text{V} \leq V_{IN} \leq 5.5\text{V}$ , EN = OFF		3	<b>4.5</b>	<b><math>\mu\text{A}</math></b>
$V_{SET}$	$I_{SET}$ Pin Voltage	$2.7\text{V} \leq V_{IN} \leq 5.5\text{V}$		1.25		<b>V</b>
$I_{DXX}/I_{SET}$	Output Current to Current Set Ratio			100		
$R_{OUT}$	Charge Pump Output Resistance (Note 11)	$V_{IN} = 3.0\text{V}$		2.7		<b><math>\Omega</math></b>
$V_{HR}$	Current Source Headroom Voltage Requirement (Note 12)	$I_{DXX} = 95\% \times I_{DXX}(\text{nom})$ $R_{SET} = 8.35\text{k}\Omega$ ( $I_{DXX}(\text{nom}) \approx 15\text{mA}$ )		320		<b>mV</b>
		$I_{DXX} = 95\% \times I_{DXX}(\text{nom})$ $R_{SET} = 12.5\text{k}\Omega$ ( $I_{DXX}(\text{nom}) \approx 10\text{mA}$ )		220		

## Electrical Characteristics (Notes 2, 7) (Continued)

Limits in standard typeface and typical values apply for  $T_J = 25^\circ\text{C}$ . Limits in **boldface** type apply over the full operating junction temperature range ( $-30^\circ\text{C} \leq T_J \leq +85^\circ\text{C}$ ). Unless otherwise specified:  $V_{IN} = 3.6\text{V}$ ;  $V_{Dxx} = 3.6\text{V}$ ;  $V(\text{EN}) = 2.0\text{V}$ ; Group A and Group B LEDs not ON simultaneously ( $\text{ENA} = V_{IN}$  and  $\text{ENB} = \text{GND}$ , or  $\text{ENA} = \text{GND}$  and  $\text{ENB} = V_{IN}$ );  $R_{SET} = 8.35\text{k}\Omega$ ;  $C_{IN}$ ,  $C_1$ ,  $C_2$ , and  $C_{POUT} = 1\mu\text{F}$ . (Note 8)

Symbol	Parameter	Condition	Min	Typ	Max	Units
$f_{\text{SW}}$	Switching Frequency	$3.0\text{V} \leq V_{IN} \leq 4.2\text{V}$	<b>325</b>	500	<b>675</b>	kHz
$t_{\text{START}}$	Start-up Time	$I_{\text{Dx}} = 90\%$ steady state		100		$\mu\text{s}$
1.5x/1x	Charge pump gain cross-over: Gain = 1.5 when $V_{IN}$ is below threshold. Gain = 1 when $V_{IN}$ is above threshold.	1.5x to 1x Threshold		4.75		V
		1x to 1.5x Threshold		4.55		V
<b>Logic Pin Specifications: EN, ENA, ENB</b>						
$V_{IL}$	Input Logic Low	$2.7\text{V} \leq V_{IN} \leq 5.5\text{V}$	<b>0</b>		<b>0.5</b>	V
$V_{IH}$	Input Logic High	$2.7\text{V} \leq V_{IN} \leq 5.5\text{V}$	<b>1.1</b>		<b><math>V_{IN}</math></b>	V
$I_{\text{LEAK}}$	Input Leakage Current	$V_{\text{ENx}} = 0\text{V}$		0.1		$\mu\text{A}$
		$V_{\text{ENx}} = 3\text{V}$ (Note 13)		10		

**Note 1:** Absolute Maximum Ratings indicate limits beyond which damage to the component may occur. Operating Ratings are conditions under which operation of the device is guaranteed. Operating Ratings do not imply guaranteed performance limits. For guaranteed performance limits and associated test conditions, see the Electrical Characteristics tables.

**Note 2:** All voltages are with respect to the potential at the GND pin.

**Note 3:** Internal thermal shutdown circuitry protects the device from permanent damage. Thermal shutdown engages at  $T_J = 160^\circ\text{C}$  (typ.) and disengages at  $T_J = 120^\circ\text{C}$  (typ.). The thermal shutdown function is guaranteed by design.

**Note 4:** The Human body model is a 100pF capacitor discharged through a 1.5k resistor into each pin. The machine model is a 200pF capacitor discharged directly into each pin. MIL-STD-883 3015.7

**Note 5:** In applications where high power dissipation and/or poor package thermal resistance is present, the maximum ambient temperature may have to be derated. Maximum ambient temperature ( $T_{A-MAX}$ ) is dependent on the maximum operating junction temperature ( $T_{J-MAX-OP} = 125^\circ\text{C}$ ), the maximum power dissipation of the device in the application ( $P_{D-MAX}$ ), and the junction-to ambient thermal resistance of the part/package in the application ( $\theta_{JA}$ ), as given by the following equation:  $T_{A-MAX} = T_{J-MAX-OP} - (\theta_{JA} \times P_{D-MAX})$ .

**Note 6:** Junction-to-ambient thermal resistance is highly dependent on application and board layout. In applications where high maximum power dissipation exists, special care must be paid to thermal dissipation issues in board design.

**Note 7:** Min and Max limits are guaranteed by design, test, or statistical analysis. Typical numbers are not guaranteed, but do represent the most likely norm.

**Note 8:**  $C_{IN}$ ,  $C_{OUT}$ ,  $C_1$ , and  $C_2$ : Low-ESR Surface-Mount Ceramic Capacitors (MLCCs) used in setting electrical characteristics

**Note 9:** If both LED groups are to be ON simultaneously, the maximum  $V_{Dxx}$  voltage may need to be derated, depending on minimum input voltage conditions. Refer to the "MAXIMUM OUTPUT CURRENT, MAXIMUM LED VOLTAGE, MINIMUM INPUT VOLTAGE" section.

**Note 10:** For the two groups of outputs on a part (Group A and Group B), the following are determined: the maximum output current in the group (MAX), the minimum output current in the group (MIN), and the average output current of the group (AVG). For each group, two matching numbers are calculated:  $(\text{MAX-AVG})/\text{AVG}$  and  $(\text{AVG-MIN})/\text{AVG}$ . The largest number of the two (worst case) is considered the matching figure for the group. The matching figure for a given part is considered to be the highest matching figure of the two groups. The typical specification provided is the most likely norm of the matching figure for all parts.

**Note 11:** Output resistance ( $R_{OUT}$ ) models all voltage losses in the charge pump.  $R_{OUT}$  can be used to estimate the voltage at the charge pump output ( $P_{OUT}$ ):  $V_{\text{Pout}} = (1.5 \times V_{IN}) - (R_{OUT} \times I_{\text{OUT}})$ . In the equation,  $I_{\text{OUT}}$  is the total output current: the sum of all active Dxx output currents and all current drawn from  $P_{OUT}$ . The equation applies when the charge pump is operating with a gain of 3/2 ( $V_{IN} \leq 4.75\text{V}$  typ.).

**Note 12:** Headroom voltage:  $V_{\text{HR}} = V_{\text{Pout}} - V_{\text{Dxx}}$ . If headroom voltage requirement is not met, LED current regulation will be compromised.

**Note 13:** There is a 300k $\Omega$ (typ.) pull-down resistor connected internally between each enable pin (EN, ENA, ENB) and GND.

**Typical Performance Characteristics** Unless otherwise specified:  $V_{IN} = 3.6V$ ;  $V_{DXX} = 3.6V$ ;  $V(EN) = 2.0V$ ;  $V(ENA) = 2.0V$ ;  $V(ENB) = 0V$ ;  $R_{SET} = 8.3\text{ k}\Omega$ ;  $C_{IN}$ ,  $C_1$ ,  $C_2$ , and  $C_{POUT} = 1\text{ }\mu\text{F}$ .

**LED Current vs. Input Voltage**

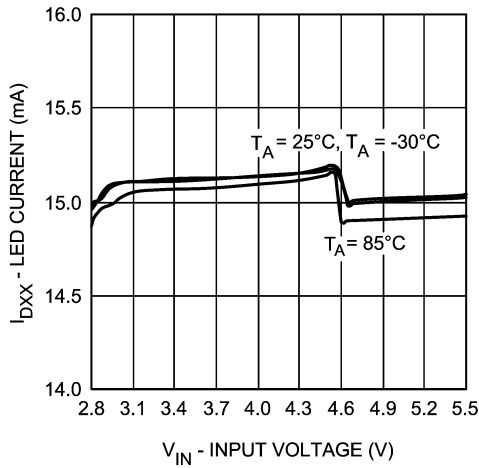

20093803

**LED Current vs.  $R_{SET}$  Resistance**

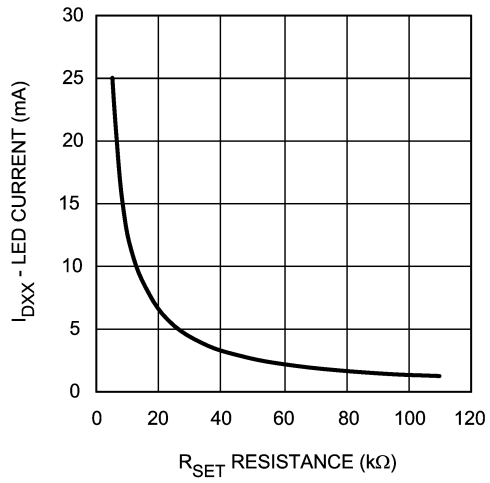

20093804

**LED Current vs. PWM Duty Cycle, PWM Applied to ENA and/or ENB**

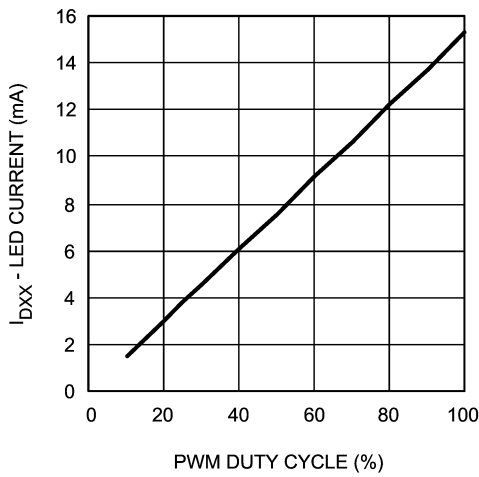

20093805

**Charge Pump Output Resistance vs. Ambient Temperature**

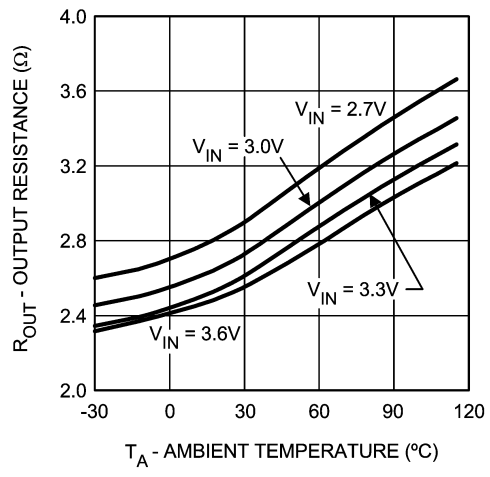

20093806

## Circuit Description

### OVERVIEW

The LM2796 is primarily intended for Lithium-Ion battery driven white-LED drive applications, and is well suited to drive white LEDs that are used for backlighting small-format displays. The part has seven matched constant-current outputs, each capable of driving up to 20mA (or more) through white LEDs. The well-matched current sources ensure the current through all the LEDs is virtually identical. This keeps brightness of all LEDs matched to near perfection so that they can provide a consistent backlight over the entire display.

The core of the LM2796 is a 1.5x/1x dual-mode charge pump. The input of the charge pump is connected to the  $V_{IN}$  pin. The recommended input voltage range of the LM2796 is 2.7V to 5.5V. The output of the charge pump is the  $P_{OUT}$  pin ("Pump OUTput"). The output voltage of the charge pump is unregulated and varies with input voltage and load current.

The charge pump operates in the 1.5x mode when the input voltage is below 4.75V (typ.). In this mode, the input-to-output voltage gain of the charge pump is 1.5, and the voltage at the output of the charge pump will be approximately 1.5x the input voltage ( $V(P_{OUT}) \approx 1.5 \times V_{IN}$ ). When in the 1.5x mode, the charge pump provides the voltage boost that is required to drive white LEDs from a Li-Ion battery. (White LEDs typically have a forward voltage in the range of 3.3V to 4.0V. A Li-Ion battery typically is not considered to be fully discharged until the battery voltage falls to 3.0V (approx.))

The charge pump operates in the 1x mode when the input voltage is above 4.75V (typ.). In these conditions, voltage boost is not required to drive the LEDs, so the charge pump merely passes the input voltage to  $P_{OUT}$  ( $V(P_{OUT}) \approx V_{IN}$ ). This reduces the input current and the power dissipation of the LM2796 when the input voltage is high.

The matched current outputs are generated with a precision current mirror that is biased off the charge pump output. Matched currents are ensured with the use of tightly matched internal devices and internal mismatch cancellation circuitry. Top-side current drive allows LEDs to be connected between each current output and GND, simplifying PWB routing and connectivity.

There are seven regulated current outputs. These seven outputs are split into two groups, a group of 4 outputs and a group of 3 outputs. There is an ON/OFF control pin for each group.

The DC current through the LEDs is programmed with an external resistor. Changing currents on-the-fly can be achieved with the use of digital pulse (PWM) signals.

### ENABLE PINS: EN, ENA, ENB

The LM2796 has 3 enable pins. All three are active-high logic (HIGH = ON). There are internal pull-down resistors (300k $\Omega$  typ.) that are connected internally between each of the enable pins and GND.

The EN pin is the master enable pin for the part. When voltage on this pin is low (<0.5V), the part is in shutdown mode. All internal circuitry is OFF and the part consumes very little supply current when the LM2796 is shutdown. When the voltage on the EN pin is high (>1.1V), the part is active. The charge pump is ON, and it is possible to turn on the output currents to drive the LEDs.

ENA and ENB are used to turn the output currents ON and OFF. ENA activates/deactivates the four group-A outputs (D1A-D4A). ENB activates/deactivates the three group-B outputs (D1B-D3B).

### SETTING LED CURRENTS

The output currents of the LM2796 can be set to a desired value simply by connecting an appropriately sized resistor ( $R_{SET}$ ) between the  $I_{SET}$  pin of the LM2796 and GND. The output currents (LED currents) are proportional to the current that flows out of the  $I_{SET}$  pin. The output currents are a factor of 100 greater than the  $I_{SET}$  current. The feedback loop of an internal amplifier sets the voltage of the  $I_{SET}$  pin to 1.25V (typ.). Placing a resistor between  $I_{SET}$  and GND programs the  $I_{SET}$  current, and thus the LED currents. The statements above are simplified in the equations below:

$$I_{Dxx} = 100 \times (V_{SET} / R_{SET})$$

$$R_{SET} = 100 \times (1.25V / I_{Dxx})$$

### Maximum Output Current, Maximum LED Voltage, Minimum Input Voltage

The LM2796 can drive 7 LEDs at 15mA each from an input voltage as low as 3.0V, so long as the LEDs have a forward voltage of 3.6V or less (room temperature).

The statement above is a simple example of the LED drive capabilities of the LM2796. The statement contains the key application parameters that are required to validate an LED-drive design using the LM2796: LED current ( $I_{LED}$ ), number of active LEDs ( $N$ ), LED forward voltage ( $V_{LED}$ ), and minimum input voltage ( $V_{IN-MIN}$ ).

The equation below can be used to estimate the total output current capability of the LM2796:

$$I_{LED-MAX} = ((1.5 \times V_{IN}) - V_{LED}) / ((N \times R_{OUT}) + k_{HR}) \quad (\text{eq. 1})$$

$$I_{LED-MAX} = ((1.5 \times V_{IN}) - V_{LED}) / ((N \times 2.7\Omega) + 22\text{mV/mA})$$

$R_{OUT}$  – Output resistance. This parameter models the internal losses of the charge pump that result in voltage droop at the pump output  $P_{OUT}$ . Since the magnitude of the voltage droop is proportional to the total output current of the charge pump, the loss parameter is modeled as a resistance. The output resistance of the LM2796 is typically 2.7 $\Omega$  ( $V_{IN} = 3.0V$ ,  $T_A = 25^\circ\text{C}$ ). In equation form:

$$V_{POUT} = 1.5 \times V_{IN} - N \times I_{LED} \times R_{OUT} \quad (\text{eq. 2})$$

$k_{HR}$  – Headroom constant. This parameter models the minimum voltage required to be present across the current sources for them to regulate properly. This minimum voltage is proportional to the programmed LED current, so the constant has units of mV/mA. The typical  $k_{HR}$  of the LM2796 is 22mV/mA. In equation form:

$$(V_{POUT} - V_{LED}) > k_{HR} \times I_{LED} \quad (\text{eq. 3})$$

The " $I_{LED-MAX}$ " equation (eq. 1) is obtained from combining the  $R_{OUT}$  equation (eq. 2) with the  $k_{HR}$  equation (eq. 3) and solving for  $I_{LED}$ . Maximum LED current is highly dependent on minimum input voltage and LED forward voltage. Output current capability can be increased by raising the minimum input voltage of the application, or by selecting an LED with a lower forward voltage. Excessive power dissipation may also limit output current capability of an application.

### Soft Start

The LM2796 contains internal soft-start circuitry to limit input inrush currents when the part is enabled. Soft start is implemented internally with a controlled turn-on of the internal voltage reference. During soft start, the current through the

## Circuit Description (Continued)

LED outputs rise at the rate of the reference voltage ramp. Due to the soft-start circuitry, turn-on time of the LM2796 is approximately 100 $\mu$ s (typ.).

### Thermal Protection

Internal thermal protection circuitry disables the LM2796 when the junction temperature exceeds 160°C (typ.). This feature protects the device from being damaged by high die temperatures that might otherwise result from excessive power dissipation. The device will recover and operate normally when the junction temperature falls below 120°C (typ.). It is important that the board layout provides good thermal conduction. This will help to keep the junction temperature within specified operating ratings.

## Applications Information

### ADJUSTING LED BRIGHTNESS (PWM control)

Perceived LED brightness can be adjusted using a PWM control signal to turn the LM2796 current sources ON and OFF at a rate faster than perceptible by the eye. When this is done, the total brightness perceived is proportional to the duty cycle (D) of the PWM signal (D = the percentage of time that the LED is on in every PWM cycle). A simple example: if the LEDs are driven at 15mA each with a PWM signal that has a 50% duty cycle, perceived LED brightness will be about half as bright as compared to when the LEDs are driven continuously with 15mA. A PWM signal thus provides brightness (dimming) control for the solution.

The minimum recommended PWM frequency is 100Hz. Frequencies below this may be visibly noticeable as flicker or blinking. The maximum recommended PWM frequency is 1kHz. Frequencies above this may cause interference with internal current driver circuitry.

The preferred method for applying a PWM signal to adjust brightness is to keep the master EN voltage ON continuously and to apply the PWM signal(s) to the current source enable pin(s): ENA and/or ENB. The benefit of this type of connection can be best understood with a contrary example. When a PWM signal is connected to the master enable (EN) pin, the charge pump repeatedly turns on and off. Every time the charge pump turns on, there is an inrush of current as capacitances, both internal and external, are recharged. This inrush current results in a current and voltage spike at the input of the part. By only applying the PWM signal to ENA/ENB, the charge pump stays on continuously and much lower input noise results.

In cases where a PWM signal must be connected to the EN pin, measures can be taken to reduce the magnitude of the charge-pump turn-on voltage spikes. More input capacitance, series resistors and/or ferrite beads may provide benefits.

If the current and voltage spikes can be tolerated, connecting the PWM signal to the EN pin does provide a benefit: lower supply current when the PWM signal is active. When the PWM signal is low, the LM2796 will be shutdown and input current will only be a few micro-amps. This results in a lower time-averaged input current than the prior suggestion, where EN is kept on continuously.

### CAPACITOR SELECTION

The LM2796 requires 4 external capacitors for proper operation. Surface-mount multi-layer ceramic capacitors are recommended. These capacitors are small, inexpensive and have very low equivalent series resistance (ESR <20mW typ.). Tantalum capacitors, OS-CON capacitors, and aluminum electrolytic capacitors are not recommended for use with the LM2796 due to their high ESR, as compared to ceramic capacitors.

For most applications, ceramic capacitors with X7R or X5R temperature characteristic are preferred for use with the LM2796. These capacitors have tight capacitance tolerance (as good as  $\pm 10\%$ ) and hold their value over temperature (X7R:  $\pm 15\%$  over -55°C to 125°C; X5R:  $\pm 15\%$  over -55°C to 85°C).

Capacitors with Y5V or Z5U temperature characteristic are generally not recommended for use with the LM2796. Capacitors with these temperature characteristics typically have wide capacitance tolerance (+80%, -20%) and vary significantly over temperature (Y5V: +22%, -82% over -30°C to +85°C range; Z5U: +22%, -56% over +10°C to +85°C range). Under some conditions, a nominal 1 $\mu$ F Y5V or Z5U capacitor could have a capacitance of only 0.1 $\mu$ F. Such detrimental deviation is likely to cause Y5V and Z5U capacitors to fail to meet the minimum capacitance requirements of the LM2796.

The minimum recommended voltage rating for these capacitors is 10V.

### MICRO SMD MOUNTING

The LM2796 is an 18-bump micro SMD with a bump size of approximately 300 micron diameter. The micro SMD package requires specific mounting techniques detailed in National Semiconductor Application Note 1112 (AN-1112).

## Physical Dimensions inches (millimeters) unless otherwise noted

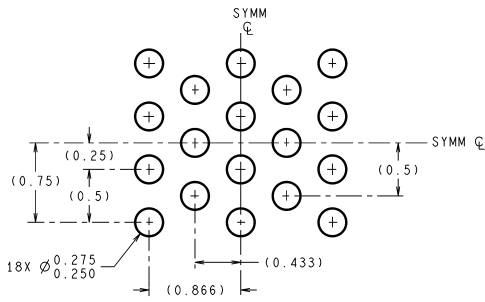

**DIMENSIONS ARE IN MILLIMETERS**  
DIMENSIONS IN ( ) FOR REFERENCE ONLY

### LAND PATTERN RECOMMENDATION

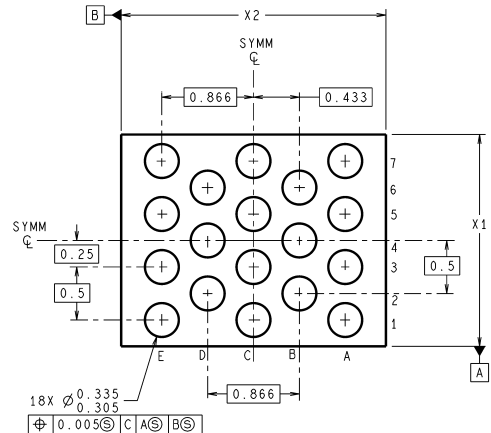
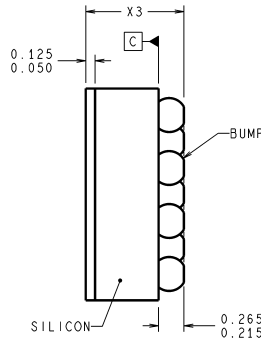
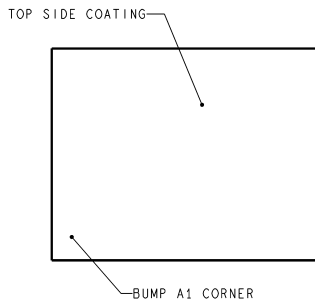

TLA18XXX (Rev C)

### TLA18EHA: 18-Bump Thin Micro SMD, Large Bump

**X1 = 2.098 ± 0.030mm**

**X2 = 2.403mm ± 0.030**

**X3 = 0.600mm ± 0.075mm**

### LIFE SUPPORT POLICY

NATIONAL'S PRODUCTS ARE NOT AUTHORIZED FOR USE AS CRITICAL COMPONENTS IN LIFE SUPPORT DEVICES OR SYSTEMS WITHOUT THE EXPRESS WRITTEN APPROVAL OF THE PRESIDENT AND GENERAL COUNSEL OF NATIONAL SEMICONDUCTOR CORPORATION. As used herein:

1. Life support devices or systems are devices or systems which, (a) are intended for surgical implant into the body, or (b) support or sustain life, and whose failure to perform when properly used in accordance with instructions for use provided in the labeling, can be reasonably expected to result in a significant injury to the user.
2. A critical component is any component of a life support device or system whose failure to perform can be reasonably expected to cause the failure of the life support device or system, or to affect its safety or effectiveness.

### BANNED SUBSTANCE COMPLIANCE

National Semiconductor certifies that the products and packing materials meet the provisions of the Customer Products Stewardship Specification (CSP-9-111C2) and the Banned Substances and Materials of Interest Specification (CSP-9-111S2) and contain no "Banned Substances" as defined in CSP-9-111S2.



**National Semiconductor**  
Americas Customer  
Support Center  
Email: [new.feedback@nsc.com](mailto:new.feedback@nsc.com)  
Tel: 1-800-272-9959

**National Semiconductor**  
Europe Customer Support Center  
Fax: +49 (0) 180-530 85 86  
Email: [europe.support@nsc.com](mailto:europe.support@nsc.com)  
Deutsch Tel: +49 (0) 69 9508 6208  
English Tel: +44 (0) 870 24 0 2171  
Français Tel: +33 (0) 1 41 91 8790

**National Semiconductor**  
Asia Pacific Customer  
Support Center  
Email: [ap.support@nsc.com](mailto:ap.support@nsc.com)

**National Semiconductor**  
Japan Customer Support Center  
Fax: 81-3-5639-7507  
Email: [jpn.feedback@nsc.com](mailto:jpn.feedback@nsc.com)  
Tel: 81-3-5639-7560

[www.national.com](http://www.national.com)