

March 17, 1998

TEL:805-498-2111 FAX:805-498-3804 WEB:http://www.semtech.com

DESCRIPTION

The LP2951 series of low power voltage regulators have low quiescent current and low dropout voltage. The quiescent current increases minimally during dropout conditions thereby extending battery life.

Available in the 8 lead SOIC package, the LP2951 series includes features such as shutdown and low output voltage detect (typically due to low battery conditions). This function may also be used as a power on reset function when triggered by CMOS or TTL inputs. The circuit can be used as a fixed voltage 5 volt (3.3 volt for LP2951CM-3.3) regulator or adjusted between 1.24 volts and 29 volts using external resistor pairs.

BLOCK DIAGRAM

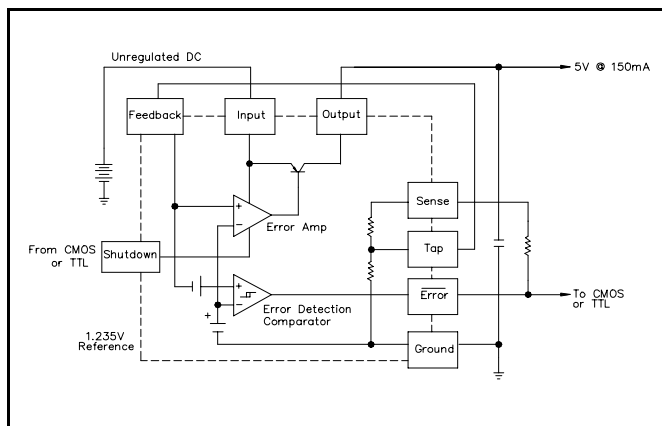

PIN CONFIGURATION

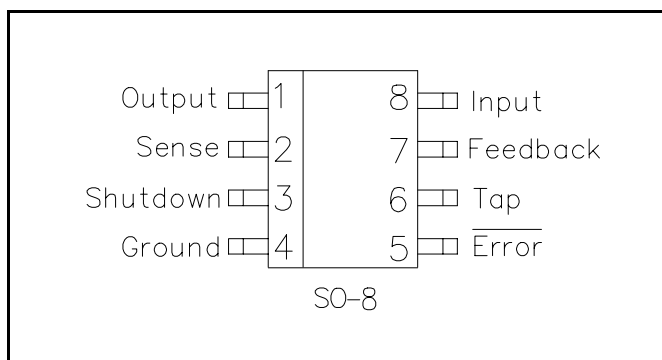

FEATURES

- Guaranteed 150mA current
- Adjustable output voltage - 1.24V to 29V
- Accurate 5V or 3.3V output @ 100mA
- Low dropout voltage - 350-400mV @ 100mA
- Regulator or reference functions
- Direct replacement for LP2951C, MIC2951-03, AS2951C

APPLICATIONS

- Microcontroller supplies
- Linear regulators
- Adjustable Supplies
- Switching power supplies - post-regulation
- Portable modems
- Battery powered systems
- Cellular telephones
- Voltage references

ORDERING INFORMATION

DEVICE ⁽¹⁾⁽²⁾	OUTPUT	PACKAGE
LP2951CM-X.X	ADJ	SO-8

Notes:

(1) Where -X.X denotes voltage options. Available voltages are: 3.3V (-3.3) and 5V (leave blank).

(2) Add suffix 'TR' for tape and reel.

ABSOLUTE MAXIMUM RATINGS

Parameter	Symbol	Maximum	Units
Supply Voltage	V_{IN}	-0.3 to 30	V
Shutdown Input Voltage		-0.3 to 30	V
Error Comp. Output Voltage		-0.3 to 30	V
Power Dissipation	P_D	Internally Limited	W
Thermal Resistance Junction to Ambient	θ_{JA}	175	°C/W
Operating Junction Temperature Range	T_J	-40 to 125	°C
Storage Temperature Range	T_{STG}	-65 to 150	°C
Lead Temperature (Soldering) 5 Sec	T_{LEAD}	260	°C

March 17, 1998

ELECTRICAL CHARACTERISTICS

 Unless specified, limits are over operating temperature range ($T_J = T_A$), $V_{IN} = V_{OUT(NOM)} + 1V$, $I_L = 100\mu A$, $C_L = 1\mu F$

Parameter	Symbol	Conditions	Min	Typ	Max	Units
Output Voltage LP2951CM	V_{OUT}	$T_J = 25^\circ C, I_L = 100\mu A$	4.950	5.000	5.050	V
LP2951CM-3.3			3.267	3.300	3.333	
Temp Coefficient ⁽¹⁾	T_C	$0^\circ C \leq T_J \leq 70^\circ C$		20	120	ppm/ $^\circ C$
Line Regulation	$REG_{(LINE)}$	$(V_{O(NOM)} + 1V) \leq V_{IN} \leq 30V$		0.1	0.5	%
Load Regulation	$REG_{(LOAD)}$	$100\mu A \leq I_L \leq 100mA$		0.1	0.4	%
Dropout Voltage	V_D	$I_L = 100\mu A$		80	150	mV
		$I_L = 100mA$		380	600	
Ground Current	I_{GND}	$I_L = 100\mu A$		120	160	μA
		$I_L = 100mA$		8	14	mA
Dropout Ground Current	$I_{GND(D)}$	$V_{IN} = (V_{O(NOM)} - 0.5V), I_L = 100\mu A$		110	250	μA
Current Limit	I_{CL}	$V_{OUT} = 0$		200	250	mA
Reference Voltage	V_{REF}	$V_{REF} \leq V_{OUT} \leq (V_{IN} - 1V), T_J = 25^\circ C,$ $100\mu A \leq I_L \leq 100mA$	1.210	1.235	1.260	V
Feedback Bias Current	I_{FB}			20	60	nA
Error Comparator						
Output High Leakage Current		$V_{OH} = 30V$			2	μA
Output Low Voltage		$V_{IN} = (V_{O(NOM)} - 0.5V), I_{OL} = 400\mu A$		150	400	mV
Threshold Voltage		Upper	25	60		mV
		Lower		75	140	
Hysteresis				15		mV
Shutdown Input						
Input Logic Voltage	V_{SD}	Low			0.6	V
		High	2.0			V
Input Current	I_{SD}	$V_{SHUTDOWN} = 2.4V$			100	μA
		$V_{SHUTDOWN} = 30V$			750	
Regulator Shutdown Output Current	$I_{O(SD)}$	$V_{SHUTDOWN} \geq 2V, V_{IN} \leq 30V,$ $V_{OUT} = 0, \text{Feedback pin to Tap}$			20	μA

NOTE:

(1) Temperature coefficient is defined as the worst case voltage change divided by total temperature range.

March 17, 1998

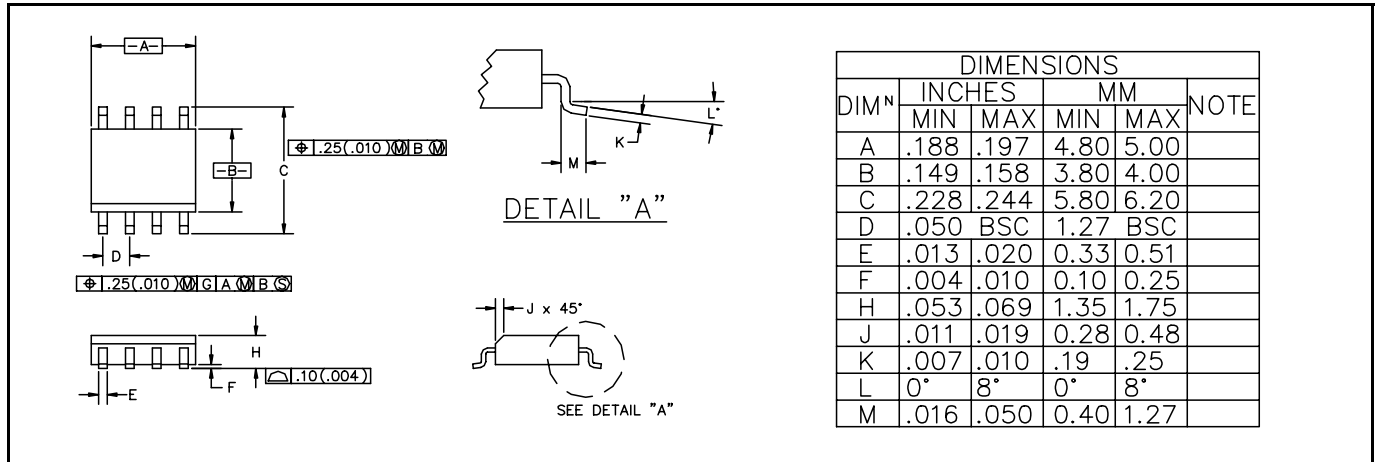
OUTLINE DRAWING SO-8

LAND PATTERN SO-8
