

## LP3928

# High Speed Bi-Directional Level Shifter and Ultra Low-Dropout CMOS Voltage Regulator

### General Description

The LP3928 is designed for portable and wireless applications with demanding performance and space requirements.

The LP3928 provides level shifting and power conversion needed for applications interfacing differing voltage levels.

The part contains a bi-directional level shifter for three signals to translate the levels between 1.8V and 2.85V and an ultra low-dropout CMOS 2.85V voltage regulator.

The three level shifted signals are individually direction controlled. Signals going from 2.85V to 1.8V can also be latched using an external clock source. The latches are powered from internal 2.85V. There is also an option to by-pass the latches.

The built-in low-dropout voltage regulator is ideal for mobile phone and battery powered wireless applications. It provides up to 150 mA from a 3.05V to 6.0V input, and is characterized by extremely low dropout voltage, low quiescent current and low output noise voltage. It is stable with small 1.5  $\mu$ F  $\pm$ 30% ceramic and high quality tantalum output capacitors, requiring smallest possible PC board area.

A shutdown mode is available for the level shifters and the regulator. High performance is achieved over various load conditions with very low rise and fall times.

### Key Specifications

Level Shifter:

- 4 ns propagation delay (typ.)

- 2 ns rise and fall times (typ.)
- 20 ns direction switch response time
- 2  $\mu$ A input/output leakage current

Low-Dropout Regulator:

- 3.05V to 6.0V input range
- 150 mA guaranteed output
- Fast Turn-On time: 200  $\mu$ s (typ.)
- 100 mV maximum dropout with 150 mA load

### Features

- Ultra small micro SMD package
- Bi-directional level-shifter for three individual signals: 1.8V to 2.85V and 2.85V to 1.8V signal level translation
- Logic controlled enable pins: 4 different operation modes
- LDO stable with ceramic and high quality tantalum capacitors
- Thermal shutdown

### Applications

- Multi-Media Cards for Cellular Phones
- SD Cards for Cellular Handsets
- Logic Level Translation
- Portable Information Appliances

### Typical Application Circuit

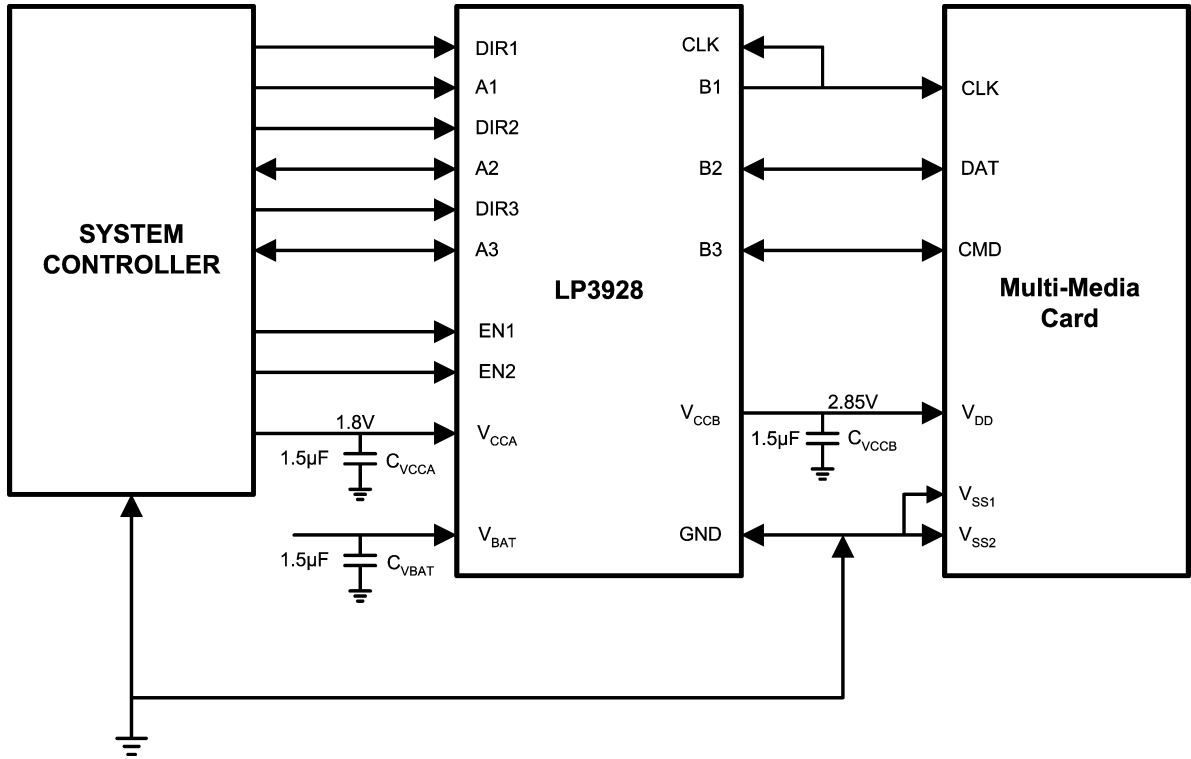

20039101

### Block Diagram

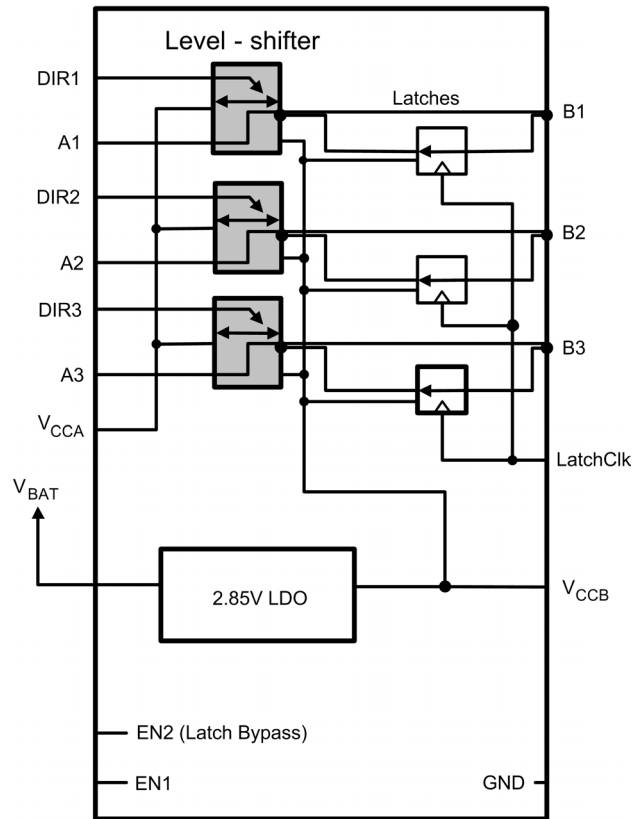

20039102

## Package Outline and Connection Diagrams

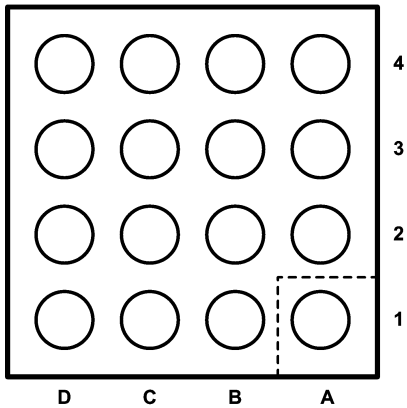

20039103  
**Bottom View**  
**16 Bump micro SMD Package**  
 See NSC Package Number TLA16AAA

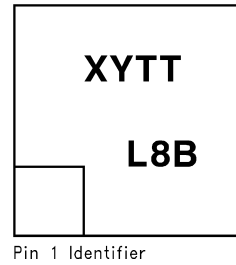

**Note:** The actual physical placement of the package marking will vary from part to part. The package marking "XY" will designate the date code, "TT" is a NSC internal code for die traceability. Both will vary considerably. L8B identifies the device.

**Top View**

## Pin Description

Pin Name	micro SMD Bump Identifier	Logic Level	Function
A1	C4	1.8V	1.8V I/O Channel, (Note 1)
A2	D4	1.8V	1.8V I/O Channel, (Note 1)
A3	D3	1.8V	1.8V I/O Channel, (Note 1)
B1	C1	2.85V	2.85V I/O Channel, (Note 1)
B2	D1	2.85V	2.85V I/O Channel, (Note 1)
B3	D2	2.85V	2.85V I/O Channel, (Note 1)
DIR1	B3	1.8V	Direction control input Channel 1: '1': A→B; 0; B→A
DIR2	B2	1.8V	Direction control input Channel 2: '1': A→B; 0; B→A
DIR3	C3	1.8V	Direction control input Channel 3: '1': A→B; 0; B→A
V <sub>CCA</sub>	B4		IC supply to the 1.8V side
V <sub>CCB</sub>	B1		IC supply, 2.85V output from LDO
V <sub>BAT</sub>	A1		LDO supply, Battery voltage
GND	A3		Power ground connection
EN1	A4	1.8V	Mode pin 1, see <i>Table 1</i> for modes and settings
EN2	A2	1.8V	Mode pin 2, see <i>Table 1</i> for modes and settings
LatchClk	C2	2.85V	Clock input: rising edge latches B inputs (DIR=0, normal mode)

**Note 1:** Pin pairs A1–B1, A2–B2 and A3–B3 form 3 independent bi-directional level-shifting channels.

**TABLE 1. Operation Modes**

Inputs		State
EN1	EN2	
0	0	Level shifter off: High Z state on A <sub>1</sub> –A <sub>3</sub> , B <sub>1</sub> –B <sub>3</sub> , LDO off
0	1	Level shifter off: High Z state on A <sub>1</sub> –A <sub>3</sub> , B <sub>1</sub> –B <sub>3</sub> , LDO on
1	0	Latch bypassed in B to A direction, LDO=on (Note 2)
1	1	ON, normal mode (latch active)

**Note 2:** LatchClk is not used here. It should not be left floating.

# Pin Description (Continued)

**TABLE 2. Direction Control and LatchCLK (Normal Mode)**

Inputs		Outputs and Direction
DIRx	LatchClk	
1	X	Ax to Bx
0	↓	No change (on Ax)
0	↑	Bx to Ax, see example

Example for Latch Mode, DIR1 = '0', EN1 = EN2 = '1' (delay not shown):

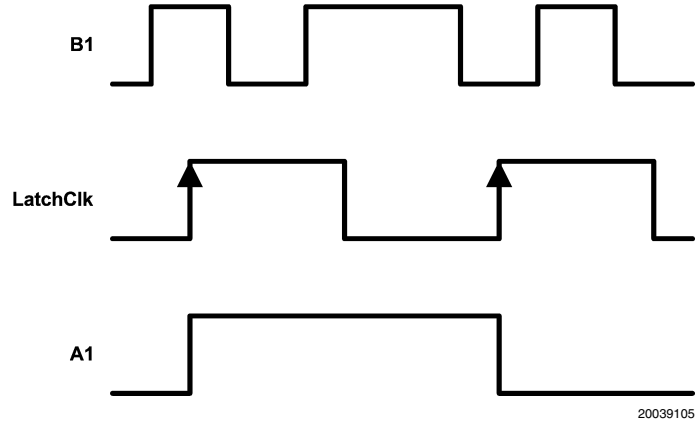

## Ordering Information

For micro SMD Package

Output Voltage (V)	Grade	LP3928 Supplied As 250 Units, Tape & Reel	LP3928 Supplied As 3000 Units, Tape & Reel
2.85	STD	LP3928TL-1828	LP3928TLX-1828

**Absolute Maximum Ratings** (Notes 3,

4)

If Military/Aerospace specified devices are required, please contact the National Semiconductor Sales Office/Distributors for availability and specifications.

$V_{BAT}, V_{CCB}$	-0.2V to +6.5V
$V_{CCA}$	-0.2V to +3.3V
$A_1-A_3, EN, DIR$	-0.2V to $V_{CCA} + 0.2V$
$B_1-B_3, LatchClk$	-0.2V to $V_{CCB} + 0.2V$
Junction Temperature	150°C
Storage Temperature	-65°C to +150°C
Lead Temperature (Note 27)	235°C
Pad Temperature (Note 27)	235°C
Power Dissipation (Note 5)	
$\theta_{JA}$ (micro SMD), typical	180°C/W

Maximum Power Dissipation

micro SMD

360 mW

ESD Rating (Note 6)

Human Body Model

2 kV

**Operating Conditions** (Notes 3, 4)

$V_{BAT}$	3.05V to 6.0V
$V_{CCA}$	1.65V to 1.95V
$V_{CCB}$	(Note 7)
Junction Temperature	-40°C to +125°C
Ambient Temperature	-40°C to +85°C
Maximum Power Dissipation (Note 8)	220 mW

**Electrical Characteristics**

Unless otherwise specified: H =  $V_{IH}$  min, L =  $V_{IL}$  max,  $C_{VBAT} = 1 \mu F$ ,  $I_{OUT} = 1$  mA,  $C_{VCCB} = 1 \mu F$ ,  $C_{VCCA} = 1 \mu F$ . Typical values and limits appearing in standard typeface apply for  $T_J = 25^\circ C$ . Limits appearing in **boldface type** apply over the entire junction temperature range for operation, -40°C to +125°C. (Note 9)

**Level Shifter DC Voltage Levels**

Unless otherwise specified: EN1 = H, EN2 = X;  $3.05V \leq V_{BAT} \leq 6V$ ,  $1.65V \leq V_{CCA} \leq 1.95V$ .

Symbol	Parameter	Conditions	Min	Typ	Max	Units
$V_{IHA}$	High Level Input Voltage	For A Pins	$V_{CCA}$ * <b>0.65</b>		$V_{CCA}$ + <b>0.2</b>	V
$V_{ILA}$	Low Level Input Voltage		<b>0</b>		$V_{CCA}$ * <b>0.35</b>	V
$V_{OHA}$	High Level Output Voltage	For A Pins	$I_{OH}=4$ mA	1.5	$V_{CCA}$ + <b>0.2</b>	V
$V_{OLA}$	Low Level Output Voltage					
$V_{IHB}$	High Level Input Voltage	For B Pins	$V_{CCB}$ * <b>0.7</b>		$V_{CCB}$ + <b>0.2</b>	V
$V_{ILB}$	Low Level Input Voltage		<b>0</b>		$V_{CCB}$ * <b>0.3</b>	V
$V_{OHB}$	High Level Output Voltage	For B Pins	$I_{OH}=4$ mA	2.75	$V_{CCB}$ + <b>0.2</b>	V
$V_{OLB}$	Low Level Output Voltage					
$V_{IHEN-Dir}$	High Level Input Voltage	For EN and DIR Pins	$V_{CCA}$ * <b>0.75</b>		$V_{CCA}$ + <b>0.2</b>	V
$V_{ILEN-Dir}$	Low Level Input Voltage		<b>0</b>		$V_{CCA}$ * <b>0.27</b>	V
$V_{IHLatClk}$	High Level Input Voltage	For LatchClk Pin	$V_{CCB}$ * <b>0.7</b>		$V_{CCB}$ + <b>0.2</b>	V
$V_{ILLatClk}$	Low Level Input Voltage		<b>0</b>		$V_{CCA}$ * <b>0.3</b>	V

**Level Shifter DC Current Levels**

Unless otherwise specified: EN1 = H, EN2 = X;  $V_{BAT} = 6V$  or  $V_{CCA} = 1.95V$  as applicable to B or A respectively.

Symbol	Parameter	Conditions	Min	Typ	Max	Units
$I_{IA}$	Input Leakage Current $I_{iA}$	$V_{iA}=0/1.9V$ , $DIR_i=H$ ( $V_{CCA} = 1.8V$ when $V_{iA} = 1.9V$ )		0.001	<b><math>\pm 2</math></b>	$\mu A$
$I_{IDIR-EN}$	Input Leakage Current DIR/EN (Note 11)	$V_i=0/1.9V$ ( $V_{CCA} = 1.8V$ when $V_i = 1.9V$ )		0.001	<b><math>\pm 2</math></b>	$\mu A$
$I_{IB}$	Input Leakage Current $I_{iB}$ , LatchClk (Note 12)	$V_{iB}=0/2.95V$ , $DIR_i=L$		0.001	<b><math>\pm 2</math></b>	$\mu A$
$I_{CHA \rightarrow B}$	Static $I_{CCB}$ Current/Channel Static $I_{CCB}$ Current Total (Notes 13, 17)	EN2=H, $DIR_i=H$ , Total Includes $I_{BCOM}$		550 2050	<b>875</b> <b>3330</b>	$\mu A$
$I_{CHB \rightarrow A}$	Static $I_{CCB}$ Current/Channel Static $I_{CCB}$ Current Total (Notes 14, 17)	EN2=L, $DIR_i=L$ Total Includes $I_{BCOM}$		2 406	<b>30</b> <b>840</b>	$\mu A$

**Electrical Characteristics** Unless otherwise specified:  $H = V_{IH}$  min,  $L = V_{IL}$  max,  $C_{VBAT} = 1 \mu F$ ,  $I_{OUT} = 1$  mA,  $C_{VCCB} = 1 \mu F$ ,  $C_{VCCA} = 1 \mu F$ . Typical values and limits appearing in standard typeface apply for  $T_J = 25^\circ C$ . Limits appearing in **boldface type** apply over the entire junction temperature range for operation,  $-40^\circ C$  to  $+125^\circ C$ . (Note 9) (Continued)

### Level Shifter DC Current Levels (Continued)

Unless otherwise specified:  $EN1 = H$ ,  $EN2 = X$ ;  $V_{BAT} = 6V$  or  $V_{CCA} = 1.95V$  as applicable to B or A respectively.

Symbol	Parameter	Conditions	Min	Typ	Max	Units
$I_{BCOM}$	Common Static Level-Shifter $I_{CCB}$ Current (Notes 15, 17)			400	<b>750</b>	$\mu A$
$I_A$	Static Level-Shifter $I_{CCA}$ Current (Notes 16, 17)			90	<b>165</b>	$\mu A$
$I_{CCBEXT}$	Off State $I_{CCB}$ Current with External $V_{CCB}$ (Note 7)	$V_{BAT}=3.6V$ , $EN1=L$ , $EN2=L$		15		$\mu A$
$I_{OFFA}$	Off State $V_{CCA}$ Current	$V_{CCA}=1.9V$ , $EN1,2=0$ , $Ai=0V$ , $Bi=0V$ , $DIRi=0V$ , $LatchClk=0V$		1.5	<b>5</b>	$\mu A$
$I_{OFFBAT}$	Off State $V_{BAT}$ Current	$EN1,2=L$		0.005	<b>3</b>	$\mu A$
$I_{OZA}$	Output Leakage Current $Ai$	$V_{CCA}=1.9V$ , $Vi_A=0/1.9V$ , $EN1=L$		0.001	<b><math>\pm 2</math></b>	$\mu A$
$I_{OZB}$	Output Leakage Current $Bi$	$Vi_B=0V$ , $V_{BAT}=3.35V$ , $V_{CCB}=0$ , $EN1=L$		0.001	<b><math>\pm 2</math></b>	$\mu A$
		$Vi_B=2.95V$ , $V_{BAT}=3.35V$ , $V_{CCB}=2.95V$ , $EN1=L$		0.001	<b><math>\pm 2</math></b>	$\mu A$
$I_{SCA}$	Short Circuit Current/ Channel $Ai$ Output, $V_{CCA}=1.9V$ , $DIRi=L$ , $EN2=L$	$Ai=0V$ , $Bi=H$	<b>-27</b>	-17		mA
		$Ai=V_{CCA}$ , $Bi=L$		36	<b>56</b>	mA
$I_{SCB}$	Short Circuit Current/ Channel $Bi$ Output, $V_{BAT}=2.95V$ , $DIRi=H$	$Bi=0V$ , $Ai=H$	<b>-90</b>	-58		mA
		$Bi=2.95V$ , $Ai=L$		60	<b>90</b>	mA

### Level Shifter AC Electrical Characteristics

Unless otherwise specified:  $EN1 = H$ ,  $3.05V \leq V_{BAT} \leq 6V$ ,  $1.65V \leq V_{CCA} = 1.95V$ . ((Note 28), (Note 29))

Symbol	Parameter	Conditions	Min	Typ	Max	Units
$t_{PHL}$	Propagation Delay $A_n$ to $B_n$ or $B_n$ to $A_n$	$C_{LB} = 35$ pF, $C_{LA} = 15$ pF		4	<b>7</b>	ns
$t_{PLH}$		$C_{LB} = 35$ pF, $C_{LA} = 15$ pF		4	<b>7</b>	ns
$t_R$	Rise Time	$C_{LB} = 35$ pF, $C_{LA} = 15$ pF		2	<b>4</b>	ns
$t_F$	Fall Time	$C_{LB} = 35$ pF, $C_{LA} = 15$ pF		2	<b>4</b>	ns
$t_{MATCH}$	Delay Differences between Channel Outputs at Identical Input Signals				<b>1.5</b>	ns
$t_{SL}$	Latch Set Up Time			1	<b>2</b>	ns
$t_{HL}$	Latch Hold Time			1	<b>2</b>	ns
$t_{LS}$	Level-Shifter Mode Switch Response Time	(Note 18)			<b>100</b>	ns
$t_{DIR}$	Level-Shifter Direction Switch Response Time	(Note 19)			<b>20</b>	ns

### LDO Electrical Characteristics

Unless otherwise specified:  $EN1 = L$ ,  $EN2 = H$ ;  $V_{OUTnom} = 2.85V$ ,  $V_{BAT} = V_{OUT(nom)} + 0.5V$ .

Symbol	Parameter	Conditions	Typical	Limit		Units
				Min	Max	
$\Delta V_{OUT}$	Output Voltage Tolerance	$I_{OUT} = 1$ mA		-2	2	% of $V_{OUT(nom)}$
	Line Regulation Error (Note 20)	$V_{BAT} = (V_{OUT(nom)} + 0.5V)$ to $6.0V$ , $I_{OUT} = 1$ mA		<b>-0.10</b>	<b>0.10</b>	%/V
	Load Regulation Error (Note 21)	$I_{OUT} = 1$ mA to $150$ mA			<b>0.005</b>	%/mA
	Output AC Line Regulation	$V_{BAT} = V_{OUT(nom)} + 1V$ , $I_{OUT} = 100$ mA, $C_{OUT} = 4.7 \mu F$ (Figure 1)	1.5			mV <sub>PP</sub>

**Electrical Characteristics**

Unless otherwise specified: H =  $V_{IH}$  min, L =  $V_{IL}$  max,  $C_{VBAT} = 1 \mu\text{F}$ ,  $I_{OUT} = 1 \text{ mA}$ ,  $C_{VCCB} = 1 \mu\text{F}$ ,  $C_{VCCA} = 1 \mu\text{F}$ . Typical values and limits appearing in standard typeface apply for  $T_J = 25^\circ\text{C}$ . Limits appearing in **boldface type** apply over the entire junction temperature range for operation,  $-40^\circ\text{C}$  to  $+125^\circ\text{C}$ . (Note 9) (Continued)

**LDO Electrical Characteristics** (Continued)

Unless otherwise specified: EN1 = L, EN2 = H;  $V_{OUT(nom)} = 2.85\text{V}$ ,  $V_{BAT} = V_{OUT(nom)} + 0.5\text{V}$ .

Symbol	Parameter	Conditions	Typical	Limit		Units
				Min	Max	
PSRR	Power Supply Rejection Ratio (Note 29)	$V_{BAT} = V_{OUT(nom)} + 1\text{V}$ , $f = 1 \text{ kHz}$ , $I_{OUT} = 50 \text{ mA}$ , (Figure 2)	40			dB
		$V_{BAT} = V_{OUT(nom)} + 1\text{V}$ , $f = 50 \text{ kHz}$ , $I_{OUT} = 50 \text{ mA}$ , (Figure 2)	20			
$I_Q$	Quiescent Current	$I_{OUT} = 1 \text{ mA}$	85		<b>150</b>	$\mu\text{A}$
		$I_{OUT} = 1 \text{ mA to } 150 \text{ mA}$	130		<b>200</b>	
$\Delta V_{DO}$	Dropout Voltage (Note 22)	$I_{OUT} = 1 \text{ mA}$	0.4		<b>2</b>	mV
		$I_{OUT} = 50 \text{ mA}$	20		<b>35</b>	
		$I_{OUT} = 100 \text{ mA}$	45		<b>70</b>	
		$I_{OUT} = 150 \text{ mA}$	60		<b>100</b>	
$I_{SC}$	Short Circuit Current Limit	$V_{BAT} = 6\text{V}$ , Output Grounded (Steady State)	500			mA
$I_{OUT(PK)}$	Peak Output Current	$V_{OUT} \geq V_{OUT(nom)} - 5\%$ , $V_{BAT} = 6\text{V}$	460	<b>200</b>		mA
$T_{ON}$	Turn-On Time (Note 23) (Note 29)		200	<b>130</b>	<b>430</b>	$\mu\text{s}$
$\rho_n$ (1/f)	Output Noise Density	$f = 1 \text{ kHz}$ , $C_{OUT} = 1 \mu\text{F}$	0.6			$\mu\text{V}/\sqrt{\text{Hz}}$
$e_n$	Output Noise Voltage	$\text{BW} = 10 \text{ Hz to } 100 \text{ kHz}$ , $C_{OUT} = 1 \mu\text{F}$	45			$\mu\text{V}_{\text{rms}}$
Output Capacitor	Output Filter Capacitance (Note 24)	$V_{BAT} = 3.05\text{V to } 6\text{V}$ , $I_{OUT} = 1 \text{ mA to } 150 \text{ mA}$		<b>1</b>	<b>22</b>	$\mu\text{F}$
	Output Filter Capacitance ESR (Note 25)	$V_{BAT} = 3.05\text{V to } 6\text{V}$ , $I_{OUT} = 1 \text{ mA to } 150 \text{ mA}$		<b>5</b>	<b>500</b>	$\text{m}\Omega$
Thermal Shutdown	Thermal Shutdown Temperature (Note 26)		160			$^\circ\text{C}$
	Thermal Shutdown Hysteresis		20			$^\circ\text{C}$

**Note 3:** Absolute Maximum Ratings are limits beyond which damage to the device may occur. Operating Ratings are conditions under which operation of the device is guaranteed. Operating Ratings do not imply guaranteed performance limits. For guaranteed performance limits and associated test condition, see Electrical Characteristics tables.

**Note 4:** All voltages are with respect to the potential at the GND pin.

**Note 5:** The Absolute Maximum power dissipation depends on the ambient temperature and can be calculated using the formula

$$P = (T_J - T_A)/\theta_{JA}, \quad (1)$$

Where  $T_J$  is the junction temperature,  $T_A$  is the ambient temperature, and  $\theta_{JA}$  is the junction-to-ambient thermal resistance. The 360 mW rating appearing under Absolute Maximum Ratings results from substituting the Absolute Maximum junction temperature,  $150^\circ\text{C}$ , for  $T_J$ ,  $85^\circ\text{C}$  for  $T_A$ , and  $180^\circ\text{C/W}$  for  $\theta_{JA}$ . More power can be dissipated safely at ambient temperatures below  $85^\circ\text{C}$ . The thermal resistance can be better or worse than  $180^\circ\text{C/W}$  depending on board layout. Larger copper planes and thermal vias should be used to conduct heat away from the micro SMD solder bumps.

**Note 6:** The Human Body Model is 100 pF discharged through 1.5 k $\Omega$  resistor into each pin.

**Note 7:**  $V_{CCB}$  can be supplied from an external voltage source in the range of 1.65V to 3.6V, as long as both  $V_{BAT}$  and  $V_{CCB}$  are connected to the external source. Only the LDO quiescent current (see DC electrical specifications) will add to the level-shifter current consumption. This Operating Rating does not imply guaranteed performance. For guaranteed performance limits and associated test conditions, see Electrical Characteristics tables.

**Note 8:** Like the Absolute Maximum power dissipation, the maximum power dissipation for operation depends on the ambient temperature. The 220 mW rating appearing under Operating Ratings results from substituting the maximum junction temperature for operation,  $125^\circ\text{C}$ , for  $T_J$ ,  $85^\circ\text{C}$  for  $T_A$ , and  $180^\circ\text{C/W}$  for  $\theta_{JA}$  into (1) above. More power can be dissipated at ambient temperatures below  $85^\circ\text{C}$ . The thermal resistance can be better or worse than  $180^\circ\text{C/W}$  depending on board layout. Larger copper planes and thermal vias should be used to conduct heat away from the micro SMD solder bumps.

**Note 9:** All limits are guaranteed. All electrical characteristics having room-temperature limits are tested during production with  $T_J = 25^\circ\text{C}$  or correlated using Statistical Quality Control (SQC) methods. All hot and cold limits are guaranteed by correlating the electrical characteristics to process and temperature variations and applying statistical process control.

**Note 10:** The target output voltage, which is labeled  $V_{OUT(target)}$ , is the desired or ideal output voltage. The nominal output voltage, which is labeled  $V_{OUT(nom)}$ , is the output voltage measured with the input 0.5V above  $V_{OUT(target)}$  and a 1 mA load.

**Note 11:** Input leakage current for pins DIRi, EN1, EN2.

**Note 12:** Input leakage current for pins Bi, LatchClk.

**Note 13:** This is the static current consumption from  $V_{CCB}$  for channel (i) when DIRi=H (A $\rightarrow$ B direction).

**Note 14:** This is the static current consumption from  $V_{CCB}$  for channel (i) when DIRi=L (B $\rightarrow$ A direction).

**Note 15:** This is the static current consumption from  $V_{CCB}$  for the part common to the channels.

**Note 16:** This is the static current consumption from  $V_{CCA}$  for the part common to the channels.

**Note 17:** Only  $I_{CCBTOTAL}$  for  $DIR1=DIR2=DIR3=H$  and  $I_{CCATOTAL}$  for  $DIR1=DIR2=DIR3=L$  will be tested in production.

**Calculation example:** assuming  $DIR1=H$ ,  $DIR2=L$ ,  $DIR3=L$ , then the typical  $I_{CCB}$  current will be:

$$I_{CCBTOTAL} = I_{BCOM} + I_{CHA \rightarrow B} + 2 * I_{CHB \rightarrow A} = 450 \mu A + 530 \mu A + 2 * 2 \mu A = 984 \mu A$$

The typical  $I_{CCA}$  current is:  $I_{CCATOTAL} = I_A = 90 \mu A$ .

**Note 18:** This is the time it takes either to switch the level shifter on or off, or the time it takes to turn the latch by-pass on/off.

**Note 19:** This is the time it takes to switch the direction of the level shifter. After this time a signal can be applied on the new input. For the  $B \rightarrow A$  direction, if  $EN2=1$ , the latch set-up time has to be considered separately.

**Note 20:** The output voltage changes slightly with line voltage. An increase in the line voltage results in a slight increase in the output voltage and vice versa.

**Note 21:** The output voltage changes slightly with load current. An increase in the load current results in a slight decrease in the output voltage and vice versa.

**Note 22:** Dropout voltage is the input-to-output voltage difference at which the output voltage is 100 mV below its normal value. This specification does not apply for input voltages below 2.7V.

**Note 23:** Turn-on time is that between the enable input just exceeding  $V_{IH}$  and the output voltage just reaching 95% of its nominal value.

**Note 24:** Range of capacitor values for which the device will remain stable. This electrical specification is guaranteed by design.

**Note 25:** Range of capacitor ESR values for which the device will remain stable. This electrical specification is guaranteed by design.

**Note 26:** The built-in thermal shut-down of the LDO is also used to put all Ai and Bi outputs in tristate mode.

**Note 27:** Additional information on lead temperature and pad temperature can be found in National Semiconductor Application Note (AN-1112).

**Note 28:** Unused inputs must be terminated.

**Note 29:** This electrical specification is guaranteed by design.

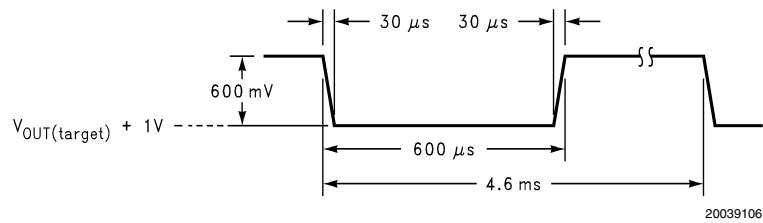

**FIGURE 1. Output AC Line Regulation**

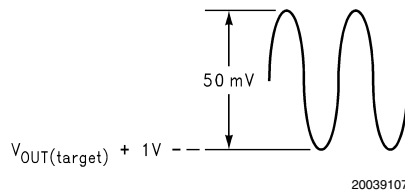

**FIGURE 2. PSRR Input Perturbation**

**Typical Performance Characteristics** Unless otherwise specified:  $C_{VBAT} = 1 \mu F$ ,  $C_{VCCA} = 1 \mu F$ ,  $C_{VCCB} = 1 \mu F$ ,  $V_{BAT} = 3.3V$ ,  $V_{CCA} = 1.8V$ ,  $T_A = 25^\circ C$ .

**Level Shifter Propagation Delay A → B**

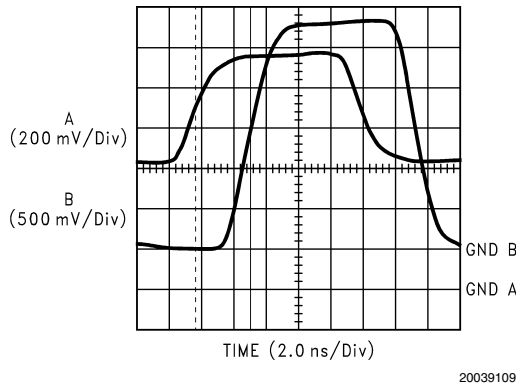

**Level Shifter Propagation Delay B → A**

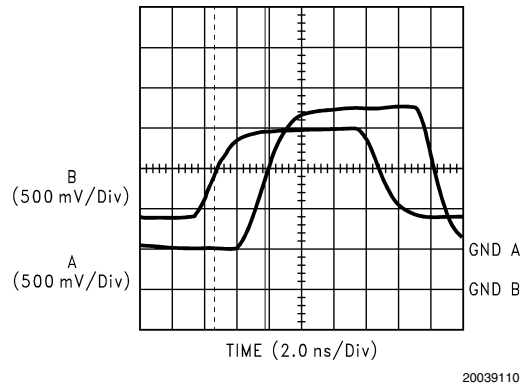



## Typical Performance Characteristics

Unless otherwise specified:  $C_{VBAT} = 1 \mu\text{F}$ ,  $C_{VCCA} = 1 \mu\text{F}$ ,  $C_{VCCB} = 1 \mu\text{F}$ ,  $V_{BAT} = 3.3\text{V}$ ,  $V_{CCA} = 1.8\text{V}$ ,  $T_A = 25^\circ\text{C}$ . (Continued)

### Power Supply Rejection Ratio ( $V_{BAT}=3.46\text{V}$ )

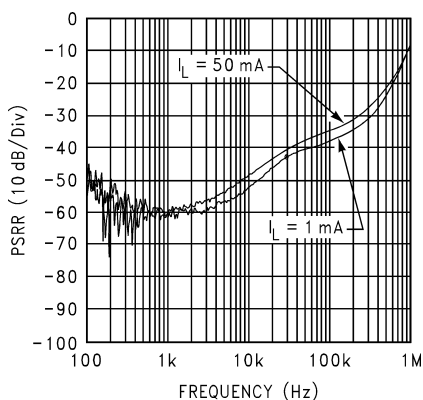

20039108

## Application Hints

### EXTERNAL CAPACITORS

Like any low-dropout regulator, the LP3928 requires external capacitors for regulator stability. The LP3928 is specifically designed for portable applications requiring minimum board space and smallest components. These capacitors must be correctly selected for good performance.

### INPUT CAPACITOR

An input capacitance of  $\cong 1 \mu\text{F}$  is required between the LP3928  $V_{BAT}$  pin and ground (the amount of the capacitance may be increased without limit).

This capacitor must be located a distance of not more than 1 cm from the  $V_{BAT}$  pin and returned to a clean analog ground. Any good quality ceramic, tantalum, or film capacitor may be used at the input.

**Important:** Tantalum capacitors can suffer catastrophic failures due to surge current when connected to a low-impedance source of power (like a battery or a very large capacitor). If a tantalum capacitor is used at the input, it must be guaranteed by the manufacturer to have a surge current rating sufficient for the application.

There are no requirements for the ESR on the input capacitor, but tolerance and temperature coefficient must be considered when selecting the capacitor to ensure the capacitance will be  $\cong 1 \mu\text{F}$  over the entire operating temperature range.

### FAST ON-TIME

The LP3928 utilizes a speed up circuitry to ramp up the internal  $V_{REF}$  voltage to its final value to achieve a fast output turn on time.

### CAPACITOR CHARACTERISTICS

The LP3928 is designed to work with ceramic capacitors on the output to take advantage of the benefits they offer: for capacitance values in the range of  $1 \mu\text{F}$  to  $4.7 \mu\text{F}$  range, ceramic capacitors are the smallest, least expensive and have the lowest ESR values (which makes them best for eliminating high frequency noise). The ESR of a typical  $1 \mu\text{F}$

ceramic capacitor is in the range of  $20 \text{ m}\Omega$  to  $40 \text{ m}\Omega$ , which easily meets the ESR requirement for stability by the LP3928.

The ceramic capacitor's capacitance can vary with temperature.

Most large value ceramic capacitors ( $\cong 2.2 \mu\text{F}$ ) are manufactured with Z5U or Y5V temperature characteristics, which results in the capacitance dropping by more than 50% as the temperature goes from  $25^\circ\text{C}$  to  $85^\circ\text{C}$ .

A better choice for temperature coefficient in ceramic capacitor is X7R, which holds the capacitance within  $\pm 15\%$ .

Tantalum capacitors are less desirable than ceramic for use as output capacitors because they are more expensive when comparing equivalent capacitance and voltage ratings in the  $1 \mu\text{F}$  to  $4.7 \mu\text{F}$  range.

Another important consideration is that tantalum capacitors have higher ESR values than equivalent size ceramics. This means that while it may be possible to find a tantalum capacitor with an ESR value within the stable range, it would have to be larger in capacitance (which means bigger and more costly) than a ceramic capacitor with the same ESR value. It should also be noted that the ESR of a typical tantalum will increase about 2:1 as the temperature goes from  $25^\circ\text{C}$  down to  $-40^\circ\text{C}$ , so some guard band must be allowed.

### OUTPUT CAPACITOR

The LP3928 is designed specifically to work with very small ceramic output capacitors, any ceramic capacitor (dielectric types Z5U, Y5V or X7R) in  $1.5 \mu\text{F}$  to  $22 \mu\text{F}$  range with  $5 \text{ m}\Omega$  to  $500 \text{ m}\Omega$  ESR range is suitable in the LP3928 application circuit.

It may also be possible to use tantalum or film capacitors at the output, but these are not as attractive for reasons of size and cost (see section Capacitor Characteristics).

The output capacitor must meet the requirement for minimum amount of capacitance and also have an ESR (Equivalent Series Resistance) value which is within a stable range.

The output capacitor should be placed as near to the  $V_{CCB}$  pin as possible.

## Application Hints (Continued)

### NO-LOAD STABILITY

The LDO of the LP3928 will remain stable and in regulation with no external load connected to the LDO output  $V_{CCB}$ . This is especially important in CMOS RAM keep-alive applications.

### LEVEL SHIFTER DIRECTION CONTROL AND LATCH CLOCK

The direction of the level shifter is set to  $Ax \rightarrow Bx$  by pulling the DIRx pin to high. The direction of each of the three channels can be set individually. In this mode a change at the LatchClk pin has no effect.

A low at the DIRx pin sets the direction to  $Bx \rightarrow Ax$ . If EN2 is set to high (enabling latch mode), a rising edge of LatchClk will update Ax depending on the level at Bx. A falling edge of LatchClk will not change Ax.

### MICRO SMD ASSEMBLY

For assembly recommendations of micro SMD package please refer to National Semiconductor Application Note AN-1112.

### MICRO SMD LIGHT SENSITIVITY

Exposing the micro SMD device to direct sunlight will cause misoperation of the device. Light sources such as Halogen lamps can effect electrical performance if brought near to the device.

The wavelengths which have most detrimental effect are reds and infra-reds, which means that the fluorescent lighting used inside most buildings has very little effect on performance.

A micro SMD test board was brought to within 1 cm of a fluorescent desk lamp and the effect on the regulated output voltage was negligible, showing a deviation of less than TBD from nominal.

### OPERATION MODES, EN1 AND EN2

The output of the LDO ( $V_{CCB}$ ) is turned off and the level shifter channels are set to a high Z state by pulling the enable input pins EN1 and EN2 low.

EN1=0 and EN2=1 turns the LDO on and the level shifter off.

EN1=1 and EN2=0 turns the LDO on and the latch of the level shifter is bypassed in B to A direction. The Latch Clock is not used in this mode. The LatchClk pin should not be left floating but actively terminated.

EN1=1 and EN2=1 turns the LDO on and activates the latch in B to A direction.

To assure proper operation, the signal source used to drive the EN input pins must be able to swing above and below the specified turn-on/off voltage thresholds listed in the Electrical Characteristics section under Level Shifter DC Voltage Levels.

Both pins, EN1 and EN2 must be actively terminated.

**Physical Dimensions** inches (millimeters) unless otherwise noted

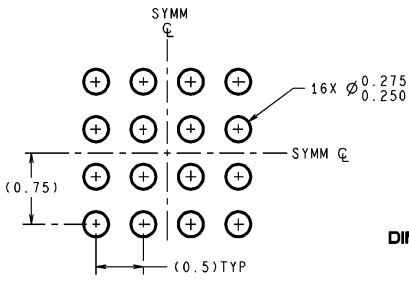

**DIMENSIONS ARE IN MILLIMETERS**

**LAND PATTERN RECOMMENDATION**

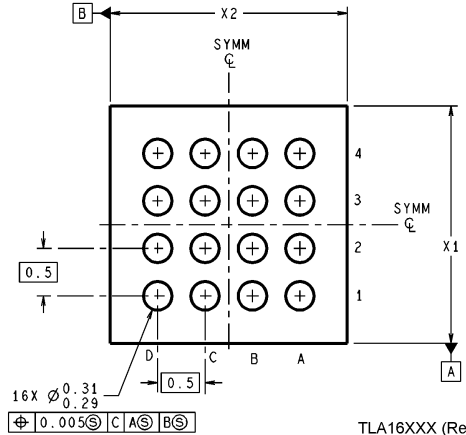
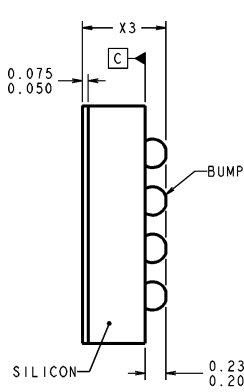
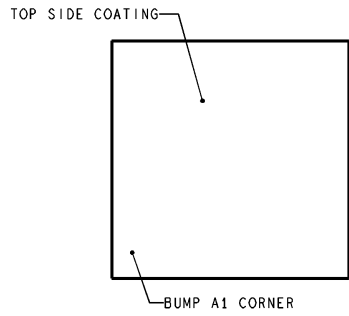

TLA16XXX (Rev A)

**micro SMD, 16 Bump**  
**NS Package Number TLA16AAA**  
**The Dimensions for X1, X2 and X3 are as follows:**  
**X1 = 1.996mm**  
**X2 = 1.996mm**  
**X3 = 0.600mm**

**LIFE SUPPORT POLICY**

NATIONAL'S PRODUCTS ARE NOT AUTHORIZED FOR USE AS CRITICAL COMPONENTS IN LIFE SUPPORT DEVICES OR SYSTEMS WITHOUT THE EXPRESS WRITTEN APPROVAL OF THE PRESIDENT AND GENERAL COUNSEL OF NATIONAL SEMICONDUCTOR CORPORATION. As used herein:

1. Life support devices or systems are devices or systems which, (a) are intended for surgical implant into the body, or (b) support or sustain life, and whose failure to perform when properly used in accordance with instructions for use provided in the labeling, can be reasonably expected to result in a significant injury to the user.
2. A critical component is any component of a life support device or system whose failure to perform can be reasonably expected to cause the failure of the life support device or system, or to affect its safety or effectiveness.



**National Semiconductor**  
**Americas Customer**  
**Support Center**  
 Email: new.feedback@nsc.com  
 Tel: 1-800-272-9959

**National Semiconductor**  
**Europe Customer Support Center**  
 Fax: +49 (0) 180-530 85 86  
 Email: europe.support@nsc.com  
 Deutsch Tel: +49 (0) 69 9508 6208  
 English Tel: +44 (0) 870 24 0 2171  
 Français Tel: +33 (0) 1 41 91 8790

**National Semiconductor**  
**Asia Pacific Customer**  
**Support Center**  
 Fax: 65-6250 4466  
 Email: ap.support@nsc.com  
 Tel: 65-6254 4466

**National Semiconductor**  
**Japan Customer Support Center**  
 Fax: 81-3-5639-7507  
 Email: nsj.crc@jksmtp.nsc.com  
 Tel: 81-3-5639-7560

www.national.com