

DESCRIPTION

The LX8817 is a dual channel positive-voltage linear regulator. This dual regulator has one fixed output coupled with an adjustable output. Each channel features low-dropout and high accuracy.

The LX8817 utilizes dual inputs that can be used as separate sources for the control and power sections. This configuration reduces power dissipation by operating the regulator near dropout ($V_{PWR} - V_{OUT} = V_{DO} = 0.6V @ 2.5A$) while providing sufficient operating headroom for the control logic.

The LX8817 provides designers with an efficient flexible power management solution, minimal printed circuit board area, and shorter design cycles.

Each channel can supply up to 2.5A independently with a regulator design optimized for system efficiency by consuming minimal ground current

and directing quiescent current to the load. The LX8817 features on-chip trimming of the internal voltage reference, enabling precise output voltages, typically $\pm 1\%$ of its specified value.

Power sequencing logic ensures proper startup regardless of the level of V_{CTRL} or V_{PWR} . The LX8817 outputs remain off while $V_{PWR} < 2.7V$.

Thermal and Short Circuit Current Protection are integrated on-chip and operate independently for each regulator output.

The LX8817 regulator is stable with a low-value output capacitor, typically $10\mu F$ tantalum or ceramic on the outputs, allowing designers flexibility in external component selection.

Linfinity's S-PAK power package offers maximum power dissipation and ease of assembly using surface mount technology.

KEY FEATURES

- Two Independent Regulated Outputs
- Accurate Output Voltages
- Max. Dropout of 0.6V at Rated Current
- Independent Thermal and Current Limit Protection
- Low Profile 7 Lead SMT Power Package
- Low Tolerance Line (0.2%) and Load (0.4%) Regulation
- Wide DC Supply Voltage of 3.0V to 10.0V
- Loop Stability Independent of Output Capacitor Type

APPLICATIONS/BENEFITS

- 3.3V to 2.5V/ADJ Linear Regulator
- Low Voltage Logic Supplies
- Active SCSI Terminators
- Battery Charging Circuits
- Instrumentation
- PC Peripherals

IMPORTANT: For the most current data, consult MICROSEMI's website: <http://www.microsemi.com>

PRODUCT HIGHLIGHT

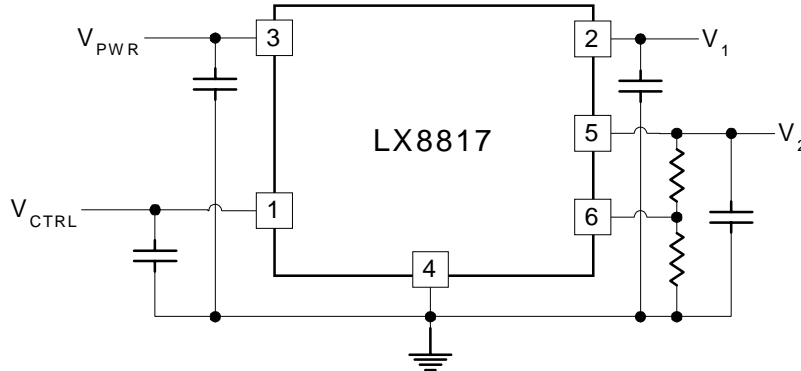

PACKAGE ORDER INFO

T_A (°C)	OUTPUT V_1	OUTPUT V_2	DF	Plastic S-PAK 7-PIN
0 to 125	2.5V	Adj		LX8817-2500CDF

Note: Available in Tape & Reel.
Append the letter "T" to the part number. (i.e. LX8817-xxxxC_T)

ABSOLUTE MAXIMUM RATINGS

Input Voltage (V_{CTRL} , V_{PWR})	13.5V
Load Current (Internally Limited)	3.0A
Power Dissipation.....	Internally Limited
Short-Circuit Protection.....	Indefinite
Operating Junction Temperature	150°C
Storage Temperature Range	-65°C to 150°C
Lead Temperature (Soldering 180 seconds)	235°C

Note: Exceeding these ratings could cause damage to the device. All voltages are with respect to Ground. Currents are positive into, negative out of specified terminal.

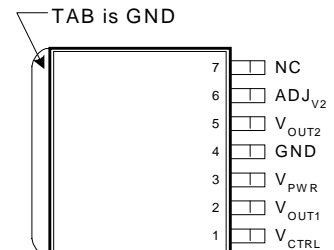
PACKAGE PIN OUT

DF PACKAGE
(Top View)

THERMAL DATA
DF Plastic S-PAK 7-PIN

THERMAL RESISTANCE-JUNCTION TO TAB, θ_{JT}	4.5°C/W
THERMAL RESISTANCE-JUNCTION TO AMBIENT, θ_{JA}	20°C/W

Junction Temperature Calculation: $T_J = T_A + (P_D \times \theta_{JA})$.

The θ_{JA} numbers are guidelines for the thermal performance of the device/pc-board system. All of the above assume no ambient airflow. θ_{JA} can vary from 10°C/W to > 30°C/W depending on mounting technique. (See Application Notes Section: Thermal considerations)

FUNCTIONAL PIN DESCRIPTION

PIN	NAME	DESCRIPTION
1	V_{CTRL}	Unregulated input voltage supply, provides bias for control circuitry, ($V_{CTRL} - V_{OUT}$) > 1V.
2	V_{OUT1}	Regulator #1 fixed output voltage.
3	V_{PWR}	Unregulated input voltage supply for power section. For proper operation: ($V_{PWR} - V_{OUT}$) > $V_{DROPOUT}$.
4	GND	Common terminal for ground reference, Tab of package is internally connected to this pin.
5	V_{OUT2}	Regulator #2 adjustable output.
6	ADJ _{V2}	Regulator #2 voltage feedback. Sets the output voltage for regulator #2 via an external resistor divider.
7	NC	Not used.

ELECTRICAL CHARACTERISTICS

Unless otherwise specified, the following specifications apply over the operating ambient temperature $0^{\circ}\text{C} \leq T_A \leq 135^{\circ}\text{C}$ except where otherwise noted and the following test conditions: $V_{\text{CTRL}} = 5\text{V}$, $V_{\text{PWR}} = 3.3\text{V}$, $I_{\text{OUT}} = 10\text{mA}$, $C_{1,2,3,4} = 10\mu\text{F}$ (Tantalum), and $T_J = T_A$ using low duty cycling methods.

Parameter	Symbol	Test Conditions	LX8817-xx00			Units
			Min	Typ	Max	
▶ FIXED OUTPUT						
Output Voltage • LX8815-2500	V_1	$I_1 = 10\text{mA}$, $T_J = 25^{\circ}\text{C}$ $5\text{mA} < I_1 < 2.5\text{A}$, $3.75\text{V} < V_{\text{CTRL}} < 8\text{V}$ $3\text{V} < V_{\text{PWR}} < 5.5\text{V}$	2.475 2.425	2.500 2.500	2.550 2.570	V
Line Regulation	$\Delta V_1(V_{\text{IN}})$	$3.3\text{V} < V_{\text{CTRL}} < 10\text{V}$, $3.3\text{V} < V_{\text{PWR}} < 5\text{V}$, $I_1 = 5\text{mA}$		1	5	mV
Load Regulation	$\Delta V_1(I_1)$	$5\text{mA} < I_1 < 2.5\text{A}$, $V_{\text{CTRL}} = 5\text{V}$, $V_{\text{PWR}} = 3.3\text{V}$		1	9	mV
Dropout Voltage (PWR)	$V_{\text{PWR}} - V_1$	$I_1 = 2.5\text{A}$, $\Delta V_1 = -2\%$ $I_1 = 2.0\text{A}$, $\Delta V_1 = -2\%$ $I_1 = 1.0\text{A}$, $\Delta V_1 = -2\%$		0.500 0.375 0.225	0.630 0.530 0.350	V
Current Limit	$I_1(\text{MAX})$		2.55	3.0		A
Minimum Load Current	I_1	Note 1		0	15	mA
▶ ADJUSTABLE OUTPUT						
Reference Voltage	V_2	$I_2 = 10\text{mA}$, $T_J = 25^{\circ}\text{C}$ $5\text{mA} < I_2 < 2.5\text{A}$, $3.0\text{V} < V_{\text{CTRL}} < 8\text{V}$ $2\text{V} < V_{\text{PWR}} < 5.5\text{V}$	1.225 1.213	1.250 1.250	1.275 1.288	V
Line Regulation	$\Delta V_2(V_{\text{IN}})$	$3\text{V} < V_{\text{CTRL}} < 10\text{V}$, $2\text{V} < V_{\text{PWR}} < 5.5\text{V}$, $I_2 = 5\text{mA}$		0.05	3	mV
Load Regulation	$\Delta V_2(I_2)$	$5\text{mA} < I_2 < 2.5\text{A}$, $V_{\text{CTRL}} = 5\text{V}$, $V_{\text{PWR}} = 3.3\text{V}$		1	7	mV
Dropout Voltage	$V_{\text{PWR}} - V_2$	$I_2 = 2.5\text{A}$, $\Delta V_2 = -2\%$ $I_2 = 2.0\text{A}$, $\Delta V_2 = -2\%$ $I_2 = 1.0\text{A}$, $\Delta V_2 = -2\%$		0.500 0.375 0.225	0.63 0.53 0.35	V
Current Limit	$I_2(\text{MAX})$		2.55	3.0		A
Minimum Load Current	I_2	Note 1		1	25	mA
Adjust Pin Bias Current	I_{ADJ}			1	5	μA
▶ ENTIRE REGULATOR						
Under Voltage Lockout		V_{PWR} Rising, $3.0\text{V} < V_{\text{CTRL}} = 10\text{V}$, Both Outputs High Impedance V_{CTRL} Rising, $3.0\text{V} < V_{\text{PWR}} = 10\text{V}$, Both Outputs High Impedance			2.5 2.5	V
Quiescent Current	I_Q	$I_1 = I_2 = 10\text{mA}$		1.8	10	mA
Ripple Rejection	PSRR	$f = 120\text{Hz}$, $T_J = 25^{\circ}\text{C}$	60	75		dB
RMS Output Noise		$10\text{Hz} < f < 10\text{kHz}$		0.003		$\%V_{\text{OUT}}$
Thermal Shutdown	T_{JSD}			160		$^{\circ}\text{C}$

Note 1: Minimum load current is defined as the amount of output current required to maintain regulation. Typically this current provides the bias to the external resistor divider network used to set the output voltage.

APPLICATION CIRCUIT/BLOCK DIAGRAM

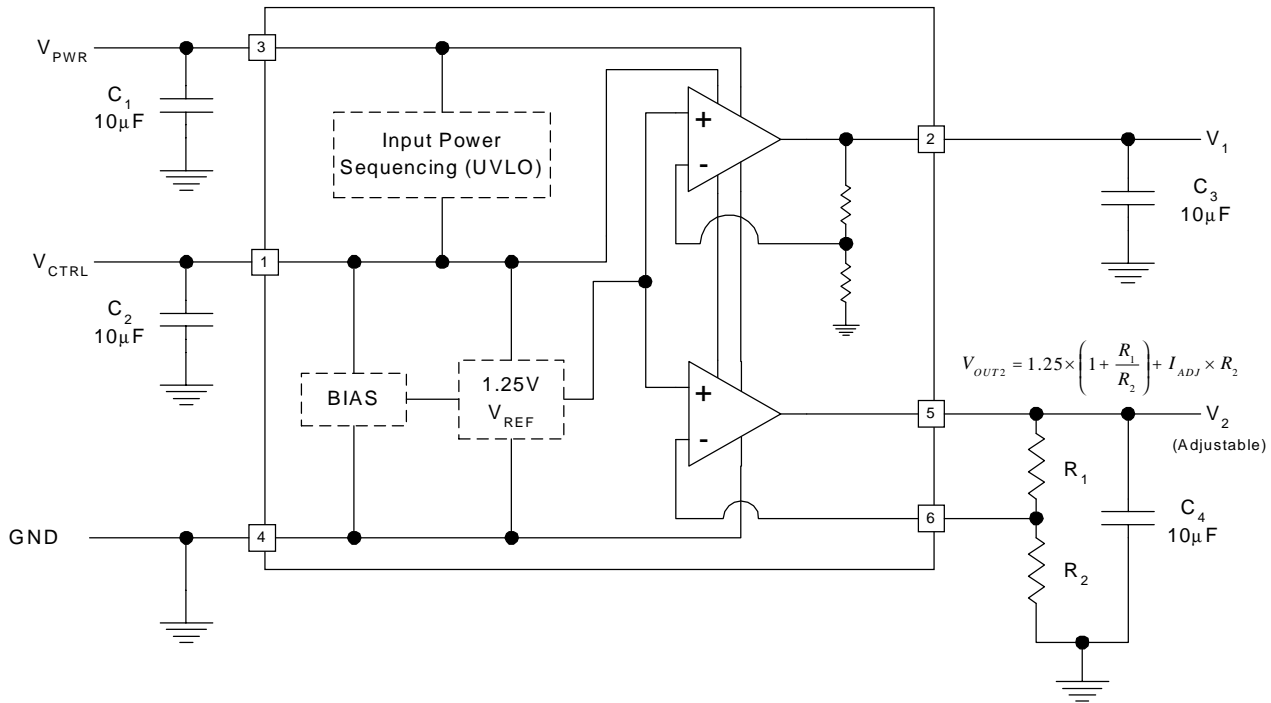

MECHANICAL DIMENSIONS

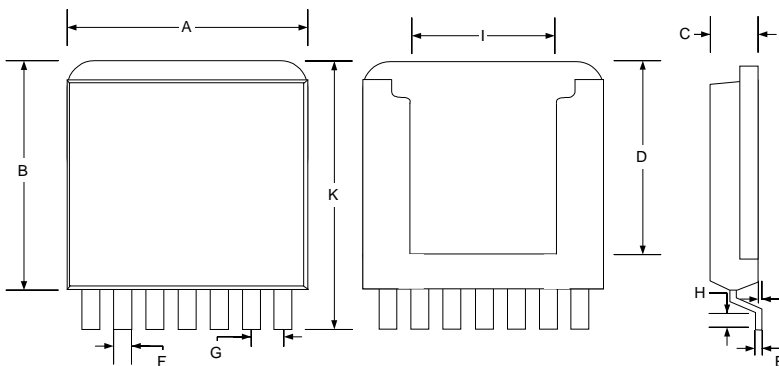

Dim	MILLIMETERS		INCHES	
	MIN	MAX	MIN	MAX
A	9.27	9.52	.365	.375
B	8.89	9.14	.350	.360
C	1.77	2.03	.070	.080
D	7.49	7.74	.295	.305
E	0.12	0.38	.005	.015
F	0.58	0.84	.023	.033
G	1.27 BSC		0.050 BSC	
H	0.79	1.04	.031	.041
I	4.31	6.86	.170	.270
J	0.03	0.13	.001	.005
K	10.41	10.67	.410	.420

Note:

1. Dimensions do not include mold flash or protrusions; these shall not exceed 0.155mm(.006") on any side. Lead dimension shall not include solder coverage.

Preliminary Data – Information contained in this document is pre-production data and is proprietary to Linfinity. It may not be modified in any way without the express written consent of Linfinity. Product referred to herein is offered in sample form only and Linfinity reserves the right to change or discontinue this proposed product at any time.