

PRELIMINARY

MITSUBISHI<AV COMMON>
M61018GP
 MOTOR DRIVER FOR CAMERA

DESCRIPTION

M61018GP is a semiconductor integrated circuit built-in motor driver for compact camera.
 All power transistors which have been used as external parts so far are built in by using minute bi-polar process ,so it contributes to reduction of the part cost and the miniaturization of the system .

FEATURES

- Built-in DC/DC converter (Presser type,TYP 5.0V)
- Built-in Regulator circuit for Auto Focus (Depressor type,TYP 4.1V)
- Built-in IRED drive circuit (TYP I_o=1A)
- Built-in DC motor driver circuit of 1.5CH

APPLICATION

Motor driver for compact camera etc.

RECOMMEND OPERATING CONDITION

Supply voltage range 1.8 to 3.5V

Rated supply voltage 3.0V

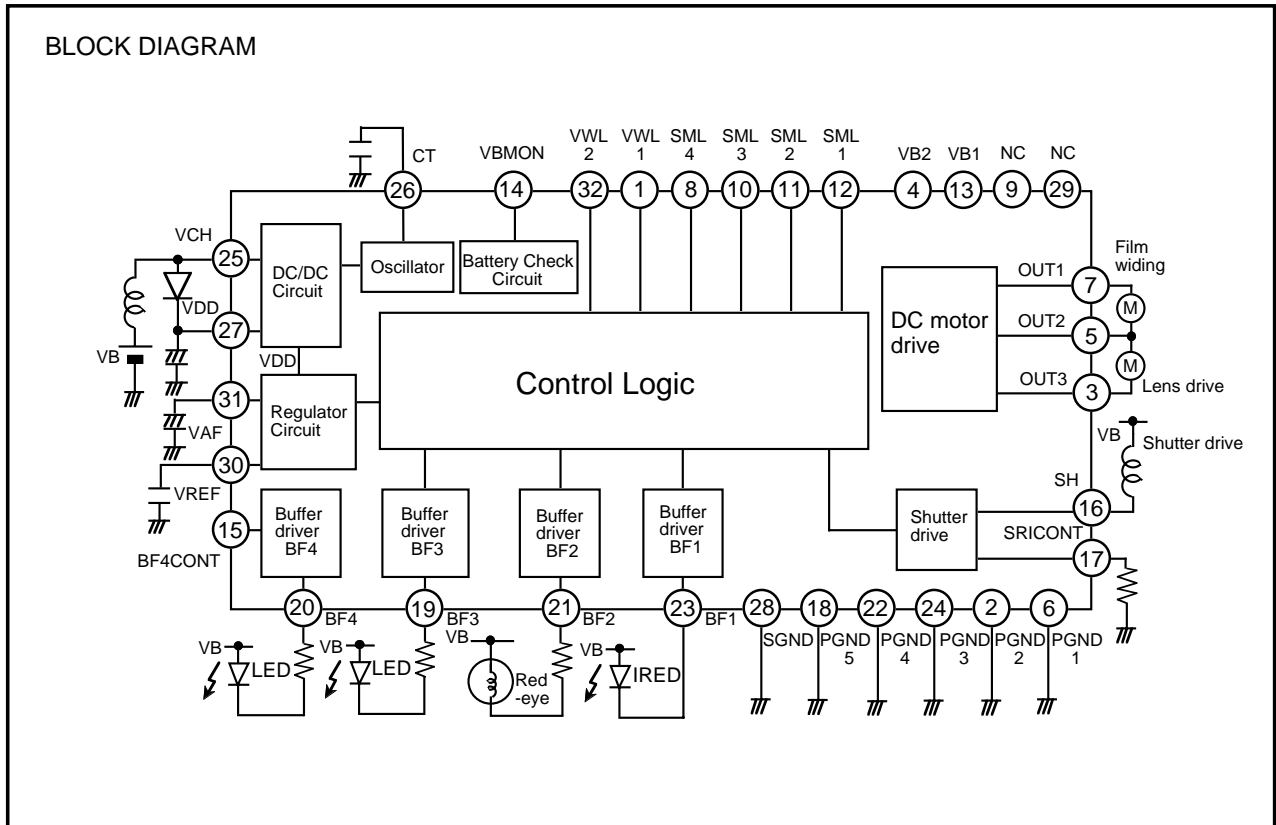
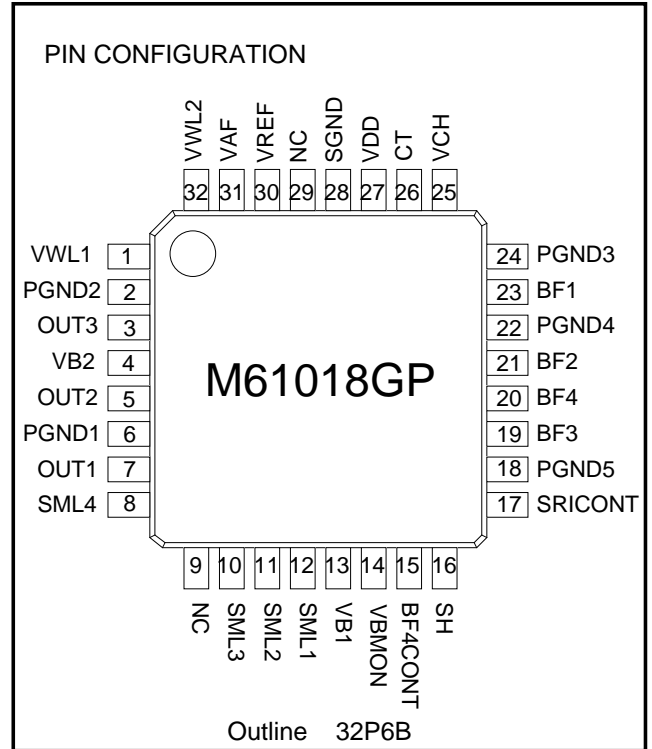

ABSOLUTE MAXIMUM RATINGS (Ta=25°C , unless noted)

Parameter	Symbol	Ratings	Unit	Remark
Supply voltage	VB	4.0	V	note1
Supply voltage	VDD	6.0	V	note1
Power dissipation	Pd	550	mW	Ta=25°C
Thermal derating	Kθ	4.4	mW/°C	Ta≥25°C
Pin input voltage	VIF	6.0	V	3,4,11,12,13,14,17pin
Another pin	VI/O	0 to VDD+0.3	V	note2
Operating temperature	Topr	- 20 to 60	°C	
Storage temperature	Tstg	- 40 to 150	°C	
Surge voltage	Vsurge	± 1000V over	V	C=100PF R=1.5K

note1 : As a principle , do not provide reversely.

note2 : As a principle . do not provide over supplv voltaae or under around voltaae.

THERMAL DERATING (MAXIMUM RATING)

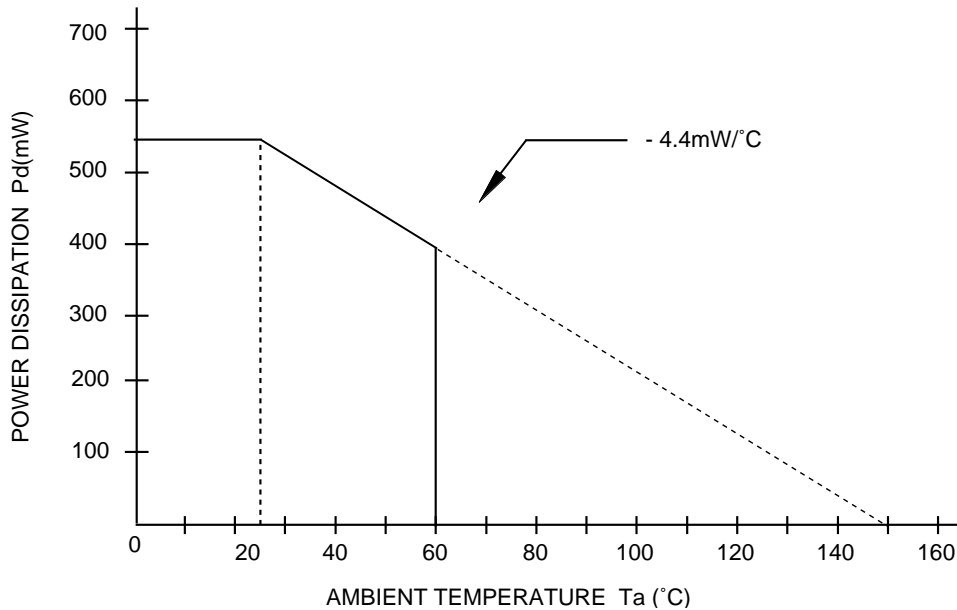

PRELIMINARY

MITSUBISHI<AV COMMON>
M61018GP
 MOTOR DRIVER FOR CAMERA

ELECTRICAL CHARACTERISTICS (Ta=25°C,VB=3.0V,unless otherwise noted)

Classification	Parameter	Symbol	Test condition	Limit			Unit	Note
				min	typ	max		
	Operating supply voltage range	VB		1.8	3.0	3.5	V	
Consuming current	While STAND BY consuming current	IB1	VWL1:H,VWL2:H	–	–	5.0	μA	
	While STAND BY consuming current	IDD1	VWL1:H,VWL2:H	–	–	5.0	μA	
	Usual consuming current	IDD2	Consuming current When driver don't operate (Operating only DC/DC converter)	–	5.0	10.0	mA	
DC/DC converter	Operating start voltage	Vstart	VB voltage	–	–	1.8	V	*1
	Operating stop voltage	Vstop	VB voltage	–	–	1.0	V	*1
	Oscillation frequency	fosc	C=330pF	35K	50K	65K	Hz	*1
	DUTY	duty		66	78	90	%	*1
	Output voltage	Vout	VDD voltage	4.5	5.0	5.5	V	*1
	Input stability	Vout1	VB=2.0 to 3.3V out=50mA	–	–	100	mV	*1
	Load stability	Vout2	VB=2.85V Iout=0 to 100mA	–	–	100	mV	*1
	Maximum output voltage	Iout	VB=2.85V Vout ≥ 4.5V	100	–	–	mA	*1
Regulator	Output voltage	VAF	VDD=4.5 to 5.5V IAF=50mA	3.90	4.10	4.30	V	
	Load stability	VAF	VDD=5V IAF=0 to 20mA	-10	–	10	mV	
	Ripple voltage	Vrip	VB=2.85V Vout ≥ 4.5V	0	–	10	mVp-p	
	Response time	TAF	CVAF=10μF CVREF=0.1μF	0		10	mS	
DC motor driver	Operating voltage	VB(DC motor)	VB voltage	1.6	–	3.5	V	
	Maximum output current	Iomax	t=10S	1.8	–	–	A	
	Continual maximum output current	Iocont		500	–	–	mA	
	Output saturation voltage	Vsat(DC motor)	Io=500mA Upper side+Lower side (saturation voltage total)	0	–	0.5	V	
	Spark killer diode forward voltage	VSF(DC motor)	Io=600mA	–	–	1.5	V	
	Overheat protection circuit operating temperature	Taohp		135	150	165	°C	
	Overheat protection hysteresis	Taohp		25	40	55	°C	
Shutter driver	Operating voltage	VB(shutter)	VB voltage	1.6	–	3.5	V	
	Simple output bias current	Isht1	1 Between SRICONT to GND	480	580	680	mA	
	Maximum output voltage	Isht2		700	–	–	mA	
	Output saturation voltage	Vsat(shutter)	Io=500mA SRICONT=0V	–	–	0.5	V	
	Spark killer diode forward voltage	VSF(shutter)	Io=600mA	–	–	1.5	V	

*1 L=47μH,CVDD=100 μF.

PRELIMINARY

MITSUBISHI<AV COMMON>
M61018GP
MOTOR DRIVER FOR CAMERA

ELECTRICAL CHARACTERISTICS(cont.) (Ta=25°C,VB=3.0V,unless otherwise noted)

Classification	Parameter	Symbol	Test condition	Limit			Unit	Note
				min	typ	max		
Buffer1	Operating voltage	VB(BF1)	VB voltage	1.6	–	3.5	V	
	Maximum output current	Ibf1	t=1S	2.0	–	–	A	
	Output saturation voltage	Vsat(BF1)	Io=1A	–	–	0.5	V	
Buffer2	Operating voltage	VB(BF2)	VB voltage	1.6	–	3.5	V	
	Maximum output current	Ibf2	t=1S	800	–	–	mA	
	Output saturation voltage	Vsat(BF2)	Io=500mA	–	–	0.5	V	
Buffer3	Operating voltage	VB(BF3)	VB voltage	1.6	–	3.5	V	
	Maximum output current	Ibf3	t=1S	800	–	–	mA	
	Output saturation voltage	Vsat(BF3)	Io=500mA	–	–	0.5	V	
Buffer4	Operating voltage	VB(BF4)	VB voltage	1.6	–	3.5	V	
	Maximum output current	Ibf4		150	–	–	mA	
	Output saturation voltage	Vsat(BF4)	Io =100mA	–	–	0.5	V	
	Input current	Ibf4cont	BF4CONT=0V	-70	-50	-30	μA	
	H input voltage	VinH		4.2	–	6.0	V	
	L input voltage	VinL		0	–	0.3	V	
BC	Output voltage	Vbc	VB=1.6 to 3.5V	$\frac{2}{3}VB - 0.15$	$\frac{2}{3}VB$	$\frac{2}{3}VB + 0.15$	V	

Interface

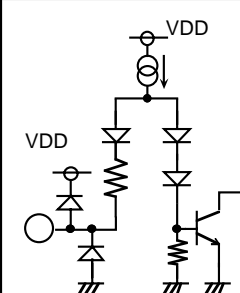
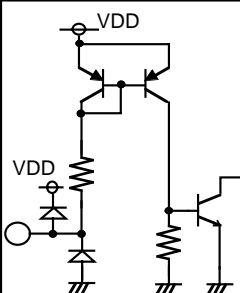
Terminal name	Circuit diagram	Parameter	Limit			Unit	Test condition and note
			Min.	Typ.	Max.		
SML1 SML2 SML3 SML4		"H" input voltage	2.0	—	6.0	V	
		"L" input voltage	0	—	0.3		
		"H" input current	—	—	3.0	μA	
		"L" input current	-60	-40	-20		
VWL1 VWL2		"H" input voltage	VDD-0.3	—	6.0	V	
		"L" input voltage	0	—	0.3		
		"H" input current	—	—	3.0	μA	
		"L" input current	-70	-45	-25		

VWL truth table

VWL1	VWL2	Output condition
H	H	Output OFF condition
H	L	Oscillation start (Oscillator ON) condition
L	L	DC/DC converter (5V)output condition
L	H	DC/DC&VAF regulator output condition VBMON output condition

*It needs the interval over 2mS in case of moving from the oscillation on to the output condition of DV/DC converter.

SML truth table

INPUT				MOTOR1	MOTOR2	Motor each output			Buffer each output				Note
SML1	SML2	SML3	SML4			OUT1	OUT2	OUT3	SH	BF1	BF2	BF3	
H	H	H	H	Stand-by	Stand-by	OFF	OFF	OFF	Stand-by	OFF	OFF	OFF	MOTOR1 control
H	H	H	L	Forward rotation	Stand-by	H	L	OFF	Stand-by	OFF	OFF	OFF	
H	H	L	H	Reverse rotation	Stand-by	L	H	OFF	Stand-by	OFF	OFF	OFF	
H	H	L	L	Brake	Stand-by	L	L	OFF	Stand-by	OFF	OFF	OFF	
H	L	H	H	Stand-by	Stand-by	OFF	OFF	OFF	Stand-by	OFF	OFF	OFF	MOTOR2 control
H	L	H	L	Stand-by	Forward rotation	OFF	H	L	Stand-by	OFF	OFF	OFF	
H	L	L	H	Stand-by	Reverse	OFF	L	H	Stand-by	OFF	OFF	OFF	
H	L	L	L	Stand-by	Brake	OFF	L	L	Stand-by	OFF	OFF	OFF	
L	H	H	H	Stand-by	Stand-by	OFF	OFF	OFF	Stand-by	OFF	OFF	OFF	Shutter control
L	H	H	L	Stand-by	Stand-by	OFF	OFF	OFF	ON	OFF	OFF	OFF	
L	H	L	H	Stand-by	Stand-by	OFF	OFF	OFF	Stand-by	ON	OFF	OFF	BF1
L	H	L	L	Stand-by	Stand-by	OFF	OFF	OFF	ON	ON	OFF	OFF	Shutter+BF1
L	L	H	H	Stand-by	Stand-by	OFF	OFF	OFF	Stand-by	OFF	OFF	OFF	
L	L	H	L	Stand-by	Stand-by	OFF	OFF	OFF	Stand-by	OFF	ON	OFF	BF2
L	L	L	H	Stand-by	Stand-by	OFF	OFF	OFF	Stand-by	OFF	OFF	ON	BF3
L	L	L	L	Stand-by	Stand-by	OFF	OFF	OFF	Stand-by	OFF	ON	ON	

*Please pass through the Brake or Stand-by mode by all means in case of moving from forward rotation to Reverse rotation or from Reverse rotation to forward rotation by the motor control.

(ex.)Forward rotation --> Brake --> Reverse rotation, Reverse rotation-->Stand-by --> Forward rotation

BF4 truth table

Input	Output
BF4CONT	BF4
H	OFF
L	L

Sequence Time chart example

Input signal

VB

VWL1

VWL2

Output signal

VDD

VAF

IC control content

Oscillator
Control SW

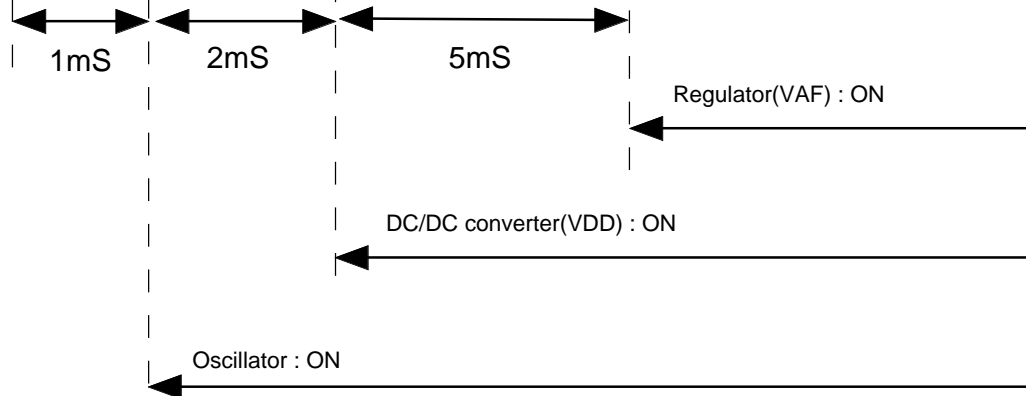

Note regarding these materials

- These materials are intended as reference to assist our customers in the selection of the Mitsubishi semiconductor product best suited to the customer's application; they do not convey any license under any intellectual property rights, or any other rights, belonging to Mitsubishi Electric Corporation or a third party.
- Mitsubishi Electric Corporation assumes no responsibility for any damage, or infringement of any third-party's right, originating in the use of any product data, diagrams, charts of circuit application examples contained in these materials.
- All information contained in these materials, including product data, diagrams and charts, represent information on products at the time of publication of these materials, and are subject to change by Mitsubishi Electric Corporation without notice due to product improvements or other reasons. It is therefore recommended that customers contact Mitsubishi Electric Corporation or an authorized Mitsubishi Semiconductor product distributor for the latest product information before purchasing a product listed herein.
- Mitsubishi Electric Corporation semiconductors are not designed or manufactured for use in a device or system that is used under circumstances in which human life is potentially at stake. Please contact Mitsubishi Electric Corporation or an authorized Mitsubishi Semiconductor product distributor when considering the use of a product contained herein for special applications, such as apparatus or systems for transportation, vehicular, medical, aerospace, nuclear repeater use.
- The prior written approval of Mitsubishi Electric Corporation is necessary to reprint or reproduce in whole or in part these materials.
- If these products or technologies are subject to the Japanese export control restrictions, they must be exported under license from the Japanese government and cannot be imported into a country other than the approved destination. Any diversion or reexport contrary to the export control laws and regulations of Japan and/or the country of destination is prohibited.
- Please contact Mitsubishi Electric Corporation or an authorized Mitsubishi Semiconductor product distributor for further details on these materials or the products contained therein.