

M62050P,FP

3V supply SYSTEM RESET with watchdog timer

GENERAL DESCRIPTION

M62050P/FP is a voltage threshold detector designed for detection of 3V supply voltage and generation of a system reset pulse. It is suitable for microcontroller systems.

The IC, a supervisor of the MCU operations, dissipates low current of 0.6mA (typ) during normal operations of the MCU systems.

It has 2 selectable threshold voltages, which allows applying it to a high precision system design.

FEATURES

- Watchdog timer (supervisor for 2 system voltages)
- Power-on reset timer
- Low current consumption 0.6mA (typ) at Vcc = 3V
- Wide supply voltage range Vcc = 7V (max)

APPLICATION

- Supervisor for microcontroller systems

RECOMMENDED OPERATING CONDITION

- Supply voltage range 2V ~ 4V

PIN CONFIGURATION(TOP VIEW)

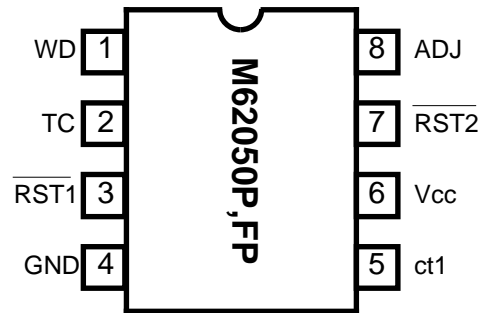

OUTLINE

8P4(P)
8P2S-A(FP)

BLOCK DIAGRAM

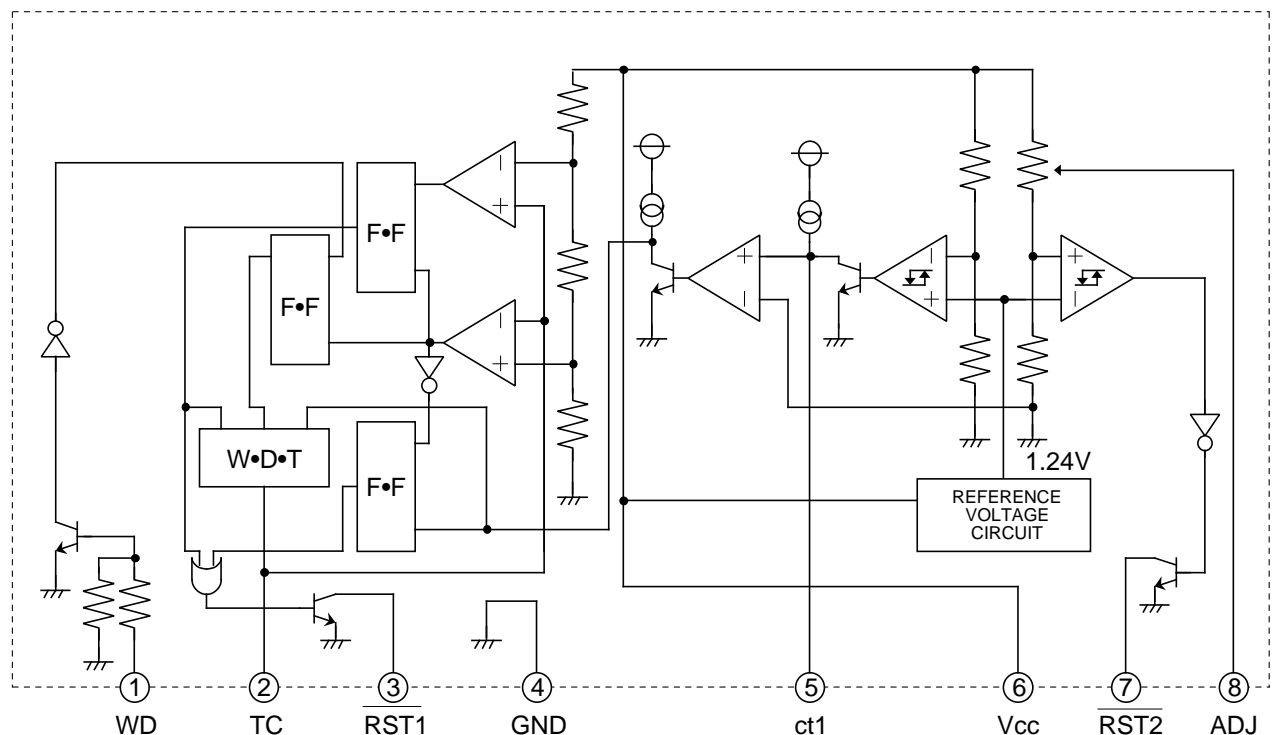

M62050P,FP

3V supply SYSTEM RESET with watchdog timer

Terminal functional description

PIN No.	symbol	Terminal functional description
①	W D	Input for watchdog timer
②	T C	Time set for reset timer and watchdog timer
③	$\overline{\text{RST1}}$	When abnormal signaling is input into WD terminal, it generates reset signal.
④	GND	GND
⑤	ct1	Detection voltage adjustment for WD input
⑥	Vcc	Power supply
⑦	$\overline{\text{RST2}}$	When power supply voltage became abnormal, it generates reset signal.
⑧	ADJ	Selection between 2 detection voltages

ABSOLUTE MAXIMUM RATING

symbol	Parameter	Ratings	Units
Vcc	Power supply voltage	15	V
VIN	Input voltage	-0.3 ~ 5	V
VOUT	Output voltage	15	V
IOUT	Output current	10	mA
Pd	Internal power dissipation	625	mW
K θ	Heat reduction rate	4.40	mW/°C
Topr	Operating ambient temperature	-20 ~ +75	°C
Tstg	Storage temperature	-55 ~ +125	°C

M62050P,FP

3V supply SYSTEM RESET with watchdog timer

ELECTRICAL CHARACTERISTIC (Ta=25 °C, VCC=3V, unless otherwise noted)

(1) DC characteristics

Symbol	Parameter	Terminal	Measurement condition	Ratings			Unit
				MIN	TYP	MAX	
IWD	WD input current	WD	VIN=3V	0.06	0.15	0.25	mA
VIH	WD input voltage	WD		1.5		3.00	V
VIL				-0.3		0.80	V
IOUT	TC output current	TC	VIN=0.9V			-0.10	μA
IIN	TC input current	TC	VOUT=2.5V		2.50		mA
VTH3(H)	Watchdog timer threshold voltage	TC			2.00		V
VTH3(L)					1.00		V
VOL	Output voltage	RST1	IOUT=1mA		0.20	0.50	V
Ileak	Output leakage current	RST2	VOUT=4V			5.00	μA
VTH1(H)	Vcc detection voltage(1)	VCC1		2.13	2.25	2.38	V
VTH1(L)				2.10	2.20	2.30	V
TH1				0.03	0.05	0.08	V
VTH2(H)	Vcc detection voltage(2)	VCC2	ADJ Terminal=OPEN	2.43	2.55	2.68	V
			ADJ Terminal=Vcc				
VTH2(L)			ADJ Terminal=OPEN	2.40	2.50	2.60	V
			ADJ Terminal=Vcc				
VTH2				0.03	0.05	0.08	V
RST1	RST1 ON voltage	RST1	VCC=1.2V,RL=3k			0.5	V
RST2	RST2 ON voltage	RST2	VCC=1.2V,RL=3k			0.5	V
ICC	Circuit current	VCC			0.5	1.0	mA

(2) AC characteristics

Symbol	Parameter	Terminal	Measurement condition	Ratings			Unit
				MIN	TYP	MAX	
TWD	Watchdog timer	RST1			1.1CR1		s
			C=0.1μF,R1=10k	0.5	1.1	1.7	ms
tRST(1)	Reset Timer(1)	RST1			0.5CR1		s
			C=0.1μF,R1=10k	0.2	0.50	1.1	ms
tRST(2)	Reset Timer(2)	RST1	R1=10k		830C		s
			C=0.1μF,R1=10k	40	83	220	μs
tWDIN	Input pulse duration	WD		3			μs
td1	Propagation delay	RST1			10		μs
td2		RST2			5		μs

M62050P,FP

3V supply SYSTEM RESET with watchdog timer

Timing chart

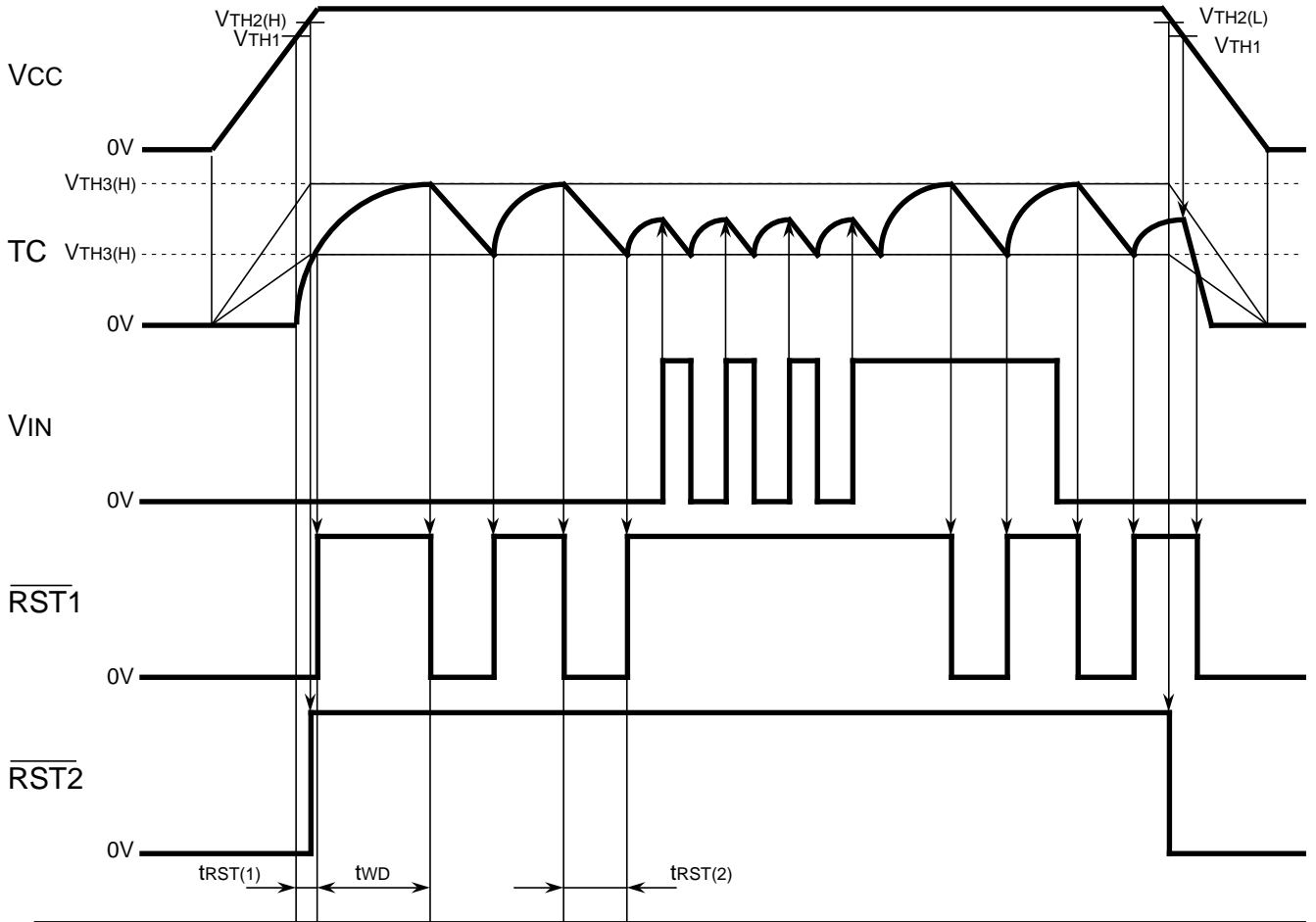

Application circuitry example

