

MAS9281

IC FOR 10.00 – 60.00 MHz XO

This is advance information on a new product under development. Micro Analog Systems Oy reserves the right to make any changes without notice.

Preliminary

- Low Cost
- Divider Option up to $f_o/512$
- Wide Supply Voltage Range
- CMOS Output
- Very High Level of Integration
- Very Low Phase Noise
- Output Three-State Function

DESCRIPTION

MAS9281 is an integrated circuit well suited to make fundamental crystal oscillator (XO): only one additional component, a crystal is needed.

MAS9281 includes oscillator and output buffer circuits.

FEATURES

- Very small size
- Minimum current draw
- Stand-by functions: Output high impedance, but oscillator running. Output high impedance and oscillator stop
- Wide operating temperature range
- Phase noise < -130 dBc/Hz at 1 kHz offset
- CMOS output

APPLICATIONS

- XO for data terminals
- XO for telecommunication applications
- XO for computer application

BLOCK DIAGRAM

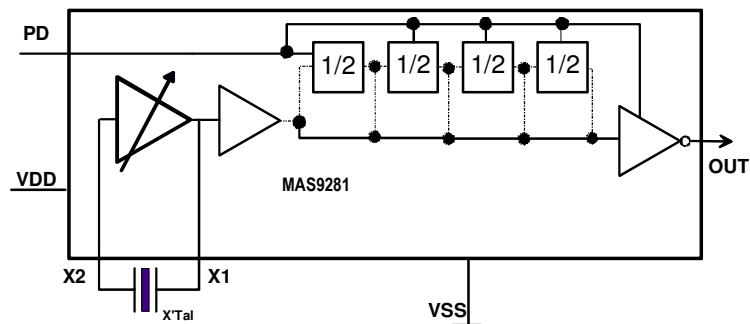

ABSOLUTE MAXIMUM RATINGS

Parameter	Symbol	Min	Max	Unit	Note
Supply Voltage	$V_{DD} - V_{SS}$	-0.3	6.0	V	
Input Voltage	V_{IN}	$V_{SS} - 0.3$	$V_{DD} + 0.3$	V	
Power Dissipation	P_{MAX}		120	mW	
Operating Temperature	T_{OP}	-40	85	°C	
Storage Temperature	T_{ST}	-55	150	°C	

RECOMMENDED OPERATION CONDITIONS

Parameter	Symbol	Conditions	Min	Typ	Max	Unit	Note
Supply Voltage	V_{DD}		2.4	2.8	5.5	V	1)
Crystal Load Capacitance MAS9281AN, -AP, -AQ, -AR, -AS, -AT, MAS9281A0, -A1, -A2, -A3, -A4 MAS9281AG -AH, -AJ, -AK, -AL MAS9281AA, -AB, -AC, -AD, -AE	C_L			14.5 14.5 11 9			2)

Note 1: If $V_{DD} = 5V$, it is recommended to connect 1nF capacitor to Vdd pin.

Note 2: For other load capacitance options contact to Micro Analog Systems Oy.

ELECTRICAL CHARACTERISTICS FOR 3V SUPPLY VOLTAGE

$T_A = -40^{\circ}C$ to $+85^{\circ}C$, typical values at $T_A = +27^{\circ}C$, $V_{DD} = 2.7V... 3.3V$, $f_o = 30$ MHz, Output Load = 15 pF, unless otherwise specified.

Parameter	Symbol	Min	Typ	Max	Unit	Note
Output Load			15	50	pF	
Crystal Frequency Range when Output Load is Maximum 30pF	f_o	10.00		60.00	MHz	Note 1
Crystal Frequency Range when Output Load is Maximum 50pF	f_o	10.00		40.00	MHz	
Supply Current MAS9281 (f_o) MAS9281 ($f_o/2$) MAS9281 ($f_o/4$) MAS9281 ($f_o/8$) MAS9281 ($f_o/16$) MAS9281 ($f_o/512$)	I_{DD}		5.7 4.5 4.1 3.9 3.7 3.5		mA	See fig. 2
Output Voltage Range			$V_{DD} \pm 0.5$		Vpp	
Rise and Fall Time			3	4	ns	
Start-up Time	T_{START}		2		ms	
Output Symmetry		45	48-52	55	%	
Tri State Output Buffer OFF State ON State	PD	0 1.6		0.55 V_{DD}	V	
Power Down High Level Output Voltage: $I_{OH} = 5.2$ mA, $V_{DD} = 3V$ (Test measurement, see fig. 1, p. 5)	V_{OH}		2.7		V	
PD Pull-up Resistance (Design value)	Rup1		900k		ohm	

Note1: MAS9281AN – MAS9281AT and MAS9281A0 – MAS9281A4 maximum frequency is 44MHz.

ELECTRICAL CHARACTERISTICS FOR 5V SUPPLY VOLTAGE

 T_A = -40°C to +85°C, typical values at T_A = +27°C, V_{DD} = 4.5V... 5V, f_o = 30 MHz, Output Load = 15 pF, unless otherwise specified.

Parameter	Symbol	Min	Typ	Max	Unit	Note
Output Load			15	50	pF	
Crystal Frequency Range when Output Load is Maximum 30pF	f _o	10.00		60.00	MHz	Note 1
Crystal Frequency Range when Output Load is Maximum 50pF	f _o	10.00		40.00	MHz	
Supply Current MAS9281 (f _o) MAS9281 (f _o /2) MAS9281 (f _o /4) MAS9281 (f _o /8) MAS9281 (f _o /16) MAS9281 (f _o /512)	I _{DD}		11.3 8.0 7.7 7.6 7.3 7.1		mA	See fig. 2
Output Voltage Range			V _{DD} ± 0.5		V _{pp}	
Rise and Fall Time			3	4	ns	
Start-up Time	T _{START}		2		ms	
Output Symmetry		45	48-52	55	%	
Tri State Output Buffer OFF State ON State	PD	0 1.6		0.55 V _{DD}	V	
Power Down High Level Output Voltage: I _{oh} =16 mA, V _{DD} = 5V (Test measurement, see fig. 1, p. 5)	V _{OH}		4.7		V	
PD Pull-up resistance Design value	R _{up1}		900k		ohm	

Note1: MAS9281AN – MAS9281AT and MAS9281A0 – MAS9281A4 maximum frequency is 44MHz

PIN DESCRIPTION

Pin Description	Symbol	x-coordinate	y-coordinate
Power Down	PD	146	140
Crystal Oscillator Output	X2	312	140
Crystal Oscillator Input	X1	553	140
Power Supply Ground	VSS	695	140
Power Supply Voltage	VDD	178	826
Buffer Output	OUT	597	826

Note: Because the substrate of the die is internally connected to GND, the die has to be connected to GND or left floating. Please make sure that GND is the first pad to be bonded. Pick-and-place and all component assembly are recommended to be performed in ESD protected area.

Note: Pad coordinates are measured from the left bottom corner of the chip to the center of the pads. The coordinates may vary depending on sawing width and location, however, distances between pads are accurate.

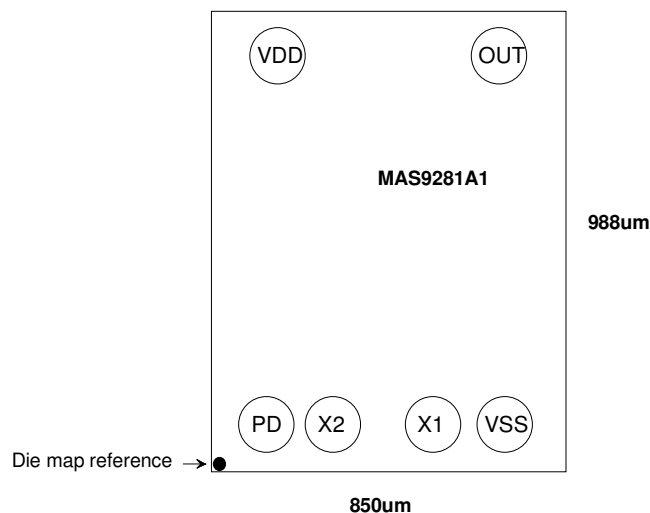
IC OUTLINES

Note: Die map reference is the actual left bottom corner of the sawn chip.

SERIES CONFIGURATION

Product Code	Output Frequency	Crystal Load (pF)	Output Load (pF)	Output Duty Level	Power Down Function	Frequency Range (MHz)
MAS9281AA	f_o	9	15	CMOS	Yes	10 - 60
MAS9281AB	$f_o/2$	9	15	CMOS	Yes	10 - 60
MAS9281AC	$f_o/4$	9	15	CMOS	Yes	10 - 60
MAS9281AD	$f_o/8$	9	15	CMOS	Yes	10 - 60
MAS9281AE	$f_o/16$	9	15	CMOS	Yes	10 - 60
MAS9281AG	f_o	11	15	CMOS	Yes	10 - 60
MAS9281AH	$f_o/2$	11	15	CMOS	Yes	10 - 60
MAS9281AJ	$f_o/4$	11	15	CMOS	Yes	10 - 60
MAS9281AK	$f_o/8$	11	15	CMOS	Yes	10 - 60
MAS9281AL	$f_o/16$	11	15	CMOS	Yes	10 - 60
MAS9281AN	f_o	14.5	15	CMOS	Yes	10 - 44
MAS9281AP	$f_o/2$	14.5	15	CMOS	Yes	10 - 44
MAS9281AQ	$f_o/4$	14.5	15	CMOS	Yes	10 - 44
MAS9281AR	$f_o/8$	14.5	15	CMOS	Yes	10 - 44
MAS9281AS	$f_o/16$	14.5	15	CMOS	Yes	10 - 44
MAS9281AT	$f_o/512$	14.5	15	CMOS	Yes	10 - 44
MAS9281A0	f_o	14.5	15	CMOS	Yes	10 - 44
MAS9281A1	$f_o/2$	14.5	15	CMOS	Yes	10 - 44
MAS9281A2	$f_o/4$	14.5	15	CMOS	Yes	10 - 44
MAS9281A3	$f_o/8$	14.5	15	CMOS	Yes	10 - 44
MAS9281A4	$f_o/16$	14.5	15	CMOS	Yes	10 - 44

APPLICATION INFORMATION

Version	PD pin	Output	Oscillator
AA, AB, AC, AD, AE, AG, AH, AJ, AK, AL, AN, AP, AQ, AR, AS, AT	HIGH	Normal Operation	Normal Operation
	LOW	High Impedance	Stopped
	Floating	Normal Operation	Normal Operation
A0, A1, A2, A3, A4	HIGH	Normal Operation	Normal Operation
	LOW	High Impedance	Normal Operation
	Floating	Normal Operation	Normal Operation

Figure 1

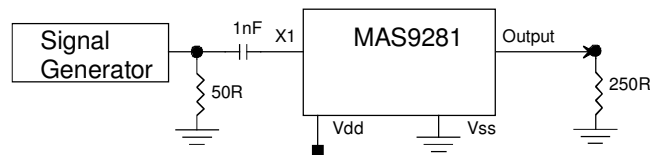
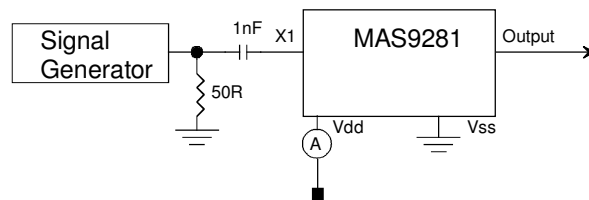

Figure 2



ORDERING INFORMATION

Product Code	Output Frequency	Crystal Load (pF)	Wafer thickness	Comments
MAS9281AATG00	f_o	9	215 μm	Tested, wafer
MAS9281ABTG00	$f_o/2$	9	215 μm	Tested wafer
MAS9281ACTG00	$f_o/4$	9	215 μm	Tested wafer
MAS9281ADTG00	$f_o/8$	9	215 μm	Tested wafer
MAS9281AETG00	$f_o/16$	9	215 μm	Tested wafer
MAS9281AGTG00	f_o	11	215 μm	Tested wafer
MAS9281AHTG00	$f_o/2$	11	215 μm	Tested wafer
MAS9281AJTG00	$f_o/4$	11	215 μm	Tested wafer
MAS9281AKTG00	$f_o/8$	11	215 μm	Tested wafer
MAS9281ALTG00	$f_o/16$	11	215 μm	Tested wafer
MAS9281ANTG00	f_o	14.5	215 μm	Tested wafer
MAS9281APTG00	$f_o/2$	14.5	215 μm	Tested wafer
MAS9281AQTG00	$f_o/4$	14.5	215 μm	Tested wafer
MAS9281ARTG00	$f_o/8$	14.5	215 μm	Tested wafer
MAS9281ASTG00	$f_o/16$	14.5	215 μm	Tested wafer
MAS9281ATTG00	$f_o/512$	14.5	215 μm	Tested wafer
MAS9281A0TG00	f_o	14.5	215 μm	Tested wafer
MAS9281A1TG00	$f_o/2$	14.5	215 μm	Tested wafer
MAS9281A2TG00	$f_o/4$	14.5	215 μm	Tested wafer
MAS9281A3TG00	$f_o/8$	14.5	215 μm	Tested wafer
MAS9281A4TG00	$f_o/16$	14.5	215 μm	Tested wafer

For product definitions see Application Information on page 5.

Contact Micro Analog Systems Oy for other wafer thickness options.

LOCAL DISTRIBUTOR

--

MICRO ANALOG SYSTEMS OY CONTACTS

Micro Analog Systems Oy Kamreerintie 2, P.O. Box 51 FIN-02771 Espoo, FINLAND	Tel. +358 9 80 521 Fax +358 9 805 3213 http://www.mas-oy.com
------------------------------------------------------------------------------------	--------------------------------------------------------------------------------------------------------

NOTICE

Micro Analog Systems Oy reserves the right to make changes to the products contained in this data sheet in order to improve the design or performance and to supply the best possible products. Micro Analog Systems Oy assumes no responsibility for the use of any circuits shown in this data sheet, conveys no license under any patent or other rights unless otherwise specified in this data sheet, and makes no claim that the circuits are free from patent infringement. Applications for any devices shown in this data sheet are for illustration only and Micro Analog Systems Oy makes no claim or warranty that such applications will be suitable for the use specified without further testing or modification.