

# MAS9285

## IC FOR XO TRIMMING

- Very Low Power
- Wide Trimming Range
- Wide Supply Voltage Range
- Very High Level of Integration
- Electrically Trimmable
- Low Cost

### DESCRIPTION

MAS9285 is capacitive digital to analog converter integrated circuit well suited to make initial offset trimming of the crystal oscillator. The trimming is

done by a serial bus and the calibration information is stored in an internal PROM.

### FEATURES

- Very small size
- Minimum current draw
- Wide operating temperature range

### APPLICATIONS

- OCXO
- All Crystal Oscillators

### BLOCK DIAGRAM

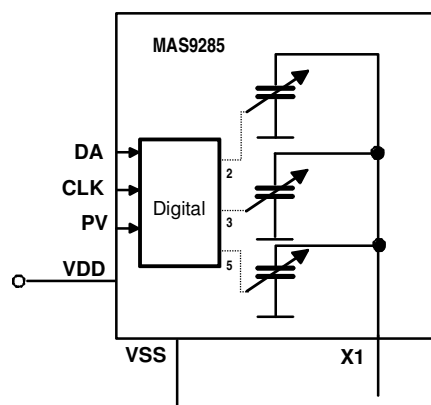

Figure 1. Block diagram of MAS9285.

## PIN DESCRIPTION

Pin Description	Symbol	x-coordinate	y-coordinate	Note
Serial Bus Data Input	DA	192	152	
Serial Bus Clock Input	CLK	425	152	
Programming Input	PV	656	158	
Power Supply Voltage	VDD	161	855	
Power Supply Ground	VSS	368	855	
CDAC Output with Bias Option	X1	629	871	

**Note:** Because the substrate of the die is internally connected to VDD, the die has to be connected to VDD or left floating. Please make sure that VDD is the first pad to be bonded. Pick-and-place and all component assembly are recommended to be performed in ESD protected area.

**Note:** Pad coordinates measured from the left bottom corner of the chip to the center of the pads. The coordinates may vary depending on sawing width and location, however, distances between pads are accurate.

## ABSOLUTE MAXIMUM RATINGS

Parameter	Symbol	Min	Max	Unit	Note
Supply Voltage	$V_{DD} - V_{SS}$	-0.3	6.0	V	
Input Voltage	$V_{IN}$	$V_{SS} - 0.3$	$V_{DD} + 0.3$	V	1)
Power Dissipation	$P_{MAX}$		100	mW	
Storage Temperature	$T_{ST}$	-55	150	°C	

**Note:** Not valid for programming pin PV

## RECOMMENDED OPERATION CONDITIONS

Parameter	Symbol	Conditions	Min	Typ	Max	Unit
Supply Voltage	$V_{DD}$		2.5	2.8	5.5	V
Supply Current	$I_{CC}$	Vdd = 3.3 Volt		7	50	μA
Operable Temperature	$T_C$		-40		+85	°C

## ELECTRICAL CHARACTERISTICS

(recommended operation conditions)

Parameter	Symbol	Min	Typ	Max	Unit	Note
Operation Frequency				200	MHz	

## IC OUTLINES

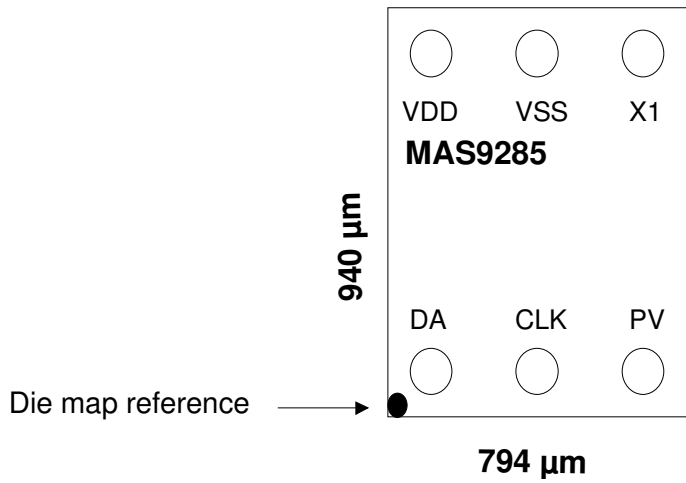

Figure 2. IC outline of MAS9285.

**Note 1:** MAS9285 pads are round with 80 μm diameter at opening.

**Note 2:** Pins PV, CLK and DA must not be connected in XO module end-user application.

## APPLICATION

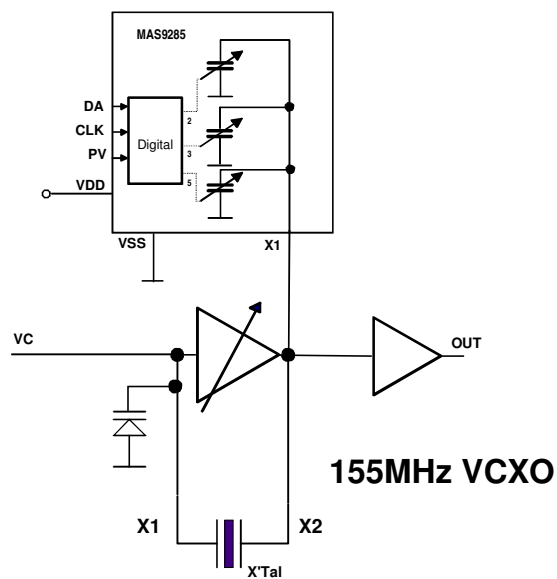
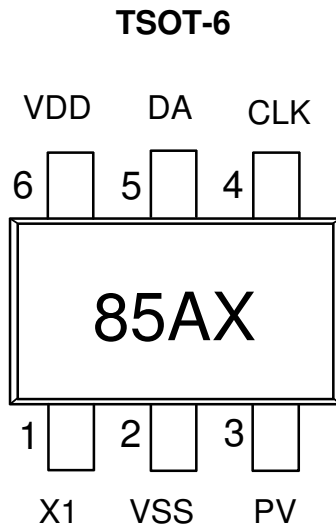

Figure 3. Typical application for MAS9285

**PIN CONFIGURATION (TSOT-6)**



85AX = Product version (MAS9285AX, where x = number)

**PIN DESCRIPTION (TSOT-6)**

Pin Name	Pin Number in TSOT-6	Type	Function
X1	1	O	CDAC Output with Bias Option
VSS	2	G	Power Supply Ground
PV	3	I	Programming Input
CLK	4	I	Serial Bus Clock Input
DA	5	I	Serial Bus Data Input
VDD	6	P	Power Supply Voltage

G = Ground, I = Input, O = Output, P = Power

**PIN CONFIGURATION (QFN-6)**

**QFN-6**

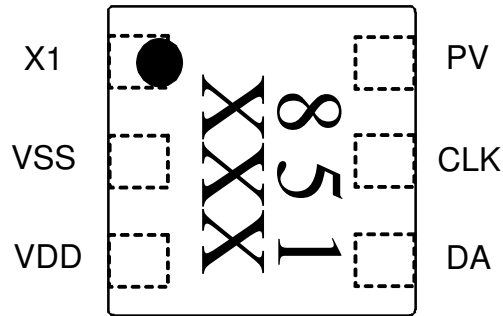

851 = Product version (MAS9285A1)  
XXX = MAS lot number (3 last digit)

**PIN DESCRIPTION (QFN-6)**

Pin Name	Pin Number in TSOT-6	Type	Function
X1	1	O	CDAC Output with Bias Option
VSS	2	G	Power Supply Ground
VDD	3	I	Power Supply Voltage
DA	4	I	Serial Bus Data Input
CLK	5	I	Serial Bus Clock Input
PV	6	P	Programming Input

G = Ground, I = Input, O = Output, P = Power

Exposed pad\* can be connected to ground or left floating  
\* see package outline information on page 8

**PACKAGE OUTLINE (TSOT-6)**

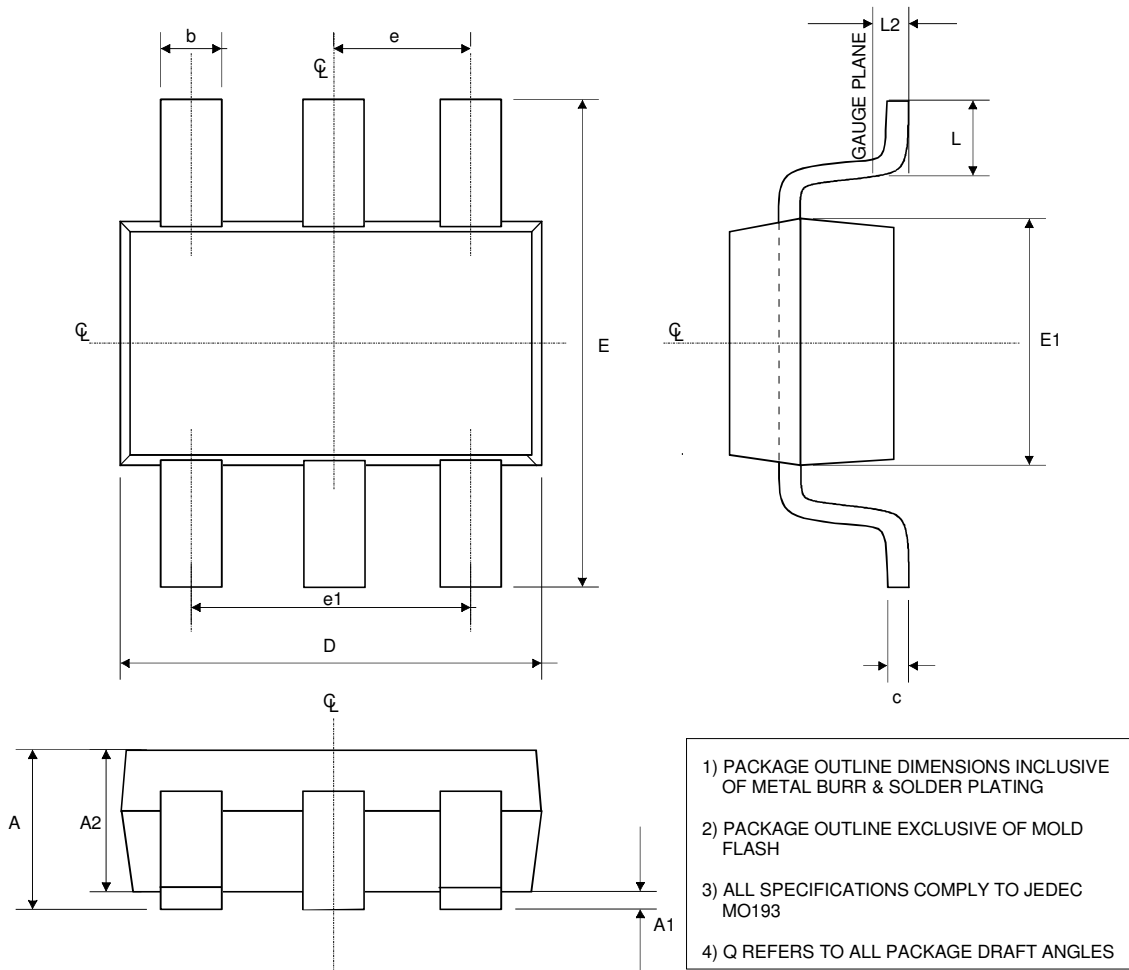

Symbol	Min	Nom	Max	Unit
A	--	--	1.00	mm
A1	0.01	0.05	0.10	mm
A2	0.84	0.87	0.90	mm
b	0.30	--	0.45	mm
c	0.12	0.127	0.20	mm
D		2.90BSC		mm
E		2.80BSC		mm
E1		1.60BSC		mm
e		0.95BSC		mm
e1		1.90BSC		mm
L	0.30	0.40	0.50	mm
L2		0.25BSC		mm
Q	4°	10°	12°	

## SOLDERING INFORMATION (TSOT-6)

◆ For Lead-Free / RoHS Compliant Green TSOT-6

Resistance to Soldering Heat	According to RSH test IEC 68-2-58/20
Maximum Temperature	260°C
Maximum Number of Reflow Cycles	3
Reflow profile	Thermal profile parameters stated in JESD22-A113 should not be exceeded. <a href="http://www.jedec.org">http://www.jedec.org</a>
Seating Plane Co-planarity	max 0.08 mm
Lead Finish	Solder plate 7.62 - 25.4 $\mu\text{m}$ , material Matte Tin

## TAPE & REEL SPECIFICATIONS (TSOT-6)

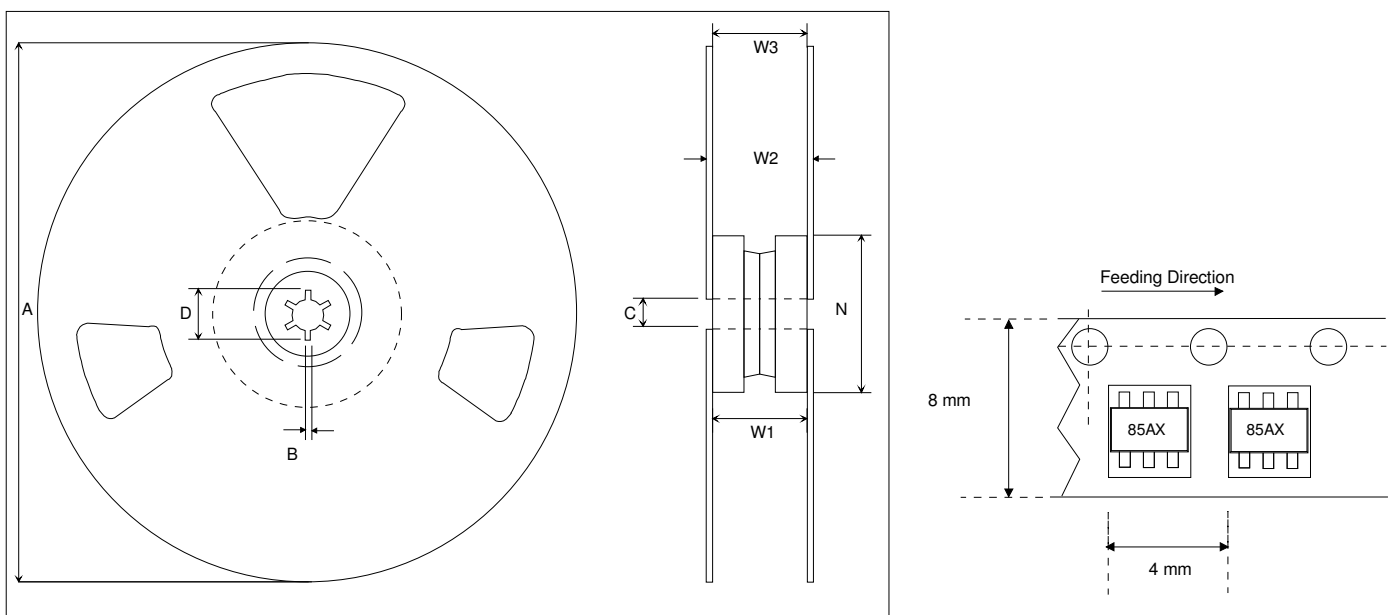

Other Dimensions according to EIA-481 Standard

3000 Components on Each Reel

Dimension	Min	Max	Unit
A		178	mm
B	1.5		mm
C	12.80	13.50	mm
D	20.2		mm
N	50		mm
$W_1$ (measured at hub)	8.4	9.9	mm
$W_2$ (measured at hub)		14.4	mm
$W_3$ (includes flange distortion at outer edge)	7.9	10.9	mm
Trailer	160		mm
Leader	390, of which minimum 160 mm of empty carrier tape sealed with cover tape		mm

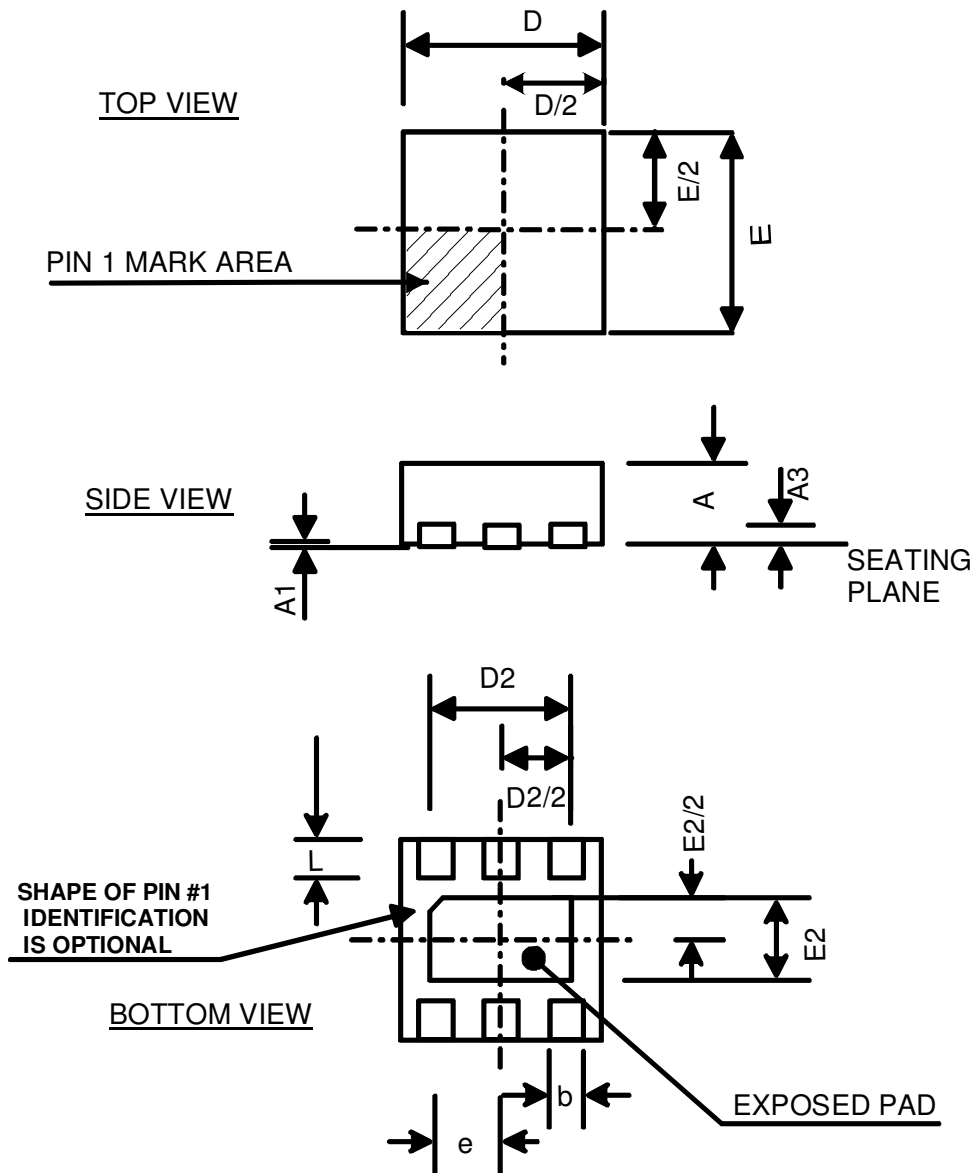
**PACKAGE OUTLINE (QFN-6)**

Symbol	Min	Nom	Max	Unit
PACKAGE DIMENSIONS				
A	0.700	0.750	0.800	mm
A1	0.000	0.020	0.050	mm
A3	0.178	0.203	0.228	mm
b	0.200	0.250	0.300	mm
D	2.000 BSC			mm
D2 (Exposed pad)	1.350	1.400	1.450	mm
E	2.000 BSC			mm
E2 (Exposed pad)	0.750	0.800	0.850	mm
e	0.650 BSC			mm
L	0.300	0.350	0.400	mm

Dimensions do not include mold or interlead flash, protrusions or gate burrs.



## SOLDERING INFORMATION (QFN-6)

◆ For Lead-Free / RoHS Compliant Green QFN 2mm x 2mm x 0.75mm

Resistance to Soldering Heat	According to RSH test IEC 68-2-58/20
Maximum Temperature	260°C
Maximum Number of Reflow Cycles	3
Reflow profile	Thermal profile parameters stated in IPC/JEDEC J-STD-020 should not be exceeded. <a href="http://www.jedec.org">http://www.jedec.org</a>
Lead Finish	7.62 - 25.4 μm, Matte Tin

## EMBOSSED TAPE SPECIFICATIONS (QFN-6)

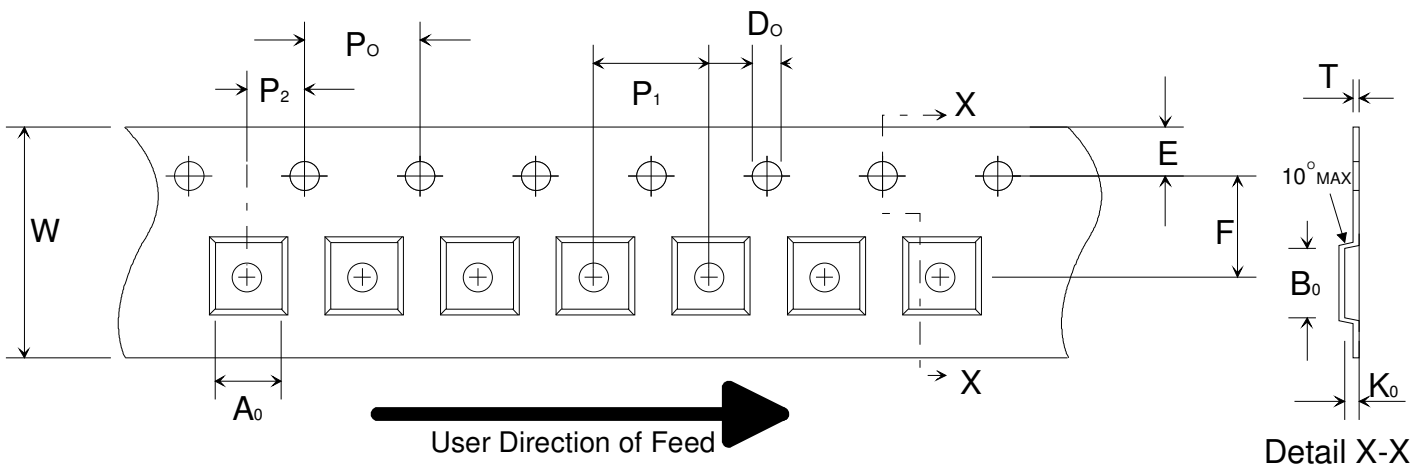

Dimension	Min/Max	Unit
$A_0$	2.30 ±0.05	mm
$B_0$	2.30 ±0.05	mm
$D_0$	1.50 +0.1/-0.0	mm
$E$	1.75 ±0.10	mm
$F$	3.50 ±0.05	mm
$K_0$	1.00 ±0.05	mm
$P_0$	4.0	mm
$P_1$	4.0 ±0.10	mm
$P_2$	2.0 ±0.05	mm
$T$	0.254 ±0.02	mm
$W$	8.00 ±0.3/-0.1	mm

**REEL SPECIFICATIONS (QFN-6)**

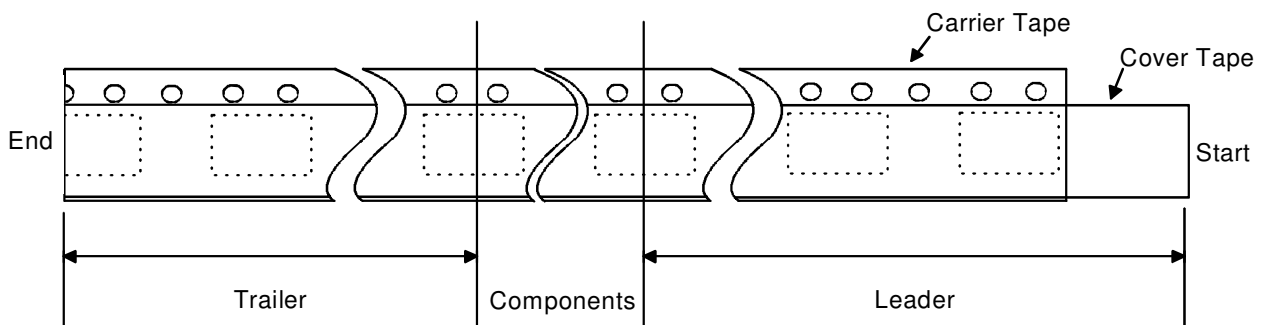
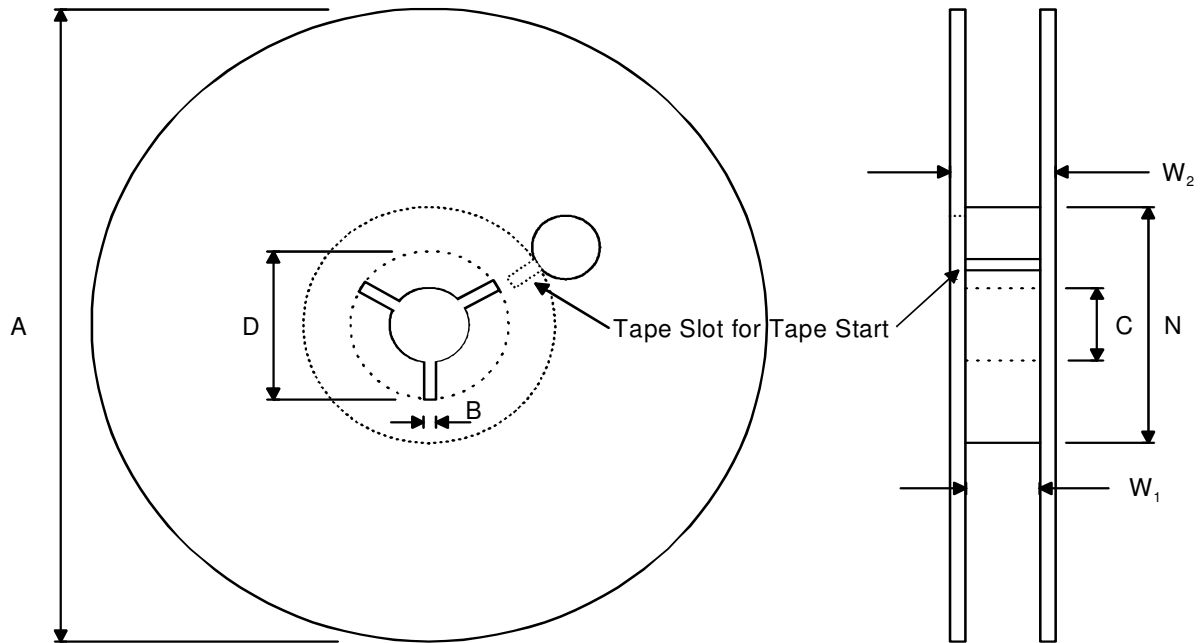

Dimension	Min	Max	Unit
A		178	mm
B	1.5		mm
C	12.80	13.50	mm
D	20.2		mm
N	50		mm
$W_1$ (measured at hub)	8.4	9.90	mm
$W_2$ (measured at hub)		14.4	mm
Trailer	160		mm
Leader	390, of which minimum 160 mm of empty carrier tape sealed with cover tape		mm

3000 Components on Each Reel

Reel Material: Conductive, Plastic Antistatic or Static Dissipative  
Carrier Tape Material: Conductive

---

## ORDERING INFORMATION

---

Product Code	Product	Package	Comments
MAS9285A1TG00	IC FOR XO Trimming	Tested wafers 215 µm	Die size 794 x 940 µm
MAS9285A1GC06	IC FOR XO Trimming	TSOT-6 Pb-free, RoHS compliant	T&R/3000 pcs/reel
MAS9285A1HU06	IC FOR XO Trimming	QFN-6 Pb-free, RoHS compliant	T&R/3000 pcs/reel

Please contact Micro Analog Systems Oy for other wafer thickness options.

---

## LOCAL DISTRIBUTOR

---

---

## MICRO ANALOG SYSTEMS OY CONTACTS

---

Micro Analog Systems Oy Kamreerintie 2, P.O. Box 51 FIN-02771 Espoo, FINLAND	Tel. +358 9 80 521 Fax +358 9 805 3213 <a href="http://www.mas-oy.com">http://www.mas-oy.com</a>
--	--

### NOTICE

Micro Analog Systems Oy reserves the right to make changes to the products contained in this data sheet in order to improve the design or performance and to supply the best possible products. Micro Analog Systems Oy assumes no responsibility for the use of any circuits shown in this data sheet, conveys no license under any patent or other rights unless otherwise specified in this data sheet, and makes no claim that the circuits are free from patent infringement. Applications for any devices shown in this data sheet are for illustration only and Micro Analog Systems Oy makes no claim or warranty that such applications will be suitable for the use specified without further testing or modification.