

# 32-bit Proprietary Microcontroller

CMOS

## FR60Lite MB91260B Series

### MB91263B/MB91F264B

#### ■ DESCRIPTION

The MB91260B series is a 32-bit RISC microcontroller designed by Fujitsu for embedded control applications which require high-speed processing.

The CPU is used the FR family and the compatibility of FR60Lite.

#### ■ FEATURES

- FR60Lite CPU
    - 32-bit RISC, load/store architecture with a five-stage pipeline
    - Maximum operating frequency : 33 MHz (oscillation frequency 4.192 MHz, oscillation frequency 8-multiplier (PLL clock multiplication method))
    - 16-bit fixed length instructions (basic instructions)
    - Execution speed of instructions : 1 instruction per cycle
    - Memory-to-memory transfer, bit handling, barrel shift instructions, etc : Instructions suitable for embedded applications
    - Function entry/exit instructions, multiple-register load/store instructions : Instructions adapted for C-language
- (Continued)*

#### ■ PACKAGES

100-pin plastic QFP

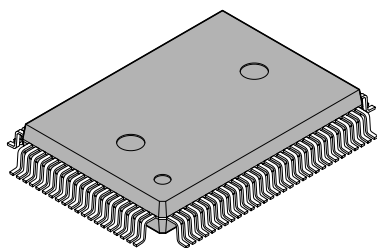

(FTP-100P-M06)

100-pin plastic LQFP

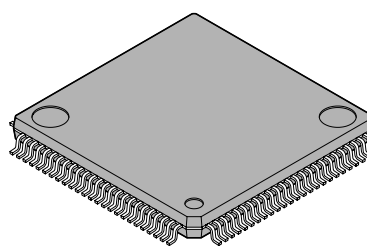

(FTP-100P-M05)

# MB91260B Series

(Continued)

- Register interlock function : Facilitates coding in assembler.
- Built-in multiplier with instruction-level support
  - 32 bit multiplication with sign : 5 cycles
  - 16 bit multiplication with sign : 3 cycles
- Interrupt (PC, PS save) : 6 cycles, 16 priority levels
- Harvard architecture allowing program access and data access to be executed simultaneously
- FR family instruction compatible
- Internal peripheral functions
  - Capacity of internal ROM and ROM type
    - MASK ROM : 128 KB (MB91263B)
    - FLASH ROM : 256 KB (MB91F264B)
  - Capacity of internal RAM : 8 KB
  - A/D converter (sequential comparison type)
  - Resolution : 10 bits : 2 ch × 2 units, 8 ch × 1 unit
  - Conversion time : 1.2 μs (Minimum conversion time system clock at 33 MHz)  
1.35 μs (Minimum conversion time system clock at 20 MHz)
  - External interrupt input : 10 ch
  - Bit search module (for REALOS)  
Function for searching the MSB in each word for the first 1-to-0 inverted bit position
  - UART (Full-duplex double buffer) : 3 ch  
Selectable parity On/Off  
Asynchronous (start-stop synchronized) or clock-synchronous communications selectable  
Internal timer for dedicated baud rate (U-Timer) on each channel  
External clock can be used as transfer clock  
Error detection function for parity, frame and overrun errors
  - 8/16-bit PPG timer : 16 ch (at 8-bit) / 8 ch (at 16-bit)
  - Reload timer : 3 ch (with cascade mode, without output of reload timer 0)
  - Free-run timer : 1 ch
  - PWC timer : 2 ch
  - Input capture : 4 ch (interface with free-run timer)
  - Output compare : 6 ch (interface with free-run timer)
  - Waveform generator  
Various waveforms which are generated by using output compare, 16-bit PPG timer 0 and 16-bit dead timer
  - SUM of products macro (simple DSP)
    - RAM : instruction RAM    256 × 16-bit
    - XRAM                      64 × 16-bit
    - YRAM                      64 × 16-bitExecution of 1 cycle product addition (16-bit × 16-bit + 40 bits)  
Operation results are extracted rounded from 40 to 16 bits
  - DMAC (DMA Controller) : 5 ch  
Operation of transfer and activation by internal peripheral interrupts and software
  - Watchdog timer
  - Low Power Consumption Mode  
Sleep/stop function
  - Package : QFP-100, LQFP-100
  - Technology : CMOS 0.35 μm
  - Power supply : 1-power supply [V<sub>cc</sub> = 4.0 V to 5.5 V]

## ■ PIN ASSIGNMENT

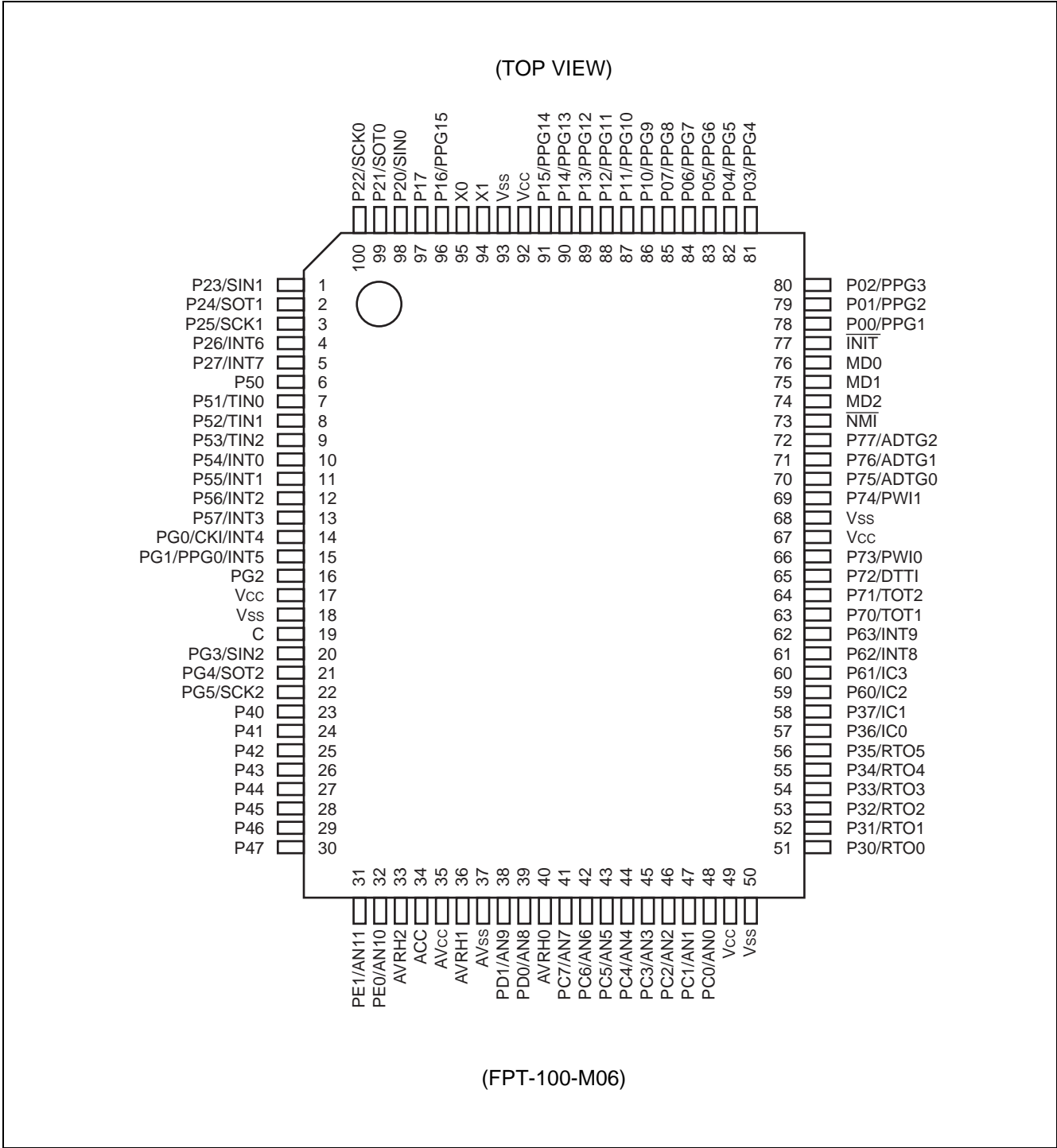

(Continued)

# MB91260B Series

(Continued)

(TOP VIEW)

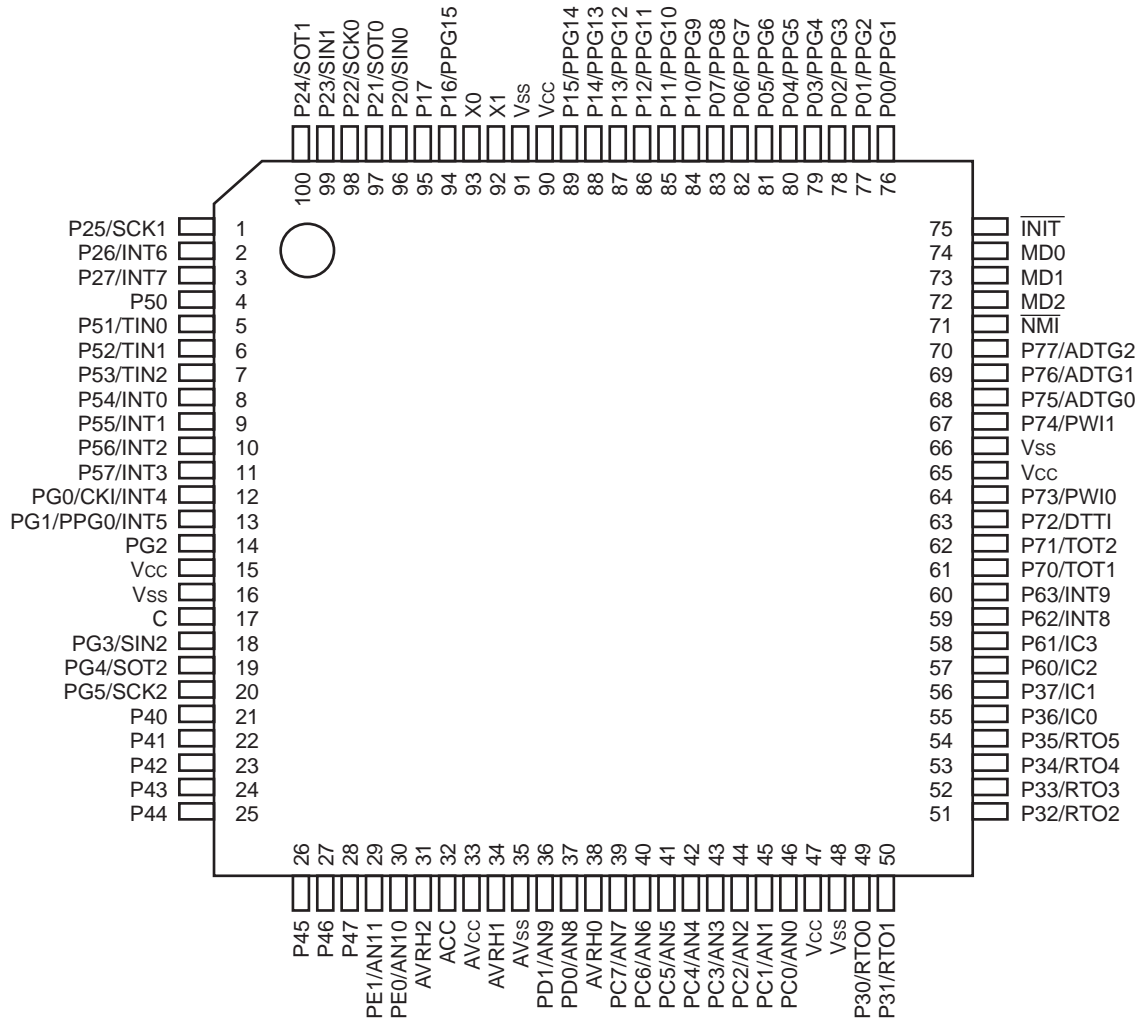

(FPT-100-M05)

## ■ PIN DESCRIPTION

Pin no.		Pin name	Circuit type	Description
QFP	LQFP			
1	99	SIN1	D	UART1 data input terminal. When use the terminal as data input of UART1, set the corresponding data direction resister (DDR) to input.
		P23		General purpose input/output port. This function is always valid.
2	100	SOT1	D	UART1 data output terminal. This function becomes valid when data output of UART1 is set to enabled.
		P24		General purpose input/output port. This function becomes valid when data output of UART1 is set to disabled.
3	1	SCK1	D	UART1 clock input/output terminal. This function becomes valid when clock input/output is set to enabled.
		P25		General purpose input/output port. This function becomes valid when clock input/output is set to disabled.
4	2	INT6	E	External interrupt input terminal. When use the terminal as external interrupt input, set the corresponding data direction resister (DDR) to input.
		P26		General purpose input/output port. This function is always valid.
5	3	INT7	E	External interrupt input terminal. When use the terminal as external interrupt input, set the corresponding data direction resister (DDR) to input.
		P27		General purpose input/output port. This function is always valid.
6	4	P50	C	General purpose input/output port.
7	5	TIN0	C	External trigger input terminal of reload timer 0. When use the terminal as trigger input, set the corresponding data direction resister (DDR) to input.
		P51		General purpose input/output port. This function is always valid.
8	6	TIN1	C	External trigger input terminal of reload timer 1. When use the terminal as external trigger input, set the corresponding data direction resister (DDR) to input.
		P52		General purpose input/output port. This function is always valid.

(Continued)

# MB91260B Series

Pin no.		Pin name	Circuit type	Description
QFP	LQFP			
9	7	TIN2	C	External trigger input terminal of reload timer 2. When use the terminal as external trigger input, set the corresponding data direction resistor (DDR) to input.
		P53		General purpose input/output port. This function is always valid.
10	8	INT0	E	External interrupt input terminal. When use the terminal as external interrupt input, set the corresponding data direction resistor (DDR) to input.
		P54		General purpose input/output port. This function is always valid.
11	9	INT1	E	External interrupt input terminal. When use the terminal as external interrupt input, set the corresponding data direction resistor (DDR) to input.
		P55		General purpose input/output port. This function is always valid.
12	10	INT2	E	External interrupt input terminal. When use the terminal as external interrupt input, set the corresponding data direction resistor (DDR) to input.
		P56		General purpose input/output port. This function is always valid.
13	11	INT3	E	External interrupt input terminal. When use the terminal as external interrupt input, set the corresponding data direction resistor (DDR) to input.
		P57		General purpose input/output port. This function is always valid.
14	12	CKI	E	External clock input terminal for free-run timer. When use the terminal as external clock input of free-run timer, set the corresponding data direction resistor (DDR) to input.
		INT4		External interrupt input terminal. When use the terminal as external interrupt input, set the corresponding data direction resistor (DDR) to input.
		PG0		General purpose input/output port. This function is always valid.

(Continued)

# MB91260B Series

Pin no.		Pin name	Circuit type	Description
QFP	LQFP			
15	13	PPG0	E	Output terminal of PPG timer 0. This function becomes valid when output of PPG timer 0 is set to enabled.
		INT5		External interrupt input terminal. When use the terminal as external input, output of PPG timer 0 is set to disabled, and set the corresponding data direction resistor (DDR) to input.
		PG1		General purpose input/output port. This function becomes valid when output of PPG timer 0 is set to disabled.
16	14	PG2	C	General purpose input/output port.
20	18	SIN2	D	UART2 data input terminal. When use the terminal as data input of UART2, set the corresponding data direction resistor (DDR) to input.
		PG3		General purpose input/output port. This function is always valid.
21	19	SOT2	D	UART2 data output terminal. This function becomes valid when data output of UART2 is set to enabled.
		PG4		General purpose input/output port. This function becomes valid when data output of UART2 is set to disabled.
22	20	SCK2	D	UART2 clock input/output terminal. This function becomes valid when clock input/output of UART2 is set to enabled.
		PG5		General purpose input/output port. This function becomes valid when clock input/output of UART2 is set to disabled.
23	21	P40	C	General purpose input/output port.
24	22	P41	C	General purpose input/output port.
25	23	P42	C	General purpose input/output port.
26	24	P43	C	General purpose input/output port.
27	25	P44	C	General purpose input/output port.
28	26	P45	C	General purpose input/output port.
29	27	P46	C	General purpose input/output port.
30	28	P47	C	General purpose input/output port.
31	29	AN11	G	Analog input terminal of A/D converter. This function becomes valid when set the corresponding AICR2 register to analog input.
		PE1		General purpose input/output port. This function becomes valid when set the corresponding AICR2 register to port.

(Continued)

# MB91260B Series

Pin no.		Pin name	Circuit type	Description
QFP	LQFP			
32	30	AN10	G	Analog input terminal of A/D converter. This function becomes valid when set the corresponding AICR2 register to analog input.
		PE0		General purpose input/output port. This function becomes valid when set the corresponding AICR2 register to port.
38	36	AN9	G	Analog input terminal of A/D converter. This function becomes valid when set the corresponding AICR1 register to analog input.
		PD1		General purpose input/output port. This function becomes valid when set the corresponding AICR1 register to port.
39	37	AN8	G	Analog input terminal of A/D converter. This function becomes valid when set the corresponding AICR1 register to analog input.
		PD0		General purpose input/output port. This function becomes valid when set the corresponding AICR1 register to port.
41	39	AN7	G	Analog input terminal of A/D converter. This function becomes valid when set the corresponding AICR0 register to analog input.
		PC7		General purpose input/output port. This function becomes valid when set the corresponding AICR0 register to port.
42	40	AN6	G	Analog input terminal of A/D converter. This function becomes valid when set the corresponding AICR0 register to analog input.
		PC6		General purpose input/output port. This function becomes valid when set the corresponding AICR0 register to port.
43	41	AN5	G	Analog input terminal of A/D converter. This function becomes valid when set the corresponding AICR0 register to analog input.
		PC5		General purpose input/output port. This function becomes valid when set the corresponding AICR0 register to port.
44	42	AN4	G	Analog input terminal of A/D converter. This function becomes valid when set the corresponding AICR0 register to analog input.
		PC4		General purpose input/output port. This function becomes valid when set the corresponding AICR0 register to port.
45	43	AN3	G	Analog input terminal of A/D converter. This function becomes valid when set the corresponding AICR0 register to analog input.
		PC3		General purpose input/output port. This function becomes valid when set the corresponding AICR0 register to port.

(Continued)



# MB91260B Series

Pin no.		Pin name	Circuit type	Description
QFP	LQFP			
46	44	AN2	G	Analog input terminal of A/D converter. This function becomes valid when set the corresponding AICR0 register to analog input.
		PC2		General purpose input/output port. This function becomes valid when set the corresponding AICR0 register to port.
47	45	AN1	G	Analog input terminal of A/D converter. This function becomes valid when set the corresponding AICR0 register to analog input.
		PC1		General purpose input/output port. This function becomes valid when set the corresponding AICR0 register to port.
48	46	AN0	G	Analog input terminal of A/D converter. This function becomes valid when set the corresponding AICR0 register to analog input.
		PC0		General purpose input/output port. This function becomes valid when set the corresponding AICR0 register to port.
51	49	RTO0	J	Waveform generator output terminal of multi-function timer. This terminal outputs waveform set at the waveform generator. This function becomes valid when waveform generator output of multi-function timer is set to enabled.
		P30		General purpose input/output port. This function becomes valid when output of waveform generator is set to disabled.
52	50	RTO1	J	Waveform generator output terminal of multi-function timer. This terminal outputs waveform set at the waveform generator. This function becomes valid when waveform generator output of multi-function timer is set to enabled.
		P31		General purpose input/output port. This function becomes valid when output of waveform generator is set to disabled.
53	51	RTO2	J	Waveform generator output terminal of multi-function timer. This terminal outputs waveform set at the waveform generator. This function becomes valid when waveform generator output of multi-function timer is set to enabled.
		P32		General purpose input/output port. This function becomes valid when output of waveform generator is set to disabled.
54	52	RTO3	J	Waveform generator output terminal of multi-function timer. This terminal outputs waveform set at the waveform generator. This function becomes valid when waveform generator output of multi-function timer is set to enabled.
		P33		General purpose input/output port. This function becomes valid when output of waveform generator is set to disabled.

(Continued)

# MB91260B Series

Pin no.		Pin name	Circuit type	Description
QFP	LQFP			
55	53	RTO4	J	Waveform generator output terminal of multi-function timer. This terminal outputs waveform set at the waveform generator. This function becomes valid when waveform generator output of multi-function timer is set to enabled.
		P34		General purpose input/output port. This function becomes valid when output of waveform generator is set to disabled.
56	54	RTO5	J	Waveform generator output terminal of multi-function timer. This terminal outputs waveform set at the waveform generator. This function becomes valid when waveform generator output of multi-function timer is set to enabled.
		P35		General purpose input/output port. This function becomes valid when output of waveform generator is set to disabled.
57	55	IC0	D	Trigger input terminal of input capture 0. When use the terminal as trigger input of input capture, set the corresponding data direction resistor (DDR) to input.
		P36		General purpose input/output port. This function is always valid.
58	56	IC1	D	Trigger input terminal of input capture 1. When use the terminal as trigger input of input capture, set the corresponding data direction resistor (DDR) to input.
		P37		General purpose input/output port. This function is always valid.
59	57	IC2	D	Trigger input terminal of input capture 2. When use the terminal as trigger input of input capture, set the corresponding data direction resistor (DDR) to input.
		P60		General purpose input/output port. This function is always valid.
60	58	IC3	D	Trigger input terminal of input capture 3. When use the terminal as trigger input of input capture, set the corresponding data direction resistor (DDR) to input.
		P61		General purpose input/output port. This function is always valid.
61	59	INT8	E	External interrupt input terminal. When use the terminal as external input, set the corresponding data direction resistor (DDR) to input.
		P62		General purpose input/output port. This function is always valid.
62	60	INT9	E	External interrupt input terminal. When use the terminal as external input, set the corresponding data direction resistor (DDR) to input.
		P63		General purpose input/output port. This function is always valid.

(Continued)

# MB91260B Series

Pin no.		Pin name	Circuit type	Description
QFP	LQFP			
63	61	TOT1	C	Output terminal of reload timer 1. This function becomes valid when reload timer output is set to enabled.
		P70		General purpose input/output port. This function becomes valid when reload timer output is set to disabled.
64	62	TOT2	C	Output terminal of reload timer 2. This function becomes valid when reload timer output is set to enabled.
		P71		General purpose input/output port. This function becomes valid when reload timer output is set to disabled.
65	63	DTTI	D	Output control input terminal of waveform generator output terminal RTO0 to RTO5 of multi-function timer. This function becomes valid when DTTI input is set to enabled by waveform generator of multi-function timer.
		P72		General purpose input/output port. This function is always valid.
66	64	PW10	D	Pulse width counter input terminal of PWC timer 0. This function becomes valid when pulse width counter input of PWC timer 0 is set to enabled.
		P73		General purpose input/output port. This function is always valid.
69	67	PW11	D	Pulse width counter input terminal of PWC timer 1. This function becomes valid when pulse width counter input of PWC timer 1 is set to enabled.
		P74		General purpose input/output port. This function is always valid.
70	68	ADTG0	C	External trigger input terminal of A/D converter 0. When use the external trigger as activation factor of A/D convertor, set the corresponding data direction resistor (DDR) to input.
		P75		General purpose input/output port. This function is always valid.
71	69	ADTG1	C	External trigger input terminal of A/D converter 1. When use the external trigger as activation factor of A/D convertor, set the corresponding data direction resistor (DDR) to input.
		P76		General purpose input/output port. This function is always valid.
72	70	ADTG2	C	External trigger input terminal of A/D converter 2. When use the external trigger as activation factor of A/D convertor, set the corresponding data direction resistor (DDR) to input.
		P77		General purpose input/output port. This function is always valid.
73	71	$\overline{\text{NMI}}$	H	NMI (Non Maskable Interrupt) input terminal.

(Continued)

# MB91260B Series

Pin no.		Pin name	Circuit type	Description
QFP	LQFP			
74	72	MD2	K	Mode terminal 2. Set operating mode. Connect to V <sub>CC</sub> or V <sub>SS</sub> .
75	73	MD1	K	Mode terminal 1. Set operating mode. Connect to V <sub>CC</sub> or V <sub>SS</sub> .
76	74	MD0	K	Mode terminal 0. Set operating mode. Connect to V <sub>CC</sub> or V <sub>SS</sub> .
77	75	INIT	I	External reset input terminal.
78	76	PPG1	C	Output terminal of PPG timer 1. This function becomes valid when output of PPG timer 1 is set to enabled.
		P00		General purpose input/output port. This function becomes valid when output of PPG timer 1 is set to disabled.
79	77	PPG2	C	Output terminal of PPG timer 2. This function becomes valid when output of PPG timer 2 is set to enabled.
		P01		General purpose input/output port. This function becomes valid when output of PPG timer 2 is set to disabled.
80	78	PPG3	C	Output terminal of PPG timer 3. This function becomes valid when output of PPG timer 3 is set to enabled.
		P02		General purpose input/output port. This function becomes valid when output of PPG timer 3 is set to disabled.
81	79	PPG4	C	Output terminal of PPG timer 4. This function becomes valid when output of PPG timer 4 is set to enabled.
		P03		General purpose input/output port. This function becomes valid when output of PPG timer 4 is set to disabled.
82	80	PPG5	C	Output terminal of PPG timer 5. This function becomes valid when output of PPG timer 5 is set to enabled.
		P04		General purpose input/output port. This function becomes valid when output of PPG timer 5 is set to disabled.
83	81	PPG6	C	Output terminal of PPG timer 6. This function becomes valid when output of PPG timer 6 is set to enabled.
		P05		General purpose input/output port. This function becomes valid when output of PPG timer 6 is set to disabled.
84	82	PPG7	C	Output terminal of PPG timer 7. This function becomes valid when output of PPG timer 7 is set to enabled.
		P06		General purpose input/output port. This function becomes valid when output of PPG timer 7 is set to disabled.

(Continued)

# MB91260B Series

Pin no.		Pin name	Circuit type	Description
QFP	LQFP			
85	83	PPG8	C	Output terminal of PPG timer 8. This function becomes valid when output of PPG timer 8 is set to enabled.
		P07		General purpose input/output port. This function becomes valid when output of PPG timer 8 is set to disabled.
86	84	PPG9	C	Output terminal of PPG timer 9. This function becomes valid when output of PPG timer 9 is set to enabled.
		P10		General purpose input/output port. This function becomes valid when output of PPG timer 9 is set to disabled.
87	85	PPG10	C	Output terminal of PPG timer 10. This function becomes valid when output of PPG timer 10 is set to enabled.
		P11		General purpose input/output port. This function becomes valid when output of PPG timer 10 is set to disabled.
88	86	PPG11	C	Output terminal of PPG timer 11. This function becomes valid when output of PPG timer 11 is set to enabled.
		P12		General purpose input/output port. This function becomes valid when output of PPG timer 11 is set to disabled.
89	87	PPG12	C	Output terminal of PPG timer 12. This function becomes valid when output of PPG timer 12 is set to enabled.
		P13		General purpose input/output port. This function becomes valid when output of PPG timer 12 is set to disabled.
90	88	PPG13	C	Output terminal of PPG timer 13. This function becomes valid when output of PPG timer 13 is set to enabled.
		P14		General purpose input/output port. This function becomes valid when output of PPG timer 13 is set to disabled.
91	89	PPG14	C	Output terminal of PPG timer 14. This function becomes valid when output of PPG timer 14 is set to enabled.
		P15		General purpose input/output port. This function becomes valid when output of PPG timer 14 is set to disabled.
94	92	X1	A	Main clock oscillation output terminal.
95	93	X0	A	Main clock oscillation input terminal.
96	94	PPG15	C	Output terminal of PPG timer 15. This function becomes valid when output of PPG timer 15 is set to enabled.
		P16		General purpose input/output port. This function becomes valid when output of PPG timer 15 is set to disabled.
97	95	P17	C	General purpose input/output port.
98	96	SIN0	D	UART0 data input terminal. When use the terminal as data input of UART0, set the corresponding data direction resistor (DDR) to input.
		P20		General purpose input/output port. This function is always valid.

(Continued)

# MB91260B Series

(Continued)

Pin no.		Pin name	Circuit type	Description
QFP	LQFP			
99	97	SOT0	D	UART0 data output terminal. This function becomes valid when data output of UART0 is set to enabled.
		P21		General purpose input/output port. This function becomes valid when data output of UART0 is set to disabled.
100	98	SCK0	D	UART0 clock input/output terminal. This function becomes valid when clock input/output of UART0 is set to enabled.
		P22		General purpose input/output port. This function becomes valid when clock input/output of UART0 is set to disabled.

## • Power supply and GND pins

Pin no.		Pin name	Description
QFP	LQFP		
18, 50, 68, 93	16, 48, 66, 91	Vss	GND pins. Apply equal potential to all of the pins.
17, 49, 67, 92	15, 47, 65, 90	Vcc	Power supply pin. Apply equal potential to all of the pins.
35	33	AVcc	Analog power supply pin for A/D converter.
33	31	AVRH2	Analog reference power supply pin for A/D converter 2.
36	34	AVRH1	Analog reference power supply pin for A/D converter 1.
40	38	AVRH0	Analog reference power supply pin for A/D converter 0.
37	35	AVss	Analog GND pin for A/D converter.
19	17	C	Condenser connection pin for internal regulator.
34	32	ACC	Condenser connection pin for analog.

## I/O CIRCUIT TYPE

Type	Circuit type	Remarks
A		<ul style="list-style-type: none"> <li>• Oscillation circuit</li> <li>• Oscillation feedback resistance : approx. 1 MΩ</li> </ul>
C		<ul style="list-style-type: none"> <li>• CMOS level output</li> <li>• CMOS level input.</li> <li>• With standby control</li> <li>• With Pull-up control</li> <li>• Pull-up resistance value = approx. 50 kΩ (Typ)</li> <li>• <math>I_{OL} = 4 \text{ mA}</math></li> </ul>
D		<ul style="list-style-type: none"> <li>• CMOS level output</li> <li>• CMOS level hysteresis input.</li> <li>• With standby control</li> <li>• With Pull-up control</li> <li>• Pull-up resistance value = approx. 50 kΩ (Typ)</li> <li>• <math>I_{OL} = 4 \text{ mA}</math></li> </ul>

(Continued)

# MB91260B Series

Type	Circuit type	Remarks
E		<ul style="list-style-type: none"> <li>• CMOS level output</li> <li>• CMOS level hysteresis input.</li> <li>• Without standby control</li> <li>• With Pull-up control</li> <li>• Pull-up resistance value = approx. 50 kΩ (Typ)</li> <li>• <math>I_{OL} = 4 \text{ mA}</math></li> </ul>
G		<ul style="list-style-type: none"> <li>• Analog/CMOS level input/output pin</li> <li>• CMOS level output</li> <li>• CMOS level input. (attached with standby control)</li> <li>• Analog input (Analog input is enabled when AICR's corresponding bit is set to "1".)</li> <li>• <math>I_{OL} = 4 \text{ mA}</math></li> </ul>
H		<ul style="list-style-type: none"> <li>• CMOS level hysteresis input.</li> <li>• Without standby control</li> </ul>

(Continued)



(Continued)

Type	Circuit type	Remarks
I		<ul style="list-style-type: none"> <li>• CMOS level hysteresis input.</li> <li>• With pull-up resistor</li> <li>• Pull-up resistance value = approx. 50 kΩ (Typ)</li> <li>• Without standby control</li> </ul>
J		<ul style="list-style-type: none"> <li>• CMOS level output</li> <li>• CMOS level hysteresis input.</li> <li>• With standby control</li> <li>• <math>I_{OL} = 12 \text{ mA}</math></li> </ul>
K		<ul style="list-style-type: none"> <li>• CMOS level input.</li> <li>• Without standby control</li> </ul>

# MB91260B Series

## ■ HANDLING DEVICES

- Preventing Latchup

Latch-up may occur in a CMOS IC if a voltage greater than  $V_{CC}$  or less than  $V_{SS}$  is applied to an input or output pin or if an above-rating voltage is applied between  $V_{CC}$  and  $V_{SS}$ .

A latchup, if it occurs, significantly increases the power supply current and may cause thermal destruction of an element. When you use a CMOS IC, be very careful not to exceed the maximum rating.

- Treatment of Unused Input Pins

Do not leave an unused input pin open, since it may cause a malfunction. Handle by, for example, using a pull-up or pull-down resistor.

- About power supply pins

In products with multiple  $V_{CC}$  or  $V_{SS}$  pins, the pins of the same potential are internally connected in the device to avoid abnormal operations including latch-up. However you must connect the pins to external a same potential power supply and a ground line to lower the electro-magnetic emission level to prevent abnormal operation of strobe signals caused by the rise in the ground level, and to conform to the total current rating.

The power pins should be connected to  $V_{CC}$  and  $V_{SS}$  of this device at the lowest possible impedance from the current supply source.

It is also advisable to connect a ceramic bypass capacitor of approximately 0.1  $\mu\text{F}$  between  $V_{CC}$  and  $V_{SS}$  near this device.

- About Crystal oscillator circuit

Noise near the X0 and X1 pin may cause the device to malfunction.

Design the circuit board so that X0 and X1, the crystal oscillator (or ceramic oscillator), and the bypass capacitor to ground are located as close to the device as possible.

It is strongly recommended to design the PC board artwork with the X0 and X1 pins surrounded by ground plane because stable operation can be expected with such a layout.

- Mode pins (MD0 to MD2)

These pins should be connected directly to  $V_{CC}$  or  $V_{SS}$ .

To prevent the device erroneously switching to test mode due to noise, design the printed circuit board such that the distance between the mode pins and  $V_{CC}$  or  $V_{SS}$  is as short as possible and the connection impedance is low.

- Operation at start-up

Be sure to execute setting initialized reset (INIT) with  $\overline{\text{INIT}}$  pin immediately after start-up.

Also, in order to provide a delay while the oscillator circuit stabilize immediately after start-up, maintain the "L" level input to the  $\overline{\text{INIT}}$  pin for the required stabilization wait time.

(For INIT via the  $\overline{\text{INIT}}$  pin, the oscillation stabilization wait time setting is initialized to the minimum value.)

- About oscillation input at power on

When turning the power on, maintain clock input until the device is released from the oscillation stabilization wait state.

- Caution operation during PLL clock mode

Even if the oscillator comes off or the clock input stops with the PLL clock selected for this device, the device may continue to operate at the free-run frequency of the PLL's internal self-oscillating oscillator circuit.

Performance of this operation, however, cannot be guaranteed.

- External clock

When external clock is selected, the opposite phase clock to X0 pin must be supplied to X1 pin simultaneously.

If the STOP mode (oscillation stop mode) is used simultaneously, the X1 pin is stopped with the "H" output. So, when STOP mode is specified, approximately 1 k $\Omega$  of resistance should be added externally to avoid the conflict of output.

The following figure shows using an external clock.

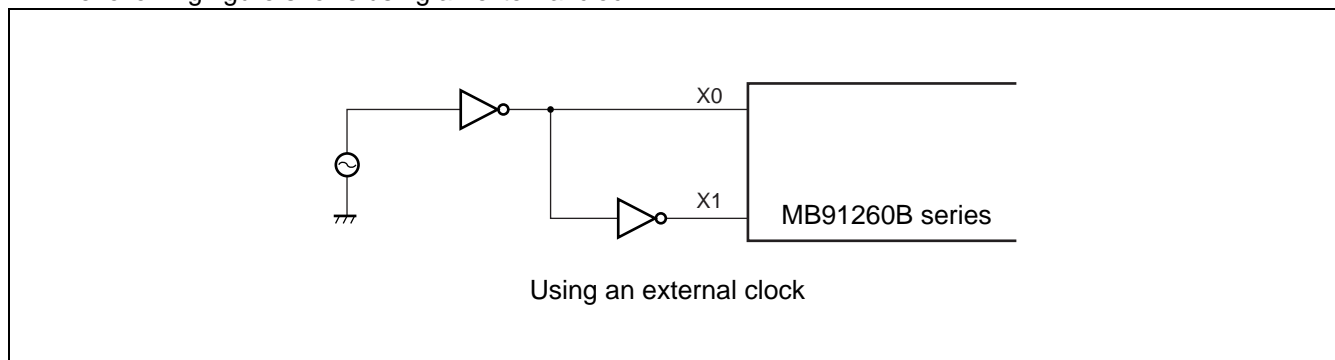

- C pin

A bypass capacitor of approximately 0.1  $\mu$ F should be connected the C pin for built-in regulator.

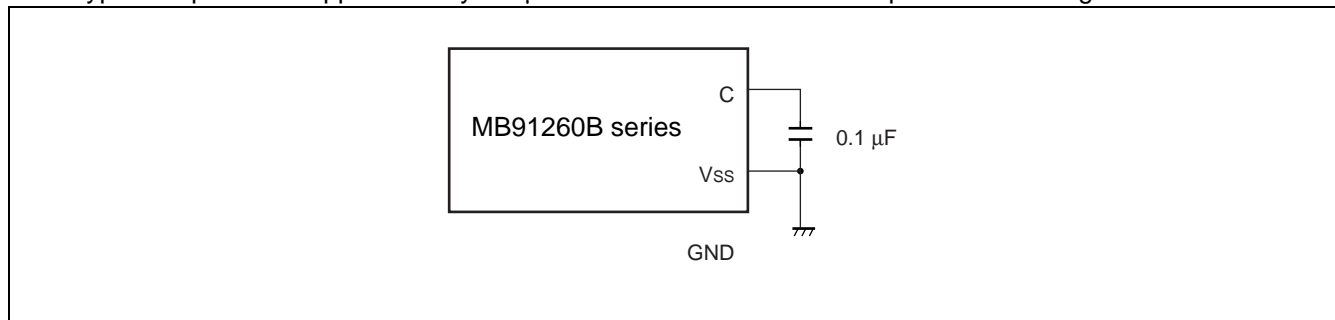

- ACC pin

A capacitor of approximately 0.1  $\mu$ F should be inserted between the ACC pin and the AVcc pin as this product has built-in A/D convertor.

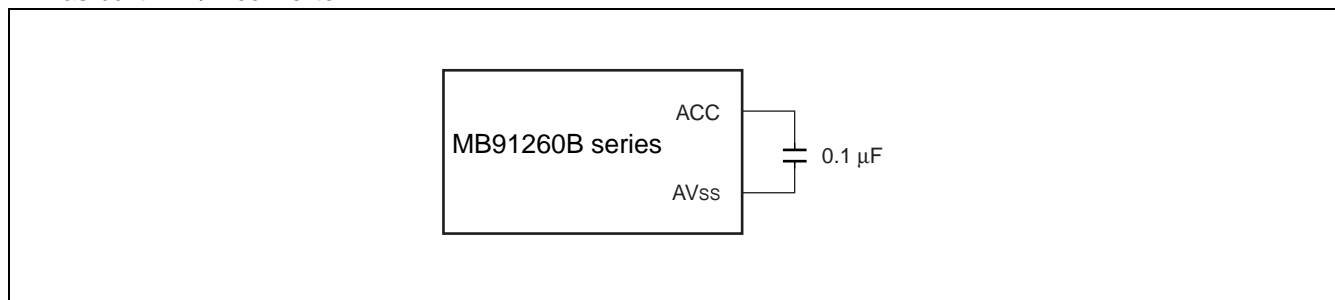

# MB91260B Series

- Clock control block

Take the oscillation stabilization wait time during Low level input to the  $\overline{\text{INIT}}$  pin.

- Switch shared port function

To switch between the use as a port and the use as a dedicated pin, use the port function register (PFR).

- Low Power Consumption Mode

(1) To enter the standby mode, use the synchronous standby mode (set with the SYNCS bit as bit 8 in the TBCR: or time-base counter control register) and be sure to use the following sequence

(LDI	#value_of_standby, R0)	: Value_of_standby is write data to STCR.
(LDI	#_STCR, R12)	: _STCR is address (481H) of STCR.
STB	R0, @R12	: Writing to standby control register (STCR)
LDUB	@R12, R0	: STCR read for synchronous standby
LDUB	@R12, R0	: Dummy re-read of STCR
NOP		: NOP × 5 for arrangement of timing
NOP		
NOP		
NOP		
NOP		

In addition, please set I flag, ILM, and ICR to diverge to the interruption handler that is the return factor after the standby returns.

(2) Please do not do the following when the monitor debugger is used.

- Break point setting for above instruction lines
- Step execution for above instruction lines

- Notes on the PS register

As the PS register is processed by some instructions in advance, exception handling below may cause the interrupt handling routine to break when the debugger is used or the display contents of flags in the PS register to be updated.

As the microcontroller is designed to carry out reprocessing correctly upon returning from such an EIT event, it performs operations before and after the EIT as specified in either case.

1. The following operations are performed when the instruction followed by a DIV0U/DIV0S instruction results in: (a) acceptance of a user interrupt or NMI, (b) step execution, or (c) a break at a data event or emulator menu.

- (1) The D0 and D1 flags are updated in advance.
- (2) An EIT handling routine (user interrupt, NMI, or emulator) is executed.
- (3) Upon returning from the EIT, the DIV0U/DIV0S instruction is executed and the D0 and D1 flags are updated to the same values as in (1).

2. The following operations are performed when the ORCCR/STILM/MOVRi and PS instructions are executed to enable interruptions when a user interrupt or NMI trigger even has occurred.

- (1) The PS register is updated in advance.
- (2) An EIT handling routine (user interrupt, NMI) is executed.
- (3) Upon returning from the EIT, the above instructions are executed and the PS register is updated to the same value as in (1).

- Watch dog timer

The watchdog timer built in this model monitors a program that it defers a reset within a certain period of time. The watchdog timer resets the CPU if the program runs out of controls, preventing the reset defer function from being executed. Once the function of the watchdog timer is enabled, therefore, the watchdog timer keeps on operating programs until it resets the CPU.

As an exception, the watchdog timer defers a reset timing automatically under the condition in which the CPU stops program execution.

# MB91260B Series

## ■ NOTE ON DEBUGGER

- Step execution of RETI command

If an interrupt occurs frequently during step execution, the corresponding interrupt handling routine is executed repeatedly after step execution.

This will prevent the main routine and low-interrupt-level programs from being executed.

Do not execute step of RETI instruction for escape.

Disable the corresponding interrupt and execute debugger when the corresponding interrupt handling routine no longer needs debugging.

- Operand break

Do not apply a data event break to access to the area containing the address of a system stack pointer.

- Execution in an unused area of FLASH memory

Accidentally executing an instruction in an unused area of FLASH memory (with data placed at 0XFFFF) prevents breaks from being accepted.

To prevent this, the code event address mask function of the debugger should be used to cause a break when accessing an instruction in an unused area.

- Power-on debugging

All of the following three conditions must be satisfied when the power supply is turned off by power-on debugging.

(1) The time for the user power to fall from 0.9 VCC to 0.5 VCC is 25  $\mu$ s or longer.

Note : In a dual-power system, VCC indicates the external I/O power supply voltage.

(2) CPU operating frequency must be higher than 1 MHz.

(3) During execution of user program

- Interrupt handler for NMI request (tool)

Add the following program to the interrupt handler to prevent the device from malfunctioning in case the factor flag to be set only in response to a break request from the ICE is set, for example, by an adverse effect of noise to the DSU pin while the ICE is not connected. Enable to use the ICE while adding this program.

Additional location

Next interrupt handler

Interrupt source	:	NMI request (tool)
Interrupt number	:	#13 (decimal) , 0D <sub>H</sub> (hexa decimal)
Offset	:	3C8 <sub>H</sub>
Address TBR is default	:	000FFFC8 <sub>H</sub>

Additional program

```
STM    (R0, R1)
LDI    #B00H, R0;    : B00H is the address of DSU break factor register.
LDI    #0, R1
STB    R1, @R0      : Clear the break factor register.
LDM    (R0, R1)
RETI
```

## ■ BLOCK DIAGRAM

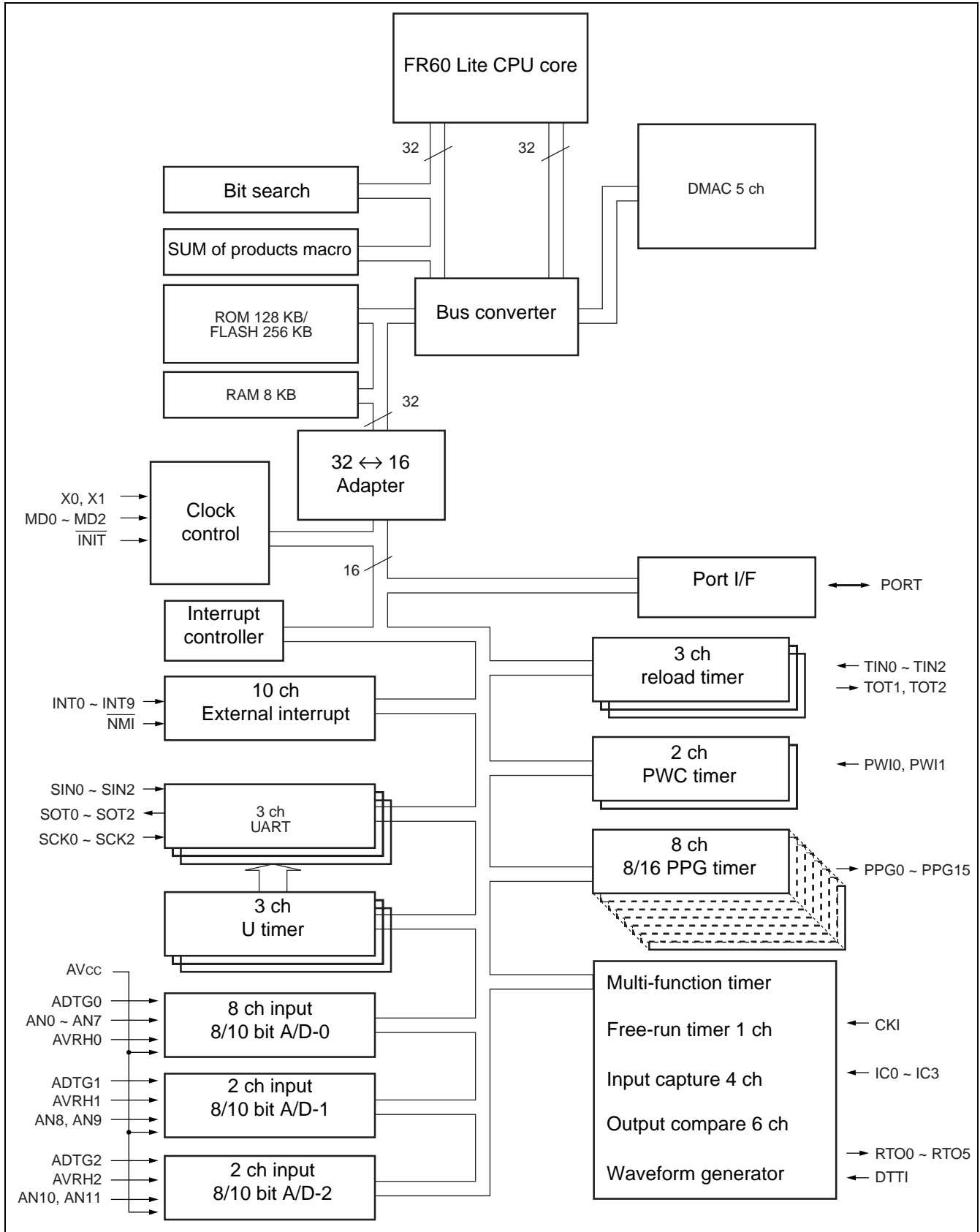

# MB91260B Series

## MEMORY SPACE

### 1. Memory space

The FR family has 4 Gbytes of logical address space ( $2^{32}$  addresses) available to the CPU by linear access.

- Direct Addressing Areas

The following address space areas are used as I/O areas.

These areas are called direct addressing areas, in which the address of an operand can be specified directly during an instruction.

The size of directly addressable areas depends on the data size to be being accessed as follows.

- byte data access : 000-0FF<sub>H</sub>
- half word data access : 000-1FF<sub>H</sub>
- word data access : 000-3FF<sub>H</sub>

### 2. Memory Map

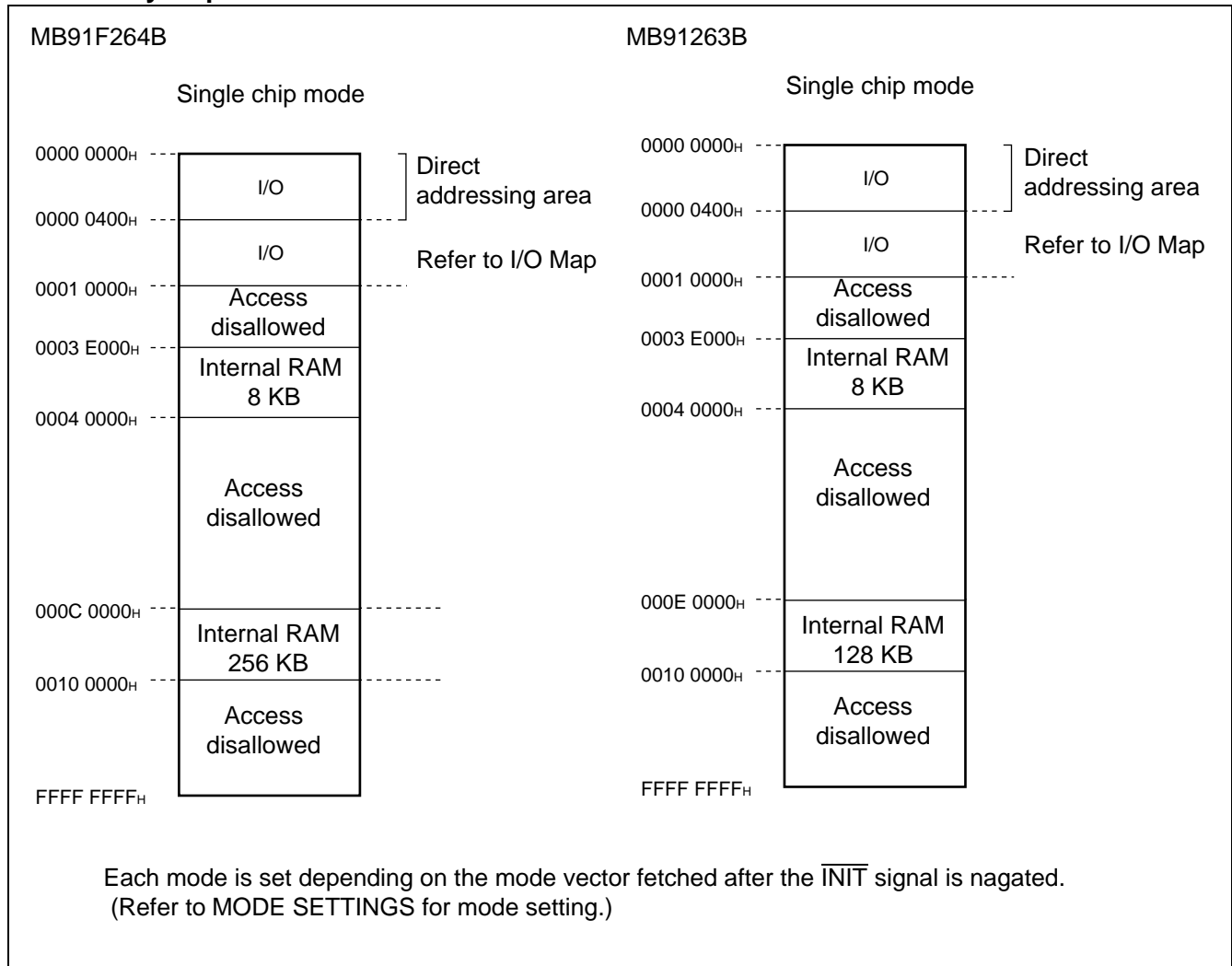



## ■ MODE SETTINGS

The FR family uses mode pins (MD2 to MD0) and a mode data to set the operation mode.

### 1. Mode Pins

The MD2, MD1, and MD0 pins specify how the mode vector fetch and reset vector fetch is performed. Setting is prohibited other than that shown in the following table.

Mode Pins			Mode name	Reset vector access area	Remarks
MD2	MD1	MD0			
0	0	0	Internal ROM mode vector	Internal	
1	0	0	Flash serial write mode	—	

### 2. Mode data

Data written to the internal mode register (MODR) by a mode vector fetch is called mode data. After an operation mode has been set in the mode register, the device operates in the operation mode. The mode data is set by all reset source. User programs cannot set data to the mode register.

<Details of mode data description>

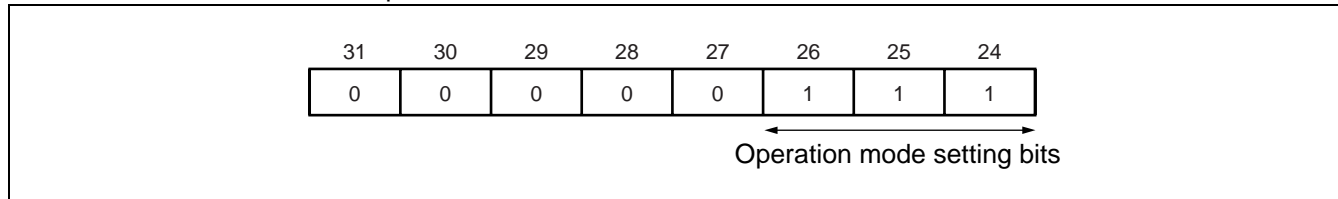

[bit31-24] Reserved bit

Be sure to set this bit to "00000111".

Operation is not guaranteed when any value other than "00000111" is set.

### 3. Note

Mode data set in the mode vector must be placed as byte data at 0X000FFF8.

Use the highest byte from bit 31 to bit 24 for placement as the FR family uses the big endian method for byte endian.

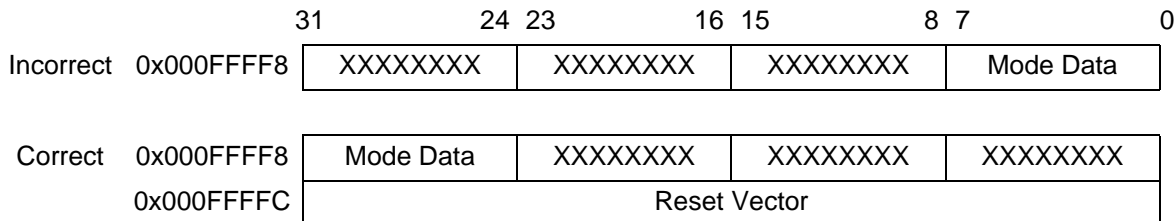

# MB91260B Series

## ■ I/O MAP

This shows the location of the various peripheral resource registers in the memory space.

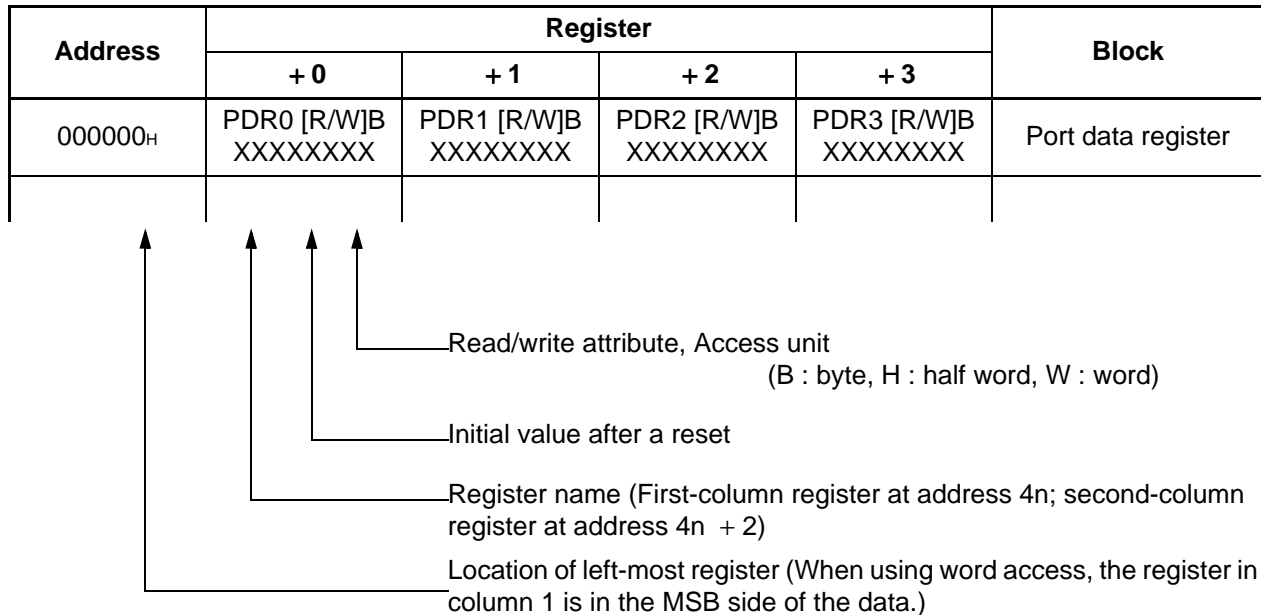

Note : Initial values of register bits are represented as follows :

- " 1 " : Initial Value : " 1 "
- " 0 " : Initial Value : " 0 "
- " X " : Initial Value : " undefined "
- " - " : No physical register at this location

# MB91260B Series

Address	Register				Block
	+ 0	+ 1	+ 2	+ 3	
000000 <sub>H</sub>	PDR0 [R/W] B XXXXXXXX	PDR1 [R/W] B XXXXXXXX	PDR2 [R/W] B XXXXXXXX	PDR3 [R/W] B XXXXXXXX	Port data register
000004 <sub>H</sub>	PDR4 [R/W] B XXXXXXXX	PDR5 [R/W] B XXXXXXXX	PDR6 [R/W] B ----XXXX	PDR7 [R/W] B XXXXXXXX	
000008 <sub>H</sub>	—				
00000C <sub>H</sub>	PDRC [R/W] B XXXXXXXX	PDRD [R/W] B -----XX	PDRE [R/W] B -----XX	—	
000010 <sub>H</sub>	PDRG [R/W] B --XXXXXX	—	—	—	
000014 <sub>H</sub> to 00003C <sub>H</sub>	—				Reserved
000040 <sub>H</sub>	EIRR0 [R/W] B, H, W 00000000	ENIR0 [R/W] B, H, W 00000000	ELVR0 [R/W] B, H, W 00000000 00000000		External interrupt (INT0 to INT7)
000044 <sub>H</sub>	DICR [R/W] B, H, W -----0	HRCL [R/W, R] B, H, W 0--11111	—	—	Delay interrupt/ Hold request
000048 <sub>H</sub>	TMRLR0 [W] H, W XXXXXXXXXX XXXXXXXXX		TMRO [R] H, W XXXXXXXXXX XXXXXXXXX		Reload timer 0
00004C <sub>H</sub>	—		TMCSR0 [R/W, R] B, H, W ---00000 00000000		
000050 <sub>H</sub>	TMRLR1 [W] H, W XXXXXXXXXX XXXXXXXXX		TMR1 [R] H, W XXXXXXXXXX XXXXXXXXX		Reload timer 1
000054 <sub>H</sub>	—		TMCSR1 [R/W, R] B, H, W ---00000 00000000		
000058 <sub>H</sub>	TMRLR2 [W] H, W XXXXXXXXXX XXXXXXXXX		TMR2 [R] H, W XXXXXXXXXX XXXXXXXXX		Reload timer 2
00005C <sub>H</sub>	—		TMCSR2 [R/W, R] B, H, W ---00000 00000000		
000060 <sub>H</sub>	SSR0 [R/W, R] B, H, W 00001000	SIDR0 [R]/SODR0[W] B, H, W XXXXXXXXXX	SCR0 [R/W] B, H, W 00000100	SMR0 [R/W, W] B, H, W 00--0-0-	UART0
000064 <sub>H</sub>	UTIM0 [R] H / UTIMR0 [W] H 00000000 00000000		DRCL0 [W] B -----	UTIMC0 [R/W] B 0--00001	U-timer 0
000068 <sub>H</sub>	SSR1 [R/W, R] B, H, W 00001000	SIDR1 [R]/SODR1[W] B, H, W XXXXXXXXXX	SCR1 [R/W] B, H, W 00000100	SMR1 [R/W] B, H, W 00--0-0-	UART1
00006C <sub>H</sub>	UTIM1 [R] H / UTIMR1 [W] H 00000000 00000000		DRCL1 [W] B -----	UTIMC1 [R/W] B 0--00001	U-timer 1
000070 <sub>H</sub>	SSR2 [R/W, R] B, H, W 00001000	SIDR2 [R]/SODR2[W] B, H, W XXXXXXXXXX	SCR2 [R/W] B, H, W 00000100	SMR2 [R/W] B, H, W 00--0-0-	UART2
000074 <sub>H</sub>	UTIM2 [R] H / UTIMR2 [W] H 00000000 00000000		DRCL2 [W] B -----	UTIMC2 [R/W] B 0--00001	U-timer 2

(Continued)

# MB91260B Series

Address	Register				Block
	+ 0	+ 1	+ 2	+ 3	
000078 <sub>H</sub>	ADCH0 [R/W] B, H, W XX000000	ADMD0 [R/W] B, H, W 00001111	ADCD01 [R] B, H, W XXXXXXXXXX	ADCD00 [R] B, H, W XXXXXXXXXX	A/D converter 0/ AICR0
00007C <sub>H</sub>	ADCS0 [R/W, W] B, H, W 00000X00	—	AICR0 [R/W] B, H, W 00000000	—	
000080 <sub>H</sub>	ADCH1 [R/W] B, H, W XXXX0XX0	ADMD1 [R/W] B, H, W 00001111	ADCD11 [R] B, H, W XXXXXXXXXX	ADCD10 [R] B, H, W XXXXXXXXXX	A/D converter 1/ AICR1
000084 <sub>H</sub>	ADCS1 [R/W, W] B, H, W 00000X00	—	AICR1 [R/W] B, H, W -----00	—	
000088 <sub>H</sub>	ADCH2 [R/W] B, H, W XXXX0XX0	ADMD2 [R/W] B, H, W 00001111	ADCD21 [R] B, H, W XXXXXXXXXX	ADCD20 [R] B, H, W XXXXXXXXXX	A/D converter 2/ AICR2
00008C <sub>H</sub>	ADCS2 [R/W, W] B, H, W 00000X00	—	AICR2 [R/W] B, H, W -----00	—	
000090 <sub>H</sub>	OCCPBH0, OCCPBL0[W]/ OCCPH0, OCCPL0[R] H, W 00000000 00000000		OCCPBH1, OCCPBL1[W]/ OCCPH1, OCCPL1 [R] H, W 00000000 00000000		OCU
000094 <sub>H</sub>	OCCPBH2, OCCPBL2[W]/ OCCPH2, OCCPL2 [R] H, W 00000000 00000000		OCCPBH3, OCCPBL3[W]/ OCCPH3, OCCPL3 [R] H, W 00000000 00000000		
000098 <sub>H</sub>	OCCPBH4, OCCPBL4[W]/ OCCPH4, OCCPL4 [R] H, W 00000000 00000000		OCCPBH5, OCCPBL5[W]/ OCCPH5, OCCPL5 [R] H, W 00000000 00000000		
00009C <sub>H</sub>	OCSH1 [R/W] B, H, W X1100000	OCSL0 [R/W] B, H, W 00001100	OCSH3 [R/W] B, H, W X1100000	OCSL2 [R/W] B, H, W 00001100	
0000A0 <sub>H</sub>	OCSH5 [R/W] B, H, W X1100000	OCSL4 [R/W] B, H, W 00001100	OCMOD [R/W] B, H, W XX000000	—	
0000A4 <sub>H</sub>	CPCLRBH, CPCLRBL[W]/ CPCLRH, CPCLRL[R] H, W 11111111 11111111		TCDTH, TCDTL [R/W] H, W 00000000 00000000		free-run timer
0000A8 <sub>H</sub>	TCCSH [R/W] B, H, W 00000000	TCCSL [R/W] B, H, W 01000000	—	ADTRGC [R/W] B, H, W XXXX0000	
0000AC <sub>H</sub>	IPCPH0, IPCPL0 [R] H, W XXXXXXXXXX XXXXXXXXX		IPCPH1, IPCPL1 [R] H, W XXXXXXXXXX XXXXXXXXX		ICU
0000B0 <sub>H</sub>	IPCPH2, IPCPL2 [R] H, W XXXXXXXXXX XXXXXXXXX		IPCPH3, IPCPL3 [R] H, W XXXXXXXXXX XXXXXXXXX		
0000B4 <sub>H</sub>	PICSH01 [W] B, H, W 000000--	PICSL01 [R/W] B, H, W 00000000	ICSH23 [R] B, H, W XXXXXXXX00	ICSL23 [R/W] B, H, W 00000000	
0000B8 <sub>H</sub>	EIRR1 [R/W] B, H, W -----00	ENIR1 [R/W] B, H, W -----00	ELVR1 [R/W] B, H, W -----0000		External interrupt (INT8, INT9)

(Continued)

# MB91260B Series

Address	Register				Block
	+ 0	+ 1	+ 2	+ 3	
0000BC <sub>H</sub>	TMRRH0, TMRRL0 [R/W] H, W XXXXXXXX XXXXXXXX		TMRRH1, TMRRL1 [R/W] H, W XXXXXXXX XXXXXXXX		Waveform generator
0000C0 <sub>H</sub>	TMRRH2, TMRRL2 [R/W] H, W XXXXXXXX XXXXXXXX		—	—	
0000C4 <sub>H</sub>	DTCR0 [R/W] B, H, W 00000000	DTCR1 [R/W] B, H, W 00000000	DTCR2 [R/W] B, H, W 00000000	—	
0000C8 <sub>H</sub>	—	SIGCR1 [R/W] B, H, W 10000000	—	SIGCR2 [R/W] B, H, W XXXXXXXX1	
0000CC <sub>H</sub>	ADCOMP0 [R/W] H, W 00000000 00000000		ADCOMP1 [R/W] H, W 00000000 00000000		A/D COMP
0000D0 <sub>H</sub>	ADCOMP2 [R/W] H, W 00000000 00000000		—	ADCOMP3 [R/W] B, H, W XXXXX000	
0000D4 <sub>H</sub> to 0000DC <sub>H</sub>	—				Reserved
0000E0 <sub>H</sub>	PWCSR0 [R/W, R] B, H, W 00000000 00000000		PWCR0 [R] H, W 00000000 00000000		PWC
0000E4 <sub>H</sub>	PWCSR1 [R/W, R] B, H, W 00000000 00000000		PWCR1 [R] H, W 00000000 00000000		
0000E8 <sub>H</sub>	—	PDIVR0 [R/W] B, H, W XXXXX000	—	PDIVR1 [R/W] B, H, W XXXXX000	
0000EC <sub>H</sub> to 000FC <sub>H</sub>	—				Reserved
000100 <sub>H</sub>	PRLH0 [R/W] B, H, W XXXXXXXX	PRLH1 [R/W] B, H, W XXXXXXXX	PRLH2 [R/W] B, H, W XXXXXXXX	PRLH3 [R/W] B, H, W XXXXXXXX	PPG
000104 <sub>H</sub>	PRLH4 [R/W] B, H, W XXXXXXXX	PRLH5 [R/W] B, H, W XXXXXXXX	PRLH6 [R/W] B, H, W XXXXXXXX	PRLH7 [R/W] B, H, W XXXXXXXX	
000108 <sub>H</sub>	PPGC0 [R/W] B, H, W 0000000X	PPGC1 [R/W] B, H, W 0000000X	PPGC2 [R/W] B, H, W 0000000X	PPGC3 [R/W] B, H, W 0000000X	
00010C <sub>H</sub>	PRLH8 [R/W] B, H, W XXXXXXXX	PRLH9 [R/W] B, H, W XXXXXXXX	PRLH10 [R/W] B, H, W XXXXXXXX	PRLH11 [R/W] B, H, W XXXXXXXX	
000110 <sub>H</sub>	PRLH12 [R/W] B, H, W XXXXXXXX	PRLH13 [R/W] B, H, W XXXXXXXX	PRLH14 [R/W] B, H, W XXXXXXXX	PRLH15 [R/W] B, H, W XXXXXXXX	
000114 <sub>H</sub>	PPGC4 [R/W] B, H, W 0000000X	PPGC5 [R/W] B, H, W 0000000X	PPGC6 [R/W] B, H, W W0000000X	PPGC7 [R/W] B, H, W 0000000X	
000118 <sub>H</sub>	PRLH16 [R/W] B, H, W XXXXXXXX	PRLH17 [R/W] B, H, W XXXXXXXX	PRLH18 [R/W] B, H, W XXXXXXXX	PRLH19 [R/W] B, H, W XXXXXXXX	
00011C <sub>H</sub>	PRLH20 [R/W] B, H, W XXXXXXXX	PRLH21 [R/W] B, H, W XXXXXXXX	PRLH22 [R/W] B, H, W XXXXXXXX	PRLH23 [R/W] B, H, W XXXXXXXX	
000120 <sub>H</sub>	PPGC8 [R/W] B, H, W 0000000X	PPGC9 [R/W] B, H, W 0000000X	PPGC10 [R/W] B, H, W 0000000X	PPGC11 [R/W] B, H, W 0000000X	

(Continued)

# MB91260B Series

Address	Register				Block
	+ 0	+ 1	+ 2	+ 3	
000124 <sub>H</sub>	PRLH12 [R/W] B, H, W XXXXXXXX	PRLL12 [R/W] B, H, W XXXXXXXX	PRLH13 [R/W] B, H, W XXXXXXXX	PRLL13 [R/W] B, H, W XXXXXXXX	PPG
000128 <sub>H</sub>	PRLH14 [R/W] B, H, W XXXXXXXX	PRLL14 [R/W] B, H, W XXXXXXXX	PRLH15 [R/W] B, H, W XXXXXXXX	PRLL15 [R/W] B, H, W XXXXXXXX	
00012C <sub>H</sub>	PPGC12 [R/W] B, H, W 0000000X	PPGC13 [R/W] B, H, W 0000000X	PPGC14 [R/W] B, H, W 0000000X	PPGC15 [R/W] B, H, W 0000000X	
000130 <sub>H</sub>	TRG [R/W] B, H, W 00000000 00000000		—	GATEC [R/W] B, H, W XXXXXX00	
000134 <sub>H</sub>	REVC [R/W] B, H, W 00000000 00000000		—	—	
000138 <sub>H</sub> to 0001FC <sub>H</sub>	—				Reserved
000200 <sub>H</sub>	DMACA0 [R/W] B, H, W *1 00000000 00000000 00000000 00000000				DMAC
000204 <sub>H</sub>	DMACB0 [R/W] B, H, W 00000000 00000000 00000000 00000000				
000208 <sub>H</sub>	DMACA1 [R/W] B, H, W *1 00000000 00000000 00000000 00000000				
00020C <sub>H</sub>	DMACB1 [R/W] B, H, W 00000000 00000000 00000000 00000000				
000210 <sub>H</sub>	DMACA2 [R/W] B, H, W *1 00000000 00000000 00000000 00000000				
000214 <sub>H</sub>	DMACB2 [R/W] B, H, W 00000000 00000000 00000000 00000000				
000218 <sub>H</sub>	DMACA3 [R/W] B, H, W *1 00000000 00000000 00000000 00000000				
00021C <sub>H</sub>	DMACB3 [R/W] B, H, W 00000000 00000000 00000000 00000000				
000220 <sub>H</sub>	DMACA4 [R/W] B, H, W *1 00000000 00000000 00000000 00000000				
000224 <sub>H</sub>	DMACB4 [R/W] B, H, W 00000000 00000000 00000000 00000000				
000228 <sub>H</sub> to 00023C <sub>H</sub>	—				Reserved
000240 <sub>H</sub>	DMACR [R/W] B 0XX00000 XXXXXXXX XXXXXXXX XXXXXXXX				DMAC
000244 <sub>H</sub> to 000398 <sub>H</sub>	—				Reserved

(Continued)

# MB91260B Series

Address	Register				Block
	+ 0	+ 1	+ 2	+ 3	
00039CH	—	—	—	—	Sum of products
0003A0H	DSP-PC [R/W] XXXXXXXX	DSP-CSR [R/W, R, W] 00000000	DSP-LY [R/W] XXXXXXXX XXXXXXXX		
0003A4H	DSP-OT0 [R] XXXXXXXX XXXXXXXX		DSP-OT1 [R] XXXXXXXX XXXXXXXX		
0003A8H	DSP-OT2 [R] XXXXXXXX XXXXXXXX		DSP-OT3 [R] XXXXXXXX XXXXXXXX		
0003ACH	—	—	—	—	
0003B0H	DSP-OT4 [R] XXXXXXXX XXXXXXXX		DSP-OT5 [R] XXXXXXXX XXXXXXXX		
0003B4H	DSP-OT6 [R] XXXXXXXX XXXXXXXX		DSP-OT7 [R] XXXXXXXX XXXXXXXX		
0003B8H to 0003ECH	—				Reserved
0003F0H	BSD0 [W] W XXXXXXXX XXXXXXXX XXXXXXXX XXXXXXXX				Bit search
0003F4H	BSD1 [R/W] W XXXXXXXX XXXXXXXX XXXXXXXX XXXXXXXX				
0003F8H	BSDC [W] W XXXXXXXX XXXXXXXX XXXXXXXX XXXXXXXX				
0003FCH	BSRR [R] XXXXXXXX XXXXXXXX XXXXXXXX XXXXXXXX				
000400H	DDR0 [R/W] B 00000000	DDR1 [R/W] B 00000000	DDR2 [R/W] B 00000000	DDR3 [R/W] B 00000000	Data direction register
000404H	DDR4 [R/W] B 00000000	DDR5 [R/W] B 00000000	DDR6 [R/W] B ----0000	DDR7 [R/W] B 00000000	
000408H	—	—	—	—	
00040CH	DDRC [R/W] B 00000000	DDRD [R/W] B -----00	DDRE [R/W] B -----00	—	
000410H	DDRG [R/W] B --000000	—	—	—	
000414H to 00041CH	—				Reserved
000420H	PFR0 [R/W] B 00000000	PFR1 [R/W] B -0000000	PFR2 [R/W] B --00-00-	—	Port function register
000424H	—	—	—	PFR7 [R/W] B -----00	
000428H	—	—	—	—	
00042CH	—	—	—	—	
000430H	PFRG [R/W] B --00--0-	—	—	—	

(Continued)

# MB91260B Series

Address	Register				Block
	+ 0	+ 1	+ 2	+ 3	
000434 <sub>H</sub> to 00043C <sub>H</sub>	—				Reserved
000440 <sub>H</sub>	ICR00 [R/W, R] B, H, W ----1111	ICR01 [R/W, R] B, H, W ----1111	ICR02 [R/W, R] B, H, W ----1111	ICR03 [R/W, R] B, H, W ----1111	Interrupt controller
000444 <sub>H</sub>	ICR04 [R/W, R] B, H, W ----1111	ICR05 [R/W, R] B, H, W ----1111	ICR06 [R/W, R] B, H, W ----1111	ICR07 [R/W, R] B, H, W ----1111	
000448 <sub>H</sub>	ICR08 [R/W, R] B, H, W ----1111	ICR09 [R/W, R] B, H, W ----1111	ICR10 [R/W, R] B, H, W ----1111	ICR11 [R/W, R] B, H, W ----1111	
00044C <sub>H</sub>	ICR12 [R/W, R] B, H, W ----1111	ICR13 [R/W, R] B, H, W ----1111	ICR14 [R/W, R] B, H, W ----1111	ICR15 [R/W, R] B, H, W ----1111	
000450 <sub>H</sub>	ICR16 [R/W, R] B, H, W ----1111	ICR17 [R/W, R] B, H, W ----1111	ICR18 [R/W, R] B, H, W ----1111	ICR19 [R/W, R] B, H, W ----1111	
000454 <sub>H</sub>	ICR20 [R/W, R] B, H, W ----1111	ICR21 [R/W, R] B, H, W ----1111	ICR22 [R/W, R] B, H, W ----1111	ICR23 [R/W, R] B, H, W ----1111	
000458 <sub>H</sub>	ICR24 [R/W, R] B, H, W ----1111	ICR25 [R/W, R] B, H, W ----1111	ICR26 [R/W, R] B, H, W ----1111	ICR27 [R/W, R] B, H, W ----1111	
00045C <sub>H</sub>	ICR28 [R/W, R] B, H, W ----1111	ICR29 [R/W, R] B, H, W ----1111	ICR30 [R/W, R] B, H, W ----1111	ICR31 [R/W, R] B, H, W ----1111	
000460 <sub>H</sub>	ICR32 [R/W, R] B, H, W ----1111	ICR33 [R/W, R] B, H, W ----1111	ICR34 [R/W, R] B, H, W ----1111	ICR35 [R/W, R] B, H, W ----1111	
000464 <sub>H</sub>	ICR36 [R/W, R] B, H, W ----1111	ICR37 [R/W, R] B, H, W ----1111	ICR38 [R/W, R] B, H, W ----1111	ICR39 [R/W, R] B, H, W ----1111	
000468 <sub>H</sub>	ICR40 [R/W, R] B, H, W ----1111	ICR41 [R/W, R] B, H, W ----1111	ICR42 [R/W, R] B, H, W ----1111	ICR43 [R/W, R] B, H, W ----1111	
00046C <sub>H</sub>	ICR44 [R/W, R] B, H, W ----1111	ICR45 [R/W, R] B, H, W ----1111	ICR46 [R/W, R] B, H, W ----1111	ICR47 [R/W, R] B, H, W ----1111	
000470 <sub>H</sub> to 00047C <sub>H</sub>	—				Reserved
000480 <sub>H</sub>	RSRR [R/W] B, H, W 10000000	STCR [R/W] B, H, W 00110011	TBCR [R/W] B, H, W 00XXXX00	CTBR [W] B, H, W XXXXXXXXXX	Clock control unit
000484 <sub>H</sub>	CLKR [R/W] B, H, W 00000000	WPR [W] B, H, W XXXXXXXXXX	DIVR0 [R/W] B, H, W 00000011	DIVR1 [R/W] B, H, W 00000000	
000488 <sub>H</sub> to 0005FC <sub>H</sub>	—				Reserved
000600 <sub>H</sub>	PCR0 [R/W] B 00000000	PCR1 [R/W] B 00000000	PCR2 [R/W] B 00000000	PCR3 [R/W] B 00-----	Pull-up Control
000604 <sub>H</sub>	PCR4 [R/W] B 00000000	PCR5 [R/W] B 00000000	PCR6 [R/W] B ----0000	PCR7 [R/W] B 00000000	
000608 <sub>H</sub>	—	—	—	—	
00060C <sub>H</sub>	—	—	—	—	

(Continued)



# MB91260B Series

Address	Register				Block
	+ 0	+ 1	+ 2	+ 3	
000610 <sub>H</sub>	PCRG [R/W] B --000000	—	—	—	Pull-up Control
000614 <sub>H</sub> to 000FFC <sub>H</sub>	—				Reserved
001000 <sub>H</sub>	DMASA0 [R/W] W 00000000 00000000 00000000 00000000				DMAC
001004 <sub>H</sub>	DMADA0 [R/W] W 00000000 00000000 00000000 00000000				
001008 <sub>H</sub>	DMASA1 [R/W] W 00000000 00000000 00000000 00000000				
00100C <sub>H</sub>	DMADA1 [R/W] W 00000000 00000000 00000000 00000000				
001010 <sub>H</sub>	DMASA2 [R/W] W 00000000 00000000 00000000 00000000				
001014 <sub>H</sub>	DMADA2 [R/W] W 00000000 00000000 00000000 00000000				
001018 <sub>H</sub>	DMASA3 [R/W] W 00000000 00000000 00000000 00000000				
00101C <sub>H</sub>	DMADA3 [R/W] W 00000000 00000000 00000000 00000000				
001020 <sub>H</sub>	DMASA4 [R/W] W 00000000 00000000 00000000 00000000				
001024 <sub>H</sub>	DMADA4 [R/W] W 00000000 00000000 00000000 00000000				
001028 <sub>H</sub> to 006FFC <sub>H</sub>	—				Reserved
007000 <sub>H</sub>	FLCR [R/W] 0110X000	—	—	—	FLASH
007004 <sub>H</sub>	FLWC [R/W] 00000011*2	—	—	—	
007008 <sub>H</sub>	—	—	—	—	
00700C <sub>H</sub>	—	—	—	—	
007010 <sub>H</sub>	—	—	—	—	
007014 <sub>H</sub> to 00BFFC <sub>H</sub>	—				Reserved

(Continued)

# MB91260B Series

(Continued)

Address	Register				Block
	+ 0	+ 1	+ 2	+ 3	
00C000H to 00C07CH	X-RAM (coefficient RAM) [R/W] 64 × 16 bit				Sum of products
00C080H to 00C0FC	Y-RAM (variable RAM) [R/W] 64 × 16 bit				
00C100H to 00C2FC	I-RAM (instruction RAM) [R/W] 256 × 16 bit				
00C300H to 00FFFC	—				Reserved

\*1 : The lower 16 bits (DTC[15: 0]) of DMACA0 to DMACA4 cannot be accessed in bytes.

\*2 : The initial value of 1FLWC (7004H) is "00010011<sub>B</sub>" on EVA tool.

Writing "00000011<sub>B</sub>" on the evaluation model has no effect on its operation.

Notes : • Do not excute Read Modify Write instructions on registers having a write-only bit.

• Data is undefined in reseved or (-) area.

## ■ INTERRUPT VECTOR

Interrupt source	Interrupt number		Interrupt level	Offset	TBR default address	RN
	10	16				
Reset	0	00	—	3FC <sub>H</sub>	000FFFFC <sub>H</sub>	—
Mode vector	1	01	—	3F8 <sub>H</sub>	000FFFF8 <sub>H</sub>	—
System reserved	2	02	—	3F4 <sub>H</sub>	000FFFF4 <sub>H</sub>	—
System reserved	3	03	—	3F0 <sub>H</sub>	000FFFF0 <sub>H</sub>	—
System reserved	4	04	—	3EC <sub>H</sub>	000FFFE <sub>C</sub>	—
System reserved	5	05	—	3E8 <sub>H</sub>	000FFFE8 <sub>H</sub>	—
System reserved	6	06	—	3E4 <sub>H</sub>	000FFFE4 <sub>H</sub>	—
Coprocessor absent trap	7	07	—	3E0 <sub>H</sub>	000FFFE0 <sub>H</sub>	—
Coprocessor error trap	8	08	—	3DC <sub>H</sub>	000FFFD <sub>C</sub>	—
INTE instruction	9	09	—	3D8 <sub>H</sub>	000FFFD8 <sub>H</sub>	—
Instruction break exception	10	0A	—	3D4 <sub>H</sub>	000FFFD4 <sub>H</sub>	—
Operand break trap	11	0B	—	3D0 <sub>H</sub>	000FFFD0 <sub>H</sub>	—
Step trace trap	12	0C	—	3CC <sub>H</sub>	000FFFC <sub>C</sub>	—
NMI request (tool)	13	0D	—	3C8 <sub>H</sub>	000FFFC8 <sub>H</sub>	—
Undefined instruction exception	14	0E	—	3C4 <sub>H</sub>	000FFFC4 <sub>H</sub>	—
NMI request	15	0F	15 (F <sub>H</sub> ) fixed	3C0 <sub>H</sub>	000FFFC0 <sub>H</sub>	—
External interrupt 0	16	10	ICR00	3BC <sub>H</sub>	000FFFB <sub>C</sub>	6
External interrupt 1	17	11	ICR01	3B8 <sub>H</sub>	000FFFB8 <sub>H</sub>	7
External interrupt 2	18	12	ICR02	3B4 <sub>H</sub>	000FFFB4 <sub>H</sub>	—
External interrupt 3	19	13	ICR03	3B0 <sub>H</sub>	000FFFB0 <sub>H</sub>	—
External interrupt 4	20	14	ICR04	3AC <sub>H</sub>	000FFFA <sub>C</sub>	—
External interrupt 5	21	15	ICR05	3A8 <sub>H</sub>	000FFFA8 <sub>H</sub>	—
External interrupt 6	22	16	ICR06	3A4 <sub>H</sub>	000FFFA4 <sub>H</sub>	—
External interrupt 7	23	17	ICR07	3A0 <sub>H</sub>	000FFFA0 <sub>H</sub>	—
Reload timer 0	24	18	ICR08	39C <sub>H</sub>	000FFF9 <sub>C</sub>	8
Reload timer 1	25	19	ICR09	398 <sub>H</sub>	000FFF98 <sub>H</sub>	9
Reload timer 2	26	1A	ICR10	394 <sub>H</sub>	000FFF94 <sub>H</sub>	10
UART0(Reception completed)	27	1B	ICR11	390 <sub>H</sub>	000FFF90 <sub>H</sub>	0
UART0 (RX completed)	28	1C	ICR12	38C <sub>H</sub>	000FFF8 <sub>C</sub>	3
DTTI	29	1D	ICR13	388 <sub>H</sub>	000FFF88 <sub>H</sub>	—
DMAC0 (end, error)	30	1E	ICR14	384 <sub>H</sub>	000FFF84 <sub>H</sub>	—
DMAC1 (end, error)	31	1F	ICR15	380 <sub>H</sub>	000FFF80 <sub>H</sub>	—
DMAC2/3/4 (end, error)	32	20	ICR16	37C <sub>H</sub>	000FFF7 <sub>C</sub>	—

(Continued)

# MB91260B Series

Interrupt source	Interrupt number		Interrupt level	Offset	TBR default address	RN
	10	16				
UART1(Reception completed)	33	21	ICR17	378 <sub>H</sub>	000FFF78 <sub>H</sub>	1
UART1 (RX completed)	34	22	ICR18	374 <sub>H</sub>	000FFF74 <sub>H</sub>	4
UART2 (Reception completed)	35	23	ICR19	370 <sub>H</sub>	000FFF70 <sub>H</sub>	2
UART2 (RX completed)	36	24	ICR20	36C <sub>H</sub>	000FFF6C <sub>H</sub>	5
SUM of products macro	37	25	ICR21	368 <sub>H</sub>	000FFF68 <sub>H</sub>	—
PPG0	38	26	ICR22	364 <sub>H</sub>	000FFF64 <sub>H</sub>	—
PPG1	39	27	ICR23	360 <sub>H</sub>	000FFF60 <sub>H</sub>	—
PPG2/3	40	28	ICR24	35C <sub>H</sub>	000FFF5C <sub>H</sub>	—
PPG4/5/6/7	41	29	ICR25	358 <sub>H</sub>	000FFF58 <sub>H</sub>	—
PPG8/9/10/11/12/13/14/15	42	2A	ICR26	354 <sub>H</sub>	000FFF54 <sub>H</sub>	—
External interrupt 8/9	43	2B	ICR27	350 <sub>H</sub>	000FFF50 <sub>H</sub>	—
Waveform0 (under flow)	44	2C	ICR28	34C <sub>H</sub>	000FFF4C <sub>H</sub>	—
Waveform1 (under flow)	45	2D	ICR29	348 <sub>H</sub>	000FFF48 <sub>H</sub>	—
Waveform2 (under flow)	46	2E	ICR30	344 <sub>H</sub>	000FFF44 <sub>H</sub>	—
Timebase timer overflow	47	2F	ICR31	340 <sub>H</sub>	000FFF40 <sub>H</sub>	—
Free-run timer (Compare clear)	48	30	ICR32	33C <sub>H</sub>	000FFF3C <sub>H</sub>	—
Free-run timer (zero detection)	49	31	ICR33	338 <sub>H</sub>	000FFF38 <sub>H</sub>	—
A/D0	50	32	ICR34	334 <sub>H</sub>	000FFF34 <sub>H</sub>	—
A/D1	51	33	ICR35	330 <sub>H</sub>	000FFF30 <sub>H</sub>	—
A/D2	52	34	ICR36	32C <sub>H</sub>	000FFF2C <sub>H</sub>	—
PWC0 (measurment completed)	53	35	ICR37	328 <sub>H</sub>	000FFF28 <sub>H</sub>	—
PWC1 (measurment completed)	54	36	ICR38	324 <sub>H</sub>	000FFF24 <sub>H</sub>	—
PWC0 (overflow)	55	37	ICR39	320 <sub>H</sub>	000FFF20 <sub>H</sub>	—
PWC1 (overflow)	56	38	ICR40	31C <sub>H</sub>	000FFF1C <sub>H</sub>	—
ICU0 (capture)	57	39	ICR41	318 <sub>H</sub>	000FFF18 <sub>H</sub>	—
ICU1 (capture)	58	3A	ICR42	314 <sub>H</sub>	000FFF14 <sub>H</sub>	—
ICU2/3 (capture)	59	3B	ICR43	310 <sub>H</sub>	000FFF10 <sub>H</sub>	—
OCU0/1 (match)	60	3C	ICR44	30C <sub>H</sub>	000FFF0C <sub>H</sub>	—
OCU2/3 (match)	61	3D	ICR45	308 <sub>H</sub>	000FFF08 <sub>H</sub>	—
OCU4/5 (match)	62	3E	ICR46	304 <sub>H</sub>	000FFF04 <sub>H</sub>	—
Delay interrupt source bit	63	3F	ICR47	300 <sub>H</sub>	000FFF00 <sub>H</sub>	—
System reserved (Used by REALOS)	64	40	—	2FC <sub>H</sub>	000FFEFC <sub>H</sub>	—
System reserved (Used by REALOS)	65	41	—	2F8 <sub>H</sub>	000FFEFC <sub>H</sub>	—

(Continued)

# MB91260B Series

(Continued)

Interrupt source	Interrupt number		Interrupt level	Offset	TBR default address	RN
	10	16				
System reserved	66	42	—	2F4 <sub>H</sub>	000FFE <sub>F4H</sub>	—
System reserved	67	43	—	2F0 <sub>H</sub>	000FFE <sub>F0H</sub>	—
System reserved	68	44	—	2EC <sub>H</sub>	000FFE <sub>ECH</sub>	—
System reserved	69	45	—	2E8 <sub>H</sub>	000FFE <sub>E8H</sub>	—
System reserved	70	46	—	2E4 <sub>H</sub>	000FFE <sub>E4H</sub>	—
System reserved	71	47	—	2E0 <sub>H</sub>	000FFE <sub>E0H</sub>	—
System reserved	72	48	—	2DC <sub>H</sub>	000FFE <sub>DC<sub>H</sub></sub>	—
System reserved	73	49	—	2D8 <sub>H</sub>	000FFE <sub>D8<sub>H</sub></sub>	—
System reserved	74	4A	—	2D4 <sub>H</sub>	000FFE <sub>D4<sub>H</sub></sub>	—
System reserved	75	4B	—	2D0 <sub>H</sub>	000FFE <sub>D0<sub>H</sub></sub>	—
System reserved	76	4C	—	2CC <sub>H</sub>	000FFE <sub>CC<sub>H</sub></sub>	—
System reserved	77	4D	—	2C8 <sub>H</sub>	000FFE <sub>C8<sub>H</sub></sub>	—
System reserved	78	4E	—	2C4 <sub>H</sub>	000FFE <sub>C4<sub>H</sub></sub>	—
System reserved	79	4F	—	2C0 <sub>H</sub>	000FFE <sub>C0<sub>H</sub></sub>	—
Used by INT instruction	80 to 255	50 to FF	—	2BC <sub>H</sub> to 000 <sub>H</sub>	000FFE <sub>BC<sub>H</sub></sub> to 000FFC <sub>00<sub>H</sub></sub>	—

## ■ PIN STATUS IN EACH CPU STATE

Terms used as the status of pins mean as follows.

- Input enabled
- Indicates that the input function can be used.
- Input 0 fixed
- Indicates that the input level has been internally fixed to be 0 to prevent leakage when the input is released.
- Output Hi-Z
- Means the placing of a pin in a high impedance state by preventing the transistor for driving the pin from driving.
- Output is maintained.
- Indicates the output in the output state existing immediately before this mode is established.
- If the device enters this mode with an internal output peripheral operating or while serving as an output port, the output is performed by the internal peripheral or the port output is maintained, respectively.
- State existing immediately before is maintained.
- When the device serves for output or input immediately before entering this mode, the device maintains the output or is ready for the input, respectively.

# MB91260B Series

- List of pin status (single chip mode)

Pin no.		Pin name	Function	At initializing		At sleep mode	At Stop mode				
QFP	LQFP			$\overline{INIT} = L^{*1}$	$\overline{INIT} = H^{*2}$		Hi-Z = 0	Hi-Z = 1			
1	99	P23	SIN1	Output Hi-Z/ Input disabled	Output Hi-Z/ Input disabled	Retention of the immediately prior state	Retention of the immediately prior state	Output Hi-Z/ Input 0 fixed			
2	100	P24	SOT1			Retention of the immediately prior state	Retention of the immediately prior state	Output Hi-Z/ Input 0 fixed			
3	1	P25	SCK1			Input enabled	Input enabled	Input enabled			
4, 5	2, 3	P26, P27	INT6, INT7			Retention of the immediately prior state	Retention of the immediately prior state	Output Hi-Z/ Input 0 fixed			
6 to 9	4 to 7	P50 to P53	Ports			Retention of the immediately prior state	Retention of the immediately prior state	Output Hi-Z/ Input 0 fixed			
10	8	P54	INT0			Input enabled	Input enabled	Input enabled			
11	9	P55	INT1								
12	10	P56	INT2								
13	11	P57	INT3								
14	12	PG0	CKI/INT4								
15	13	PG1	PPG0/INT5								
16	14	PG2	Ports								
20	18	PG3	SIN2								
21	19	PG4	SOT2								
22	20	PG5	SCK2								
23 to 30	21 to 28	P40 to P47	Ports						Retention of the immediately prior state	Retention of the immediately prior state	Output Hi-Z/ Input 0 fixed
31, 32	29, 30	PE1, PE0	AN11, AN10								
38, 39	36, 37	PD1, PD0	AN9, AN8								
41 to 48	39 to 46	PC7 to PC0	AN7 to AN0								
51 to 56	49 to 54	P30 to P35	RTO0 to RTO5								
57, 58	55, 56	P36, P37	IC0, IC1								
59, 60	57, 58	P60, P61	IC2, IC3								
61, 62	59, 60	P62, P63	INT8, INT9			Input enabled	Input enabled	Input enabled			

(Continued)

# MB91260B Series

(Continued)

P : Selection of general purpose port, F : Selection of specified function

Pin no.		Pin name	Function	At initializing		At sleep mode	At Stop mode	
QFP	LQFP			$\overline{\text{INIT}} = \text{L}^{*1}$	$\overline{\text{INIT}} = \text{H}^{*2}$		Hi-Z = 0	Hi-Z = 1
63, 64	61, 62	P70, P71	TOT1, TOT2	Output Hi-Z/ input disabled	Output Hi-Z/ input disabled	Retention of the immediately prior state	Retention of the immediately prior state	Output Hi-Z/ Input 0 fixed
65	63	P72	DTTI					
66	64	P73	PWI0					
69	67	P74	PWI1					
70	68	P75	ADTG0					
71	69	P76	ADTG1					
72	70	P77	ADTG2					
73	71	NMI	NMI	Input enabled	Input enabled	Input enabled	Input enabled	Input enabled
78	76	P00	PPG1	Output Hi-Z/ input disabled	output Hi-Z/ input disabled	Retention of the immediately prior state	Retention of the immediately prior state	Ouptut Hi-Z/ input 0 fixed
79	77	P01	PPG2					
80	78	P02	PPG3					
81	79	P03	PPG4					
82	80	P04	PPG5					
83	81	P05	PPG6					
84	82	P06	PPG7					
85	83	P07	PPG8					
86	84	P10	PPG9					
87	85	P11	PPG10					
88	86	P12	PPG11					
89	87	P13	PPG12					
90	88	P14	PPG13					
91	89	P15	PPG14					
96	94	P16	PPG15					
97	95	P17	Ports					
98	96	P20	SIN0					
99	97	P21	SOT0					
100	98	P22	SCK0					

\*1 :  $\overline{\text{INIT}} = \text{L}$  : Indicates the pin status with  $\overline{\text{INIT}}$  remaining at the "L" level.

\*2 :  $\overline{\text{INIT}} = \text{H}$  : Indicates the pin status existing immediately after  $\overline{\text{INIT}}$  transition from "L" to "H" level.



## ■ ELECTRICAL CHARACTERISTICS

### 1. Absolute Maximum Ratings

( $V_{SS} = AV_{SS} = 0\text{ V}$ )

Parameter	Symbol	Rating		Unit	Remarks
		Min	Max		
Power supply voltage	$V_{CC}$	$V_{SS} - 0.5$	$V_{SS} + 6.0$	V	
Analog power supply voltage	$AV_{CC}$	$V_{SS} - 0.5$	$V_{SS} + 6.0$	V	*1
Analog reference voltage	$AVRH$	$V_{SS} - 0.5$	$V_{SS} + 6.0$	V	*1
Input voltage	$V_I$	$V_{SS} - 0.3$	$V_{CC} + 0.3$	V	
Analog pin input voltage	$V_{IA}$	$V_{SS} - 0.3$	$AV_{CC} + 0.3$	V	
Output voltage	$V_O$	$V_{SS} - 0.3$	$V_{CC} + 0.3$	V	
L level maximum output current	$I_{OL}$	—	10	mA	*2
L level average output current	$I_{OLAV}$	—	8	mA	*3
L level total maximum output current	$\Sigma I_{OL}$	—	100	mA	
L level total average output current	$\Sigma I_{OLAV}$	—	50	mA	*4
H level maximum output current	$I_{OH}$	—	- 10	mA	*2
H level average output current	$I_{OHAV}$	—	- 4	mA	*3
H level total maximum output current	$\Sigma I_{OH}$	—	- 50	mA	
H level total average output current	$\Sigma I_{OHAV}$	—	- 20	mA	*4
Power consumption	$P_D$	—	600	mW	FLASH product
			600		MASK product $T_a \leq +85\text{ °C}$
			360		MASK product $T_a \leq +105\text{ °C}$ *5
Operating temperature	$T_a$	- 40	+ 105	°C	MASK product (at single chip operating)
		- 40	+ 85	°C	FLASH product (at single chip operating)
Storage temperature	$T_{stg}$	- 55	125	°C	

\*1 : Be careful not to exceed  $V_{CC} + 0.3\text{ V}$ , for example, when the power is turned on.

Be careful not to let  $AV_{CC}$  exceed  $V_{CC}$ , for example, when the power is turned on.

\*2 : The maximum output current is the peak value for a single pin.

\*3 : The average output current is the average current for a single pin over a period of 100 ms.

\*4 : The total average output current is the average current for all pins over a period of 100 ms.

\*5 : For use at  $T_a = +105\text{ °C}$ , lower the operating frequency to reduce power consumption.

**WARNING:** Semiconductor devices can be permanently damaged by application of stress (voltage, current, temperature, etc.) in excess of absolute maximum ratings. Do not exceed these ratings.

# MB91260B Series

## 2. Recommended Operating Conditions

(V<sub>SS</sub> = AV<sub>SS</sub> = 0 V)

Parameter	Symbol	Value		Unit	Remarks
		Min	Max		
Power supply voltage	V <sub>CC</sub>	4.0	5.5	V	At normal operating
Analog power supply voltage	AV <sub>CC</sub>	V <sub>SS</sub> + 4.0	V <sub>SS</sub> + 5.5	V	
Analog reference voltage	AVRH0	AV <sub>SS</sub>	AV <sub>CC</sub>	V	For A/D converter 0
	AVRH1	AV <sub>SS</sub>	AV <sub>CC</sub>	V	For A/D converter 1
	AVRH2	AV <sub>SS</sub>	AV <sub>CC</sub>	V	For A/D converter 2
Operating temperature	T <sub>a</sub>	- 40	+ 105	°C	MASK product (at single chip operation)
		- 40	+ 85	°C	FLASH product (at single chip operation)

**WARNING:** The recommended operating conditions are required in order to ensure the normal operation of the semiconductor device. All of the device's electrical characteristics are warranted when the device is operated within these ranges.

Always use semiconductor devices within their recommended operating condition ranges. Operation outside these ranges may adversely affect reliability and could result in device failure.

No warranty is made with respect to uses, operating conditions, or combinations not represented on the data sheet. Users considering application outside the listed conditions are advised to contact their FUJITSU representatives beforehand.

# MB91260B Series

## 3. DC Characteristics

( $V_{CC} = 4.0$  to  $5.5$  V,  $V_{SS} = AV_{SS} = 0$  V)

Parameter	Symbol	Pin	Conditions	Value			Unit	Remarks
				Min	Typ	Max		
"H" level input voltage	$V_{IH}$	Other than hysteresis input pin	—	$0.8 \times V_{CC}$	—	$V_{CC}$	V	
	$V_{IHS}$	Hysteresis input pin	—	$V_{CC} - 0.4$	—	$V_{CC}$	V	
Input Low Voltage	$V_{IL}$	Other than hysteresis input pin	—	$V_{SS}$	—	$0.2 \times V_{CC}$	V	
	$V_{ILS}$	Hysteresis input pin	—	$V_{SS}$	—	$V_{SS} + 0.4$	V	
"H" level output voltage	$V_{OH}$	Other than port 30 to 35	$V_{CC} = 5.0$ V, $I_{OH} = 4.0$ mA	$V_{CC} - 0.5$	—	—	V	
	$V_{OH2}$	Port 30 to 35	$V_{CC} = 5.0$ V, $I_{OH} = 8.0$ mA	$V_{CC} - 0.7$	—	—	V	
Output Low Voltage	$V_{OL}$	Other than port 30 to 35	$V_{CC} = 5.0$ V, $I_{OL} = 4.0$ mA	—	—	0.4	V	
	$V_{OL2}$	Port 30 to 35	$V_{CC} = 5.0$ V, $I_{OL} = 12$ mA	—	—	0.6	V	
Input leak current	$I_{LI}$	—	$V_{CC} = 5.0$ V, $V_{SS} \leq V_I \leq V_{CC}$	-5	—	5	$\mu$ A	
Pullup resistance	$R_{PULL}$	$\overline{INIT}$ , Pull-up pin	—	—	50	—	k $\Omega$	
Power supply current	$I_{CC}$	$V_{CC}$	$V_{CC} = 5.0$ V, 33 MHz	—	90	100	mA	
	$I_{CCS}$	$V_{CC}$	$V_{CC} = 5.0$ V, 33 MHz	—	60	80	mA	At SLEEP
	$I_{CCH}$	$V_{CC}$	$V_{CC} = 5.0$ V, $T_a = +25$ °C	—	300	—	$\mu$ A	At STOP
Input capacitance	$C_{IN}$	Other than $V_{CC}$ , $V_{SS}$ , $AV_{CC}$ , $AV_{SS}$ , AVRH0, 1, 2	—	—	10	—	pF	

# MB91260B Series

## 4. FLASH MEMORY write/erase characteristics

Parameter	Conditions	Value			Unit	Remarks
		Min	Typ	Max		
Sector erase time	Ta = +25 °C, Vcc = 5.0 V	—	1	15	s	Not including time for internal writing before deletion.
Chip erase time	Ta = +25 °C, Vcc = 5.0 V	—	10	—	s	Not including time for internal writing before deletion.
Byte write time	Ta = +25 °C, Vcc = 5.0 V	—	8	3,600	μs	Not including system-level overhead time.
Chip write time	Ta = +25 °C, Vcc = 5.0 V	—	2.1	—	s	Not including system-level overhead time.
Erase/write cycle		10,000	—	—	Cycle	

## 5. AC Characteristics

### (1) Clock Timing Ratings

( $V_{CC} = 4.0$  to  $5.5$  V,  $V_{SS} = AV_{SS} = 0$  V)

Parameter	Symbol	Pin	Conditions	Value			Unit	Remarks
				Min	Typ	Max		
Clock frequency	$f_c$	X0 X1	—	3.6	—	12	MHz	For using the PLL within the self-oscillation enabled range, set the multiplier for the internal clock not to let the operating frequency exceed 33 MHz.
Clock cycle time	$t_c$	X0 X1		83.3	—	278	ns	
Internal operating clock frequency	$f_{CP}$	—	When 4.125 MHz is input as the X0 clock frequency and $\times 8$ multiplication is set for the PLL of the oscillator circuit.	2.06*	—	33	MHz	CPU
	$f_{CPP}$			2.06*	—	33	MHz	Peripheral
Internal operating clock cycle time	$t_{CP}$	—		30.3	—	485*	ns	CPU
	$t_{CPP}$			30.3	—	485*	ns	Peripheral

\* : The values assume a gear cycle of 1/16.

#### • Conditions for measuring the clock timing ratings

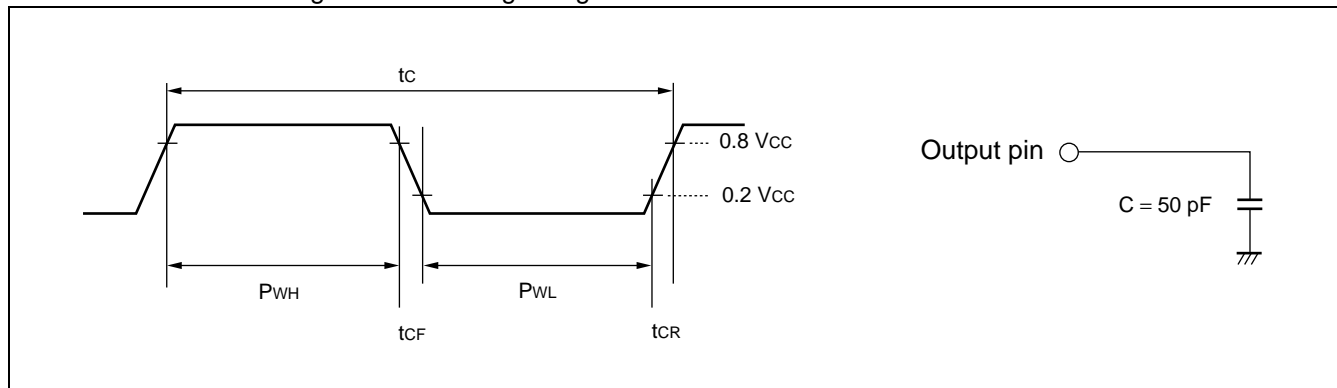

# MB91260B Series

## • Operation Assurance Range

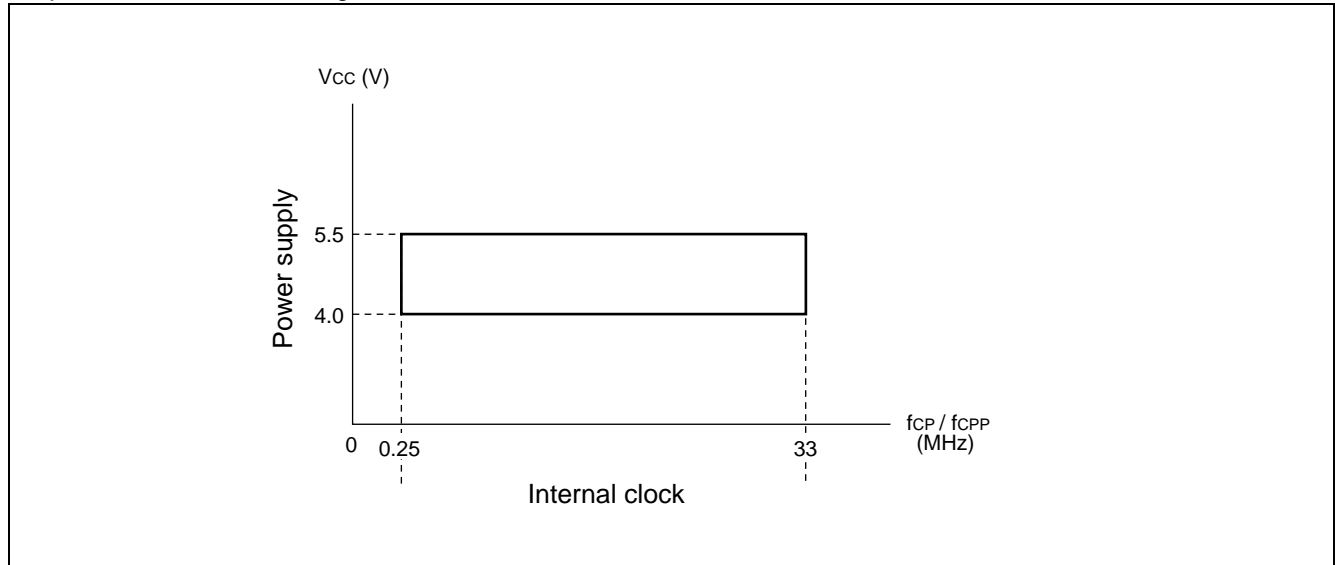

## • Internal clock setting range

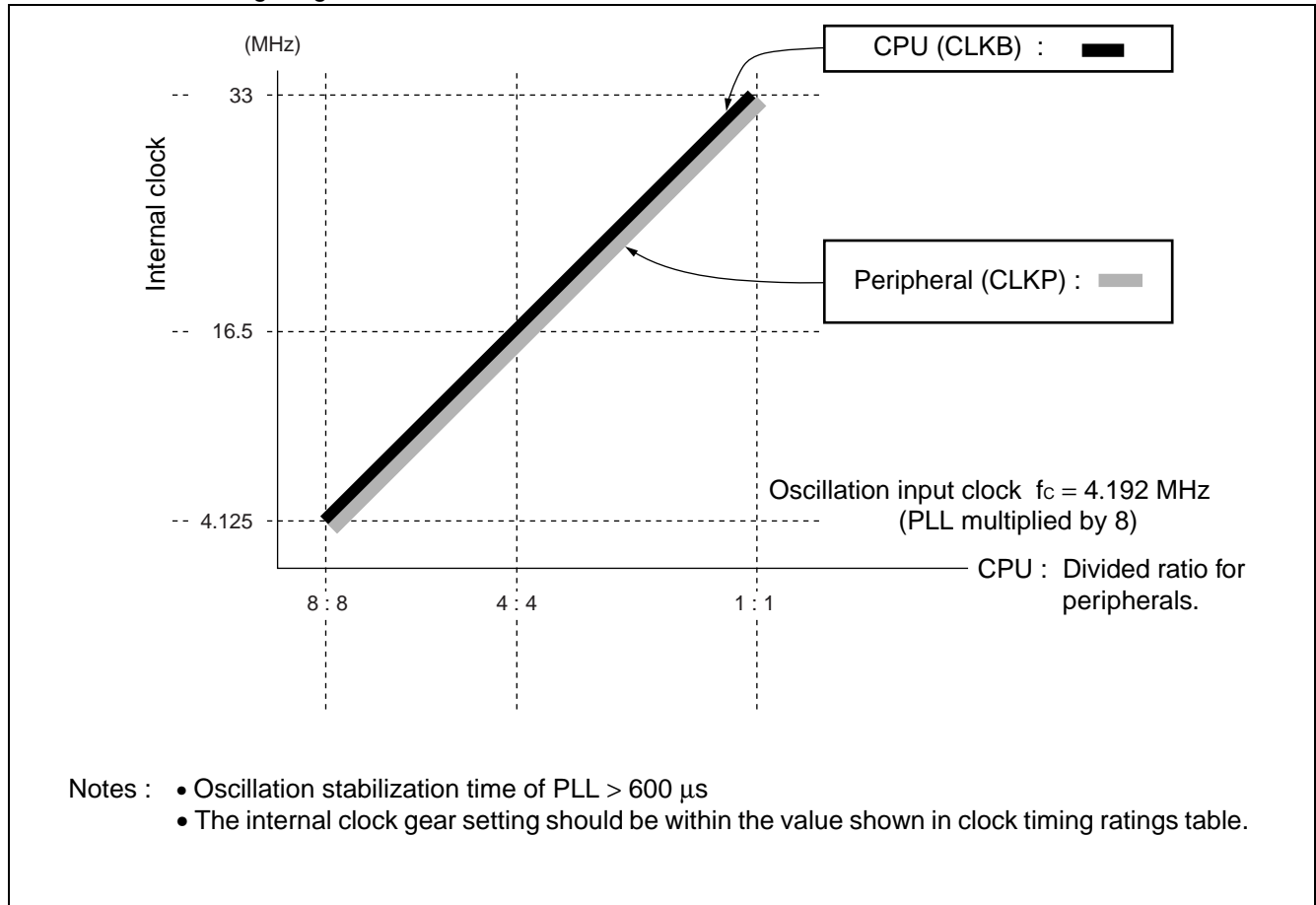

## (2) Reset Input

( $V_{CC} = 4.0$  to  $5.5$  V,  $V_{SS} = AV_{SS} = 0$  V)

Parameter	Symbol	Pin	Conditions	Value		Unit	Remarks
				Min	Max		
Init input time (at power-on and STOP mode)	$t_{INTL}$	INIT	—	Oscillation time of oscillator + $t_c \times 10$	—	ns	
Init input time (other than the above)				$t_c \times 10$	—	ns	

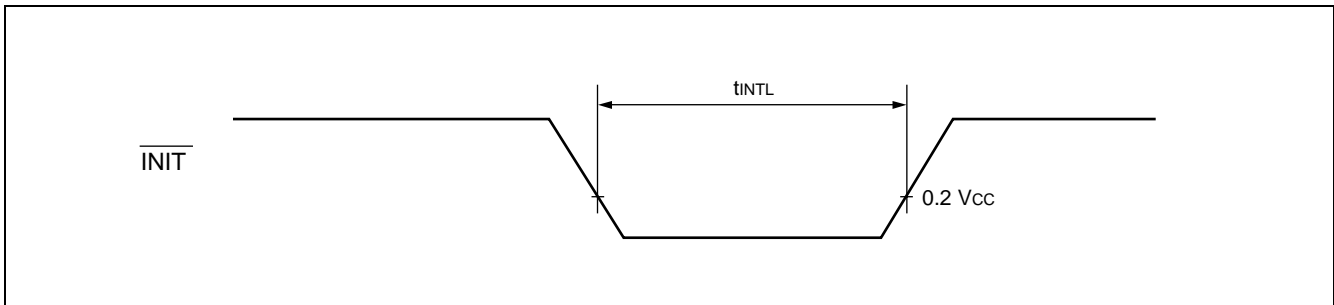

# MB91260B Series

## (3) UART Timing

(V<sub>CC</sub> = 4.0 to 5.5 V, V<sub>SS</sub> = AV<sub>SS</sub> = 0 V)

Parameter	Symbol	Pin	Conditions	Value		Unit	Remarks
				Min	Max		
Serial clock cycle time	t <sub>SCYC</sub>	SCK0 to SCK2	Internal shift clock mode	8 t <sub>CYCP</sub>	—	ns	
SCK ↓ → SOT delay time	t <sub>SLOV</sub>	SCK0 to SCK2, SOT0 to SOT2		- 80	80	ns	
Valid SIN → SCK ↑	t <sub>IVSH</sub>	SCK0 to SCK2, SIN0 to SIN2		100	—	ns	
SCK ↑ → valid SIN hold time	t <sub>SHIX</sub>	SCK0 to SCK2, SIN0 to SIN2		60	—	ns	
Serial clock H pulse width	t <sub>SHSL</sub>	SCK0 to SCK2	External shift clock mode	4 t <sub>CYCP</sub>	—	ns	
Serial clock L pulse width	t <sub>LSLH</sub>	SCK0 to SCK2		4 t <sub>CYCP</sub>	—	ns	
SCK ↓ → SOT delay time	t <sub>SLOV</sub>	SCK0 to SCK2, SOT0 to SOT2		—	150	ns	
Valid SIN → SCK ↑	t <sub>IVSH</sub>	SCK0 to SCK2, SIN0 to SIN2		60	—	ns	
SCK ↑ → valid SIN hold time	t <sub>SHIX</sub>	SCK0 to SCK2, SIN0 to SIN2		60	—	ns	

- Notes :
- There are the AC ratings for CLK synchronous mode.
  - t<sub>CYCP</sub> indicates the peripheral clock cycle time.



• Internal shift clock mode

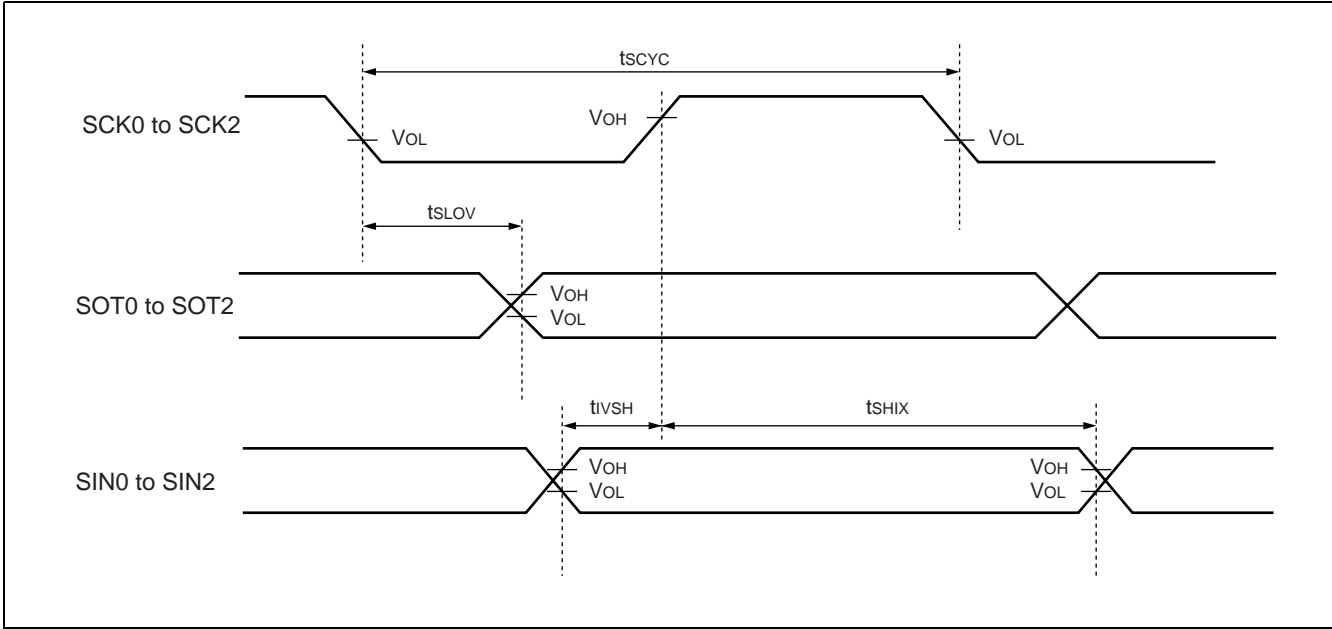

• External shift clock mode

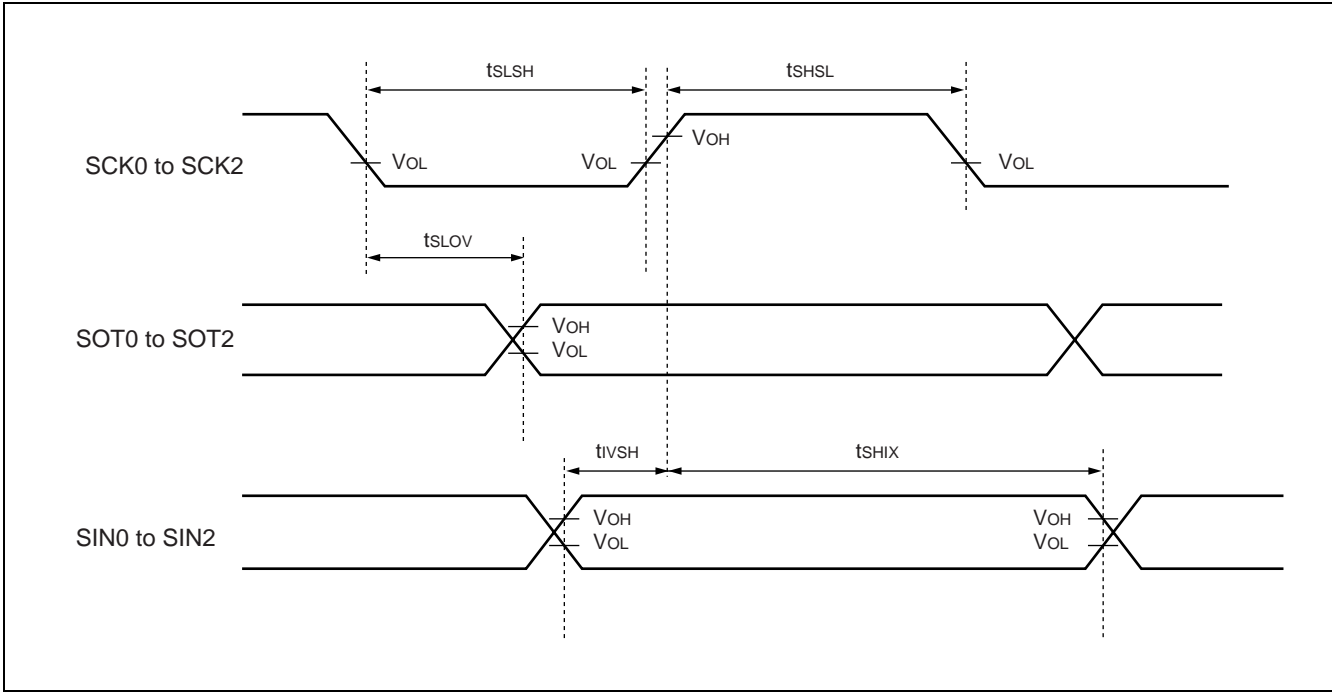

# MB91260B Series

## (4) Free-run Timer Clock, PWC Input and Reload Timer Trigger Timing

( $V_{CC} = 4.0$  to  $5.5$  V,  $V_{SS} = AV_{SS} = 0$  V)

Parameter	Symbol	Pin	Conditions	Value		Unit	Remarks
				Min	Max		
Input pulse width	$t_{TIWH}$ $t_{TIWL}$	CKI PW10, PW11 TIN0 to TIN2	—	4 $t_{CYCP}$	—	ns	

Note :  $t_{CYCP}$  indicates the peripheral clock cycle time.

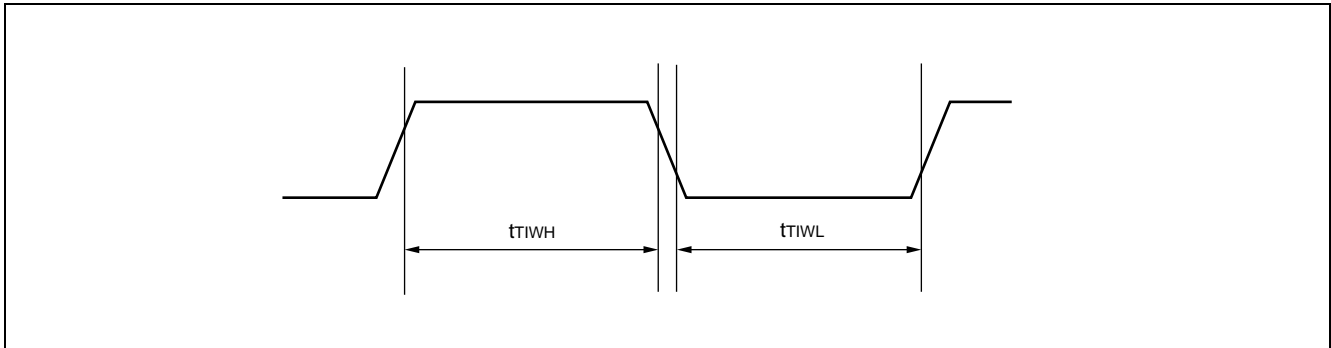

**(5) Trigger Input Timing**

( $V_{CC} = 4.0$  to  $5.5$  V,  $V_{SS} = AV_{SS} = 0$  V)

Parameter	Symbol	Pin	Conditions	Value		Unit	Remarks
				Min	Max		
Input capture trigger input	$t_{INP}$	IC0 to IC3	—	$5 t_{CYCP}$	—	ns	
A/D activation trigger input	$t_{ATGX}$	ADTG0 to ADTG2	—	$5 t_{CYCP}$	—	ns	

Note :  $t_{CYCP}$  indicates the peripheral clock cycle time.

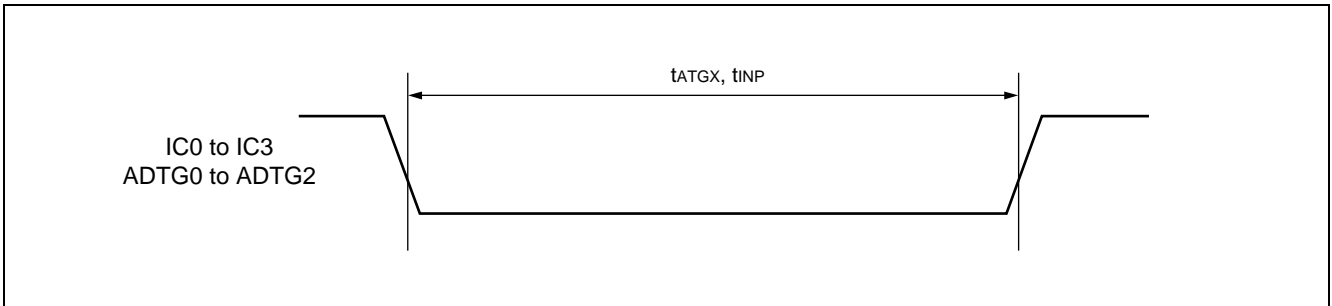

# MB91260B Series

## 6. Electrical Characteristics for the A/D Converter

( $V_{CC} = AV_{CC} = 5.0\text{ V}$ ,  $V_{SS} = AV_{SS} = 0\text{ V}$ )

Parameter	Symbol	Pin	Value			Unit	Remarks
			Min	Typ	Max		
Resolution	—	—	—	—	10	bit	
Total error* <sup>1</sup>	—	—	- 4	—	4	LSB	At $AVRHn^{*4} = 5.0\text{ V}$
Linearity error*	—	—	- 3.5	—	3.5	LSB	
Differential linearity error* <sup>1</sup>	—	—	- 3	—	3	LSB	
Zero transition voltage* <sup>1</sup>	$V_{OT}$	AN0 to AN11	$AV_{SS} - 3.5$	$AV_{SS} + 0.5$	$AV_{SS} + 4.5$	LSB	
Full transition voltage* <sup>1</sup>	$V_{FST}$	AN0 to AN11	$AVRH - 5.5$	$AVRH - 1.5$	$AVRH + 2.5$	LSB	
Conversion time	—	—	1.2* <sup>2</sup>	—	—	$\mu\text{S}$	
Analog port Input current	$I_{AIN}$	AN0 to AN11	—	—	10	$\mu\text{A}$	
Analog input voltage	$V_{AIN}$	AN0 to AN11	$AV_{SS}$	—	$AVRH$	V	
Reference voltage	—	$AVRHn$	$AV_{SS}$	—	$AV_{CC}$	V	
Analog power supply current (analog + digital)	$I_A$	$AV_{CC}$	—	2	—	mA	Per 1 unit
	$I_{AH}^{*3}$		—	—	100	$\mu\text{A}$	Per 1 unit
reference power supply current (between $AVRH$ and $AV_{SS}$ )	$I_R$	$AVRHn$	—	1	—	mA	Per 1 unit $AVRHn^{*4} = 5.0\text{ V}$ , at $AV_{SS} = 0\text{ V}$
	$I_{RH}^{*3}$		—	—	100	$\mu\text{A}$	per 1 unit at STOP
Analog input capacitance	—	—	—	10	—	pF	
Inter-channel disparity	—	AN0 to AN11	—	—	4	LSB	

\*1 : Measured in the CPU sleep state

\*2 :  $V_{CC} = AV_{CC} = 5.0\text{ V}$ , machine clock at 33 MHz

\*3 : The current when the CPU is in stop mode and the A/D converter is not operating (at  $V_{CC} = AV_{CC} = AVRHn = 5.0\text{ V}$ )

\*4 :  $AVRHn = AVRH0, AVRH1, AVRH2$

Note : The above does not guarantee the inter-unit accuracy.  
Set the output impedance of the external circuit  $\leq 2\text{ k}\Omega$ .

## Definition of A/D Converter Terms

- Resolution : Analog variation that is recognized by an A/D converter.
- Linearity error : Zero transition point (00 0000 0000  $\leftrightarrow$  00 0000 0001) and full-scale transition point. Difference between the line connected (11 1111 1110  $\leftrightarrow$  11 1111 1111) and actual conversion characteristics.
- Differential linearity error : Deviation of input voltage, that is required for changing output code by 1 LSB, from an ideal value.
- Total error : This error indicates the difference between actual and ideal values, including the zero transition error/full-scale transition error/linearity error.

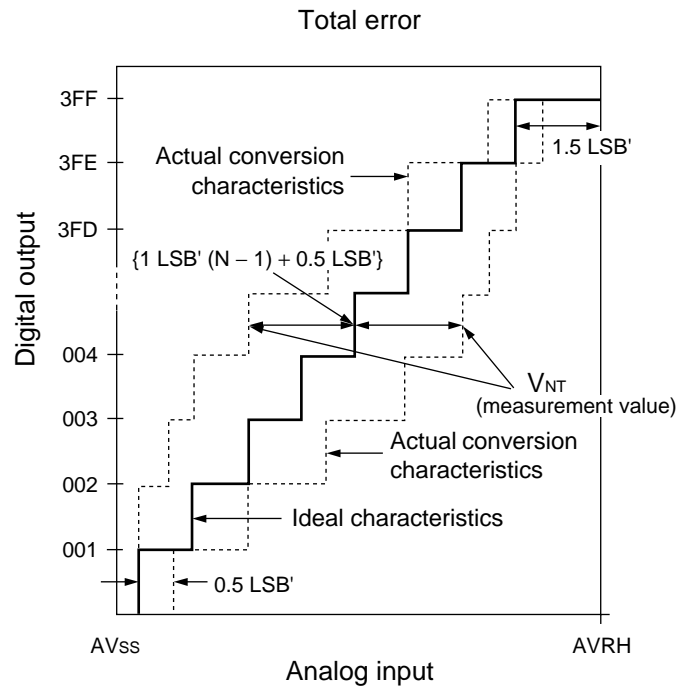

$$1\text{LSB}' \text{ (Ideal value)} = \frac{\text{AVRH} - \text{AVSS}}{1024} \text{ [V]} \quad \text{Total error of digital output N} = \frac{\text{V}_{\text{NT}} - \{1 \text{LSB}' \times (\text{N} - 1) + 0.5 \text{LSB}'\}}{1 \text{LSB}'}$$

$$\text{V}_{\text{OT}}' \text{ (Ideal value)} = \text{AVSS} + 0.5 \text{LSB}' \text{ [V]}$$

$$\text{V}_{\text{FST}}' \text{ (Ideal value)} = \text{AVRH} - 1.5 \text{LSB}' \text{ [V]} \quad \text{V}_{\text{NT}} : \text{A voltage at which digital output transitions from (N + 1) to N.}$$

(Continued)

# MB91260B Series

(Continued)

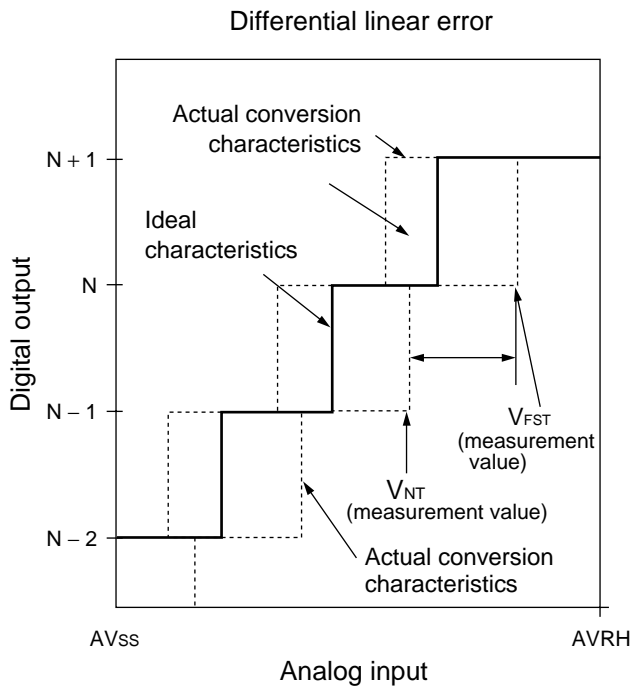
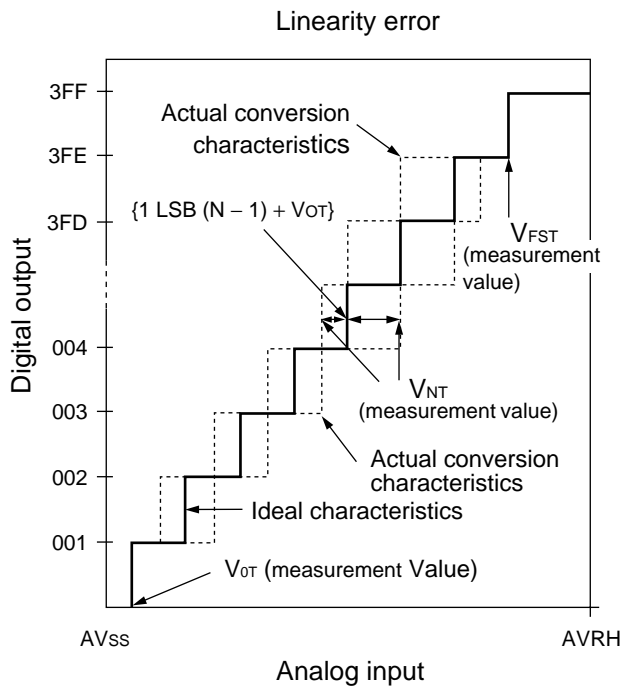

$$\text{Linearity error in digital output } N = \frac{V_{NT} - \{ 1 \text{ LSB} \times (N - 1) + V_{OT} \}}{1 \text{ LSB}} \text{ [LSB]}$$

$$\text{Differential linearity error in digital output } N = \frac{V_{(N+1)T} - V_{NT}}{1 \text{ LSB}} - 1 \text{ [LSB]}$$

$$1 \text{ LSB} = \frac{V_{FST} - V_{OT}}{1022} \text{ [V]}$$

$V_{OT}$  : A voltage at which digital output transitions from 000<sub>H</sub> to 001<sub>H</sub>.

$V_{FST}$  : A voltage at which digital output transitions from 3FE<sub>H</sub> to 3FF<sub>H</sub>.

## EXAMPLE CHARACTERISTICS

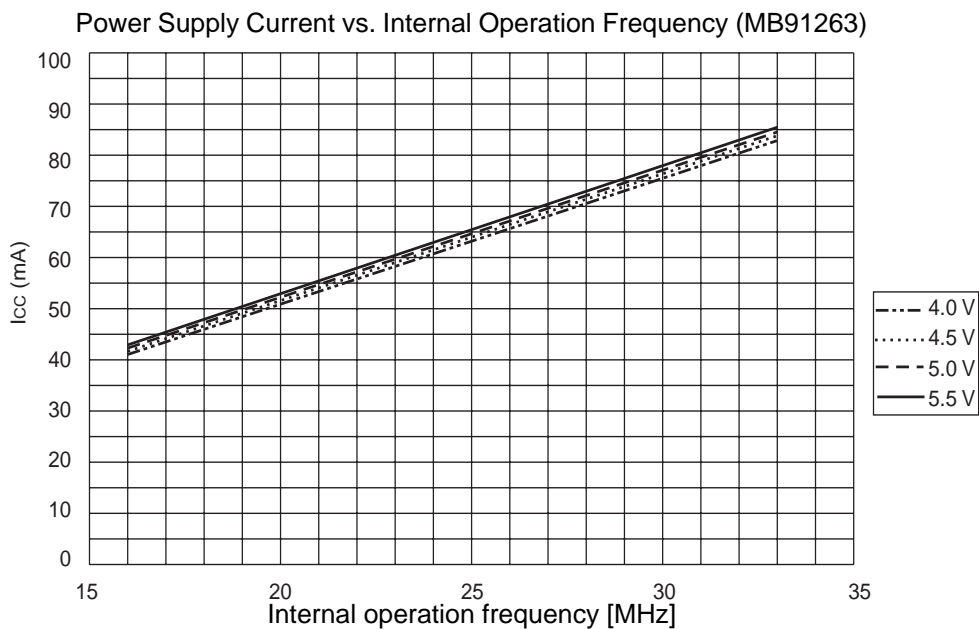
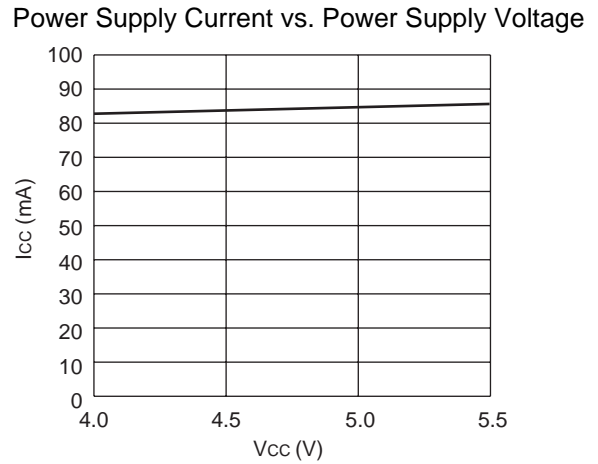
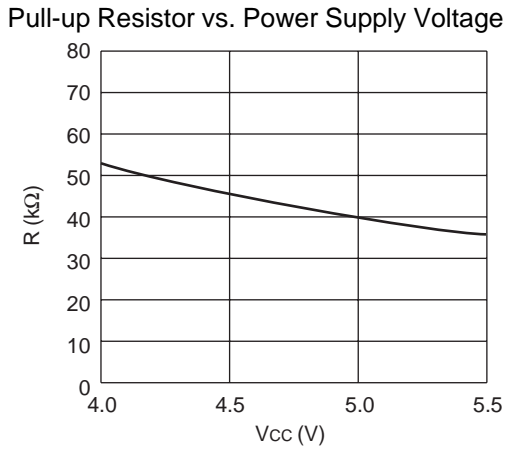
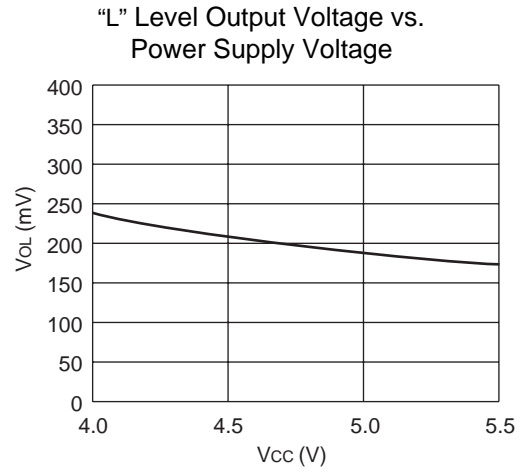
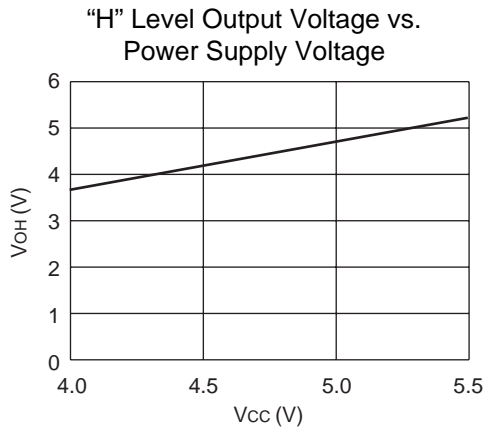

(Continued)

# MB91260B Series

(Continued)

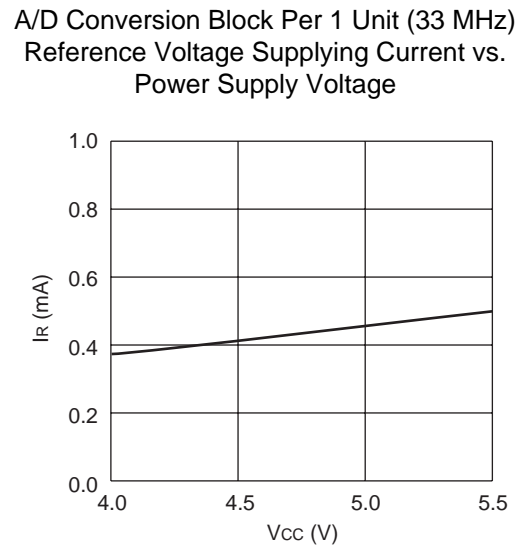
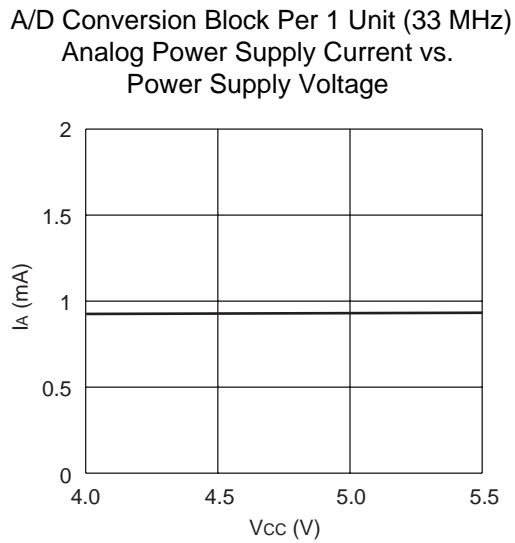
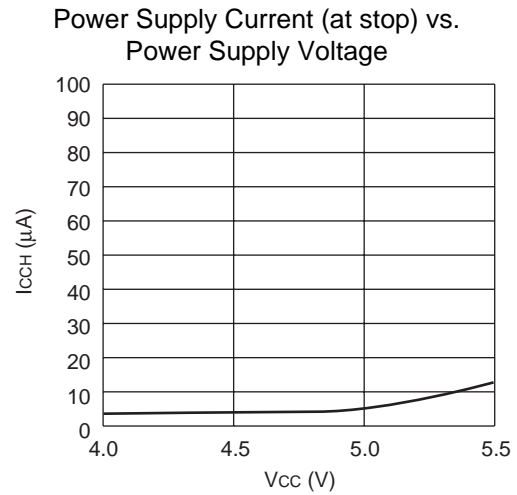
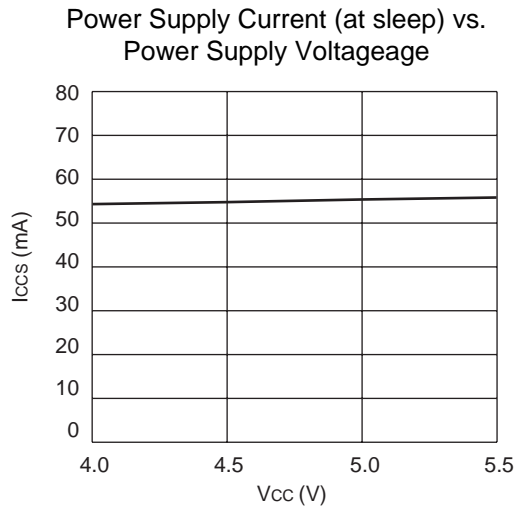



# MB91260B Series

## ■ ORDERING INFORMATION

Part number	Package	Remarks
MB91F264BPF-G	100-pin plastic QFP (FPT-100P-M06)	
MB91F264BPF-G-E1		Lead-free Package
MB91F264BPFV-G	100-pin plastic LQFP (FPT-100P-M05)	
MB91F264BPFV-G-E1		Lead-free Package
MB91263BPF-G-xxx-BND	100-pin plastic QFP (FPT-100P-M06)	
MB91263BPF-G-xxx-BNDE1		Lead-free Package
MB91263BPFV-G-xxx-BND	100-pin plastic LQFP (FPT-100P-M05)	
MB91263BPFV-G-xxx-BNDE1		Lead-free Package

# MB91260B Series

## PACKAGE DIMENSION

100 - pin plastic QFP  
(FPT-100P-M06)

Note 1) \* : These dimensions do not include resin protrusion.  
 Note 2) Pins width and pins thickness include plating thickness.  
 Note 3) Pins width do not include tie bar cutting remainder.

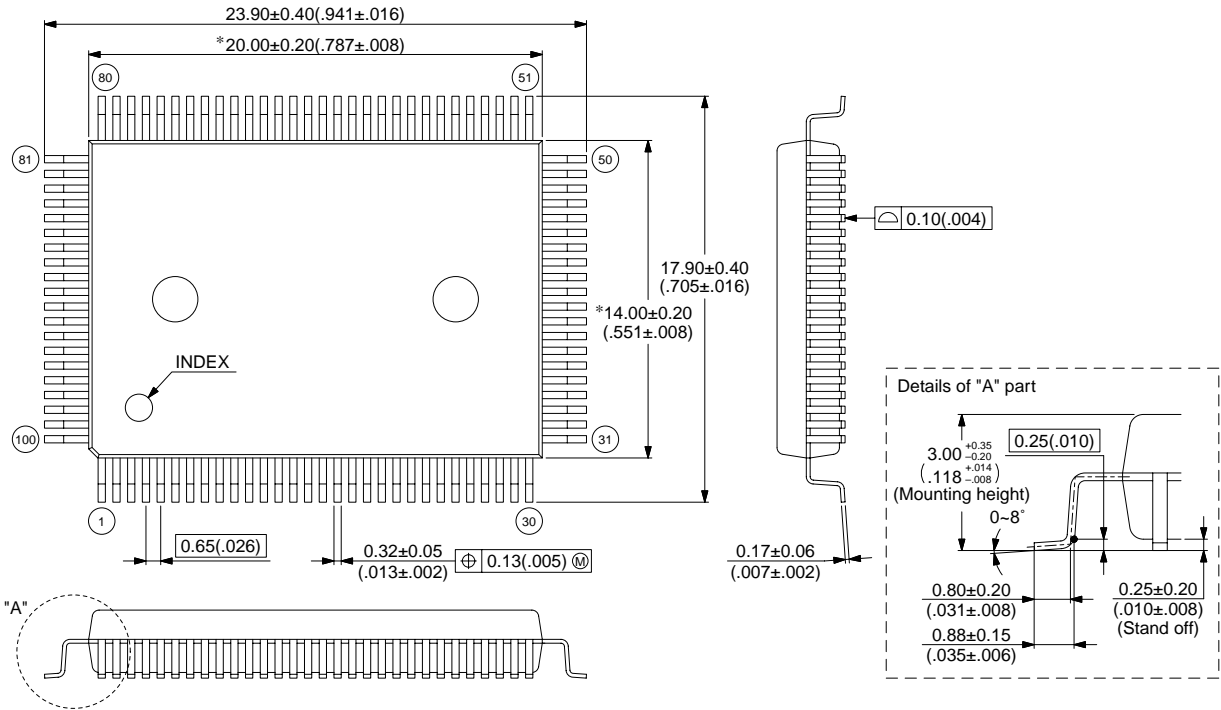

© 2002 FUJITSU LIMITED F100008S-c-5-5

Dimensions in mm (inches)

Note: The values in parentheses are reference values.

(Continued)

# MB91260B Series

(Continued)

100-pin plastic LQFP  
(FPT-100P-M05)

- Note 1) \* : These dimensions do not include resin protrusion.
- Note 2) Pins width and pins thickness include plating thickness.
- Note 3) Pins width do not include tie bar cutting remainder.

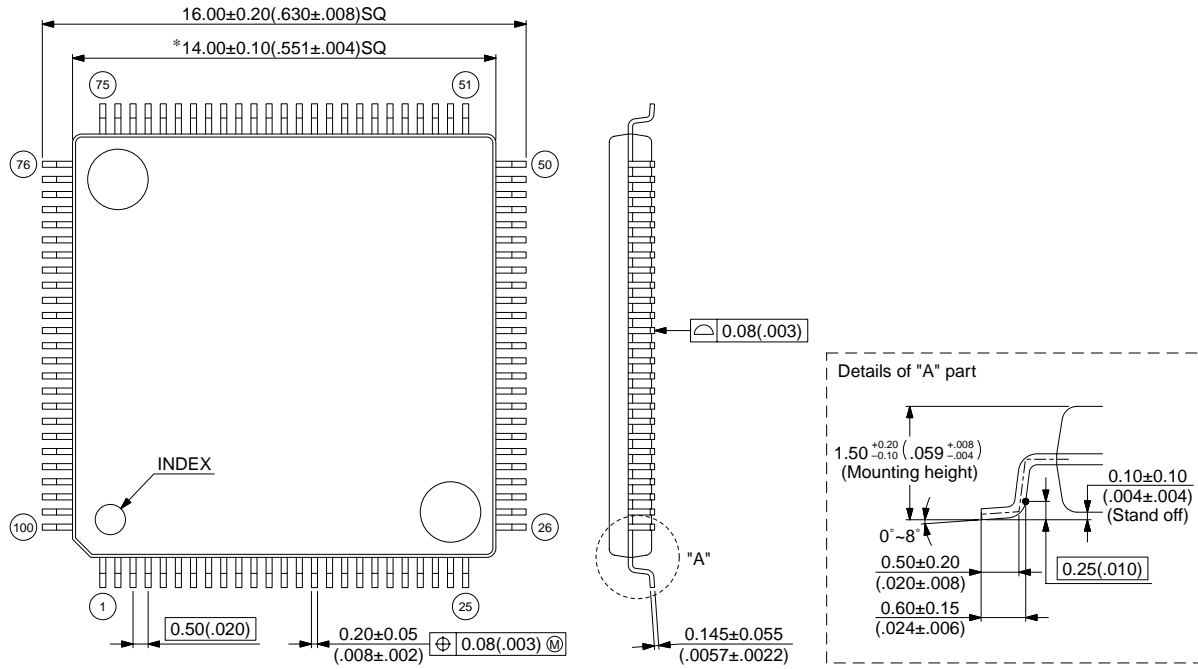

© 2003 FUJITSU LIMITED F100007S-c-4-6

Dimensions in mm (inches)

Note: The values in parentheses are reference values.

## FUJITSU LIMITED

All Rights Reserved.

The contents of this document are subject to change without notice. Customers are advised to consult with FUJITSU sales representatives before ordering.

The information, such as descriptions of function and application circuit examples, in this document are presented solely for the purpose of reference to show examples of operations and uses of Fujitsu semiconductor device; Fujitsu does not warrant proper operation of the device with respect to use based on such information. When you develop equipment incorporating the device based on such information, you must assume any responsibility arising out of such use of the information. Fujitsu assumes no liability for any damages whatsoever arising out of the use of the information.

Any information in this document, including descriptions of function and schematic diagrams, shall not be construed as license of the use or exercise of any intellectual property right, such as patent right or copyright, or any other right of Fujitsu or any third party or does Fujitsu warrant non-infringement of any third-party's intellectual property right or other right by using such information. Fujitsu assumes no liability for any infringement of the intellectual property rights or other rights of third parties which would result from the use of information contained herein.

The products described in this document are designed, developed and manufactured as contemplated for general use, including without limitation, ordinary industrial use, general office use, personal use, and household use, but are not designed, developed and manufactured as contemplated (1) for use accompanying fatal risks or dangers that, unless extremely high safety is secured, could have a serious effect to the public, and could lead directly to death, personal injury, severe physical damage or other loss (i.e., nuclear reaction control in nuclear facility, aircraft flight control, air traffic control, mass transport control, medical life support system, missile launch control in weapon system), or (2) for use requiring extremely high reliability (i.e., submersible repeater and artificial satellite).

Please note that Fujitsu will not be liable against you and/or any third party for any claims or damages arising in connection with above-mentioned uses of the products.

Any semiconductor devices have an inherent chance of failure. You must protect against injury, damage or loss from such failures by incorporating safety design measures into your facility and equipment such as redundancy, fire protection, and prevention of over-current levels and other abnormal operating conditions.

If any products described in this document represent goods or technologies subject to certain restrictions on export under the Foreign Exchange and Foreign Trade Law of Japan, the prior authorization by Japanese government will be required for export of those products from Japan.