

General Description

The MIC2562A PCMCIA (Personal Computer Memory Card International Association) and CardBus Power Controller handles all PC Card slot power supply pins, both V_{CC} and V_{PP} . The MIC2562A switches between the three V_{CC} voltages (0V, 3.3V and 5.0V) and the V_{PP} voltages (OFF, 0V, 3.3V, 5V, or 12.0V) required by PC Cards. The MIC2562A switches voltages from the system power supply to V_{CC} and V_{PP} . Output voltage is selected by two digital inputs each and output current ranges up to 1A for V_{CC} and 250mA for V_{PP} .

The MIC2562A provides power management capability controlled by the PC Card logic controller. Voltage rise and fall times are well controlled. Medium current V_{PP} and high current V_{CC} output switches are self-biasing: **no +12V supply is required for 3.3V or 5V output.**

The MIC2562A is designed for efficient operation. In standby (sleep) mode the device draws very little quiescent current, typically 0.3µA. The device and PCMCIA port is protected by current limiting and overtemperature shutdown. Full cross-conduction lockout protects the system power supply.

The MIC2562A is an improved version of the MIC2562, offering lower ON-resistance and a V_{CC} pull-down clamp in the OFF mode. It is available in a 14-pin 0.150" SOIC.

Ordering Information

Part Number	Temperature Range	Package
MIC2562A-0BM	-40°C to +85°C	14-pin Narrow SOIC
MIC2562A-1BM	-40°C to +85°C	14-pin Narrow SOIC

Note: see the logic table inside for a description of the differences between the logic options

Typical Application

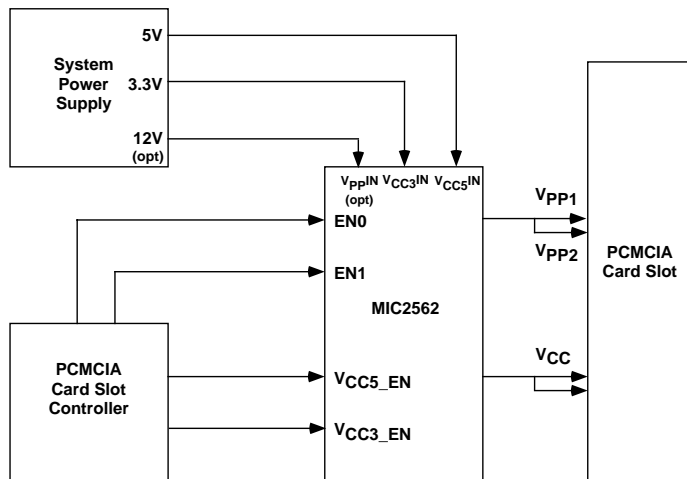

Applications

- PC Card Power Supply Pin Voltage Switch
- CardBus Slot Power Supply Control
- Data Collection Systems
- Machine Control Data Input Systems
- Wireless Communications
- Bar Code Data Collection Systems
- Instrumentation Configuration/Datalogging
- Docking Stations (portable and desktop)
- Power Supply Management
- Analog Power Switching

Features

- High Efficiency, Low Resistance Switches Require No 12V Bias Supply
- No External Components Required
- Output Current Limit and Overtemperature Shutdown
- Open-Drain Flag for Error Condition Indication
- Ultra Low Power Consumption
- Complete PC Card/CardBus V_{CC} and V_{PP} Switch Matrix in a Single Package
- Logic Compatible with Industry Standard PC Card Logic Controllers
- No Voltage Shoot-Through or Switching Transients
- Break-Before-Make Switching
- Digital Selection of V_{CC} and V_{PP} Voltages
- Over 1A V_{CC} Output Current
- Over 200mA V_{PP} Output Current
- Small 14-Pin SOIC Package

Pin Configuration

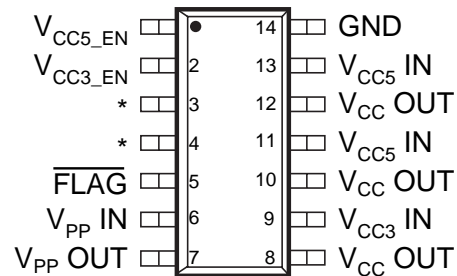

* see table below

14 Pin S.O. Package

Both V_{CC5} IN pins must be connected.
All three V_{CC} OUT pins must be connected.

MIC2562A Pin Assignments		
Pin	-0	-1
3	EN0	V_{PP_VCC}
4	EN1	V_{PP_PGM}

Absolute Maximum Ratings (Notes 1 and 2)

Power Dissipation, $T_{AMBIENT} \leq 25^{\circ}C$	<i>Internally Limited</i>
SOIC	800 mW
Derating Factors (To Ambient)	
SOIC	4 mW/ $^{\circ}C$
Storage Temperature	$-65^{\circ}C$ to $+150^{\circ}C$
Operating Temperature (Die)	$125^{\circ}C$
Lead Temperature (5 sec)	$260^{\circ}C$

Supply Voltage, $V_{PP IN}$	15V
$V_{CC3 IN}$	7.5V
$V_{CC5 IN}$	7.5V
FLAG Pull-up Voltage	7.5V
Logic Input Voltages	$-0.3V$ to $+10V$
Output Current (each Output)	
$V_{PP OUT}$	$>200mA$, <i>Internally Limited</i>
$V_{CC OUT}$	$>1A$, <i>Internally Limited</i>

Logic Block Diagram

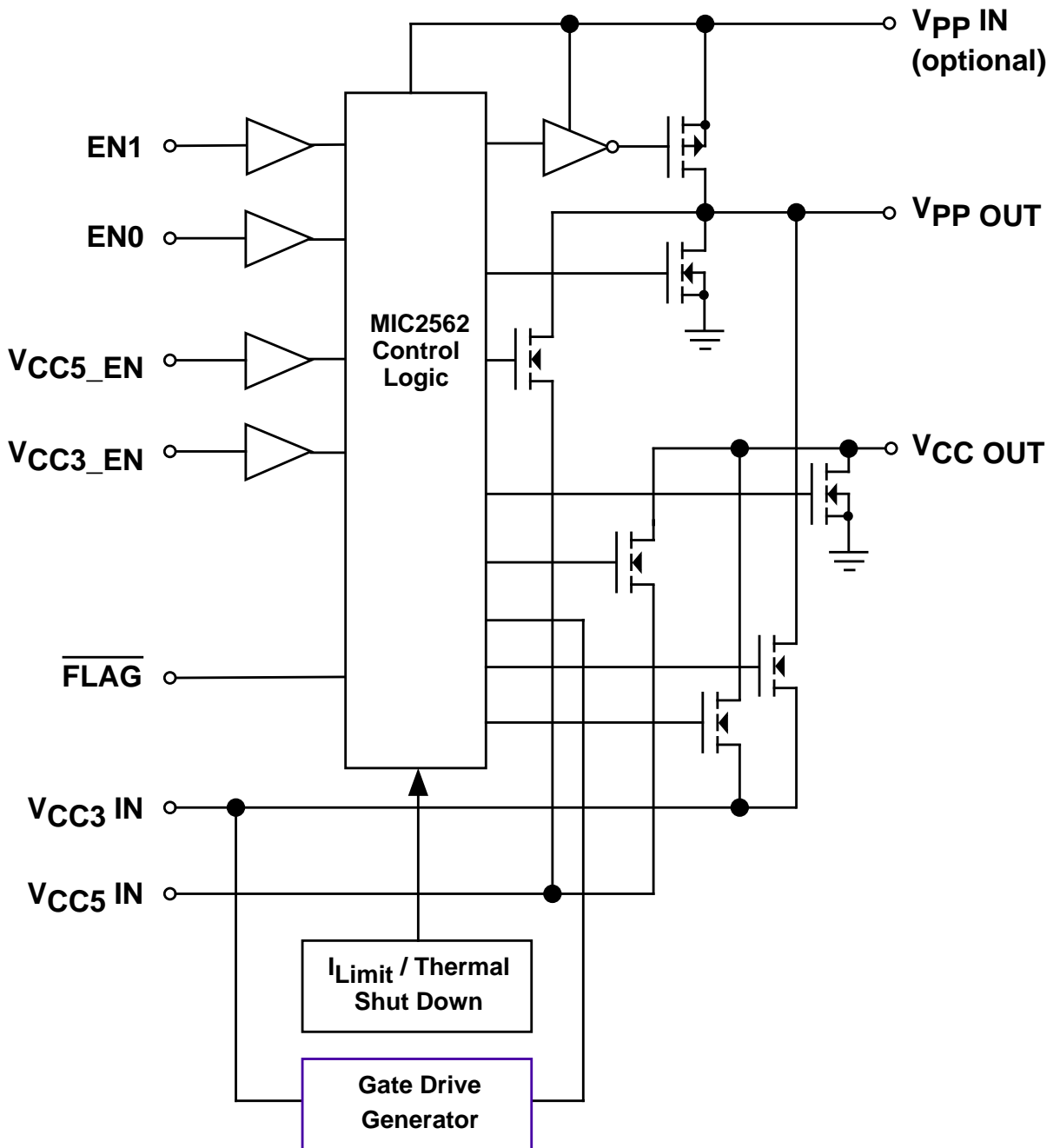

Electrical Characteristics: (Over operating temperature range with $V_{CC3\ IN} = 3.3V$, $V_{CC5\ IN} = 5.0V$, $V_{PP\ IN} = 12V$, unless otherwise specified.)

Symbol	Parameter	Conditions	Min	Typ	Max	Units
DIGITAL INPUTS						
V_{IH}	Logic 1 Input Voltage		2.2		7.5	V
V_{IL}	Logic 0 Input Voltage		-0.3		0.8	V
I_{IN}	Input Current	$0\ V < V_{IN} < 5.5V$			± 1	μA

 V_{PP} OUTPUT

$I_{PP\ OUT\ Hi-Z}$	High Impedance Output Leakage Current	Shutdown Mode $0 \leq V_{PP\ OUT} \leq 12V$		1	10	μA
I_{PPSC}	Short Circuit Current Limit	$V_{PP\ OUT} = 0$	0.2	0.4		A
R_O	Switch Resistance,	Select $V_{PP\ OUT} = 5V$ Select $V_{PP\ OUT} = 3.3V$ $I_{PP\ OUT} = -100mA$ (Sourcing)		1.8 3.3	2.5 5	Ω
R_O	Switch Resistance, Select $V_{PP\ OUT} = 12V$	$V_{PP\ IN} = 12V$ $I_{PP\ OUT} = -100\ mA$ (Sourcing)		0.6	1	Ω
R_O	Switch Resistance, Select $V_{PP\ OUT} = 0V$	Select $V_{PP\ OUT} =$ clamped to ground $I_{PP\ OUT} = 50\mu A$ (Sinking)		2500	3900	Ω

 V_{PP} SWITCHING TIME (See Figure 1)

t_1 t_2 t_3	Output Turn-ON Delay (Note 3)	$V_{PP\ OUT} =$ Hi-Z to 10% of 3.3V $V_{PP\ OUT} =$ Hi-Z to 10% of 5V $V_{PP\ OUT} =$ Hi-Z to 10% of 12V		5 10 70	50 50 250	μs
t_4 t_5 t_6	Output Rise Time (Note 3)	$V_{PP\ OUT} =$ 10% to 90% of 3.3V $V_{PP\ OUT} =$ 10% to 90% of 5V $V_{PP\ OUT} =$ 10% to 90% of 12V	100 100 100	200 300 225	800 1000 800	μs
t_7 t_8 t_9 t_{10}	Output Transition Timing (Note 3)	$V_{PP\ OUT} =$ 3.3V to 90% of 12V $V_{PP\ OUT} =$ 5V to 90% of 12V $V_{PP\ OUT} =$ 12V to 90% of 3.3V $V_{PP\ OUT} =$ 12V to 90% of 5V	100 100 100 100	250 200 200 350	1000 800 800 1200	μs
t_{14} t_{15} t_{16}	Output Turn-Off Delay Time (Note 3)	$V_{PP\ OUT} =$ 3.3V to Hi-Z $V_{PP\ OUT} =$ 5V to Hi-Z $V_{PP\ OUT} =$ 12V to Hi-Z		200 200 200	1000 1000 1000	ns
t_{11} t_{12} t_{13}	Output Turn-OFF Fall Time (Note 3)	$V_{PP\ OUT} =$ 90% to 10% of 3.3V $V_{PP\ OUT} =$ 90% to 10% of 5V $V_{PP\ OUT} =$ 90% to 10% of 12V		50 50 300	1000 1000 2000	ns

Electrical Characteristics (continued)

Symbol	Parameter	Conditions	Min	Typ	Max	Units
V_{CC} OUTPUT						
I _{CCSC}	Short Circuit Current Limit	V _{CC OUT} = 0	1	1.5		A
R _O	Switch Resistance	Select V _{CC OUT} = 3.3V I _{CC OUT} = -1A (Sourcing)		100	150	mΩ
		Select V _{CC OUT} = 5V I _{CC OUT} = -1A (Sourcing)		70	100	mΩ
		Select V _{CC OUT} = clamped to ground I _{CC OUT} = 0.1mA (Sinking)		500	3900	Ω
V_{CC} SWITCHING TIME (See Figure 2)						
t ₁	Output Turn ON Delay Time	V _{CC OUT} = 0V to 10% of 3.3V		300	1500	μs
t ₂	(Note 4)	V _{CC OUT} = 0V to 10% of 5.0V		750	3000	
t ₃	Output Rise Time (Note 4)	V _{CC OUT} = 10% to 90% of 3.3V	200	700	2500	μs
t ₄		V _{CC OUT} = 10% to 90% of 5V	200	1500	6000	
t ₇	Output Turn-Off Delay (Notes 4, 5)	V _{CC OUT} = 3.3V		2.4	8	ms
t ₈		V _{CC OUT} = 5V		2.8	8	
t ₅	Output Fall Time (Note 4)	V _{CC OUT} = 90% to 10% of 3.3V	100	240	1000	μs
t ₆		V _{CC OUT} = 90% to 10% of 5.0V	100	600	2000	
POWER SUPPLY						
I _{CC5}	V _{CC5 IN} Supply Current (5V)	V _{CC OUT} = 5V or 3.3V, I _{CC OUT} = 0 V _{CC OUT} = 0V (Sleep Mode)		8 0.2	50 10	μA
I _{CC3}	V _{CC3 IN} Supply Current (3.3V) (Note 6)	V _{CC OUT} = 5V or 3.3V, I _{CC OUT} = 0 V _{CC OUT} = 0V (Sleep Mode)		40 0.1	100 10	μA
I _{PP IN}	V _{PP IN} Supply Current (12V) (Note 7)	V _{PP OUT} = 3.3V or 5V. I _{PP OUT} = 0 V _{PP OUT} = Hi-Z, 0 or V _{PP}		0.3 0.3	4 4	μA
V _{CC5}	Operating Input Voltage (5V)	V _{CC5 IN} not required for operation	—	5.0	6	V
V _{CC3}	Operating Input Voltage (3.3V)	(Note 6)	3.0	3.3	6	V
V _{PP IN}	Operating Input Voltage (12V)	V _{PP IN} not required for operation (Note 8)	—	12.0	14.5	V

Electrical Characteristics (continued)

Symbol	Parameter	Conditions	Min	Typ	Max	Units
THERMAL SHUTDOWN						
T _{SD}	Thermal Shutdown Temperature			130		°C
FLAG OUTPUT						
V _O OK	FLAG Threshold Voltage (Note 9)	FLAG High (OK) Threshold voltage		V _{CC} - 1 V _{PP} - 1		V

- NOTE 1:** Functional operation above the absolute maximum stress ratings is not implied.
- NOTE 2:** Static-sensitive device. Store only in conductive containers. Handling personnel and equipment should be grounded to prevent damage from static discharge.
- NOTE 3:** R_L = 100Ω connected to ground.
- NOTE 4:** R_L = 10Ω connected to ground.
- NOTE 5:** Delay from commanding Hi Z or 0V to beginning slope. Does not apply to current limit or overtemperature shutdown conditions.
- NOTE 6:** The MIC2562A uses V_{CC3 IN} for operation. For single 5V supply systems, connect 5V to both V_{CC3 IN} and V_{CC5IN}. See Applications Information for further details.
- NOTE 7:** V_{PP IN} is not required for operation.
- NOTE 8:** V_{PP IN} must be either high impedance or greater than or approximately equal to the highest voltage V_{CC} in the system. For example, if both 3.3V and 5V are connected to the MIC2562A, V_{PP IN} must be either 5V, 12V, or high impedance.
- NOTE 9:** A 10kΩ pull-up resistor is connected between FLAG and V_{CC3 IN}.

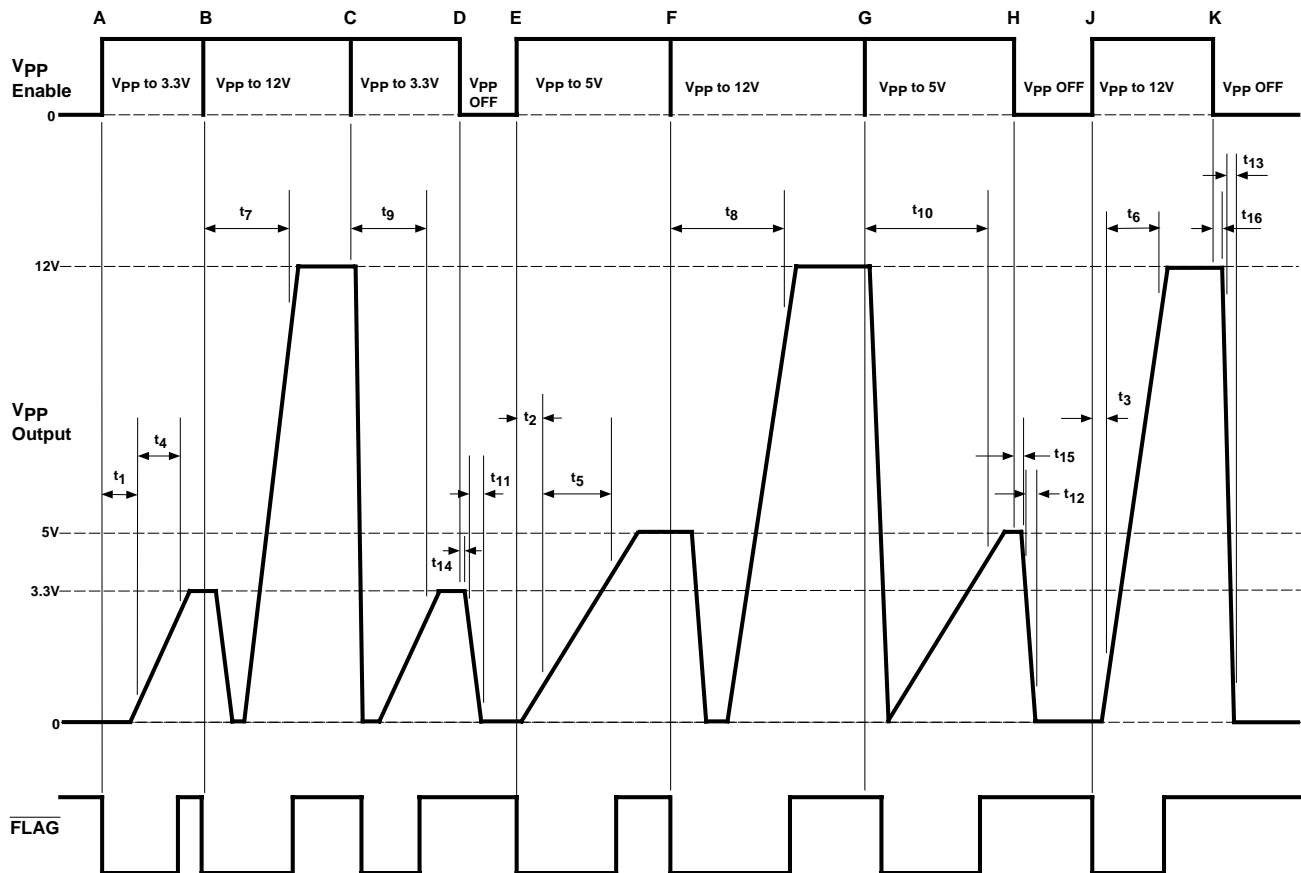

Figure 1. MIC2562A V_{PP} Timing Diagram. V_{PP} Enable is shown generically: refer to the timing tables (below). At time “A” V_{PP} = 3.3V is selected. At B, V_{PP} is set to 12V. At C, V_{PP} = 3.3V (from 12V). At D, V_{PP} is disabled. At E, V_{PP} is programmed to 5V. At F, V_{PP} is set to 12V. At G, V_{PP} is programmed to 5V. At H, V_{PP} is disabled. At J, V_{PP} is set to 12V. And at K, V_{PP} is again disabled. R_L = 100Ω for all measurements. Load capacitance is negligible.

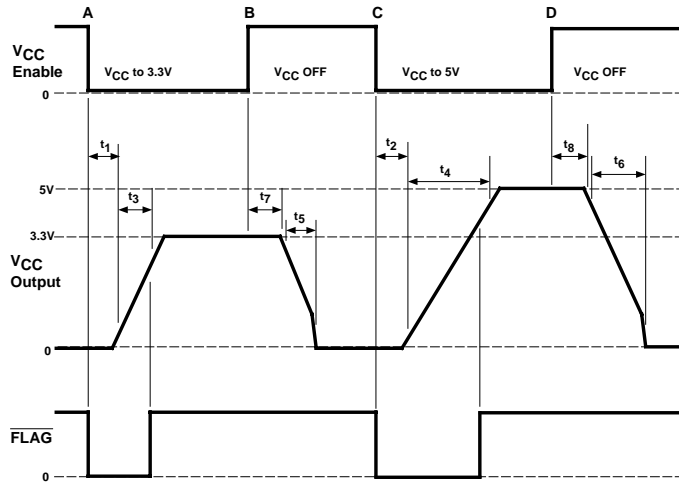

Figure 2. MIC2562A V_{CC} Timing Diagram. V_{CC} Enable is shown generically: refer to the timing tables (below) for specific control logic input. At time A, V_{CC} is programmed to 3.3V. At B, V_{CC} is disabled. At C, V_{CC} is programmed to 5V. And at D, V_{CC} is disabled. R_L = 10Ω. FLAG pull-up resistor is 10kΩ to V_{CC3} IN.

MIC2562A-0 Control Logic Table

V _{CC5_EN}	V _{CC3_EN}	EN1	EN0	V _{CC} OUT	V _{PP} OUT
0	0	0	0	Clamped to Ground	High Z
0	0	0	1	Clamped to Ground	High Z
0	0	1	0	Clamped to Ground	High Z
0	0	1	1	Clamped to Ground	Clamped to Ground
0	1	0	0	3.3	High Z
0	1	0	1	3.3	3.3
0	1	1	0	3.3	12
0	1	1	1	3.3	Clamped to Ground
1	0	0	0	5	High Z
1	0	0	1	5	5
1	0	1	0	5	12
1	0	1	1	5	Clamped to Ground
1	1	0	0	3.3	High Z
1	1	0	1	3.3	3.3
1	1	1	0	3.3	5
1	1	1	1	3.3	Clamped to Ground

MIC2562A-1 Control Logic (compatible with Cirrus Logic CL-PD6710 & PD672x-series Controllers)

V _{CC5_EN}	V _{CC3_EN}	V _{PP_PGM}	V _{PP_VCC}	V _{CC} OUT	V _{PP} OUT
0	0	0	0	Clamped to Ground	Clamped to Ground
0	0	0	1	Clamped to Ground	High Z
0	0	1	0	Clamped to Ground	High Z
0	0	1	1	Clamped to Ground	High Z
0	1	0	0	5	Clamped to Ground
0	1	0	1	5	5
0	1	1	0	5	12
0	1	1	1	5	High Z
1	0	0	0	3.3	Clamped to Ground
1	0	0	1	3.3	3.3
1	0	1	0	3.3	12
1	0	1	1	3.3	High Z
1	1	0	0	Clamped to Ground	Clamped to Ground
1	1	0	1	Clamped to Ground	High Z
1	1	1	0	Clamped to Ground	High Z
1	1	1	1	Clamped to Ground	High Z

Applications Information

PC Card V_{CC} and V_{PP} control is easily accomplished using the MIC2562A PC Card/CardBus Slot V_{CC} & V_{PP} Power Controller IC. Four control bits determine $V_{CC\ OUT}$ and $V_{PP\ OUT}$ voltage and standby/operate mode condition. V_{CC} outputs of 3.3V and 5V at the maximum allowable PC Card current are supported. $V_{PP\ OUT}$ output voltages of V_{CC} (3.3V or 5V), V_{PP} , 0V, or a high impedance state are available. When the V_{CC} clamped to ground condition is selected, the device switches into "sleep" mode and draws only nano-amperes of leakage current. An error flag alerts the user if the output voltage is too low because of overtemperature or overcurrent faults. Protection from hot switching is provided which prevents feedback from the $V_{CC\ OUT}$ (from 5V to 3.3V, for example) by locking out the low voltage switch until the initial switch's gate voltage drops below the desired lower V_{CC} .

The MIC2562A operates from the computer system main power supply. Device logic and internal MOSFET drive is generated internally by charge pump voltage multipliers powered from $V_{CC3\ IN}$. Switching speeds are carefully controlled to prevent damage to sensitive loads and meet all PC Card Specification speed requirements.

Supply Bypassing

External capacitors are not required for operation. The MIC2562A is a switch and has no stability problems. For best results however, bypass $V_{CC3\ IN}$, $V_{CC5\ IN}$, and $V_{PP\ IN}$ inputs with 1 μ F capacitors to improve output ripple. As all internal device logic and comparison functions are powered from the $V_{CC3\ IN}$ line, the power supply quality of this line is the most important, and a bypass capacitor may be necessary for some layouts. Both $V_{CC\ OUT}$ and $V_{PP\ OUT}$ pins may use 0.01 μ F to 0.1 μ F capacitors for noise reduction and electrostatic discharge (ESD) damage prevention. Larger values of output capacitors are not necessary.

PC Card Slot Implementation

The MIC2562A is designed for full compatibility with the Personal Computer Memory Card International Association's (PCMCIA) PC Card Specification, (March 1995), including the CardBus option. One MIC2562A is required for each PC Card slot.

When a memory card is initially inserted, it should receive V_{CC} — either $3.3V \pm 0.3V$ or $5.0V \pm 5\%$. The initial voltage is determined by a combination of mechanical socket "keys" and voltage sense pins. The card sends a handshaking data stream to the controller, which then determines whether or not this card requires V_{PP} and if the card is designed for dual V_{CC} . If the card is compatible with and desires a different V_{CC} level, the controller commands this change by disabling V_{CC} , waiting at least 100ms, and then re-enabling the other V_{CC} voltage.

V_{CC} switches are turned ON and OFF slowly. If commanded to immediately switch from one V_{CC} to the other (without turning OFF and waiting 100ms first), enhancement of the second switch begins after the first is OFF, realizing break-before-make protection. V_{PP} switches are turned ON slowly and OFF quickly, which also prevents cross conduction.

If no card is inserted or the system is in sleep mode, the slot logic controller outputs a ($V_{CC3\ IN}$, $V_{CC5\ IN}$) = (0,0) to the MIC2562A, which shuts down V_{CC} . This also places the switch into a high impedance output shutdown (sleep) mode, where current consumption drops to nearly zero, with only tiny CMOS leakage currents flowing.

Internal device control logic and MOSFET drive and bias voltage is powered from $V_{CC3\ IN}$. The high voltage bias is generated by an internal charge pump quadrupler. Systems without 3.3V may connect $V_{CC3\ IN}$ to 5V. Input logic threshold voltages are compatible with common PC Card logic controllers using either 3.3V or 5V supplies.

The PC Card Specification defines two V_{PP} supply pins per card slot. The two V_{PP} supply pins may be programmed to different voltages. V_{PP} is primarily used for programming FLASH memory cards. Implementing two independent V_{PP} voltages is easily accomplished with the MIC2562A and a MIC2557 PCMCIA V_{PP} Switching Matrix. Figure 3 shows this full configuration, supporting independent V_{PP} and both 5.0V and 3.3V V_{CC} operation. However, few logic controllers support multiple V_{PP} —most systems connect V_{PP1} to V_{PP2} and the MIC2557 is not required. This circuit is shown in Figure 4.

During Flash memory programming with standard (+12V) Flash memories, the PC Card slot logic controller outputs a (0,1) to the EN0, EN1 control pins of the MIC2562A, which connects $V_{PP\ IN}$ (nominally +12V) to $V_{PP\ OUT}$. The low ON resistance of the MIC2562A switch allows using a small bypass capacitor on the $V_{PP\ OUT}$ pins, with the main filtering action performed by a large filter capacitor on $V_{PP\ IN}$ (usually the main power supply filter capacitor is sufficient). Using a small-value capacitor such as 0.1 μ F on the output causes little or no timing delays. The $V_{PP\ OUT}$ transition from V_{CC} to 12.0V typically takes 250 μ s. After programming is completed, the controller outputs a (EN1, EN0) = (0,1) to the MIC2562A, which then reduces $V_{PP\ OUT}$ to the V_{CC} level. Break-before-make switching action and controlled rise times reduces switching transients and lowers maximum current spikes through the switch.

Figure 5 shows MIC2562A configuration for situations where only a single +5V V_{CC} is available.

Output Current and Protection

MIC2562A output switches are capable of passing the maximum current needed by any PC Card. The MIC2562A meets or exceeds all PCMCIA specifications. For system and card protection, output currents are internally limited. For full system protection, long term (millisecond or longer) output short circuits invoke overtemperature shutdown, protecting the MIC2562A, the system power supplies, the card socket pins, and the PC Card. A final protective feature is the error FLAG, which signals the PC Card slot logic controller when a fault condition exists, allowing the controller to notify the user that the card inserted has a problem. The open-drain FLAG monitors the voltage level on both $V_{CC\ OUT}$ and $V_{PP\ OUT}$ and activates (pulls low) when either output is 1V below its programmed level or an overtemperature fault exists.

This FLAG signals output voltage transitions as well as fault conditions. Refer to Figures 1 and 2 for details.

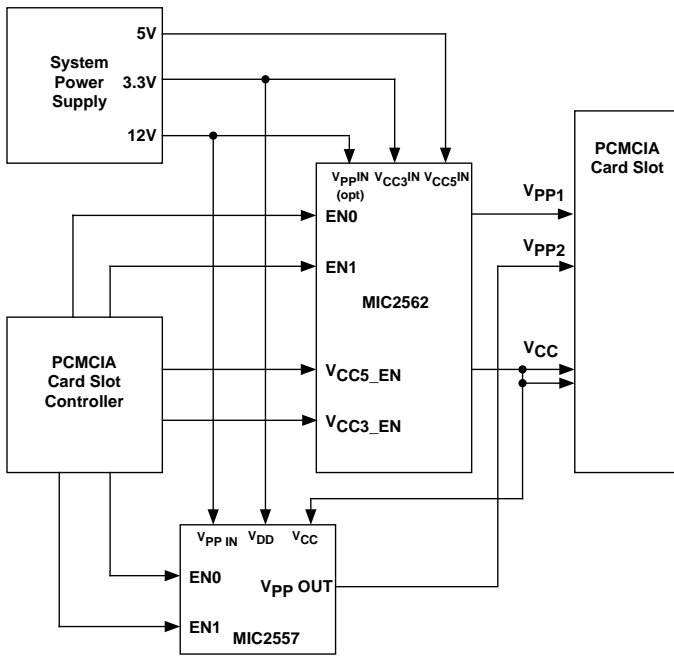

Figure 3. MIC2562A PC Card slot power control application with dual V_{CC} (5V and 3.3V) and separate V_{PP1} and V_{PP2} .

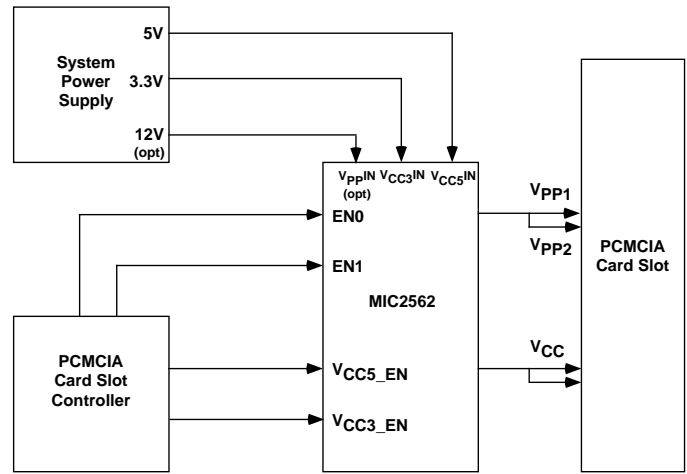

Figure 4. Typical MIC2562A PC Card slot power control application with dual V_{CC} (5V and 3.3V). Note that V_{PP1} and V_{PP2} are driven together.

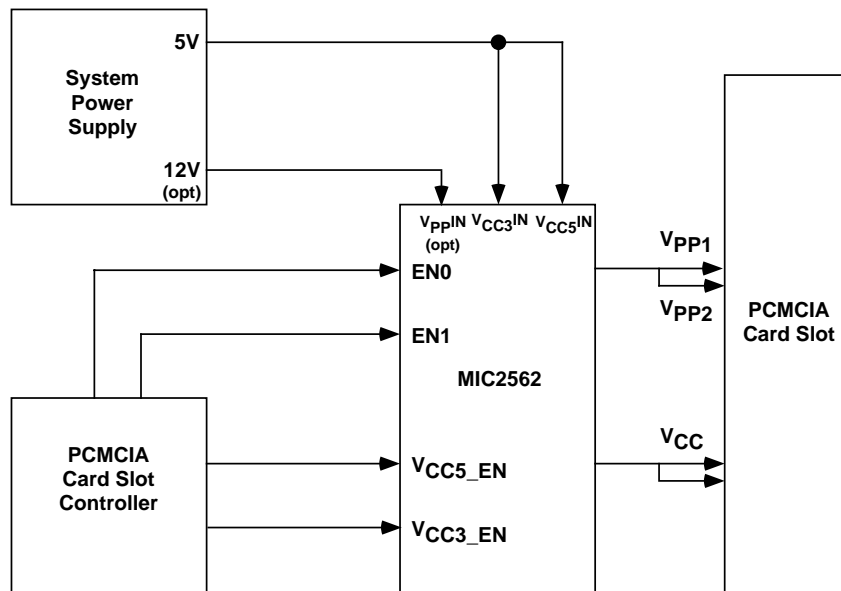

Figure 5. PC Card slot power control application without an available 3.3V V_{CC} . Note that V_{CC3IN} and V_{CC5IN} are driven together. The MIC2562A is powered by the V_{CC3IN} line. In this configuration, V_{CCOUT} will be 5V when either V_{CC3} or V_{CC5} is enabled from the logic table. Take advantage of the lower switch resistance of the V_{CC5} switch by using the V_{CC5_EN} control as your main V_{CC} switch.