

DUAL MONOSTABLE MULTIVIBRATOR

GENERAL DESCRIPTION

The MMC 4098 is a monolithic integrated circuit, available in 16-lead dual in-line plastic or ceramic package. The MMC 4098 dual monostable multivibrator provides stable retriggerable/resettable one-shot operation for any fixed-voltage timing application. An external resistor (R_x) and an external capacitor (C_x) control the timing for the circuit. Adjustment of R_x and C_x provides a wide range of output pulse widths from the Q and \bar{Q} terminals. The time delay from trigger input to output transition (trigger propagation delay) and the time delay from reset input to output transition (reset propagation delay) are independent of R_x and C_x .

Leading-edge-triggering (+TR) and trailing-edge-triggering (-TR) inputs are provided for triggering from either edge of an input pulse. An unused +TR input should be tied to V_{SS} . An unused -TR input should be tied to V_{DD} . A RESET (on low level) is provided for immediate termination of the output pulse or to prevent output pulses when power is turned on. An unused RESET input should be tied to V_{DD} . However, if an entire section of the MMC 4098 is not used, its RESET should be tied to V_{SS} . See Table I. In normal operation the circuit triggers (extends the output pulse one period) on the application of each new trigger pulse. For operation in the non-triggera-

ble mode, Q is connected to -TR when leading-edge triggering (+TR) is used or Q is connected to +TR when trailing-edge triggering (-TR) is used. The time period (T) for this multivibrator can be approximated

by: $T_x = \frac{1}{2} R_x C_x$ for $C_x \geq 0.01 \mu\text{F}$. Values of T

vary from unit to unit and as a function of voltage, temperature, and $R_x C_x$. The minimum value of external resistance, R_x , is 5 k Ω . The maximum value of external capacitance, C_x , is 100 μF . The output pulse width has variations of $\pm 2.5\%$ typically over the temperature range of -55°C to 125°C for $C_x = 1000 \text{ pF}$ and $R_x = 100 \text{ k}\Omega$.

For power supply variations of $\pm 5\%$, the output pulse width has variations of $\pm 0.5\%$ typically, for $V_{DD} = 10 \text{ V}$ and 15 V and $\pm 1\%$ typically, for $V_{DD} = 5 \text{ V}$ at $C_x = 1000 \text{ pF}$ and $R_x = 5 \text{ k}\Omega$.

FEATURES

- Retriggerable/resettable capability
- Trigger and reset propagation delays independent of R_x, C_x
- Triggering from leading or trailing edge
- Q and \bar{Q} buffered outputs available
- Separate resets
- Wide range of output-pulse widths

ABSOLUTE MAXIMUM RATINGS

V_{DD}^*	Supply voltage: G and H types	-0.5 to	20	V
	E and F types	-0.5 to	18	V
V_i	Input voltage	-0.5 to	$V_{DD} + 0.5$	V
I_i	DC input current (any one input)		± 10	mA
P_{tot}	Total power dissipation (per package)		200	mW
	Dissipation per output transistor for $T_A =$ full package-temperature range		100	mW
T_A	Operating temperature: G and H types	-55 to	125	$^\circ\text{C}$
	E and F types	-40 to	85	$^\circ\text{C}$
T_{stg}	Storage temperature	-65 to	150	$^\circ\text{C}$

* All voltage values are referred to V_{SS} pin voltage

RECOMMENDED OPERATING CONDITIONS

V_{DD}^*	Supply voltage: G and H types	3 to	18	V
	E and F types	3 to	15	V
V_i	Input voltage	0 to	V_{DD}	V
T_A	Operating temperature: G and H types	-55 to	125	$^\circ\text{C}$
	E and F types	-40 to	85	$^\circ\text{C}$

CONNECTION DIAGRAM

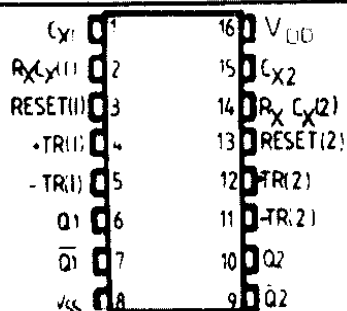

LOGIC DIAGRAM

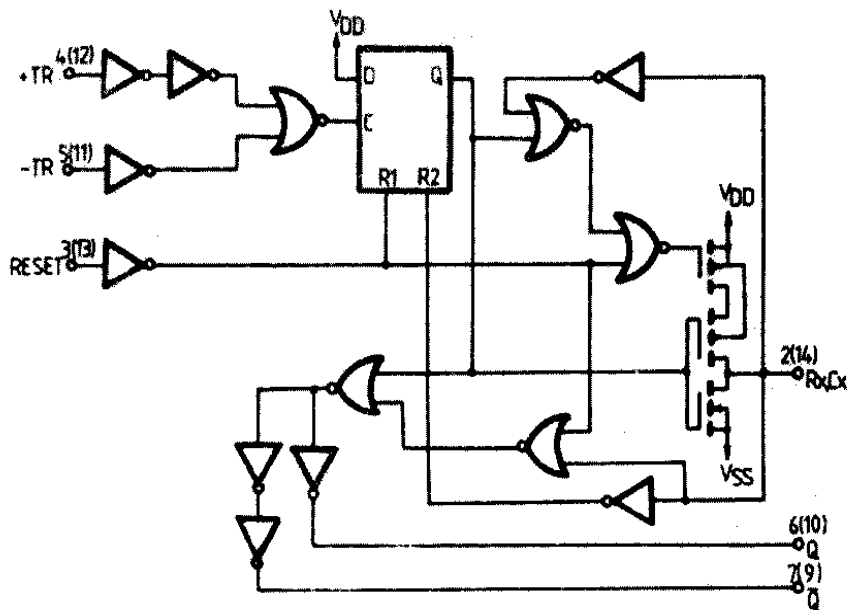

FUNCTIONAL DIAGRAM

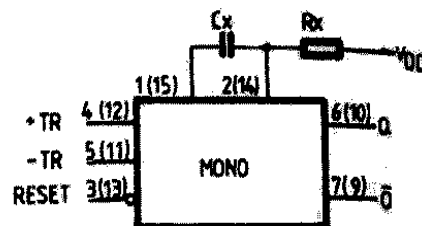
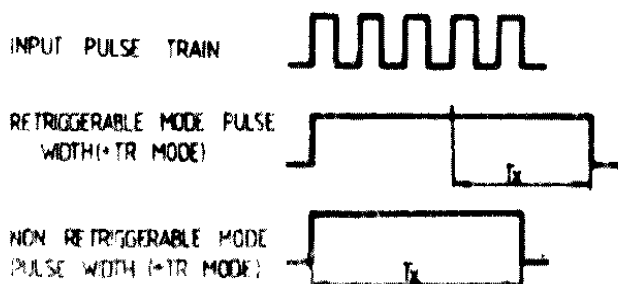

TABLE I

– Functional terminal connections

FUNCTION	TERMINAL CONNECTIONS						OTHER CON- NECTIONS	
	TO VDD		TO VSS		INPUT PULSE TO			
	Mono (1)	Mono (2)	Mono (1)	Mono (2)	Mono (1)	Mono (2)	Mono (1)	Mono (2)
Leading-Edge Trigger/Retriggerable	3,5	11,13			4	12		
Leading-Edge Trigger/Non-retriggerable	3	13			4	12	5,7	11,9
Trailing-Edge Trigger/Retriggerable	3	13	4	12	5	11		
Trailing-Edge Trigger/Non-retriggerable	3	13			5	11	4,6	12,10
Unused Section	5	11	3,4	12,13				

NOTES: 1) A Retriggerable one-shot multivibrator has an output pulse width which is extended one full time period (T_x) after application of the last trigger pulse.
 2) A Non-retriggerable one-shot multivibrator has a time period T_x referenced from the application of the first trigger pulse



STATIC ELECTRICAL CHARACTERISTICS

(over recommended operating conditions)

PARAMETER		TEST CONDITIONS				VALUES						UNIT	
		V _I (V)	V _O (V)	I _O (μ A)	V _{DD} (V)	T _{LOW}		25°C			T _{HIGH}		
						min.	max.	min.	typ	max.	min.		max.
I _L	Quiescent current	G, H types	0/ 5			5		1		0.02	1		30
			0/10			10		2		0.02	2		60
			0/15			15		4		0.02	4		120
			0/20			20		20		0.04	20		600
	E, F types	0/ 5			5		4		0.02	4		30	
		0/10			10		8		0.02	8		60	
		0/15			15		16		0.02	16		120	
V _{OH}	Output high voltage												
		0/ 5		< 1	5	4.95		4.95			4.95		
		0/10		< 1	10	9.95		9.95			9.95		
		0/15		< 1	15	14.95		14.95			14.95		
V _{OL}	Output low voltage												
		5 / 0		< 1	5		0.05			0.05		0.05	
		10/ 0		< 1	10		0.05			0.05		0.05	
		15/ 0		< 1	15		0.05			0.05		0.05	
V _{IH}	Input high voltage												
			0.5/4.5	< 1	5	3.5		3.5			3.5		
			1/9	< 1	10	7		7			7		
			1.5/13.5	< 1	15	11		11			11		
V _{IL}	Input low voltage												
			4.5/0.5	< 1	5		1.5			1.5		1.5	
			9/1	< 1	10		3			3		3	
			13.5/1.5	< 1	15		4			4		4	
I _{OH}	Output drive current	G, H types	0/ 5	2.5		5	-2		-1.6	-3.2		-1.15	
			0/ 5	4.6		5	-0.64		-0.51	-1		-0.36	
			0/10	9.5		10	-1.6		-1.3	-2.6		-0.9	
			0/15	13.5		15	-4.2		-3.4	-6.8		-2.4	
	E, F types	0/ 5	2.5		5	-1.53		-1.36	-3.2		-1.1		
		0/ 5	4.6		5	-0.52		-0.44	-1		-0.36		
		0/10	9.5		10	-1.3		-1.1	-2.6		-0.9		
		0/15	13.5		15	-3.6		-3.0	-6.8		-2.4		
I _{OL}	G, H types	0/ 5	0.4		5	0.64		0.51	1		0.36		
		0/10	0.5		10	1.6		1.3	2.6		0.9		
		0/15	1.5		15	4.2		3.4	6.8		2.4		
	E, F types	0/ 5	0.4		5	0.52		0.44	1		0.36		
		0/10	0.5		10	1.3		1.1	2.6		0.9		
		0/15	1.5		15	3.6		3.0	6.8		2.4		
I _{IH} / I _{IL}	Input leakage current	G, H types	0/18	Any input	18		± 0.1		$\pm 10^{-5}$	± 0.1		± 1	
		E, F types	0/15		15		± 0.3		$\pm 10^{-5}$	± 0.3		± 1	
C _I	Input capacitance		Any input						5	75		pF	

* T_{LOW} = -55°C for G, H devices; -40°C for E, F devices.* T_{HIGH} = +125°C for G, H devices; +85°C for E, F devices.

The Noise Margin for both "1" and "0" level is:

1 V min. with V_{DD} = 5 V2 V min. with V_{DD} = 10 V2.5 V min. with V_{DD} = 15 V

DYNAMIC ELECTRICAL CHARACTERISTICS

($T_{amb} = 25^{\circ}\text{C}$, $C_L = 50 \text{ pF}$, $R_L = 200 \text{ k}\Omega$, typical temperature coefficient for all V_{DD} values is $0.3\%/^{\circ}\text{C}$, all input rise and fall time = 20 ns)

PARAMETER	TEST CONDITIONS			VALUES			UNIT
	R_X (k Ω)	C_X (pF)	V_{DD} (V)	Min.	Typ.	Max.	
t_{PLH} Trigger propagation delay	5 to	≥ 15	5		250	500	ns
t_{PHL} time (+TR, -TR to Q, \bar{Q})	10 000		10		125	250	
			15		100	200	
t_{WH} Trigger pulse width	5 to	≥ 15	5	140	70		ns
t_{WL}	10 000		10	60	30		
			15	40	20		
t_{TLH} Transition time	5 to	≥ 15	5		100	200	
	10 000		10		50	100	
			15		40	80	
t_{THL} Transition time	5 to	15 to	5		100	200	ns
	10 000	10 000	10		50	100	
			15		40	80	
	5 to	0.01 μF	5		150	300	
	10 000	to	10		75	150	
		0.1 μF	15		65	130	
	5 to	0.1 μF	5		250	500	
	10 000	to	10		150	300	
		1 μF	15		80	160	
t_{PLH} Propagation delay time	5 to		5		225	450	ns
t_{PHL} (Reset)	10 000	> 15	10		125	250	
			15		75	150	
t_{WR} Pulse width (Reset)			5	200	100		ns
		15	10	80	40		
			15	60	30		
			5	1 200	600		
	100	1 000	10	600	300		
			15	500	250		
			5	50	25		μs
		0.1 μF	10	30	15		
			15	20	10		
t_r (TR) Rise or fall time (Trigger)			5 to 15			100	μs

PARAMETER	TEST CONDITIONS			VALUES			UNIT
	R _x (kΩ)	C _x (pF)	V _{DD} (V)	Min.	Typ.	Max.	
Pulse width match between circuits in same package	10	10 000	5		5	10	%
			10		7.5	15	
			15		7.5	15	

APPLICATIONS

Astable multivibrator with restart after reset capability

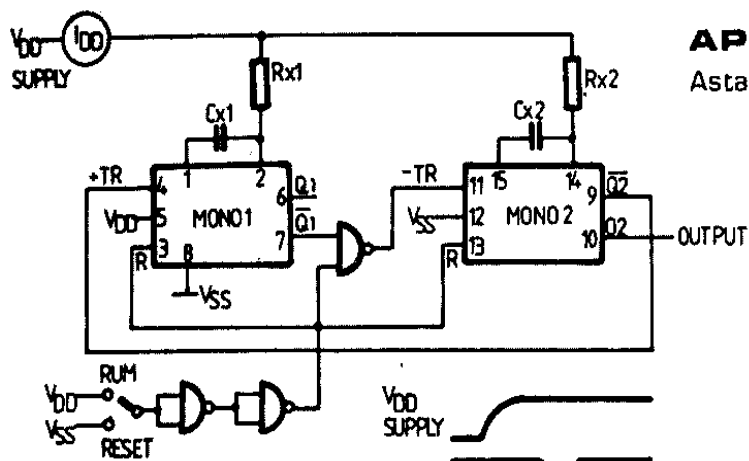

TO ENSURE RESTART APPLY RESET NEGATIVE PULSE AFTER VDD SUPPLY VOLTAGE HAS REACHED ITS VDD LEVEL

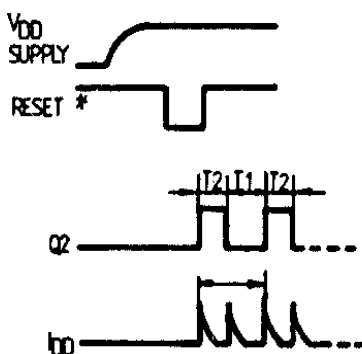

R _x	I _{DD} (Avg)	T _x (T1+T2)	V _{DD}
10 kΩ	1 mA / 0.05 mA	3.8 μs / 0.5 s	5 V
	2.5 mA / 0.5 mA	3.2 μs / 0.5 s	10 V
↓ 10 MΩ	5 mA / 1 mA	3 μs / 0.5 s	15 V

NOTE:
ALL VALUES ARE TYPICAL
C_x RANGE: 0,0001 μF TO
0,1 μF

Pulse delay

