

# MS1279

## RF & MICROWAVE TRANSISTORS TV/LINEAR APPLICATIONS

### Features

- 170- 230 MHz
- 25 VOLTS
- P<sub>OUT</sub> = 20 WATTS
- G<sub>p</sub> = 8.0 dB GAIN MINIMUM
- GOLD METALLIZATION
- INTERNAL INPUT MATCHING
- COMMON EMITTER CONFIGURATION

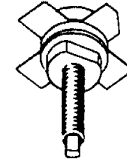

.500 4L STUD (M130)  
epoxy sealed

### DESCRIPTION:

The MS1279 is a gold metallized epitaxial silicon NPN planar transistor using diffused emitter ballast resistors for high linearity Class AB operation in VHF and Band III television transmitters and transposers.

#### PIN CONNECTION

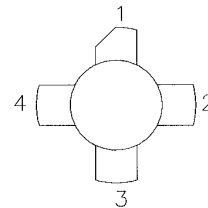

1. Collector      3. Base  
2. Emitter        4. Emitter

### ABSOLUTE MAXIMUM RATINGS (T<sub>case</sub> = 25°C)

Symbol	Parameter	Value	Unit
V <sub>CEO</sub>	Collector-Emitter Voltage	35	V
V <sub>CES</sub>	Collector-Emitter Voltage	60	V
V <sub>EBO</sub>	Emitter-Base Voltage	4.0	V
I <sub>C</sub>	Device Current	8.0	A
P <sub>DISS</sub>	Power Dissipation	140	W
T <sub>J</sub>	Junction Temperature	+200	°C
T <sub>STG</sub>	Storage Temperature	-65 to +150	°C

### Thermal Data

R <sub>TH(J-C)</sub>	Thermal Resistance Junction-case	1.5	°C/W
----------------------	----------------------------------	-----	------

## ELECTRICAL SPECIFICATIONS (T<sub>case</sub> = 25°C)

### STATIC

Symbol	Test Conditions		Value			Unit
			Min.	Typ.	Max.	
<b>BV<sub>CBO</sub></b>	<b>I<sub>C</sub> = 50mA</b>	<b>I<sub>E</sub> = 0mA</b>	<b>65</b>	---	---	<b>V</b>
<b>BV<sub>CER</sub></b>	<b>I<sub>C</sub> = 50mA</b>	<b>R<sub>BE</sub> = 10Ω</b>	<b>60</b>	---	---	<b>V</b>
<b>BV<sub>CEO</sub></b>	<b>I<sub>C</sub> = 50mA</b>	<b>I<sub>B</sub> = 0mA</b>	<b>35</b>	---	---	<b>V</b>
<b>BV<sub>EBO</sub></b>	<b>I<sub>E</sub> = 10mA</b>	<b>I<sub>C</sub> = 0mA</b>	<b>4.0</b>	---	---	<b>V</b>
<b>I<sub>CES</sub></b>	<b>V<sub>CE</sub> = 50V</b>	<b>I<sub>E</sub> = 0mA</b>	---	---	<b>5</b>	<b>mA</b>
<b>HFE</b>	<b>V<sub>CE</sub> = 5V</b>	<b>I<sub>C</sub> = 1A</b>	<b>20</b>	---	<b>120</b>	---

### DYNAMIC

Symbol	Test Conditions			Value			Unit
				Min.	Typ.	Max.	
<b>P<sub>OUT</sub></b>	<b>f = 225 MHz</b>	<b>V<sub>CE</sub> = 25 W</b>	<b>I<sub>C</sub> = 2.5 mA</b>	<b>20</b>	---	---	<b>W</b>
<b>G<sub>P</sub></b>	<b>f = 225 MHz</b>	<b>V<sub>CE</sub> = 25 W</b>	<b>I<sub>C</sub> = 2.5 mA</b>	<b>8.0</b>	---	---	<b>dB</b>
<b>IMD<sub>3</sub></b>	<b>P<sub>OUT</sub> = 14W</b>	<b>V<sub>CE</sub> = 25 W</b>	<b>I<sub>C</sub> = 2.5 mA</b>	---	<b>-55</b>	---	<b>dBc</b>
<b>C<sub>OB</sub></b>	<b>f = 1 MHz</b>	<b>V<sub>CB</sub> = 30 V</b>		---	---	<b>85</b>	<b>pF</b>

Note: \* dB compression

### IMPEDANCE DATA

FREQ	Z <sub>IN</sub> (Ω)	Z <sub>CL</sub> (Ω)
<b>150 MHz</b>	<b>1.0 + j1.0</b>	<b>9.0 + j5.0</b>
<b>250 MHz</b>	<b>1.0 + j2.0</b>	<b>6.0 + j6.0</b>

**V<sub>CE</sub> = 28V**  
**I<sub>C</sub> = 2.5A**  
**P<sub>OUT</sub> = 20W**

**TYPICAL PERFORMANCE**

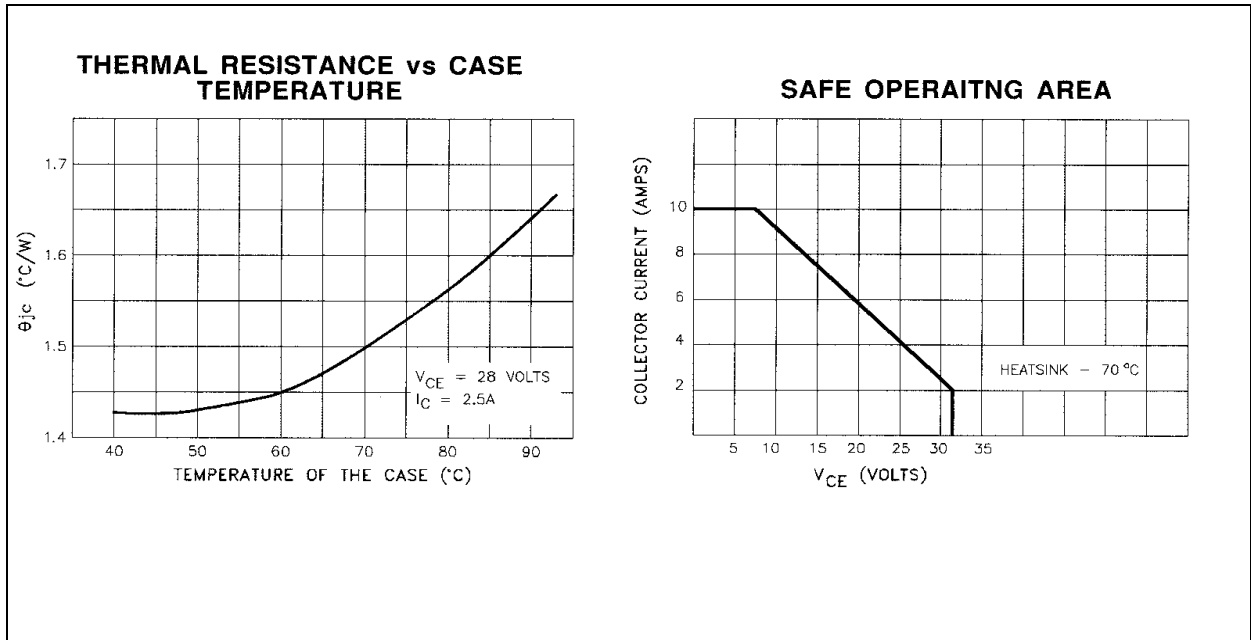
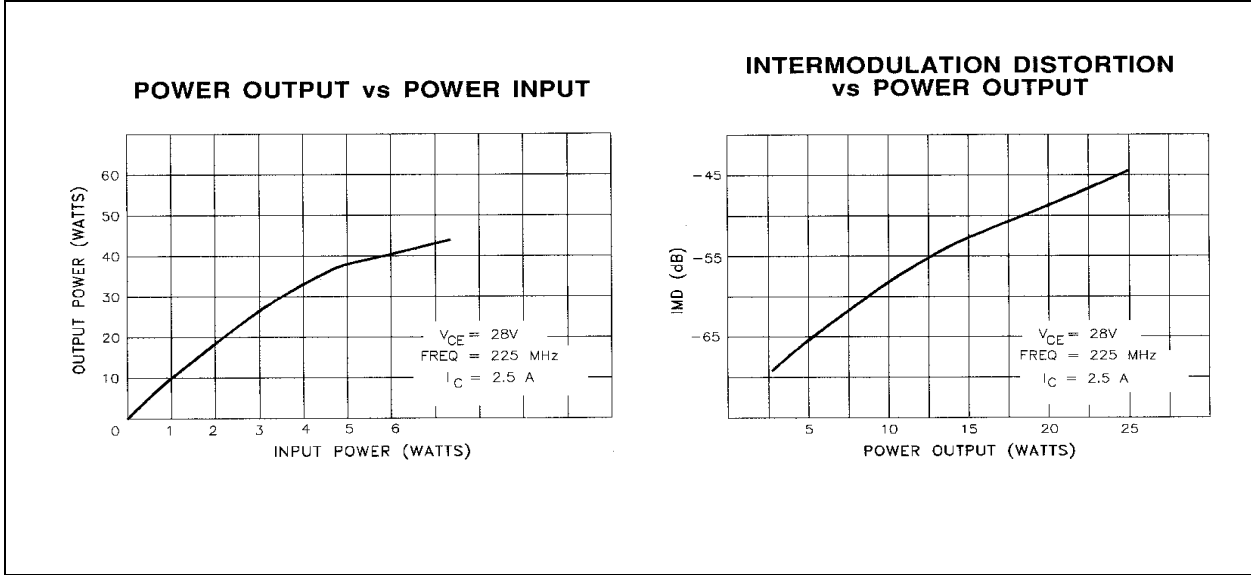

**PACKAGE MECHANICAL DATA**

PACKAGE STYLE M130

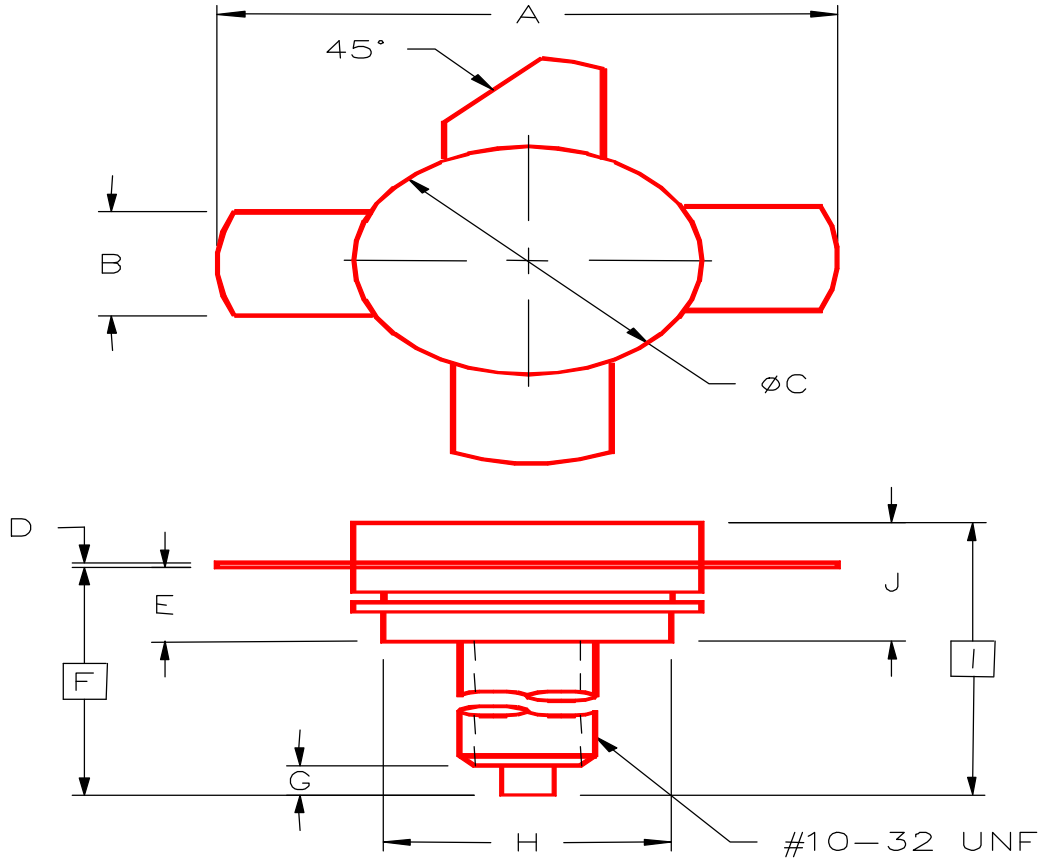

	MINIMUM INCHES/MM	MAXIMUM INCHES/MM		MINIMUM INCHES/MM	MAXIMUM INCHES/MM
A	1.010/25,65	1.050/26,67	I	.720/18,29	
B	.220/5,59	.230/5,84	J	.250/6,35	.290/7,37
C	.495/12,57	.505/12,83			
D	.003/0,08	.007/0,18			
E	.160/4,06	.180/4,57			
F	.622/15,80				
G	.100/2,54	.130/3,31			
H	.415/10,54	.425/10,80			