

FEATURES

- Excellent Power Supply Rejection Ratio(PSRR)
- Voltage Output
- Space saving package(SOP8)
- Low power consumption
- Low total harmonic distortion
- Wide dynamic range(16-bit resolution)
- No zero crossing distortion
- Wide operating temperature range(-40°C to 85°C)
- Internal bias current ensures maximum dynamic range
- Fast setting time permits 2*, 4*, and 8* oversampling(serial input) or double speed operation at 4* oversampling
- Compatible with most of the Japanese input formats; time multiplexed, two's complement, TTL
- The full scale output voltage can be mask optioned
- Cost efficient
- Easy application :
Operation range: 2.7V~5.5V
Output and bias current are proportional to supply voltage
integrated current-to-voltage converter

APPLICATIONS

VCD Player, DVD Player, CD-ROM, DVD-ROM, CD-RW, DVD-RW, Motherboard, MP3, PDA, Portable Digital Audio.

DESCRIPTION

The MS6313 is a 16-bit voltage-output Digital-to-Analog Converter(DAC). The MS6313 is with excellent Power Supply Rejection Ratio(PSRR). It is fabricated in a 0.8μm CMOS process and features extremely low power dissipation, small package size and easy application. The accuracy of the matched coarse current sources, combined with the unique symmetrical decoding method, preclude zero-crossing distortion and ensures high quality audio reproduction. These unique features, combined with its exceptional performance, make the MS6313 ideally suited for use in digital audio equipment. MS6313 is pin and function compatible with the Philips, TDA1311.

PINNING

Symbol	Pin	Description
BCK	1	bit clock input
WS	2	word select input
DATA	3	data input
GND	4	ground
V _{DD}	5	positive supply voltage
V _{OL}	6	left channel output
Cap	7	Cap
V _{OR}	8	right channel output

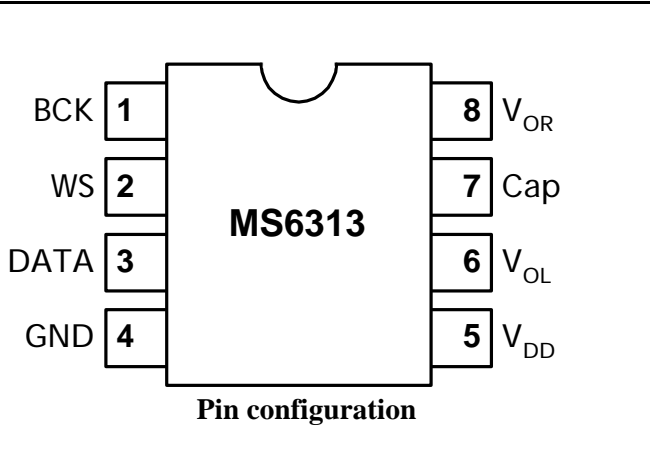

Pin configuration

Pin 7 : Capacitor = 10μF (ripple rejection)

BLOCK DIAGRAM

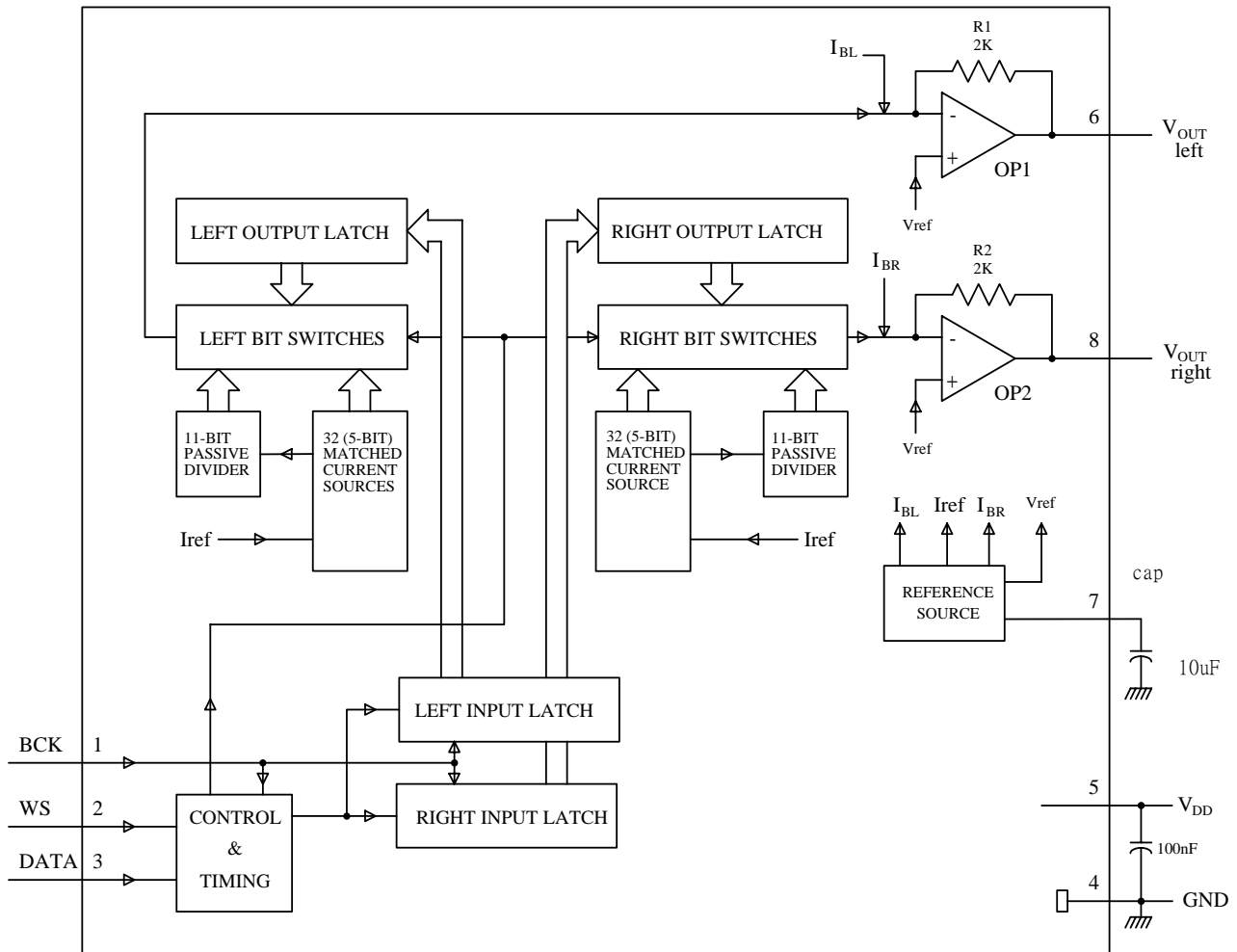

Fig.1 Block diagram.

LIMITING VALUES

Symbol	Parameter	Rating	Unit
VDD	Positive Supply Voltage	6	V
T _{STG}	Storage Temperature Range	-65 to 150	°C
T _A	Operating Ambient Temperature Range	-40 to 85	°C
T _J	Maximum Junction Temperature	150	°C
T _S	Soldering Temperature, 10 seconds	260	°C
T _{ESD}	Electrostatic Handling	-2000 to 2000	V
R _{THJA}	Thermal Resistance from Junction to Ambient in Free Air SOP8	210	°C/W

ELECTRICAL CHARACTERISTICS

(Ta=25°C, V_{DD}=5V)

Symbol	Parameter	Conditions	Min	Typ	Max	Unit
V _{DD}	Positive Supply Voltage		2.7	5	5.5	V
I _{DD}	Operating Current	at code 0000H	-	3.4	6.0	mA

DIGITAL INPUTS (WS, BCK, DATA)

Symbol	Parameter	Conditions	Min	Typ	Max	Unit
I _{IL}	Input Leakage Current LOW	V _I =0.8V	-	-	10	μA
I _{IH}	Input Leakage Current HIGH	V _I =2.4V	-	-	10	μA
f _{BCK}	Input Clock Frequency		-	-	18.4	MHz
BR	Bit Rate Data Input (Pin 3)		-	-	18.4	Mbits/s
f _{ws}	Word Select Input (Pin 2)		-	-	384	kHz
t _r	Rise Time		-	-	12	ns
t _f	Fall Time		-	-	12	ns
t _{Cr}	Bit Clock Cycle Time		54	-	-	ns
t _{HB}	Bit Clock High Time		15	-	-	ns
t _{LB}	Bit Clock Low Time		15	-	-	ns
t _{SD}	Data Set-up Time		12	-	-	ns
t _{HD}	Data Hold Time to Bit Clock		2	-	-	ns
t _{HW}	Word Select Hold Time		2	-	-	ns
t _{SW}	Word Select Set-up Time		12	-	-	ns

ANALOG OUTPUTS (V_{OL}, V_{OR})

Symbol	Parameter	Conditions	Min	Typ	Max	Unit
Res	Resolution		-	-	16	bits
V _{FS}	Full Scale Output Voltage	V _{FS} =0.4V _{DD}	1.8	2.0	2.2	V
T _{CFS}	Full Scale Temperature Coefficient at Analog Outputs ; V _{OL} , V _{OR}		-	±400	-	10 ⁻¹⁶
V _{DC}	Output Bias		-	2.5	-	V
THD	Total Harmonic Distortion	including noise	-	-68	-63	dB
		at 0 dB; note 1	-	0.04	0.07	%
THD	Total Harmonic Distortion	including noise	-	-30	-24	dB
		at -60 dB; note 1	-	3	6	%
CS	Channel Separation		75	80	-	dB
I _{dIo}	Unbalance Between Outputs	note 1	-	0.2	0.3	dB
I _{td}	Time Delay Between Outputs		-	±0.2	-	μs
S/N	Signal-to-Noise Ratio	a-weighted at code 0000H	86	92	-	dB

Note : 1.Measured with 1kHz sinewave generated at sampling rate of 192 kHz.

TYPICAL PERFORMANCE CHARACTERISTICS

($T_a=25^\circ\text{C}$, $R_L=32\Omega$, sampling rate=4fs; unless otherwise specified)

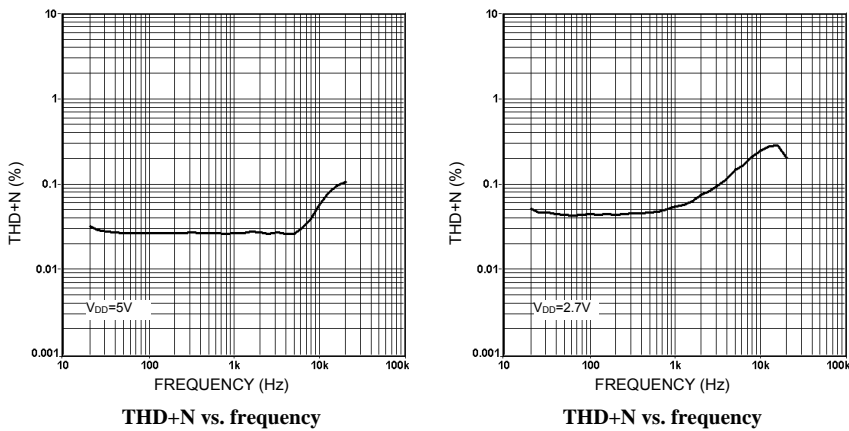

TIMING AND DATA FORMAT

The MS6313 accepts input serial data formats of 16-bit word length. Left and right data words are time multiplexed. The MSB (bit 1) must always be first. The format of data input is shown in Figs. 2 and 3. With a HIGH level on the word select input (WS), data is placed in the left input register and with LOW level on the WS input, data is placed in the right register (Fig. 1). The data in the input registers are simultaneously latched in the output registers which control the bit switches. Internal bias currents I_{BL} and I_{BR} are each added to the full scale output current I_{FS} in order to achieve the maximum dynamic range at the outputs of OP1 and OP2(Fig. 1). The reference voltage V_{ref} (Fig. 1) is approximately $2/3 V_{DD}$. In this way the maximum dynamic range is achieved over the entire power supply range.

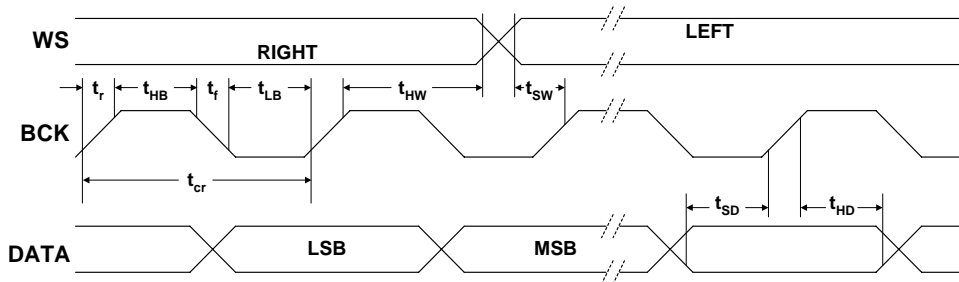

Fig.2 Timing and input signals.

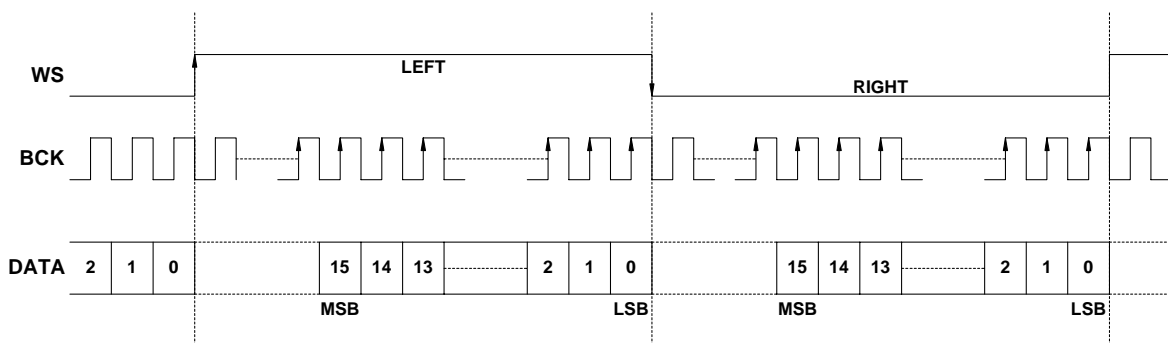

Fig.3 Format of input signals.

APPLICATION INFORMATION

Basic application example

A typical example of a CD-application with the MS6313 is shown in Fig.4. It features typical decoupling components and a second-order analog post-filter (smoothing filter) stage providing a line output.

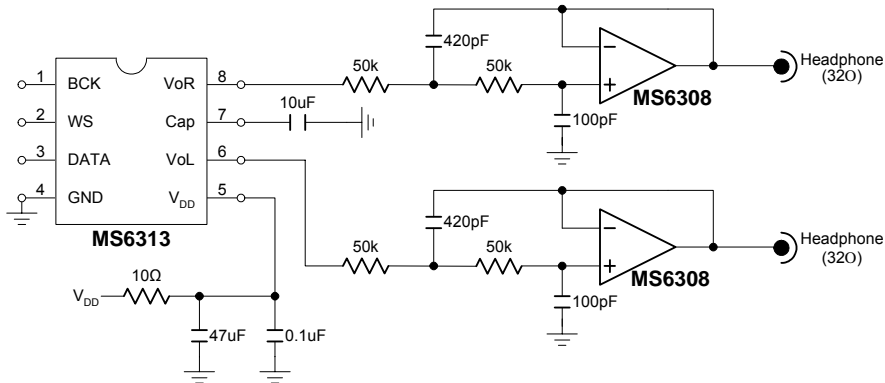

Fig.4 Example of a 2nd order filter application.

Note : No external capacitor loading is allowed at the output pins 6 and 8.

MP3 digital to analog converting solution. Fig.5 , 6

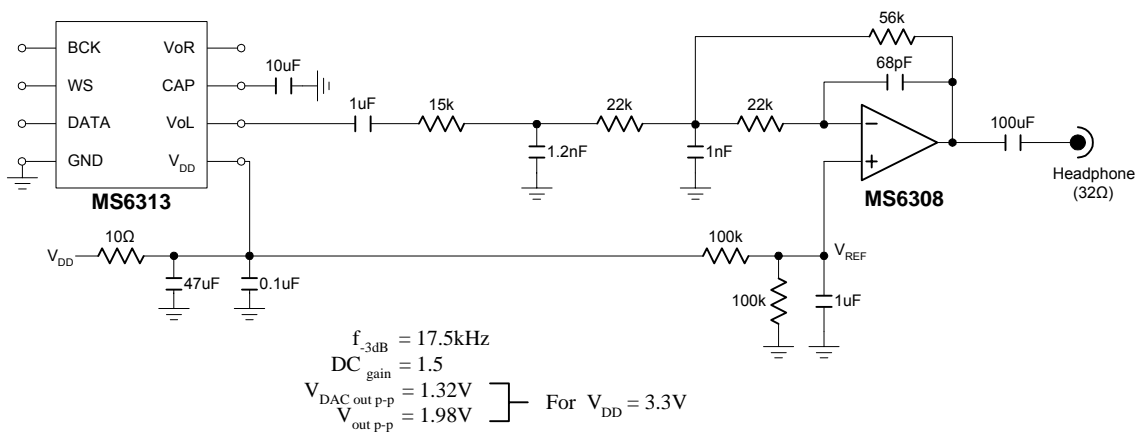

Fig.5 A third order lowpass filter (Smoothing filter) for DAC output.

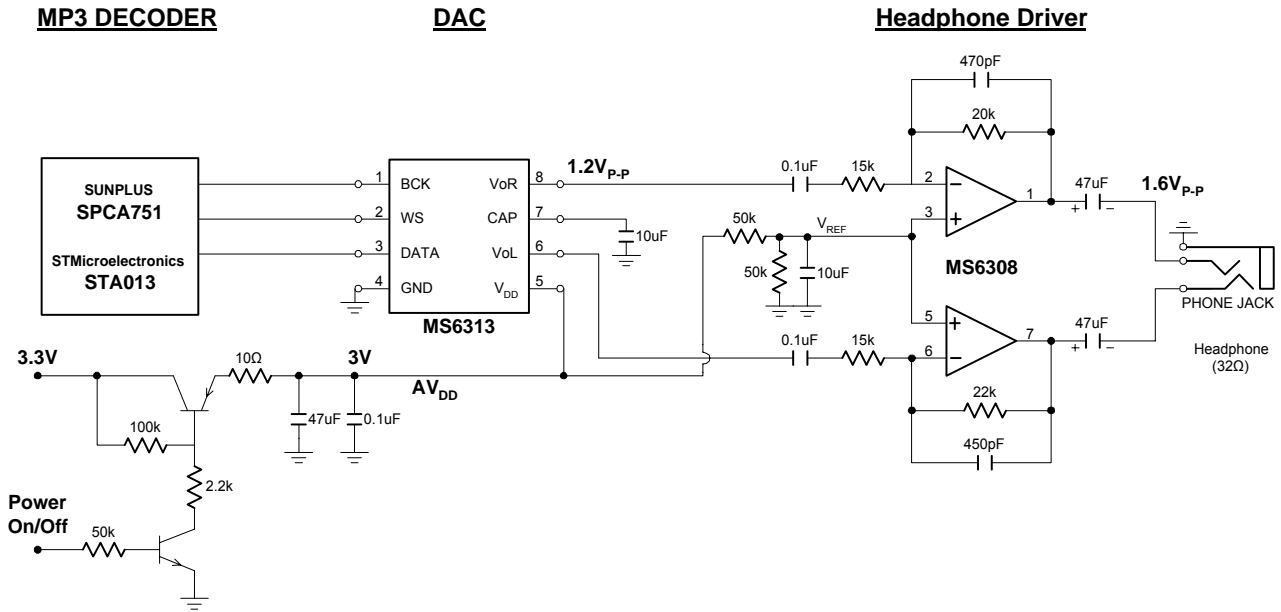

Fig.6 A first order lowpass filter for DAC output.

VCD , DVD Player digital to analog converting solution. Fig.7

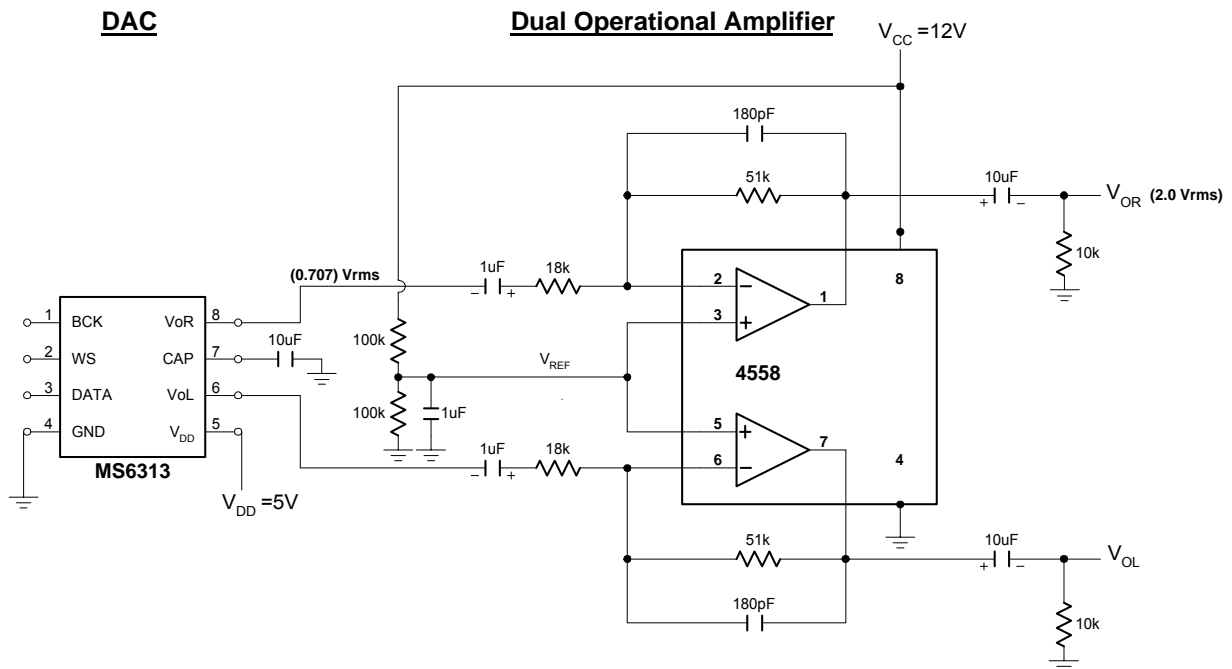
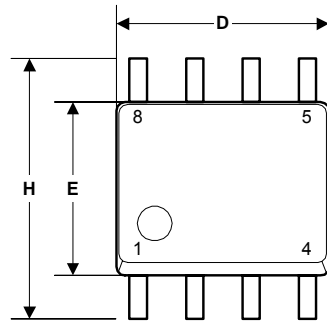
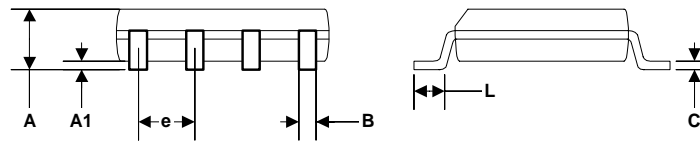

Fig.7 A first order lowpass filter for DAC output.

EXTERNAL DIMENSIONS



Symbol	Dimension in mm		Dimension in inch	
	Min	Max	Min	Max
A	1.35	1.75	0.0532	0.0688
A1	0.10	0.25	0.0040	0.0098
B	0.33	0.51	0.013	0.020
C	0.19	0.25	0.0075	0.0098
e	1.27 BSC		0.050 BSC	
D	4.80	5.00	0.1890	0.1968
H	5.80	6.20	0.2284	0.2440
E	3.80	4.00	0.1497	0.1574
L	0.40	1.27	0.016	0.050



TAPE AND REEL (Unit : mm)

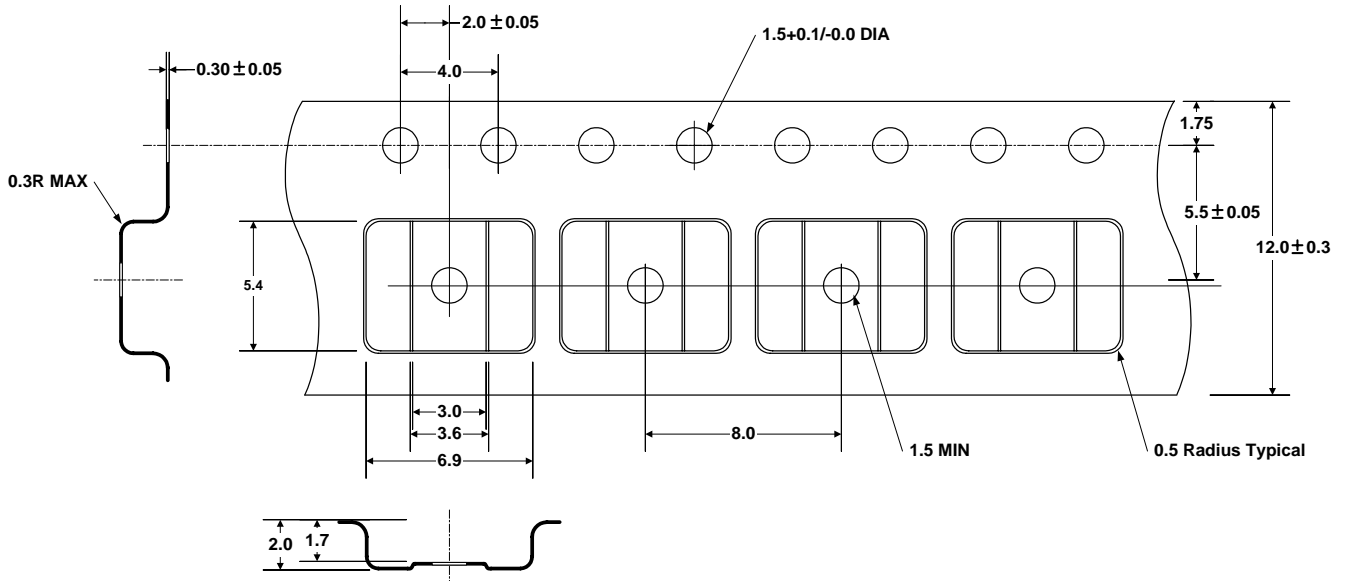

ORDERING INFORMATION

Package	Part number	Packaging Marking	Transport Media
8-Pin SOP	MS6313ASTR	MS6313AS	2.5k Units Tape and Reel
8-Pin SOP	MS6313ASU	MS6313AS	100 Units Tube
8-Pin SOP (lead free)	MS6313ASGTR	MS6313ASG	2.5k Units Tape and Reel
8-Pin SOP (lead free)	MS6313ASGU	MS6313ASG	100 Units Tube