

Mounting Instruction

MSA 002, 003

Important!

- The measuring length of the Linear Encoder must be longer than the travel length of the machine!
- Remove transport brackets prior to operation
- Never tilt the encoder head with respect to the extrusion
- Do not connect or disconnect the encoder head with the Digital Readout or Control if the power is on.
- The Linear Encoder is not protected against dust and water drops.
- Do not touch the connector pins! (ESD-Instruction)
- Overall cable length should not exceed 30 m!

Mounting notes

- The best location for mounting a Linear Encoder is to mount it as close to the centerline of the slide, or as close to the guideways of the machine, as possible.
- To mount the Linear Encoder, two mounting surfaces are required; one for the extrusion and one for the encoder head. If the unit cannot be mounted directly onto the slide, then mounting brackets would be required.
- Mount the Linear Encoder so that the encoder head never runs into the end of the extrusion, for overtraveling the measuring length will destroy the unit!
- If possible, the extrusion should be mounted on the moving part of the machine guideway and the encoder head fixed, so that the cable is rigidly attached to the machine and continuous cable flexure and the chance of a cable snag are eliminated.

Mounting of the extrusion

- First, mount the extrusion and loosely tighten the mounting screws.
- Adjust the mounting so that the extrusion is parallel to the machine guideway, and tighten the mounting screws according to the specifications.

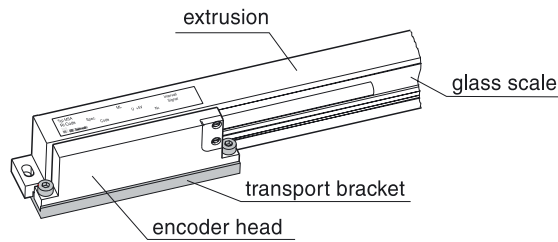

Mounting of the encoder head

- Move the encoder head carefully by hand to the mounting surface.
- Initially, lightly tighten the screws.
- Adjust the encoder head gap to the mounting gap and tolerance (1 mm gap), and tighten the mounting screws according to the specifications.

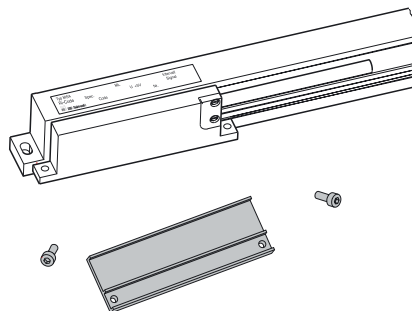

Inspection of the mounting

- Move the slide over the full range of motion to make sure that full machine movement range can be obtained without the encoder contacting the end of the scale extrusion. Otherwise, the Linear Encoder will be damaged!

Tying down the cables

- Lay the cable so that the minimal bending radius is not exceeded.
When you have mounted the encoder head at the moving part of your machine, the cable should be laying in a drag-chain.
- Overall cable length should not exceed 30 m!

Dimensions - Mounting tolerances - Mounting possibilities:

