



M.S.KENNEDY CORP.

**10 AMP, 75 VOLT MOSFET  
SMART POWER 3-PHASE  
MOTOR DRIVE HYBRID**

**4303**

4707 Dey Road Liverpool, N.Y. 13088

(315) 701-6751

**FEATURES:**

- 75V, 10 Amp Capability
- Ultra Low Thermal Resistance - Junction to Case - 1.5°C/W (Each MOSFET)
- Self-Contained, Smart Lowside/Highside Drive Circuitry
- Bootstrap High-Side Supplies
- Under-Voltage Lockout
- Capable of Switching Frequencies to 25KHz
- Isolated Case Allows Direct Heat Sinking
- Bolt-down Design Allows Superior Heat Dissipation

**MIL-PRF-38534 CERTIFIED**

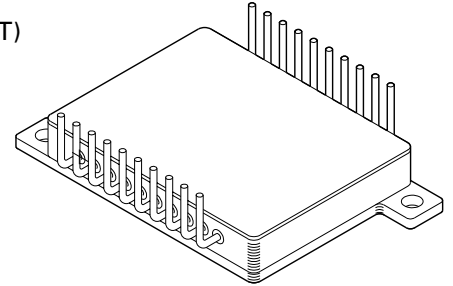

**DESCRIPTION:**

The MSK 4303 is a 10 Amp, 3 Phase Bridge Smart Power Motor Drive Hybrid with a 75 volt rating on the output switches. The output switches are MOSFETs. This new smart power motor drive hybrid is 5.0 volt input logic compatible. Under-voltage lockout shuts down the bridge when the supply voltage gets to a point of incomplete turn-on of the output switches. The internal high-side bootstrap power supply derived from the +VB supply completely eliminates the need for 3 floating independent power supplies.

**EQUIVALENT SCHEMATIC**

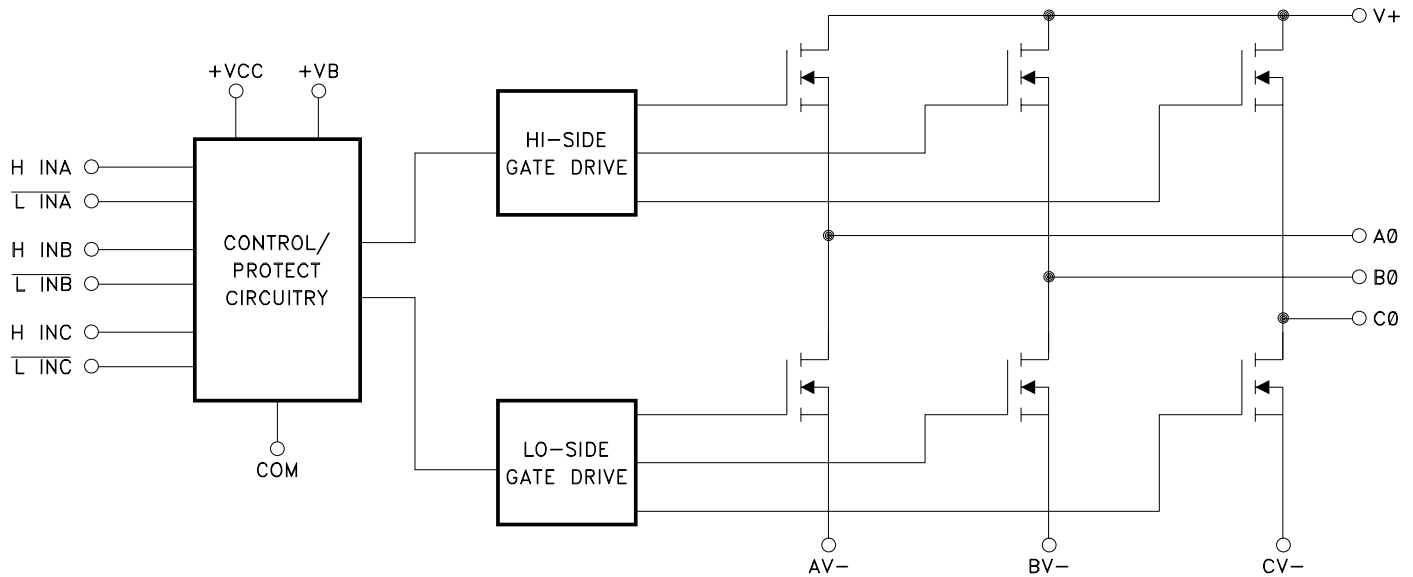

**TYPICAL APPLICATIONS**

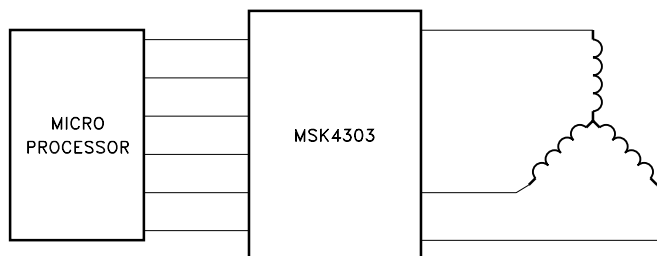

**3 PHASE SIX STEP DC BRUSHLESS MOTOR DRIVE  
OR 3 PHASE SINUSOIDAL INDUCTION MOTOR DRIVE**

**PIN-OUT INFORMATION**

1 H INA	20 V +
2 L INA	19 N/C
3 +VCC	18 AV-
4 H INB	17 AØ
5 L INB	16 N/C
6 COM	15 BV-
7 COM	14 BØ
8 +VB	13 N/C
9 H INC	12 CV-
10 L INC	11 CØ

## ABSOLUTE MAXIMUM RATINGS <sup>⑥</sup>

V+	High Voltage Supply	75V
VCC	Logic Supply	18V
IOUT	Continuous Output Current	10A
IPK	Peak Output Current	14A
θJC	Thermal Resistance @ 125°C (Output Switches)(Junction to Case)	1.5°C/W

TsT	Storage Temperature Range	-65° to +150°C
TLD	Lead Temperature Range	
TC	(10 Seconds) Case Operating Temperature	300°C
	MSK 4303	-40°C to +85°C
	MSK 4303H/E	-55°C to +125°C
TJ	Junction Temperature	+150°C

## ELECTRICAL SPECIFICATIONS

Parameters	Test Conditions	GROUP A SUBGROUP ⑤	MSK 4303H/E ③			MSK 4303 ②			UNITS
			Min.	Typ.	Max.	Min.	Typ.	Max.	
<b>OUTPUT CHARACTERISTICS</b>									
Drain-Source ON Resistance ① (each MOSFET) (for thermal calculations only)	Ic = 10A	1	-	-	0.013	-	-	0.013	Ω
		2	-	-	0.026	-	-	-	Ω
		3	-	-	0.013	-	-	-	Ω
Drain-Source Voltage (VDS(on)) (each MOSFET)	Ic = 10A	1	-	0.56	1.2	-	0.56	1.4	volts
		2	-	0.78	1.5	-	-	-	volts
		3	-	0.42	1.0	-	-	-	volts
Leakage Current (Each MOSFET)	V+ = 75V	1	-	1	25	-	1	25	μA
	V+ = 75V	2	-	10	250	-	-	-	mA
	V+ = 75V	3	-	1	25	-	-	-	mA
Reverse Recovery Time ①	ID = 10A, di/dt = 100A/μS	-	-	120	-	-	120	-	nS
<b>BIAS SUPPLY CHARACTERISTICS</b>									
+Vcc Bias Current	+Vcc = 15V	1,2,3	-	12	20	-	12	20	mA
+VB Bias Current	+VB = 15V	1,2,3	-	6	9	-	6	9	mA
<b>INPUT SIGNAL CHARACTERISTICS</b>									
Positive Trigger Threshold Voltage ①	+Vcc = 15V	-	2.7	-	-	2.7	-	-	volts
Negative Trigger Threshold Voltage ①	+Vcc = 15V	-	-	-	0.8	-	-	0.8	volts
Under-voltage Lockout	+Vcc Positive Going Threshold	1,2,3	8.0	8.9	9.8	8.0	8.9	9.8	volts
	+Vcc Negative Going Threshold	1,2,3	7.4	8.2	9.0	7.4	8.2	9.0	volts
Dead Time ①	Low Side Turn-off to High Side Turn-On	-	280	400	520	280	400	520	nSEC
	High Side Turn-off to Low Side Turn-On	-	4	5	6	4	5	6	μSEC

### NOTES:

- ① Guaranteed by design but not tested. Typical parameters are representative of actual device performance but are for reference only.
- ② Industrial grade and "E" suffix devices shall be tested to subgroups 1 and 4 unless otherwise specified.
- ③ Military grade devices ("H" suffix) shall be 100% tested to subgroups 1, 2 and 3.
- ④ Subgroups 5 and 6 testing available upon request.
- ⑤ Subgroup 1, 4 TA=TC = +25°C  
2, 5 TA=TC = +125°C  
3, 6 TA=TC = -55°C
- ⑥ Continuous operation at or above absolute maximum ratings may adversely effect the device performance and/or life cycle.

# TYPICAL PERFORMANCE CURVES

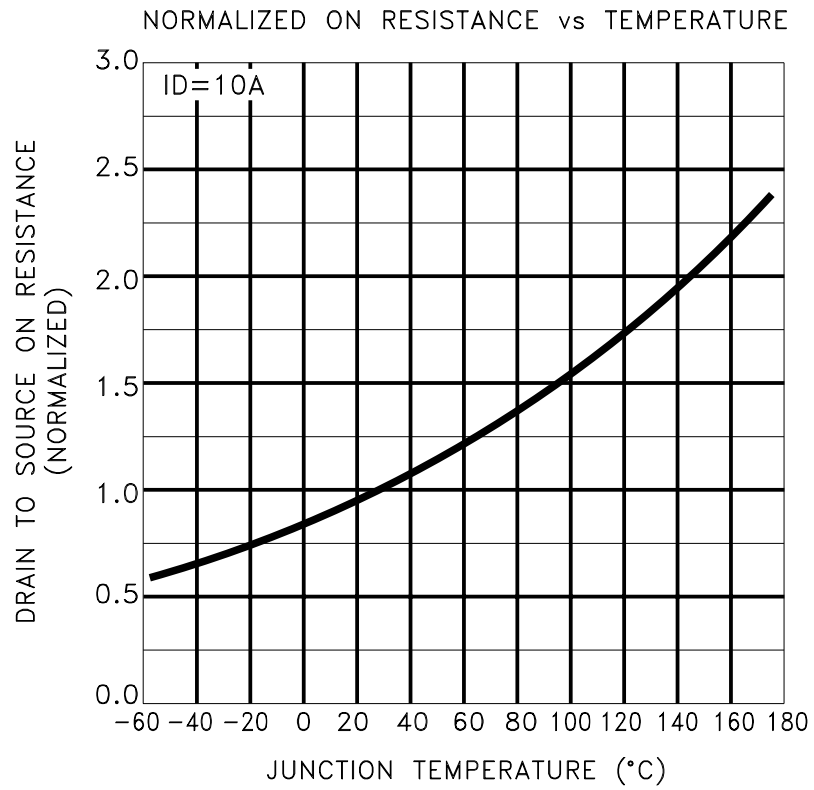

## APPLICATION NOTES

### *MSK 4303 PIN DESCRIPTIONS*

**+VCC** - Is the low voltage supply for all the internal logic and drivers. A 0.1  $\mu$ F ceramic capacitor in parallel with a 10 $\mu$ F tantalum capacitor is the recommended bypassing from the +VCC pin to the COM pin.

**H INA, H INB, H INC** - Are high active logic inputs for signalling the corresponding phase high-side switch to turn on. The logic inputs are compatible with standard CMOS or LSTTL outputs. These logic inputs are internally zener clamped at 5.2 volts.

**L INA, L INB, L INC** - Are low active logic inputs for signalling the corresponding phase low-side switch to turn on. The logic inputs are compatible with standard CMOS or LSTTL outputs. These logic inputs are internally zener clamped at 5.2 volts.

**A $\emptyset$ , B $\emptyset$ , C $\emptyset$**  - Are the pins connecting the 3 phase bridge switch outputs.

**AV-, BV-, CV-** - Are the connections from the bottoms of the three half bridges. These pins get connected to the COM pin. If current sensing is desired they may be connected to the COM pin through a low value sense resistor.

**+VB** - Is the connection used to provide power to the floating high-side bootstrap supplies in the gate drive circuitry.

**V+** - Is the high voltage positive rail connection to the tops of the three half bridges. Proper power supply bypassing must be connected from this pin to the COM pin for good filtering. This bypassing must be done as close to the hybrid as possible.

**COM** - Is the connection that all hybrid power supply connections are returned to and bypassed to.

## TYPICAL SYSTEM OPERATION

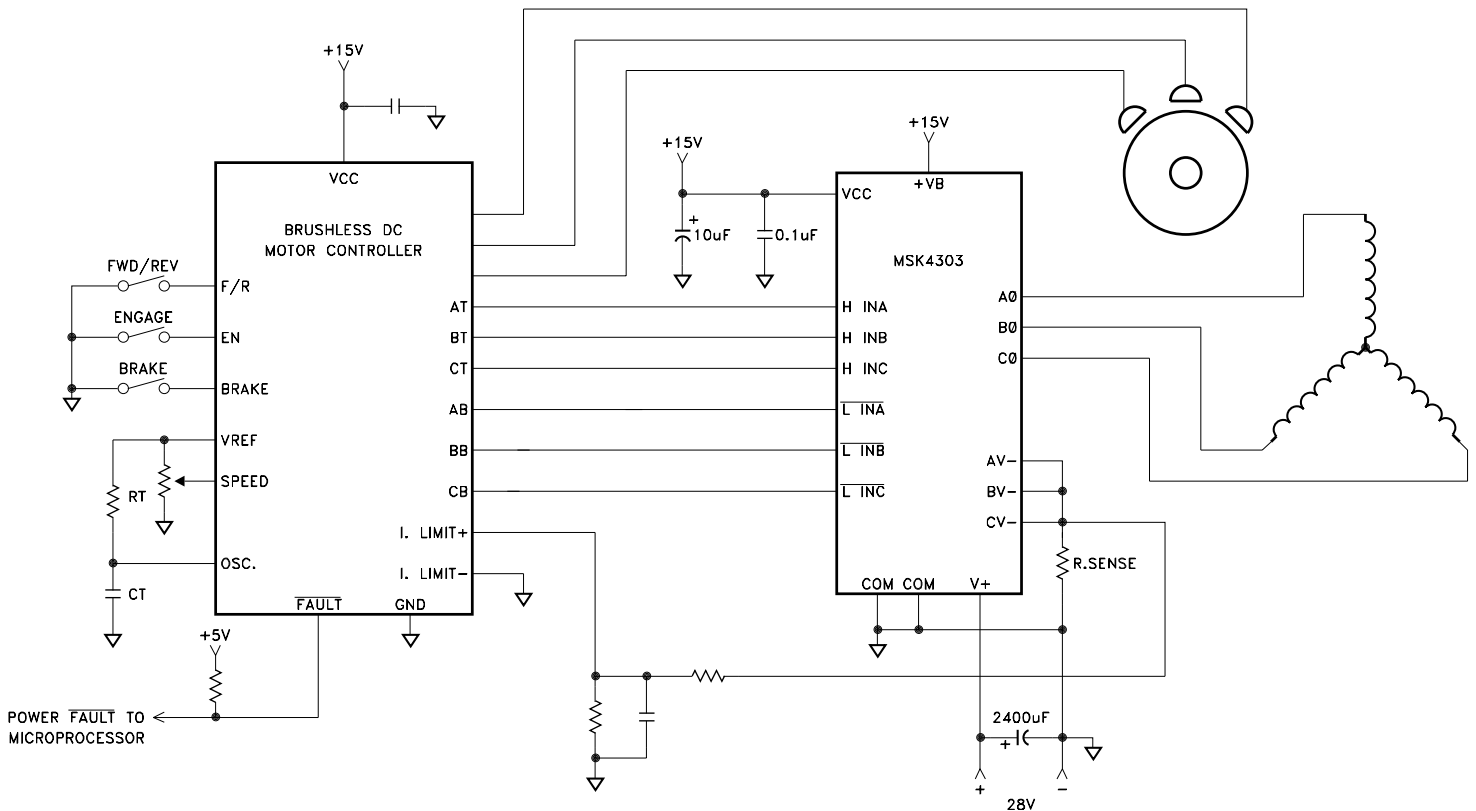

The MSK 4303 is designed to be used with a +28 volt high voltage bus, +15 volt low power bus and +5 volt logic signals. Proper derating should be applied when designing the MSK 4303 into a system. High frequency layout techniques with ground planes on a printed circuit board is the only method that should be used for circuit construction. This will prevent pulse jitter caused by excessive noise pickup on the current sense signal or the error amp signal.

Ground planes for the lower power circuitry and the high power circuitry should be kept separate. The connection between the bottom of the current sense resistor, COM pin and the high power ground, AV-, BV- and CV- pins are connected at this point. This is a critical path and high currents should not be flowing between the current sense and COM. Inductance in this path should be kept to a minimum. An RC filter (shown in 2 places) will filter out the current spikes and keep the detected noise for those circuits down to a minimum.

In the system shown a PWM pulse by pulse current limit scheme controlled by the motor controller is implemented.

When controlling the motor speed by the PWM method, it is required that the low side switches be PWM pulsed due to the bootstrap supplies used to power the high side switch drives. The higher the PWM speed the higher the current load on the drive supply. PWM of the low side will prevent sagging of the high side supplies. A separate pin (+VB) is provided for connecting an external floating power supply to power the bootstrap supplies.

## MECHANICAL SPECIFICATIONS

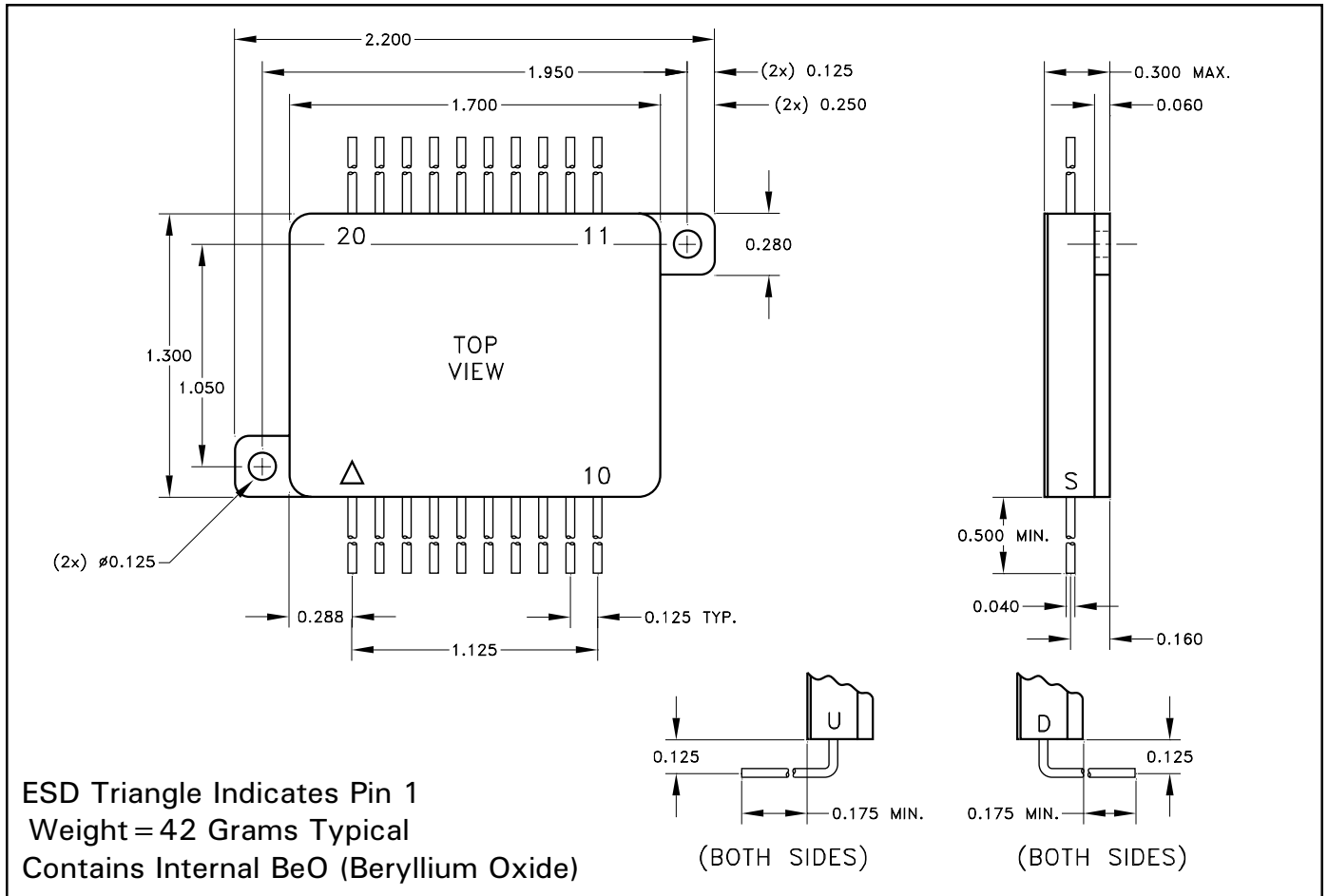

All dimensions are  $\pm 0.01$  inches unless otherwise specified.

## ORDERING INFORMATION

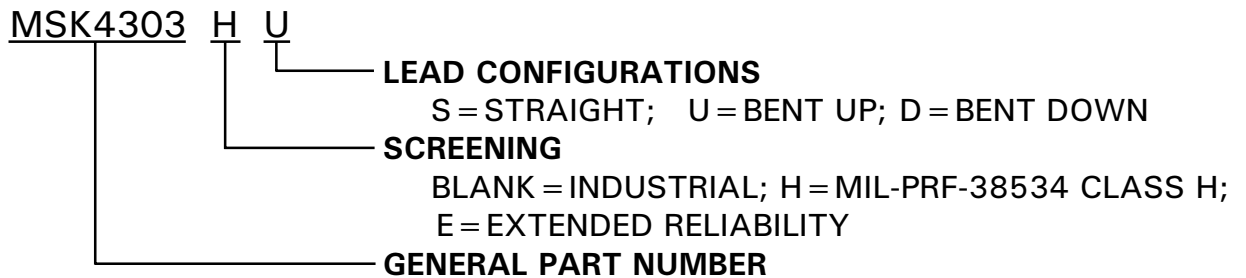

M.S. Kennedy Corp.  
 4707 Dey Road, Liverpool, New York 13088  
 Phone (315) 701-6751  
 FAX (315) 701-6752  
 www.mskennedy.com

The information contained herein is believed to be accurate at the time of printing. MSK reserves the right to make changes to its products or specifications without notice, however and assumes no liability for the use of its products. Please visit our website for the most recent version of this datasheet.