

**T-1 3/4 (f5mm)
HIGH POWER AlInGaP LED LAMPS**

MVL-5C4SO

Description

The MVL-5C4SO utilizes the latest absorbing substrate Aluminum Indium Gallium Phosphide (AlInGaP) LED technology. This LED material has outstanding light output efficiency over a wide range of drive current. The package is T-1 3/4 (5mm) water clear standard type.

Features

- Ultra - brightness
- Low power consumption
- TTL compatible
- Reliable

Package Dimensions

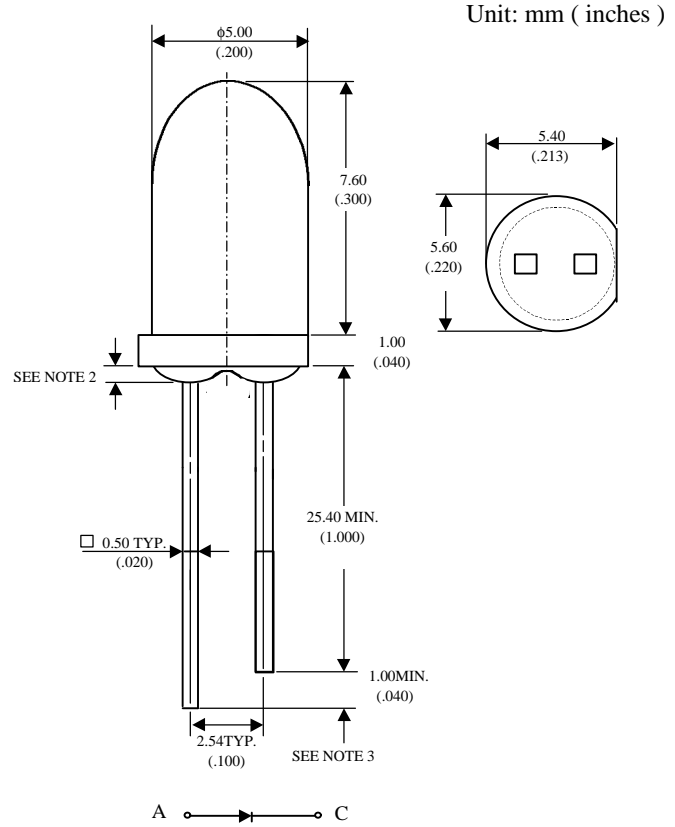

Notes :

1. Tolerance is ± 0.25 mm (.010") unless otherwise noted.
2. Protruded resin under flange is 1.5 mm (.059") max.
3. Lead spacing is measured where the leads emerge from the package.

Absolute Maximum Ratings

@ $T_A=25^\circ\text{C}$

Parameter	Maximum Rating	Unit
Power Dissipation	125	mW
Peak Forward Current(1/10 Duty Cycle 100 μ s pulse)	100	mA
Continuous Forward Current	50	mA
Reverse Voltage	5	V
Operating Temperature Range	-40 $^\circ\text{C}$ to +100 $^\circ\text{C}$	
Storage Temperature Range	-40 $^\circ\text{C}$ to +100 $^\circ\text{C}$	
Lead Soldering Temperature 1.6 mm from body for 5 seconds at 260 $^\circ\text{C}$		

Optical-Electrical Characteristics

@ $T_A=25^\circ\text{C}$

Parameter	Test Conditions	Symbol	Min .	Typ .	Max .	Unit .
Luminous Intensity	$I_F=20\text{mA}$	I_V	600	1500	-	mcd
Forward Voltage	$I_F=20\text{mA}$	V_F	-	1.9	2.4	V
Reverse Current	$V_R=5\text{V}$	I_R	-	-	100	μA
Wavelength	$I_F=20\text{mA}$	λ_p/λ_d	-	610/605	-	nm
Spectral Line Half Width	$I_F=20\text{mA}$	$\Delta\lambda$	-	20	-	nm
Viewing Angle	$I_F=20\text{mA}$	$2\theta_{1/2}$	-	30	-	deg.

Typical Optical-Electrical Characteristic Curves

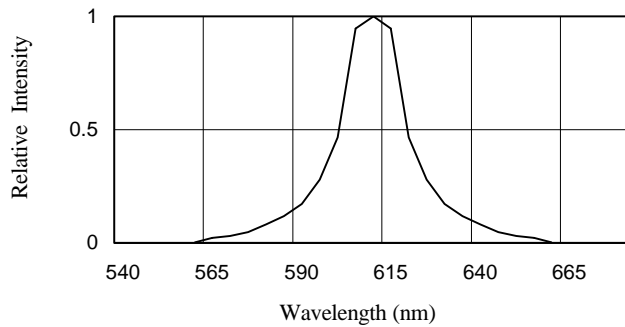

FIG.1 SPECTRAL DISTRIBUTION

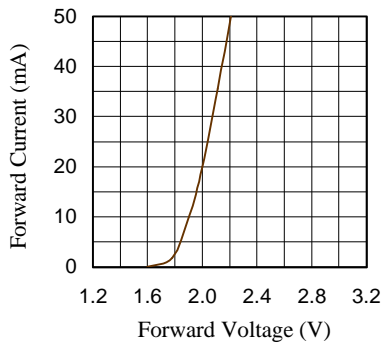

FIG.2 FORWARD CURRENT VS. FORWARD VOLTAGE

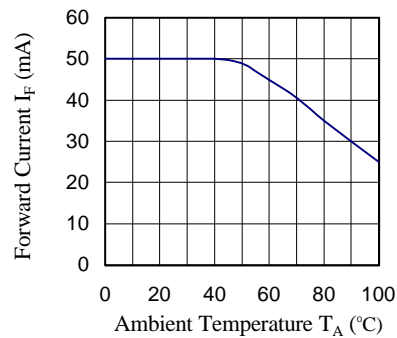

FIG.3 FORWARD CURRENT VS. AMBIENT TEMPERATURE

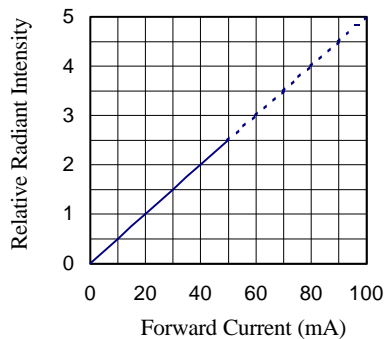

FIG.4 RELATIVE RADIANT INTENSITY VS. FORWARD CURRENT

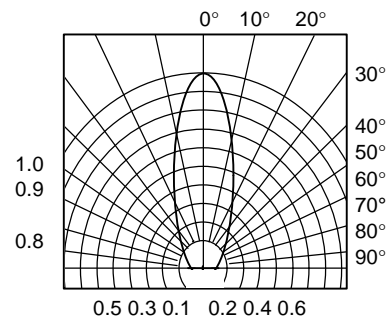

FIG.5 RADIATION DIAGRAM