

8Mb Ultra-Low Power Asynchronous CMOS SRAM

512K × 16 bit

Overview

The N08L163WC1C is an integrated memory device containing a 8 Mbit Static Random Access Memory organized as 524,288 words by 16 bits. The device is designed and fabricated using NanoAmp's advanced CMOS technology to provide both high-speed performance and ultra-low power. Byte controls (\overline{UB} and \overline{LB}) allow the upper and lower bytes to be accessed independently and can also be used to deselect the device. The N08L163WC1C is optimal for various applications where low-power is critical such as battery backup and hand-held devices. The device can operate over a very wide temperature range of -40°C to +85°C and is available in JEDEC standard packages compatible with other standard 512Kb x 16 SRAMs

Features

- **Single Wide Power Supply Range**
2.2 to 3.6 Volts
- **Very low standby current**
2.0µA at 3.0V (Typical)
- **Very low operating current**
1.5mA at 3.0V and 1µs(Typical)
- **Simple memory control**
Byte control for independent byte operation
Output Enable (\overline{OE}) for memory expansion
- **Low voltage data retention**
Vcc = 1.5V
- **Very fast output enable access time**
25ns \overline{OE} access time
- **Automatic power down to standby mode**
- **TTL compatible three-state output driver**
- **Ultra Low Power Sort Available**

Product Family

Part Number	Package Type	Operating Temperature	Power Supply (Vcc)	Speed	Standby Current (I _{SB}), Typical	Operating Current (I _{CC}), Typical
N08L163WC1CT1	44-TSOP II Pb-Free	-40°C to +85°C	2.2V - 3.6V	55ns	2 µA	1.5 mA @ 1MHz

Pin Configuration

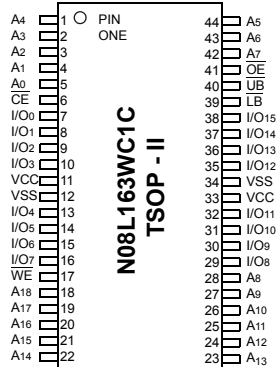

Pin Descriptions

Pin Name	Pin Function
A ₀ -A ₁₈	Address Inputs
\overline{WE}	Write Enable Input
\overline{CE}	Chip Enable Input
\overline{OE}	Output Enable Input
\overline{LB}	Lower Byte Enable Input
\overline{UB}	Upper Byte Enable Input
I/O ₀ -I/O ₁₅	Data Inputs/Outputs
V _{CC}	Power
V _{SS}	Ground
NC	Not Connected

Functional Block Diagram

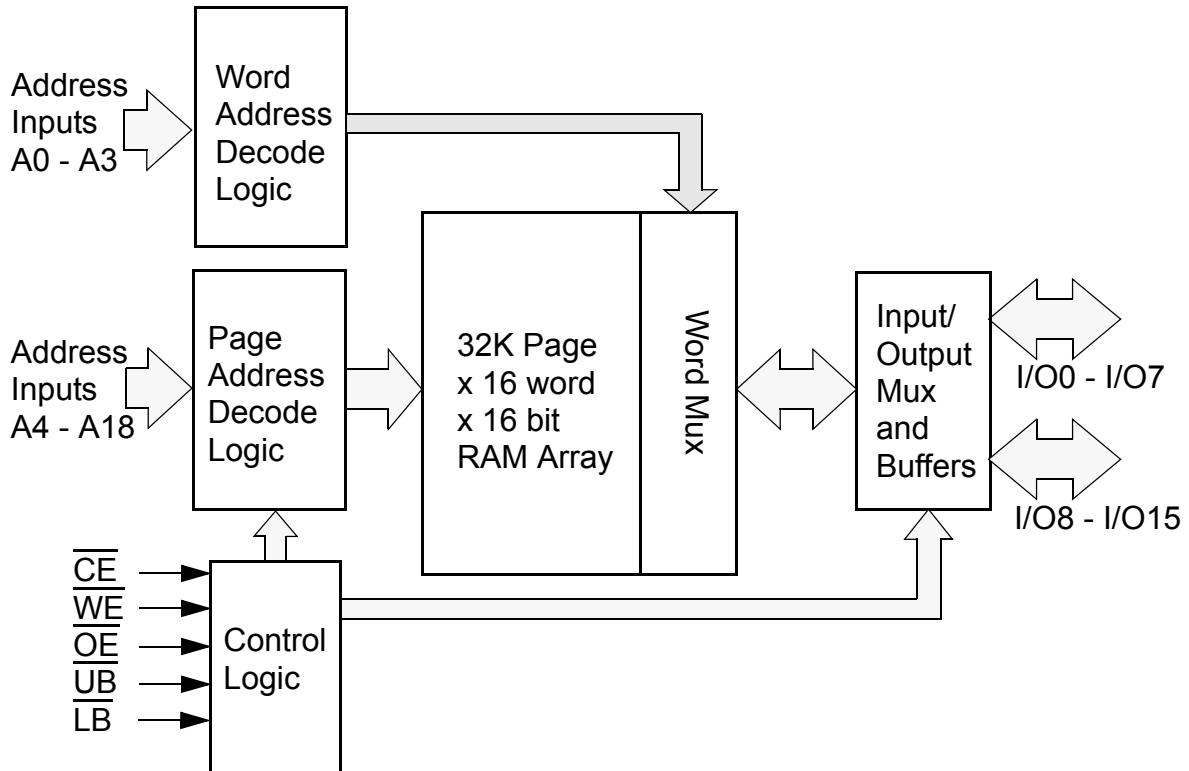

Functional Description

\overline{CE}	\overline{WE}	\overline{OE}	\overline{UB}	\overline{LB}	I/O ₀ - I/O ₁₅ ¹	MODE	POWER
H	X	X	X	X	High Z	Standby ²	Standby
X	X	X	H	H	High Z	Standby ²	Standby
L	L	X ³	L ¹	L ¹	Data In	Write ³	Active
L	H	L	L ¹	L ¹	Data Out	Read	Active
L	H	H	L ¹	L ¹	High Z	Active	Active

1. When \overline{UB} and \overline{LB} are in select mode (low), I/O₀ - I/O₁₅ are affected as shown. When \overline{LB} only is in the select mode only I/O₀ - I/O₇ are affected as shown. When \overline{UB} is in the select mode only I/O₈ - I/O₁₅ are affected as shown.

2. When the device is in standby mode, control inputs (\overline{WE} , \overline{OE} , \overline{UB} , and \overline{LB}), address inputs and data input/outputs are internally isolated from any external influence and disabled from exerting any influence externally.

3. When \overline{WE} is invoked, the \overline{OE} input is internally disabled and has no effect on the circuit.

Capacitance¹

Item	Symbol	Test Condition	Min	Max	Unit
Input Capacitance	C _{IN}	V _{IN} = 0V, f = 1 MHz, T _A = 25°C		10	pF
I/O Capacitance	C _{I/O}	V _{IN} = 0V, f = 1 MHz, T _A = 25°C		10	pF

1. These parameters are verified in device characterization and are not 100% tested

Absolute Maximum Ratings

Item	Symbol	Rating	Unit
Voltage on any pin relative to V_{SS}	$V_{IN,OUT}$	-0.3 to $V_{CC}+0.3$	V
Voltage on V_{CC} Supply Relative to V_{SS}	V_{CC}	-0.3 to 4.5	V
Power Dissipation	P_D	500	mW
Storage Temperature	T_{STG}	-65 to 150	°C
Operating Temperature	T_A	-40 to +85	°C
Soldering Temperature and Time	T_{SOLDER}	260°C, 10sec	°C

Stresses greater than those listed above may cause permanent damage to the device. This is a stress rating only and functional operation of the device at these or any other conditions above those indicated in the operating section of this specification is not implied. Exposure to absolute maximum rating conditions for extended periods may affect reliability.

Operating Characteristics (Over Specified Temperature Range)

Item	Symbol	Test Conditions	Min.	Typ ¹	Max	Unit	
Supply Voltage	V_{CC}		2.2	3.0	3.6	V	
Data Retention Voltage	V_{DR}	Chip Disabled	1.5			V	
Input High Voltage	V_{IH}	$V_{CC} = 2.2V$ to $2.7V$	1.8		$V_{CC}+0.3$	V	
		$V_{CC} = 2.2V$ to $2.7V$	2.2		$V_{CC}+0.3$		
Input Low Voltage	V_{IL}	$V_{CC} = 2.2V$ to $2.7V$	-0.3		0.6	V	
		$V_{CC} = 2.2V$ to $2.7V$	-0.3		0.8		
Output High Voltage	V_{OH}	$I_{OH} = -0.1mA$, $V_{CC} = 2.2V$	2.0			V	
		$I_{OH} = -1.0mA$, $V_{CC} = 2.7V$	2.4				
Output Low Voltage	V_{OL}	$I_{OL} = 0.1mA$, $V_{CC} = 2.2V$			0.4	V	
		$I_{OL} = 2.1mA$, $V_{CC} = 2.2V$			0.4		
Input Leakage Current	I_{LI}	$V_{IN} = 0$ to V_{CC}	-1		1	μA	
Output Leakage Current	I_{LO}	$\overline{OE} = V_{IH}$ or Chip Disabled	-1		1	μA	
Read/Write Operating Supply Current @ 1 μs Cycle Time ²	I_{CC1}	$V_{CC}=3.6V$, $V_{IN}=V_{IH}$ or V_{IL} Chip Enabled, $I_{OUT} = 0$			1.5	3.0	mA
			-L		1.5	3.0	
Read/Write Operating Supply Current @ fmax	I_{CC2}	$V_{CC}=3.6V$, $V_{IN}=V_{IH}$ or V_{IL} Chip Enabled, $I_{OUT} = 0$			12.0	20.0	mA
			-L		12.0	15.0	
Maximum Standby Current	I_{SB1}	$V_{IN} = V_{CC}$ or $0V$ Chip Disabled $t_A = 85^\circ C$, $V_{CC} = 3.6V$			2.0	20	μA
			-L		2.0	8	
Maximum Data Retention Current	I_{DR}	$V_{CC} = 1.5V$, $CE \geq V_{CC} - 0.2V$, $V_{IN} \geq V_{CC} - 0.2V$ or $V_{IN} \leq 0.2V$				10	μA
			-L			4	

1. Typical values are measured at $V_{CC}=V_{CC}$ Typ., $T_A=25^\circ C$ and not 100% tested.

2. This parameter is specified with the outputs disabled to avoid external loading effects. The user must add current required to drive output capacitance expected in the actual system.

Timing Test Conditions

Item	
Input Pulse Level	$0.1V_{CC}$ to $0.9V_{CC}$
Input Rise and Fall Time	1V/ns
Input and Output Timing Reference Levels	$0.5V_{CC}$
Output Load	CL = 50pF
Operating Temperature	-40 to +85 °C

Timing

Item	Symbol	55		Units
		Min	Max	
Read Cycle Time	t_{RC}	55		ns
Address Access Time (Random Access)	t_{AA}		55	ns
Chip Enable to Valid Output	t_{CO}		55	ns
Output Enable to Valid Output	t_{OE}		25	ns
Byte Select to Valid Output	t_{LB}, t_{UB}		55	ns
Chip Enable to Low-Z output	t_{LZ}	10		ns
Output Enable to Low-Z Output	t_{OLZ}	5		ns
Byte Select to Low-Z Output	t_{LBZ}, t_{UBZ}	10		ns
Chip Disable to High-Z Output	t_{HZ}		20	ns
Output Disable to High-Z Output	t_{OHZ}		20	ns
Byte Select Disable to High-Z Output	t_{LBHZ}, t_{UBHZ}		20	ns
Output Hold from Address Change	t_{OH}	10		ns
Write Cycle Time	t_{WC}	55		ns
Chip Enable to End of Write	t_{CW}	40		ns
Address Valid to End of Write	t_{AW}	40		ns
Byte Select to End of Write	t_{LBW}, t_{UBW}	40		ns
Write Pulse Width	t_{WP}	40		ns
Address Setup Time	t_{AS}	0		ns
Write Recovery Time	t_{WR}	0		ns
Write to High-Z Output	t_{WHZ}		20	ns
Data to Write Time Overlap	t_{DW}	25		ns
Data Hold from Write Time	t_{DH}	0		ns
End Write to Low-Z Output	t_{OW}	10		ns

Note:

1. Full device AC operation assumes a 100us ramp time from 0 to $V_{CC}(\min)$ and 200us wait time after V_{CC} stabilization.
2. Full device operation requires linear V_{CC} ramp from V_{DR} to $V_{CC}(\min) \geq 100\text{us}$ or stable at $V_{CC}(\min) \geq 100\text{us}$.

Timing of Read Cycle ($\overline{CE} = \overline{OE} = V_{IL}, \overline{WE} = V_{IH}$)

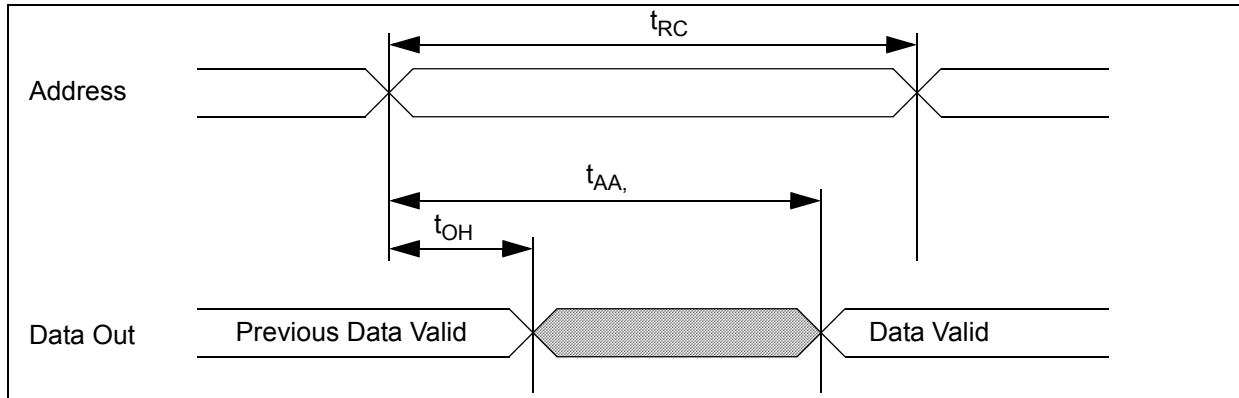

Timing Waveform of Read Cycle ($\overline{WE} = V_{IH}$)

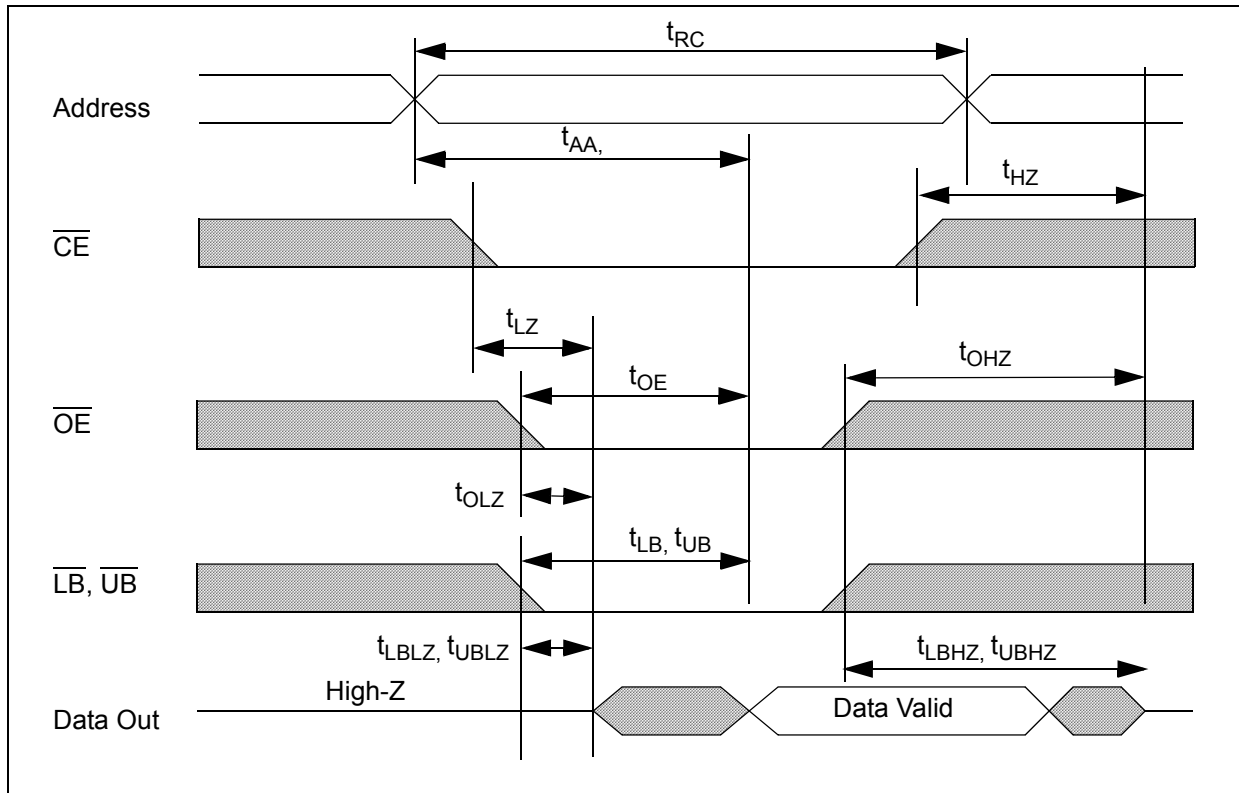

Timing Waveform of Write Cycle (\overline{WE} control)

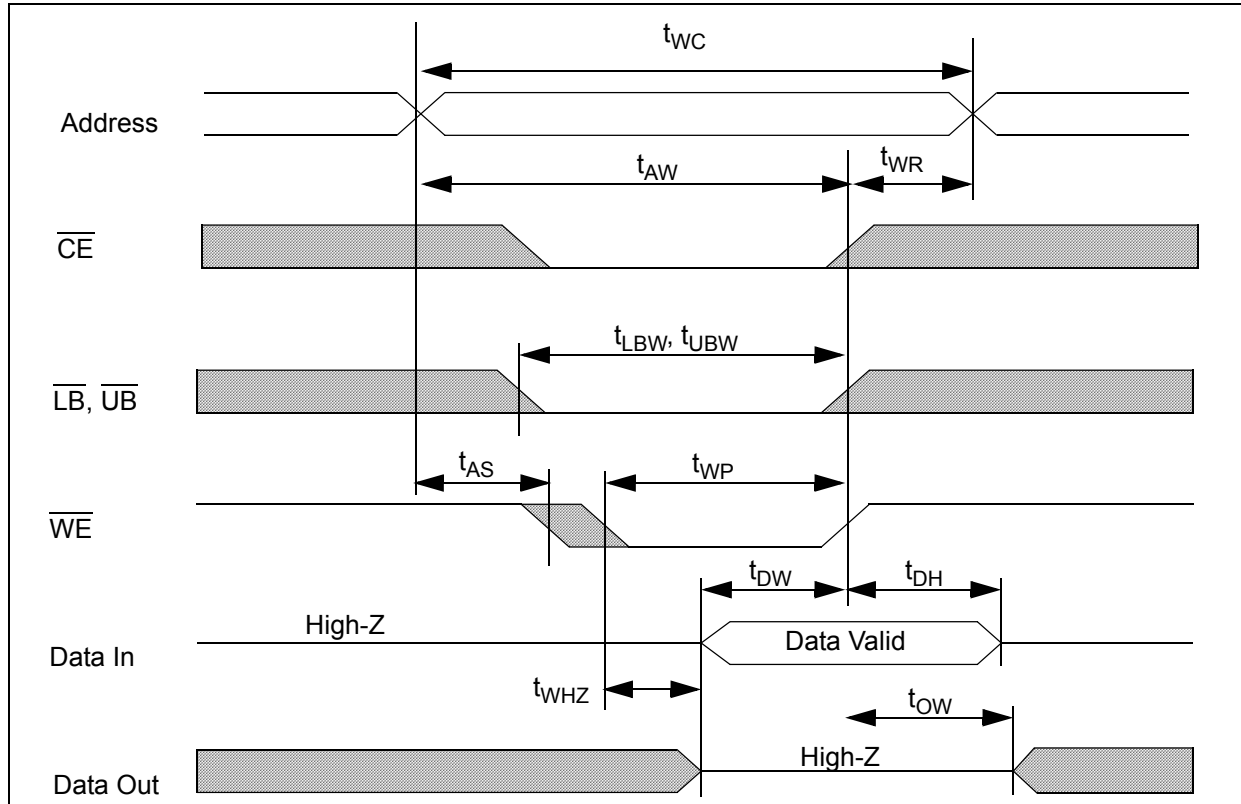

Timing Waveform of Write Cycle (\overline{CE} Control)

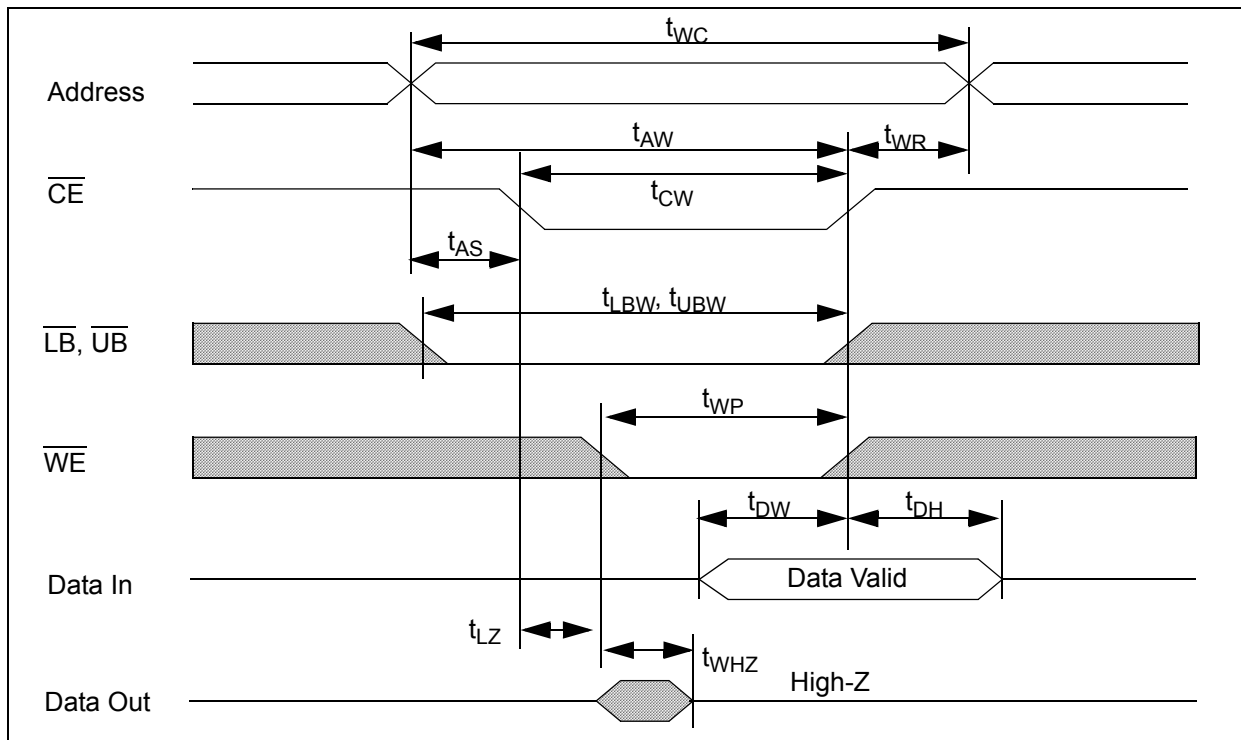

Data Retention Characteristics

Parameter	Description	Condition	Min	Typ	Max	Unit
V_{DR}	Vcc for Data Retention		1.5			V
I_{CCDR}	Data Retention Current	$V_{CC} = 1.5V, CE \geq V_{CC} - 0.2V,$ $V_{IN} \geq V_{CC} - 0.2V$ or $V_{IN} \leq 0.2V$			10 4	μA
t_{CDR}	Chip Deselect to Data Retention Time		0			ns
t_R	Operation Recovery Time		t_{RC}			ns

Data Retention Waveform

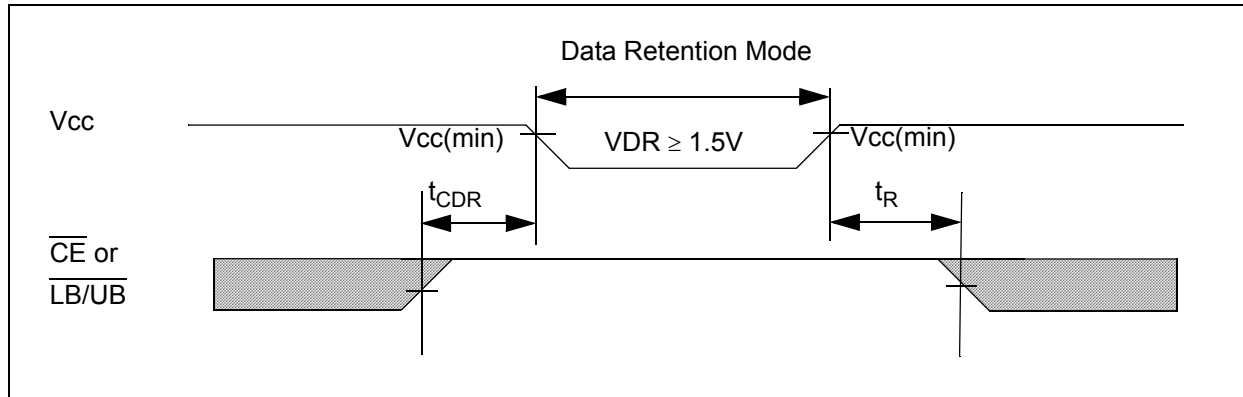

Note: Full device operation requires linear V_{CC} ramp from V_{DR} to $V_{CC(min)}$ > 100 μs

44 TSOP II Package (ZS44)

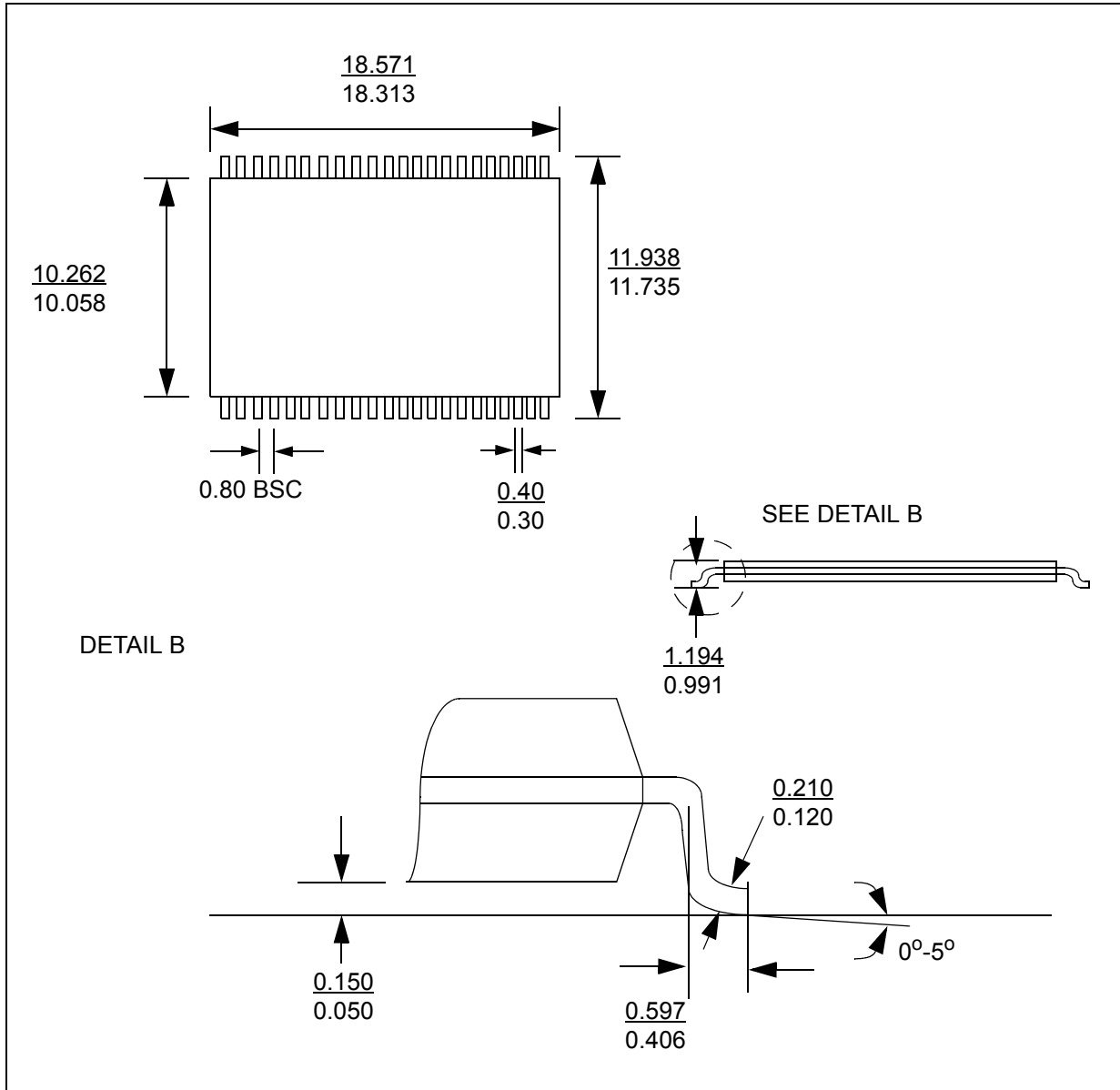

Ordering Information

N08L163WC1CX-XX X L

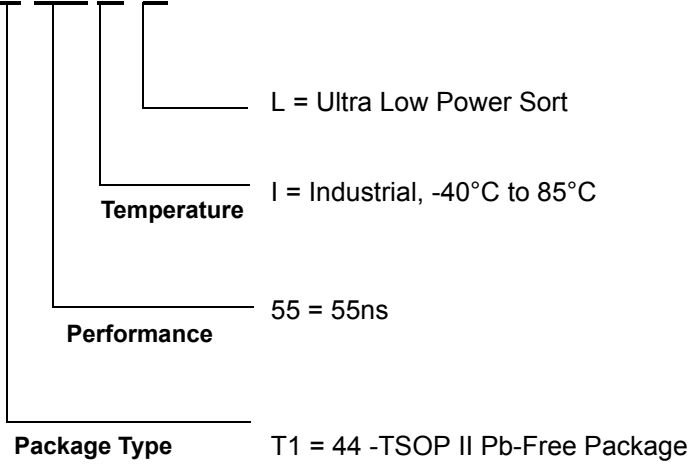

Revision History

Revision	Date	Change Description
A	Nov 9. 2004	Initial Advance Release
B	Jan 14. 2005	General Update Released Under Document Control

© 2001 - 2002 Nanoamp Solutions, Inc. All rights reserved.

NanoAmp Solutions, Inc. ("NanoAmp") reserves the right to change or modify the information contained in this data sheet and the products described therein, without prior notice. NanoAmp does not convey any license under its patent rights nor the rights of others. Charts, drawings and schedules contained in this data sheet are provided for illustration purposes only and they vary depending upon specific applications.

NanoAmp makes no warranty or guarantee regarding suitability of these products for any particular purpose, nor does NanoAmp assume any liability arising out of the application or use of any product or circuit described herein. NanoAmp does not authorize use of its products as critical components in any application in which the failure of the NanoAmp product may be expected to result in significant injury or death, including life support systems and critical medical instruments.