

2ch VOLTAGE DETECTOR

■ GENERAL DESCRIPTION

The NJU7712/13 is a 2ch low quiescent current voltage detector featuring high precision detection voltage.

The detection voltage is fixed internally with an accuracy of 1.0%.

NJU7712 is Nch. Open Drain and NJU7713 of output circuit form is a C-MOS output.

■ PACKAGE OUTLINE



NJU7712/13F



NJU7712/13F3

■ FEATURES

- High Precision detection Voltage $\pm 1.0\%$
- Low Quiescent Current $0.8\mu\text{A}(\text{per } 1\text{ch})$
- Detection Voltage Range $1.5 \sim 6.0\text{V}(0.1\text{V step})$ It applies only to 1ch(Over Voltage Detect).
 $1.3 \sim 6.0\text{V}(0.1\text{V step})$ It applies only to 2ch(Low Voltage Detect).
- 1ch: Over Voltage Detect, 2ch: Low Voltage Detect
- Output Circuit Form
 NJU7712: Nch. Open Drain Type
 NJU7713: C-MOS Output Type
- CMOS Technology
- Package Outline SOT-23-5 (MTP5) / SC88A

■ PIN CONFIGURATION

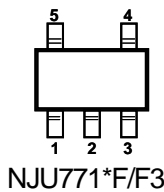

PIN FUNCTION

1. V_{OUT1}
2. V_{SS}
3. V_{DD1}
4. V_{DD2}
5. V_{OUT2}

■ EQUIVALENT CIRCUIT

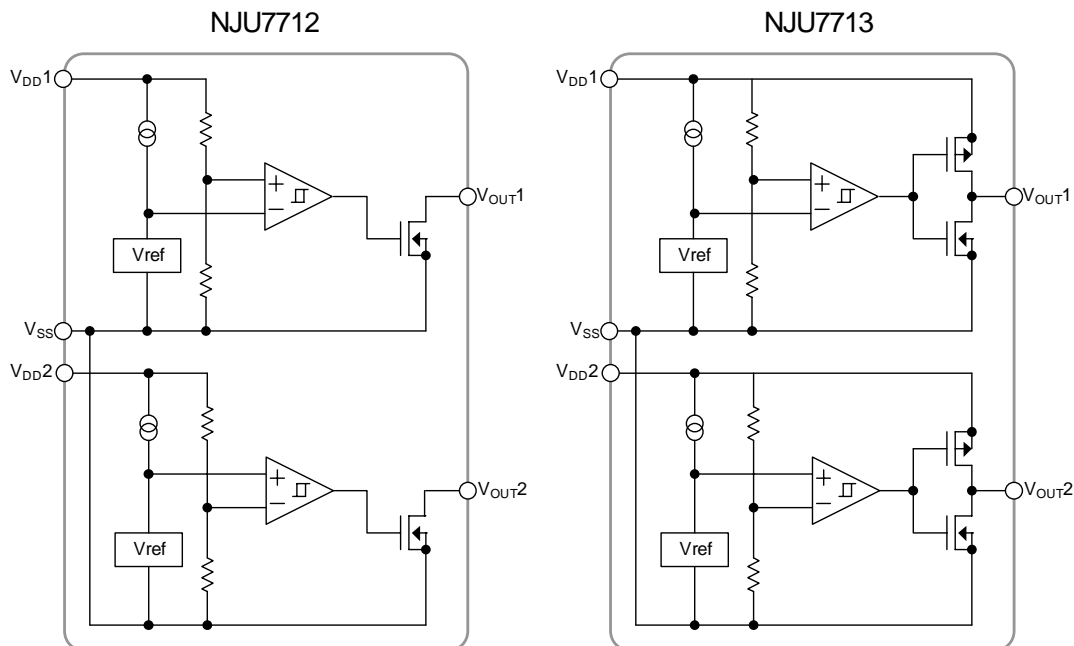

NJU7712/13

■ DETECTION VOLTAGERANK LIST

Device Name	Package	V _{DET}	
		CH1	CH2
NJU7712/13F4227	SOT-23-5 (MTP5)	4.2V	2.7V
NJU7712/13F0613		6.0V	1.3V
NJU7712/13F3-4227	SC88A	4.2V	2.7V
NJU7712/13F3-0613		6.0V	1.3V

■ NJU7712

■ ABSOLUTE MAXIMUM RATINGS (Ta=25°C)

PARAMETER	SYMBOL	RATINGS	UNIT
Input Voltage	V _{DD}	+10	V
Output Voltage	V _{OUT}	V _{SS} -0.3 ~ +10	V
Output Current	I _{OUT}	50	mA
Power Dissipation	P _D	200(MTP5)	mW
		250(SC88A(*note 1))	
Operating Temperature	Topr	-40 ~ +85	°C
Storage Temperature	Tstg	-40 ~ +125	°C

(*note 1): On board, 50mm×50mm×1.6mm glass epoxy baseplate.

■ ELECTRICAL CHARACTERISTICS

(1ch: Over Voltage Detect, Ta=25°C)

PARAMETER	SYMBOL	TEST CONDITION	MIN.	TYP.	MAX.	UNIT	
Detection Voltage	V _{DET1}		-1.0%	–	+1.0%	V	
Hysteresis Voltage	V _{HYS1}		V _{DET} ×0.03	V _{DET} ×0.05	V _{DET} ×0.08	V	
Quiescent Current	I _{SS1}	V _{DD1} =V _{DET1} +1V	V _{DET1} =1.5V ~ 1.7V Version	–	0.5	1.0	μA
			V _{DET1} =1.8V ~ 6.0V Version	–	0.8	1.6	μA
Output Current	I _{OUT1}	Nch, V _{DS1} =0.5V	V _{DD1} =4.8V(≤4.3V Version)	6	13	–	mA
			V _{DD1} =7.0V	8	18	–	mA
Output Leak Current	I _{LEAK1}	V _{DD1} =V _{OUT1} =9V	–	–	0.1	μA	
Detection Voltage Temperature Coefficient	ΔV _{DET1} /ΔTa	Ta=0 ~ +85°C	–	±100	–	ppm/°C	
Operating Voltage (*note 2)	V _{DD1}	R _{L1} =100kΩ	0.8	–	9	V	

(*note 2): The minimum Operating Voltage(V_{OPL}) indicates the same value of the output voltage(V_{OUT}) on condition that V_{OUT} becomes 90% or less of the input voltage(V_{DD}).

(2ch: Low Voltage Detect, Ta=25°C)

PARAMETER	SYMBOL	TEST CONDITION	MIN.	TYP.	MAX.	UNIT	
Detection Voltage	V _{DET2}		-1.0%	–	+1.0%	V	
Hysteresis Voltage	V _{HYS2}		V _{DET} ×0.03	V _{DET} ×0.05	V _{DET} ×0.08	V	
Quiescent Current	I _{SS2}	V _{DD2} =V _{DET2} +1V	V _{DET2} =1.3V ~ 1.7V Version	–	0.5	1.0	μA
			V _{DET2} =1.8V ~ 6.0V Version	–	0.8	1.6	μA
Output Current	I _{OUT2}	Nch, V _{DS2} =0.5V	V _{DD2} =1.2V	0.75	2.0	–	mA
			V _{DD2} =2.4V (≥4.3V Version)	4.5	7.0	–	mA
Output Leak Current	I _{LEAK2}	V _{DD2} =V _{OUT2} =9V	–	–	0.1	μA	
Detection Voltage Temperature Coefficient	ΔV _{DET2} /ΔTa	Ta=0 ~ +85°C	–	±100	–	ppm/°C	
Operating Voltage (*note 3)	V _{DD2}	R _{L2} =100kΩ	0.8	–	9	V	

(*note 3): The minimum Operating Voltage(V_{OPL}) indicates the same value of the output voltage(V_{OUT}) on condition that V_{OUT} becomes 10% or less of the input voltage(V_{DD}).

TEST CIRCUIT

① COMMON TEST CIRCUIT

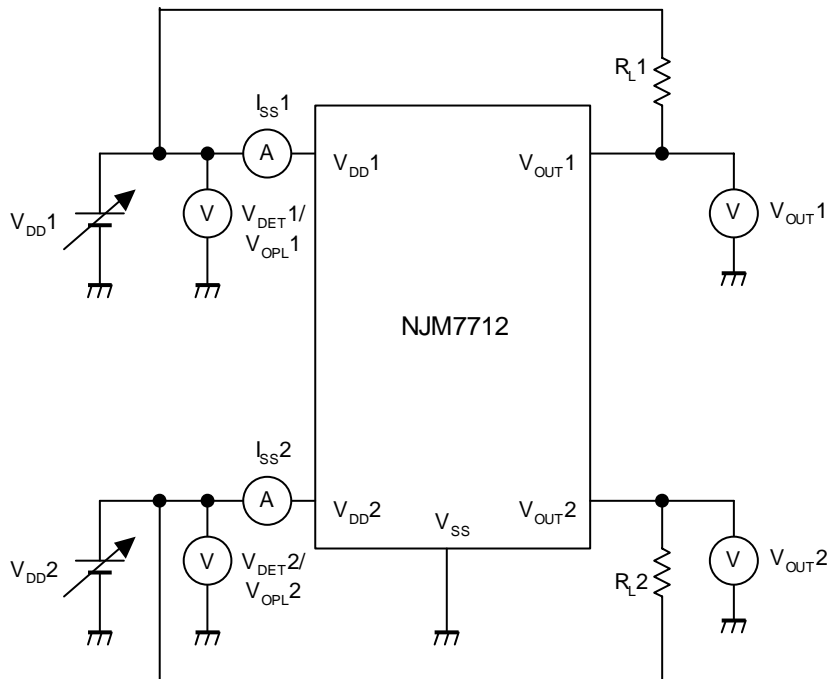

② OUTPUT CURRENT / LEAK CURRENT TEST CIRCUIT

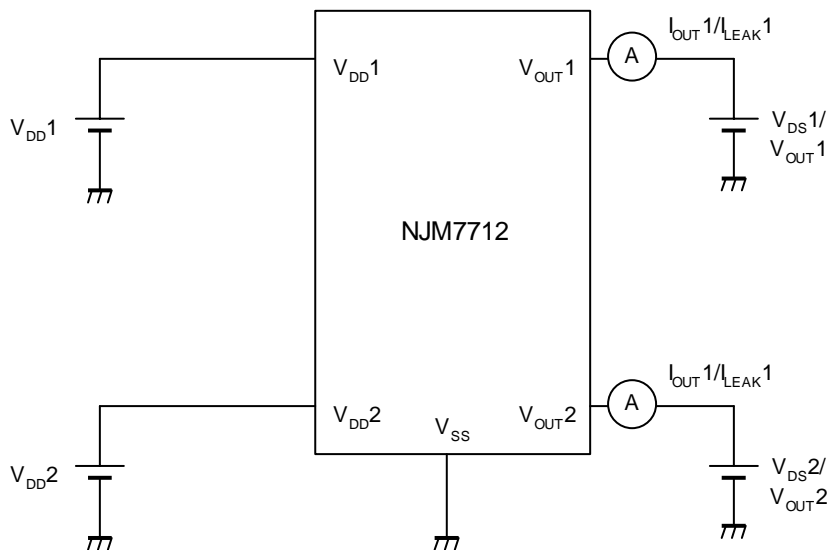

■ TYPICAL APPLICATION

① Battery voltage supervision

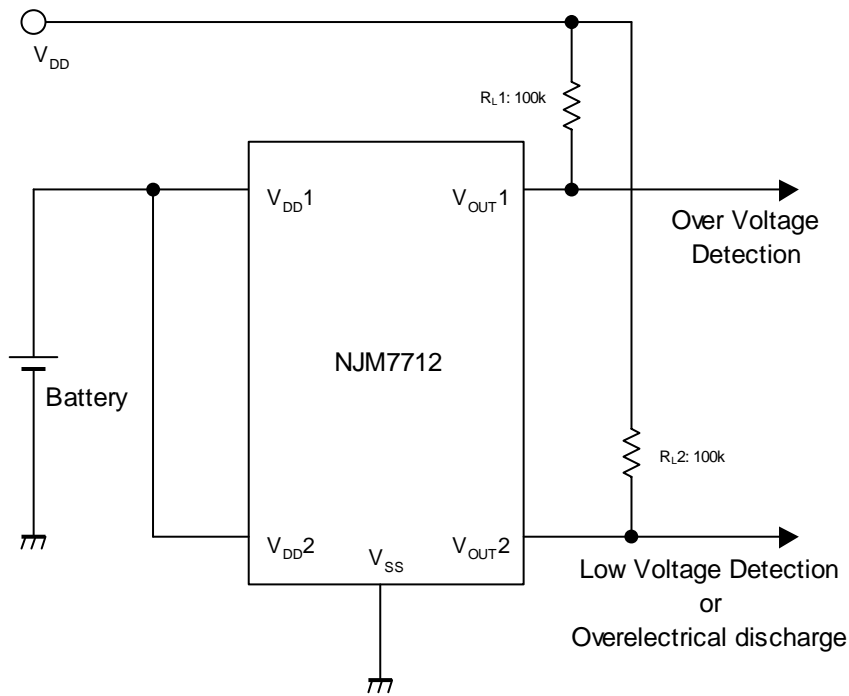

② Window Comparator

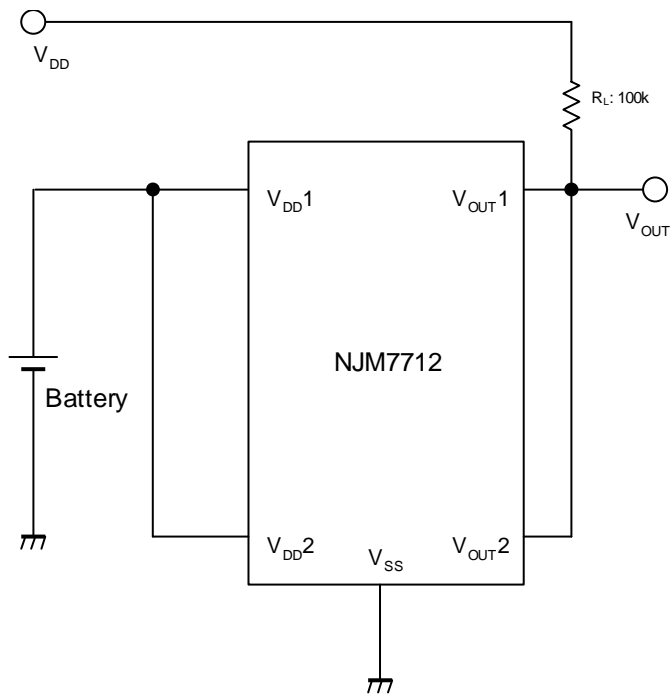

NJU7712/13

■ NJU7713

■ ABSOLUTE MAXIMUM RATINGS

(Ta=25°C)

PARAMETER	SYMBOL	RATINGS	UNIT
Input Voltage	V _{DD}	+10	V
Output Voltage	V _{OUT}	V _{SS} -0.3 ~ +10	V
Output Current	I _{OUT}	50	mA
Power Dissipation	P _D	200(MTP5)	mW
		250(SC88A(*note 1))	
Operating Temperature	Topr	-40 ~ +85	°C
Storage Temperature	Tstg	-40 ~ +125	°C

(*note 1): On board, 50mm×50mm×1.6mm glass epoxy baseplate.

■ ELECTRICAL CHARACTERISTICS

(1ch: Over Voltage Detect, Ta=25°C)

PARAMETER	SYMBOL	TEST CONDITION	MIN.	TYP.	MAX.	UNIT	
Detection Voltage	V _{DET1}		-1.0%	-	+1.0%	V	
Hysterisis Voltage	V _{HYS1}		V _{DET} x0.03	V _{DET} x0.05	V _{DET} x0.08	V	
Quiescent Current	I _{SS1}	V _{DD1} =V _{DET1} +1V	V _{DET1} =1.5V ~ 1.7V Version	-	0.5	1.0	μA
			V _{DET1} =1.8V ~ 6.0V Version	-	0.8	1.6	μA
Output Current	I _{OUT1}	Nch, V _{DS1} =0.5V	V _{DD1} =4.8V(≤4.3V Version)	6	13	-	mA
			V _{DD1} =7.0V	8	18	-	mA
		Pch, V _{DS1} =0.5V	V _{DD1} =1.4V	0.1	0.4	-	mA
			V _{DD1} =2.4V(≥2.7V Version)	0.6	1.6	-	mA
Detection Voltage Temperature Coefficient	ΔV _{DET1} /ΔTa	Ta=0 ~ +85°C	-	±100	-	ppm/°C	
Operating Voltage (*note 4)	V _{DD1}	R _{L1} =100kΩ	1.2	-	9	V	

(*note 4): The minimum Operating Voltage(V_{OPL}) indicates the same value of the output voltage(V_{OUT}) on condition that V_{OUT} becomes 90% or less of the input voltage(V_{DD}).

(2ch: Low Voltage detect, Ta=25°C)

PARAMETER	SYMBOL	TEST CONDITION	MIN.	TYP.	MAX.	UNIT	
Detection Voltage	V _{DET2}		-1.0%	-	+1.0%	V	
Hysterisis Voltage	V _{HYS2}		V _{DET} x0.03	V _{DET} x0.05	V _{DET} x0.08	V	
Quiescent Current	I _{SS2}	V _{DD2} =V _{DET2} +1V	V _{DET2} =1.5V ~ 1.7V Version	-	0.5	1.0	μA
			V _{DET2} =1.8V ~ 6.0V Version	-	0.8	1.6	μA
Output Current	I _{OUT2}	Nch, V _{DS2} =0.5V	V _{DD2} =4.8V(≤4.3V Version)	0.75	2.0	-	mA
			V _{DD2} =7.0V	4.5	7.0	-	mA
			V _{DD2} =1.4V	2.0	3.5	-	mA
		Pch, V _{DS2} =0.5V	V _{DD2} =2.4V (4.0V~5.6V Version)	2.5	4.0	-	mA
			V _{DD2} =8.4V (≥5.7V Version)	3.0	5.0	-	mA
Detection Voltage Temperature Coefficient	ΔV _{DET2} /ΔTa	Ta=0 ~ +85°C	-	±100	-	ppm/°C	
Operating Voltage (*note 5)	V _{DD2}	R _{L2} =100kΩ	0.8	-	9	V	

(*note 5): The minimum Operating Voltage(V_{OPL}) indicates the same value of the output voltage(V_{OUT}) on condition that V_{OUT} becomes 10% or less of the input voltage(V_{DD}).

■ TEST CIRCUIT

① COMMON TEST CIRCUIT

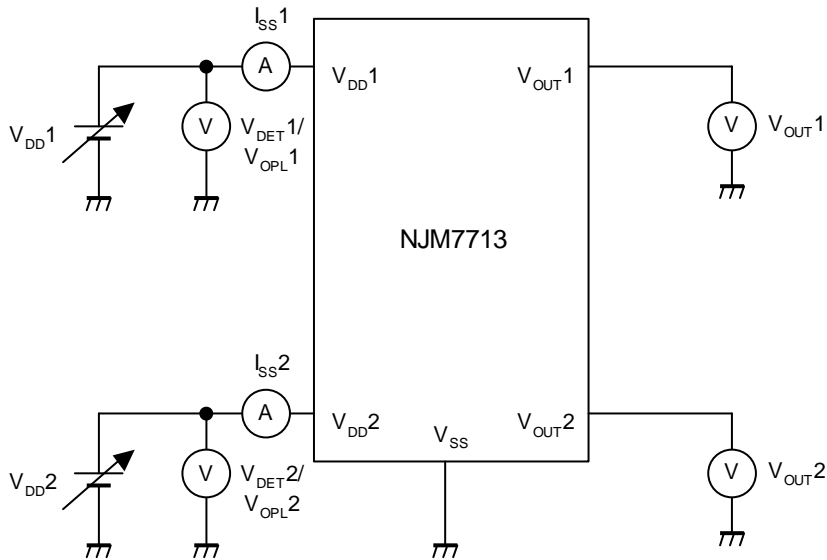

② Nch OUTPUT CURRENT TEST CIRCUIT

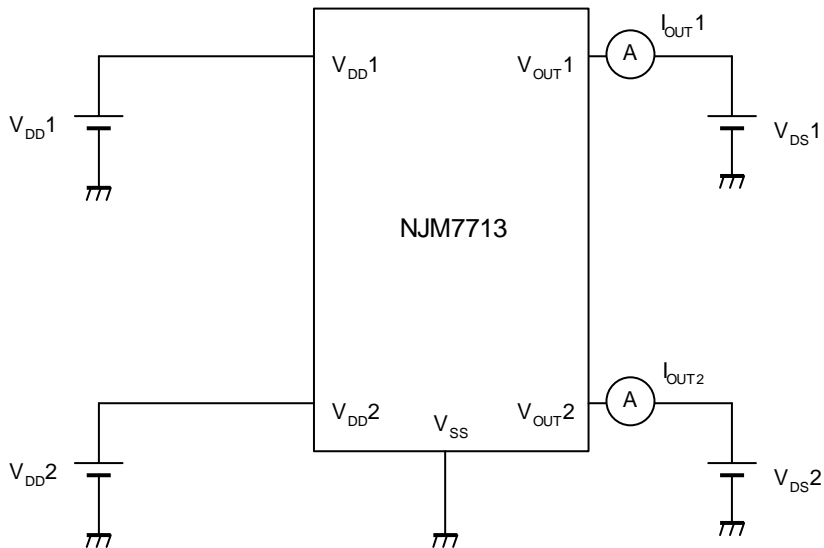

③ Pch OUTPUT CURRENT TEST CIRCUIT

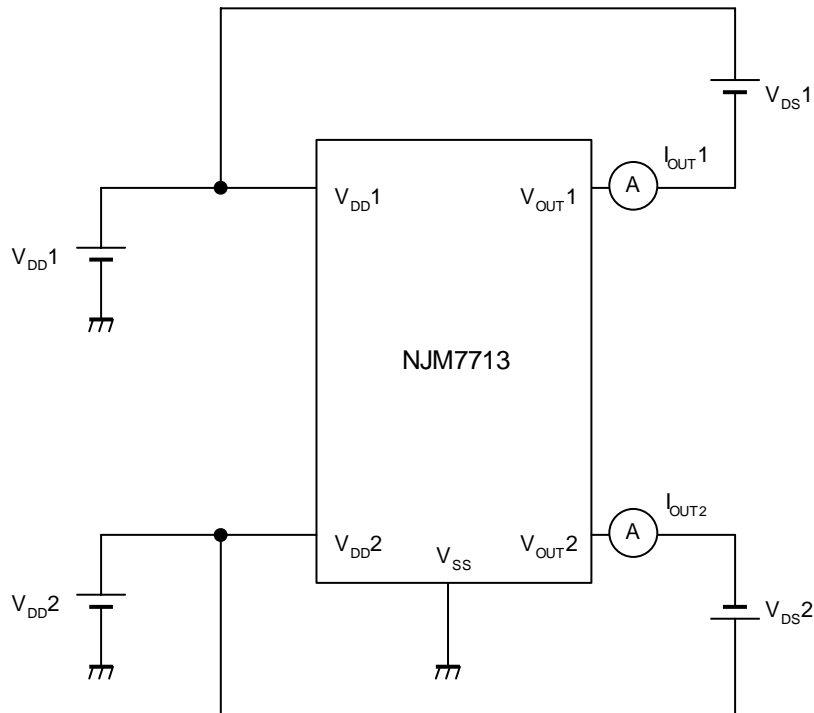

④ MINIMUM OPERATING VOLTAGE TEST CIRCUIT

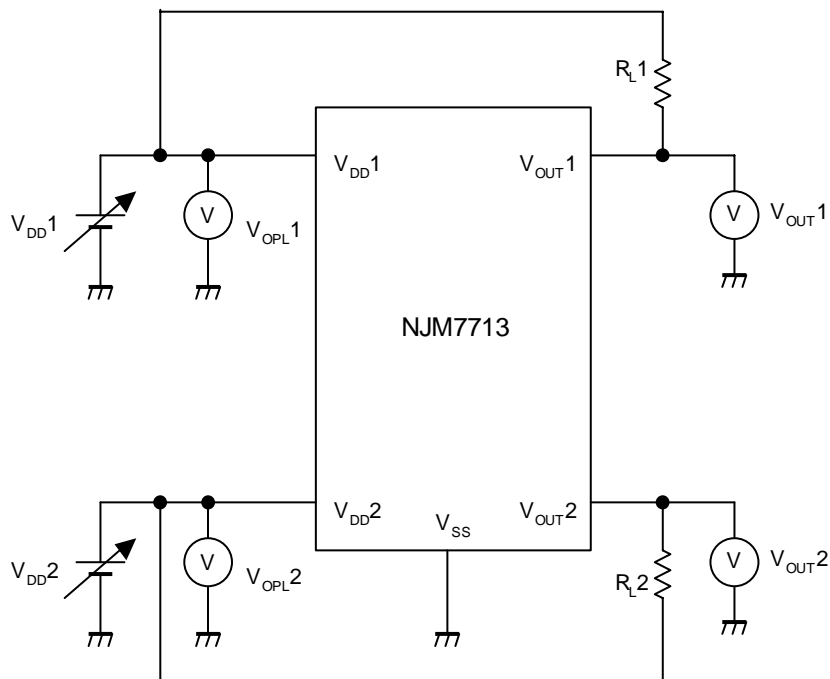

■ TYPICAL APPLICATION

① Battery voltage supervision

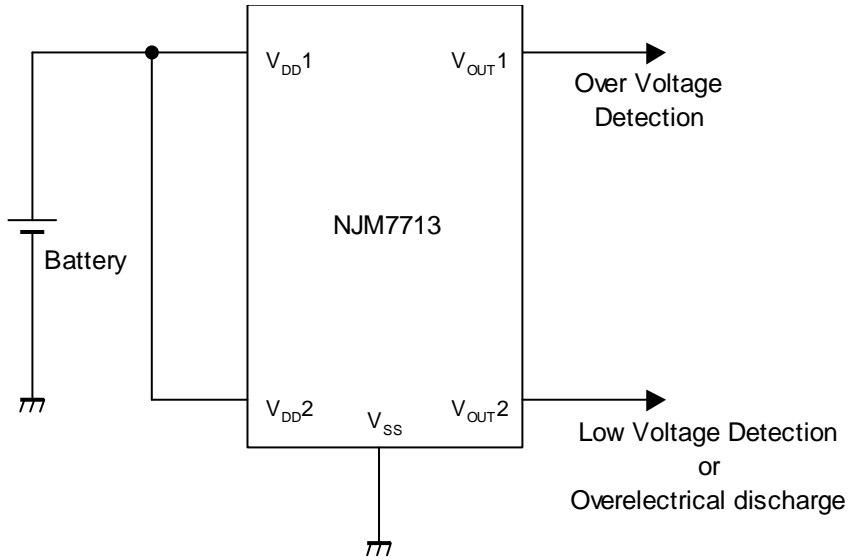

[CAUTION]

The specifications on this databook are only given for information, without any guarantee as regards either mistakes or omissions. The application circuits in this databook are described only to show representative usages of the product and not intended for the guarantee or permission of any right including the industrial rights.