

2.5 GHz InGaP HBT 5W Linear Power Amplifier

May 2006 - Rev 24-May-06

CHV2710-QJ
RoHS

Features

- ✕ Internal Pre-matching
- ✕ Single Supply operation
- ✕ Power Gain - 9.5dB
- ✕ Intermodulation Distortion - -30dBc @ 34dBm per tone
- ✕ ESD Protection on board
- ✕ Current Control for multiple applications
- ✕ 2.5% EVM @ 30dBm avg power, 802.16 OFDM signal format, PAR=9.5dB
- ✕ Plastic Surface mount packaging
- ✕ Low Thermal Resistance
- ✕ Ideal for WiMAX applications
- ✕ Lead Free and RoHS compliant 6x6 QFN package
- ✕ Evaluation Boards Available

Functional Block Diagram

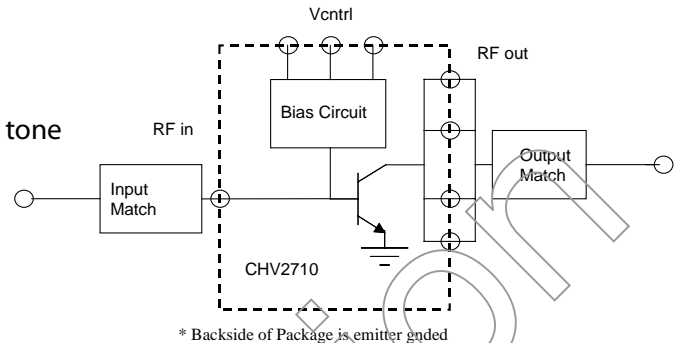

General Description

The CHV2710 internally pre-matched power HBT device provides 9.5dB of gain, 2.5% EVM at 30dBm output power for 802.16 OFDM signal with a peak to average power ratio of 9.5dB. The device operates off a single supply voltage up to 12V and includes internal bias circuitry to enable exact setting of the quiescent current using an external Vcontrol. This Vcontrol is non-unique voltage setting and the same value can be used for each part depending on the required Icq. The device is ideal for high linearity, high data rate applications such as WiMAX. Internal pre-matching facilitates a simplified external matching approach and the highest in-band gain potential of the device. The device operates with unique matching at each of the popular WiMAX bands with the inherent repeatability of an InGaP HBT process.

Absolute Maximum Ratings

PARAMETER	RATING	
	MIN	MAX
Voltage supply (Vcc)	4.5 V	12 V
Current (Icc)	-	2000 mA
Dissipated power (Pdiss)	-	18 W
Input power (Pin)	-	30 dBm
Storage temperature (Tstg)	-60 C	150 C
Channel temperature (Tch)	-	175 C
Operating backside temperature (Tb)	-40 C	(³)

(²) Operation outside any of these limits can cause permanent damage.

(³) Calculate maximum operating temperature Tmax using the following formula:
Tmax=175-(Pdiss [W] x 5) [C].

Room temperature. Typical bias conditions: Vcc=12V. Typical assembly.⁽¹⁾

PARAMETER	SYMBOL	MIN	TYP	MAX	UNITS
Operating frequency band	F		2.5		GHz
Quiescent current (depends on Vcc)	Icq		730	760	mA
Power gain at 30 dBm power	Gps		11		dB
Collector Current at 30 dBm	Icc		775	800	mA
Output third order distortion point at 34dBm per tone power, f1=2650 MHz, f2=2650.1MHz	IMD		-31	-30	dBc
Output third order distortion point at 30dBm per tone power, f1=2650 MHz, f2=2650.1MHz	IMD		-41	-40	dBc
Input reflection coefficient at 2700 MHz	IRL	-	-16.0	-10.0	dB
Pout with 2.5% EVM under 802.16d OFDM signal format with PAR = 9.5dB	Po_2.5%E VM_9.5	29.0	30.0		dBm
Thermal resistance	Rth	-	-	5	C/W
Noise figure at 2.65GHz	NF	-	4.5	-	dB

(¹) Data measured in a Celeritek matched connectorized fixture.

2.5 GHz InGaP HBT 5W Linear Power Amplifier

May 2006 - Rev 24-May-06

CHV2710-Q
RoHS

Typical Performance: ($V_{cc} = 12V$, $V_{control} = 8V$, $I_{cc} = 736mA$)

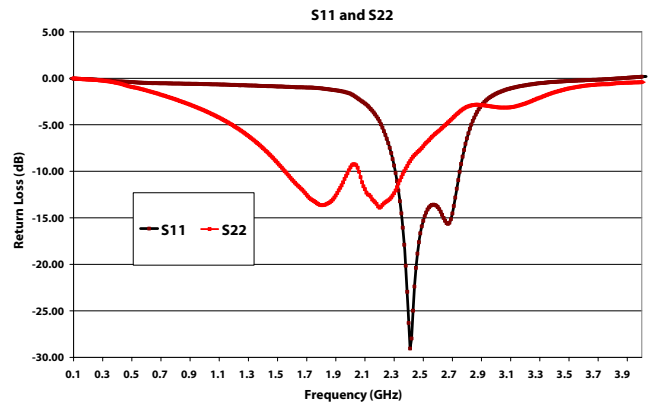
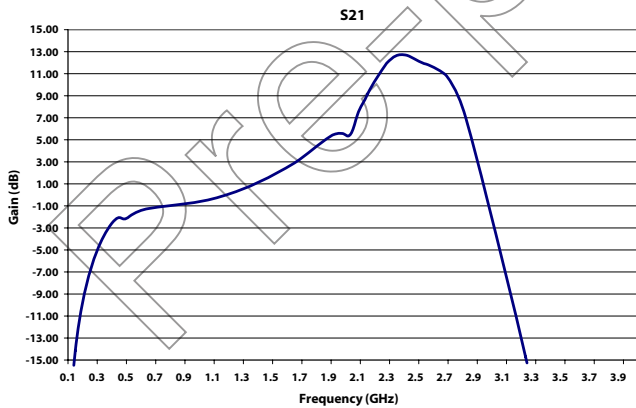
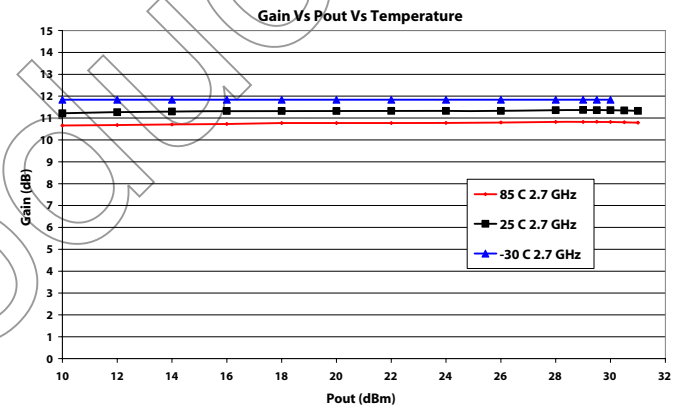
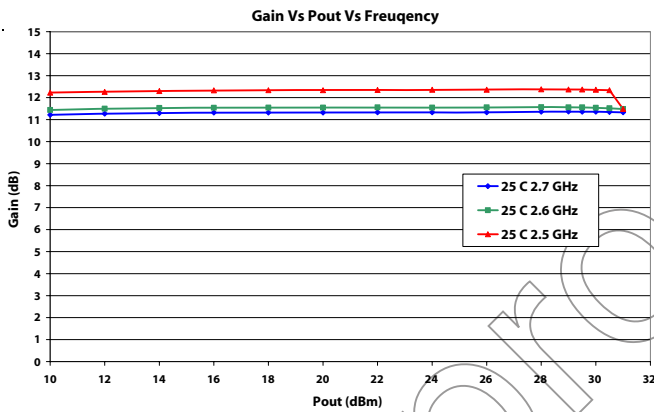
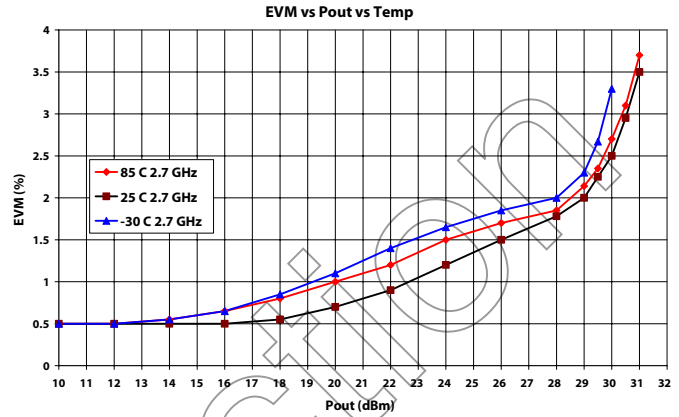
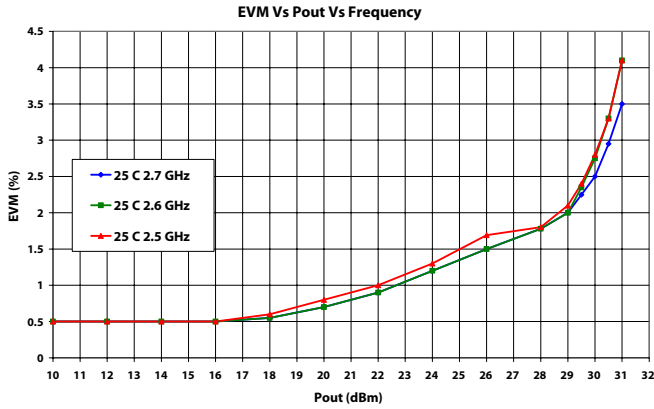

2.5 GHz InGaP HBT 5W Linear Power Amplifier

Recommended Board Schematic

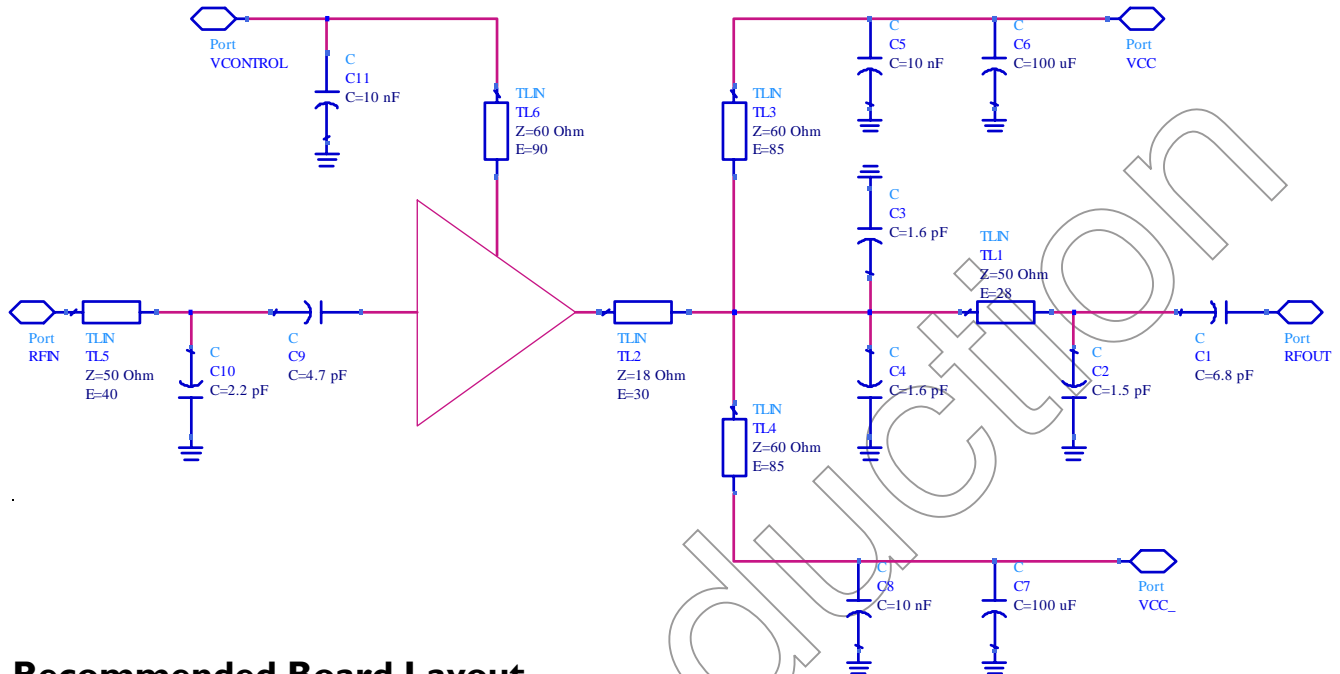

Recommended Board Layout

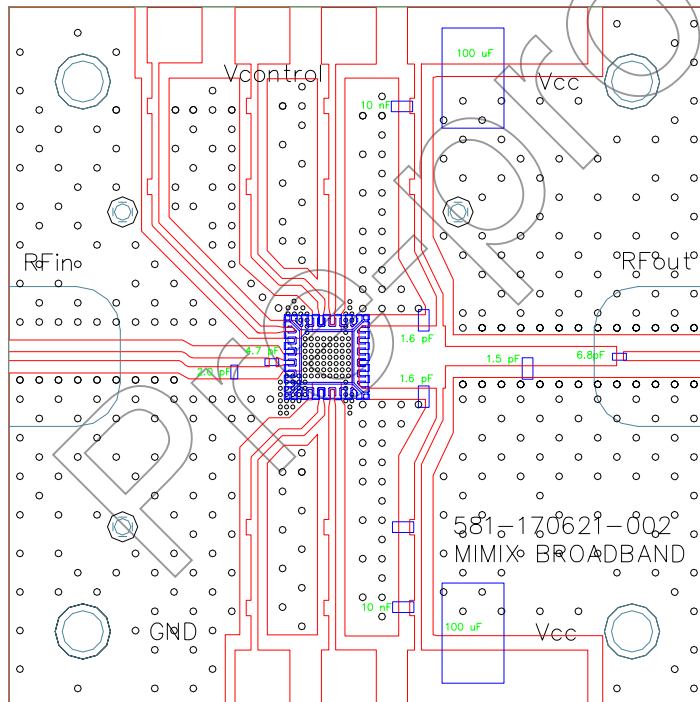

12 mil RO4003

2.5 GHz InGaP HBT 5W Linear Power Amplifier

May 2006 - Rev 24-May-06

Mimix
BROADBAND™

CHV2710-Q
RoHS

Recommended Board Layout:

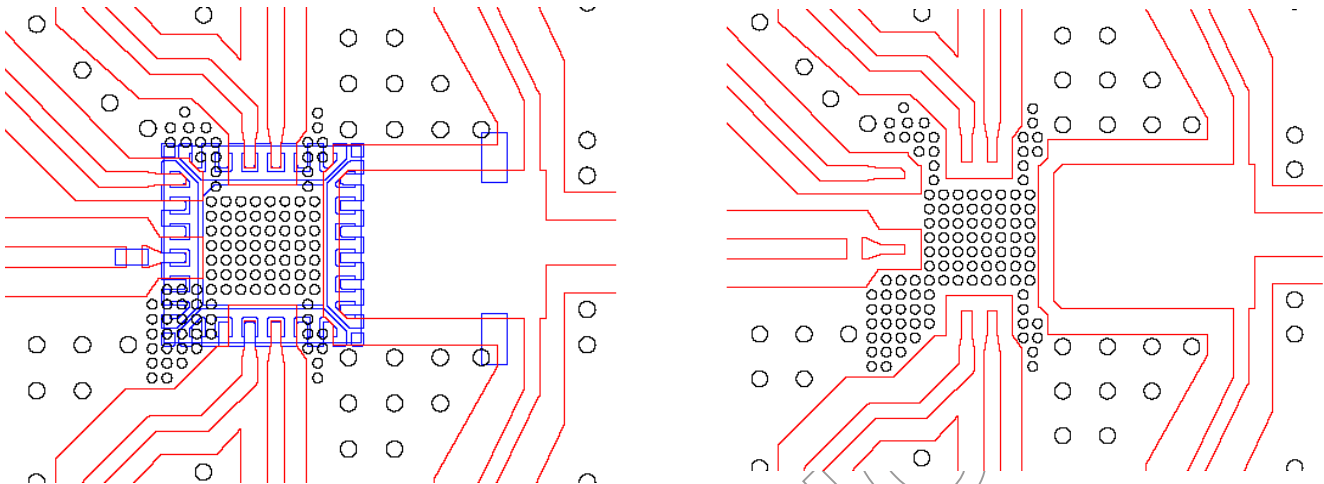

We recommend that all N/C pins be grounded and sufficient number of vias to be present under the ground plane. Pins 13 and 18 are connected to the R_{Fout} trace.

Physical Dimensions:

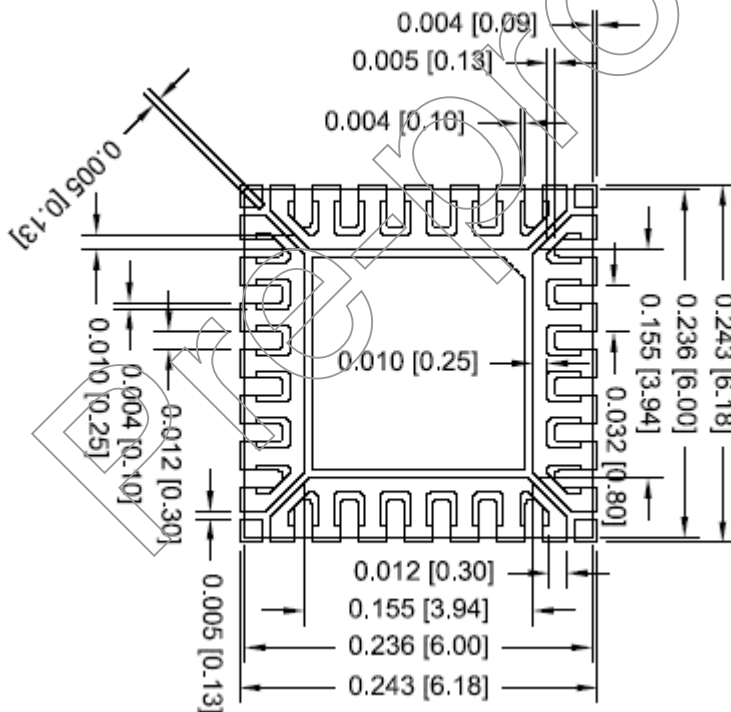

Mimix Broadband, Inc., 10795 Rockley Rd., Houston, Texas 77099
Tel: 281.988.4600 Fax: 281.988.4615 mimixbroadband.com

Page 4 of 6

Characteristic Data and Specifications are subject to change without notice. ©2006 Mimix Broadband, Inc.
Export of this item may require appropriate export licensing from the U.S. Government. In purchasing these parts, U.S. Domestic customers accept their obligation to be compliant with U.S. Export Laws.

2.5 GHz InGaP HBT 5W Linear Power Amplifier

May 2006 - Rev 24-May-06

Mimix
BROADBAND™

CHV2710-QJ
RoHS

Pin Assignment:

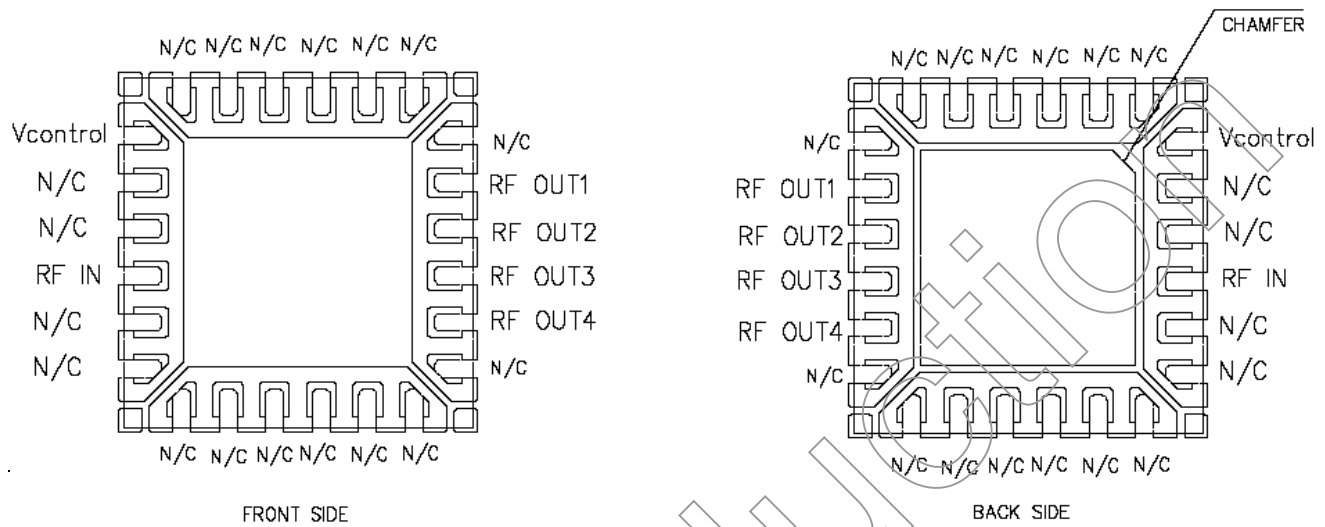

Functional Block Diagram:

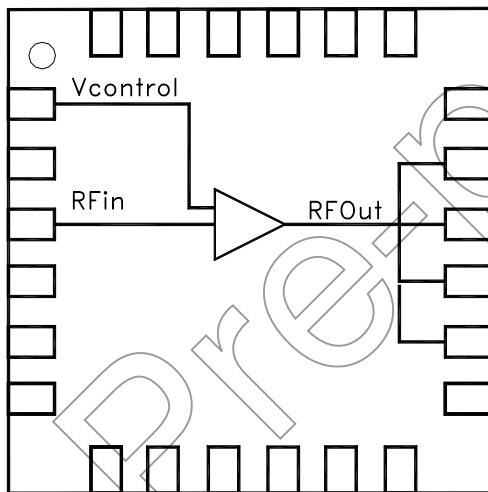

Pin #	Description
1	Vcontrol
4	RF IN
14	RF OUT 4
15	RF OUT 3
16	RF OUT 2
17	RF OUT 1
2, 3, 5, 6, 7, 8, 9, 10, 11, 12 13, 18, 19, 20, 21, 22, 23, 24	N/C

2.5 GHz InGaP HBT 5W Linear Power Amplifier

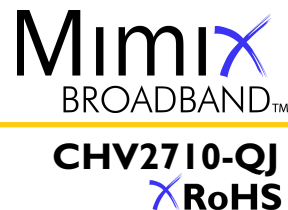

May 2006 - Rev 24-May-06

Handling and Assembly Information

CAUTION! - Mimix Broadband MMIC Products contain gallium arsenide (GaAs) which can be hazardous to the human body and the environment. For safety, observe the following procedures:

- Do not ingest.
- Do not alter the form of this product into a gas, powder, or liquid through burning, crushing, or chemical processing as these by-products are dangerous to the human body if inhaled, ingested, or swallowed.
- Observe government laws and company regulations when discarding this product. This product must be discarded in accordance with methods specified by applicable hazardous waste procedures.

Life Support Policy - Mimix Broadband's products are not authorized for use as critical components in life support devices or systems without the express written approval of the President and General Counsel of Mimix Broadband. As used herein: (1) Life support devices or systems are devices or systems which, (a) are intended for surgical implant into the body, or (b) support or sustain life, and whose failure to perform when properly used in accordance with instructions for use provided in the labeling, can be reasonably expected to result in a significant injury to the user. (2) A critical component is any component of a life support device or system whose failure to perform can be reasonably expected to cause the failure of the life support device or system, or to affect its safety or effectiveness.

ESD - Gallium Arsenide (GaAs) devices are susceptible to electrostatic and mechanical damage. Die are supplied in antistatic containers, which should be opened in cleanroom conditions at an appropriately grounded anti-static workstation. Devices need careful handling using correctly designed collets, vacuum pickups or, with care, sharp tweezers.

Mimix Lead-Free RoHS Compliant Program - Mimix has an active program in place to meet customer and governmental requirements for eliminating lead (Pb) and other environmentally hazardous materials from our products. All Mimix RoHS compliant components are form, fit and functional replacements for their non-RoHS equivalents. Lead plating of our RoHS compliant parts is 100% matt tin (Sn) over copper alloy and is backwards compatible with current standard SnPb low-temperature reflow processes as well as higher temperature (260°C reflow) "Pb Free" processes.

For those customers not making the change at this time, Mimix will maintain production of current configurations. For questions and comments e-mail: ourearth@mimixbroadband.com.

Ordering Information

Part Number for Ordering

CHV2710-QJ-0G00
CHV2710-QJ-0G0T
PB-CHV2710-0000

Package

Matte Tin plated RoHS compliant 6X6 QFN surface mount package in bulk
Matte Tin Plated RoHS compliant 6X6 QFN surface mount package in tape and reel
Evaluation Board with SMA connectors

We also offer the plastic package with SnPb (Tin-Lead) or NiPdAu plating. Please contact your regional sales manager for more information regarding different plating types.

Mimix Broadband, Inc., 10795 Rockley Rd., Houston, Texas 77099
Tel: 281.988.4600 Fax: 281.988.4615 mimixbroadband.com

Page 6 of 6

Characteristic Data and Specifications are subject to change without notice. ©2006 Mimix Broadband, Inc.
Export of this item may require appropriate export licensing from the U.S. Government. In purchasing these parts, U.S. Domestic customers accept their obligation to be compliant with U.S. Export Laws.