

DATA SHEET



PCA9545

4-channel I²C switch with interrupt logic
and reset

Product data
Supersedes data of 2001 Nov 08

2002 Mar 28

4-channel I²C switch with interrupt logic and reset

PCA9545



FEATURES

- 1-of-4 bi-directional translating switches
- I²C interface logic; compatible with SMBus standards
- 4 active low interrupt inputs
- Active low interrupt output
- Active low reset input
- 2 address pins allowing up to 4 devices on the I²C bus
- Channel selection via I²C bus, in any combination
- Power up with all switch channels deselected
- Low RDS_{ON} switches
- Allows voltage level translation between 1.8 V, 2.5 V, 3.3 V and 5 V buses
- No glitch on power-up
- Supports hot insertion
- Low stand-by current
- Operating power supply voltage range of 2.3 V to 5.5 V
- 5 V tolerant Inputs
- 0 to 400 kHz clock frequency
- ESD protection exceeds 2000 V HBM per JESD22-A114, 150 V MM per JESD22-A115 and 1000 V per JESD22-C101
- Latch-up testing is done to JESDEC Standard JESD78 which exceeds 100 mA
- Package Offer: SO20, TSSOP20

DESCRIPTION

The PCA9545 is a quad bi-directional translating switch controlled via the I²C bus. The SCL/SDA upstream pair fans out to four downstream pairs, or channels. Any individual SCx/SDx channel or combination of channels can be selected, determined by the contents of the programmable control register. Four interrupt inputs, INT₀ to INT₃, one for each of the downstream pairs, are provided. One interrupt output, INT, acts as an AND of the four interrupt inputs.

An active-LOW reset input allows the PCA9545 to recover from a situation where one of the downstream I²C buses is stuck in a LOW state. Pulling the RESET pin LOW resets the I²C state machine and causes all the channels to be deselected as does the internal power on reset function.

The pass gates of the switches are constructed such that the V_{DD} pin can be used to limit the maximum high voltage which will be

passed by the PCA9545. This allows the use of different bus voltages on each pair, so that 1.8 V or 2.5 V or 3.3 V parts can communicate with 5 V parts without any additional protection. External pull-up resistors pull the bus up to the desired voltage level for each channel. All I/O pins are 5 V tolerant.

PIN CONFIGURATION

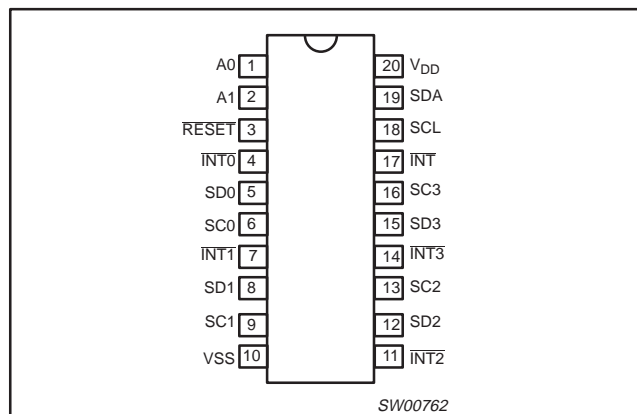

Figure 1. Pin configuration

PIN DESCRIPTION

PIN NUMBER	SYMBOL	FUNCTION
1	A0	Address input 0
2	A1	Address input 1
3	RESET	Active low reset input
4	INT ₀	Active low interrupt input 0
5	SD ₀	Serial data 0
6	SC ₀	Serial clock 0
7	INT ₁	Active low interrupt input 1
8	SD ₁	Serial data 1
9	SC ₁	Serial clock 1
10	V _{SS}	Supply ground
11	INT ₂	Active low interrupt input 2
12	SD ₂	Serial data 2
13	SC ₂	Serial clock 2
14	INT ₃	Active low interrupt input 3
15	SD ₃	Serial data 3
16	SC ₃	Serial clock 3
17	INT	Active low interrupt output
18	SCL	Serial clock line
19	SDA	Serial data line
20	V _{DD}	Supply voltage

ORDERING INFORMATION

PACKAGES	TEMPERATURE RANGE	ORDER CODE	DRAWING NUMBER
20-Pin Plastic SO	-40 to +85 °C	PCA9545D	SOT163-1
20-Pin Plastic TSSOP	-40 to +85 °C	PCA9545PW	SOT360-1

Standard packing quantities and other packaging data is available at www.philipslogic.com/packaging.

4-channel I²C switch with interrupt logic and reset

PCA9545

BLOCK DIAGRAM

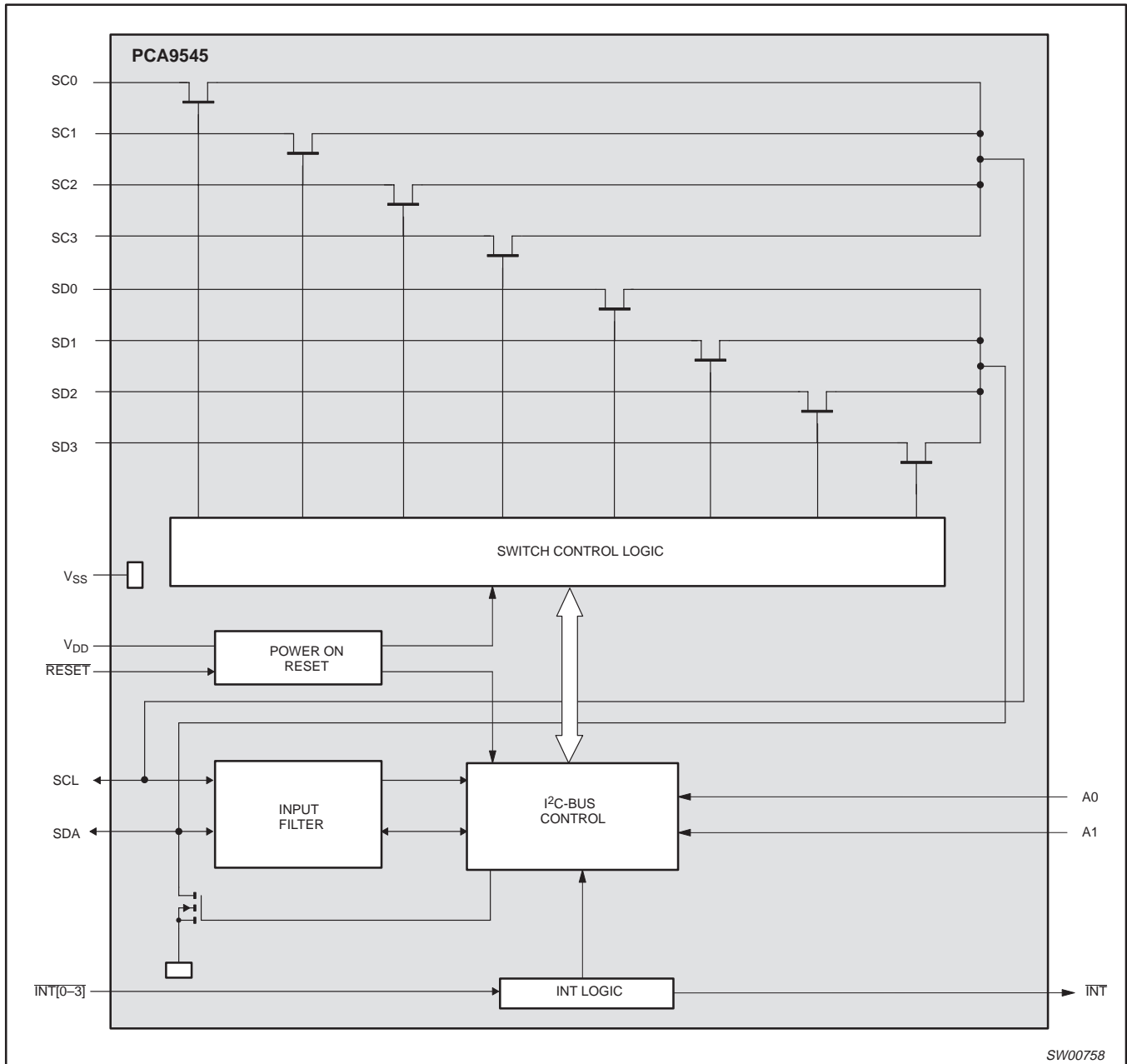

SW00758

Figure 2. Block diagram

4-channel I²C switch with interrupt logic and reset

PCA9545

DEVICE ADDRESS

Following a START condition the bus master must output the address of the slave it is accessing. The address of the PCA9545 is shown in Figure 3. To conserve power, no internal pullup resistors are incorporated on the hardware selectable address pins and they must be pulled HIGH or LOW.

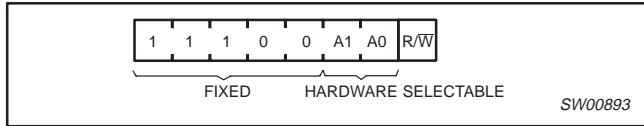

Figure 3. Slave address

The last bit of the slave address defines the operation to be performed. When set to logic 1, a read is selected while a logic 0 selects a write operation.

CONTROL REGISTER

Following the successful acknowledgement of the slave address, the bus master will send a byte to the PCA9545, which will be stored in the control register. If multiple bytes are received by the PCA9545, it will save the last byte received. This register can be written and read via the I²C bus.

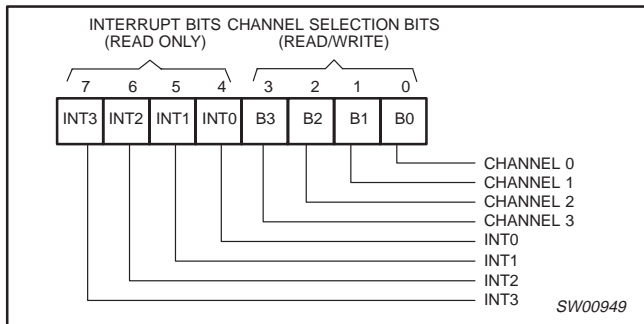

Figure 4. Control Register

CONTROL REGISTER DEFINITION

One or several SCx/SDx downstream pair, or channel, is selected by the contents of the control register. This register is written after the PCA9545 has been addressed. The 2 LSBs of the control byte are used to determine which channel is to be selected. When a channel is selected, the channel will become active after a stop condition has been placed on the I²C bus. This ensures that all SCx/SDx lines will be in a HIGH state when the channel is made active, so that no false conditions are generated at the time of connection.

Table 1. Control Register; Write — Channel Selection/
Read — Channel Status

INT3	INT2	INT1	INT0	B3	B2	B1	B0	COMMAND
X	X	X	X	X	X	X	0	Channel 0 disabled
							1	Channel 0 enabled
X	X	X	X	X	X	0	X	Channel 1 disabled
							1	Channel 1 enabled
X	X	X	X	X	0	X	X	Channel 2 disabled
							1	Channel 2 enabled
X	X	X	X	0	X	X	X	Channel 3 disabled
							1	Channel 3 enabled

NOTE: Several channels can be enabled at the same time.

Ex: B3 = 0, B2 = 1, B1 = 1, B0 = 0, means that channel 0 and 3 are disabled and channel 1 and 2 are enabled.

Care should be taken not to exceed the maximum bus capacity.

4-channel I²C switch with interrupt logic and reset

PCA9545

INTERRUPT HANDLING

The PCA9545 provides 4 interrupt inputs, one for each channel, and one open drain interrupt output. When an interrupt is generated by any device, it will be detected by the PCA9545 and the interrupt output will be driven LOW. The channel does not need to be active for detection of the interrupt. A bit is also set in the control register.

Bits 4 – 7 of the control register correspond to channels 0 – 3 of the PCA9545, respectively. Therefore, if an interrupt is generated by any device connected to channel 1, the state of the interrupt inputs is loaded into the control register when a read is accomplished.

Likewise, an interrupt on any device connected to channel 0 would cause bit 4 of the control register to be set on the read. The master can then address the PCA9545 and read the contents of the control register to determine which channel contains the device generating the interrupt. The master can then reconfigure the PCA9545 to select this channel, and locate the device generating the interrupt and clear it.

It should be noted that more than one device can be providing an interrupt on a channel, so it is up to the master to ensure that all devices on a channel are interrogated for an interrupt.

The interrupt inputs may be used as general purpose inputs if the interrupt function is not required.

If unused, interrupt input(s) must be connected to V_{DD} through a pull-up resistor.

Table 2. Control Register Read — Interrupt

INT3	INT2	INT1	INT0	B3	B2	B1	B0	COMMAND
X	X	X	0	X	X	X	X	No interrupt on channel 0
			1					Interrupt on channel 0
X	X	0	X	X	X	X	X	No interrupt on channel 1
		1						Interrupt on channel 1
X	0	X	X	X	X	X	X	No interrupt on channel 2
	1							Interrupt on channel 2
0	X	X	X	X	X	X	X	No interrupt on channel 3
1								Interrupt on channel 3

NOTE: Several interrupts can be active at the same time.
 Ex: INT3 = 0, INT2 = 1, INT1 = 1, INT0 = 0, means that there is no interrupt on channels 0 and 3, and there is interrupt on channels 1 and 2.

RESET INPUT

The RESET input is an active-LOW signal which may be used to recover from a bus fault condition. By asserting this signal LOW for a minimum of t_{WL}, the PCA9545 will reset its registers and I²C state machine and will deselect all channels. The RESET input must be connected to V_{DD} through a pull-up resistor.

POWER-ON RESET

When power is applied to V_{DD}, an internal Power On Reset holds the PCA9545 in a reset state until V_{DD} has reached V_{POR}. At this point, the reset condition is released and the PCA9545 registers and I²C state machine are initialized to their default states, all zeroes causing all the channels to be deselected.

VOLTAGE TRANSLATION

The pass gate transistors of the PCA9545 are constructed such that the V_{DD} voltage can be used to limit the maximum voltage that will be passed from one I²C bus to another.

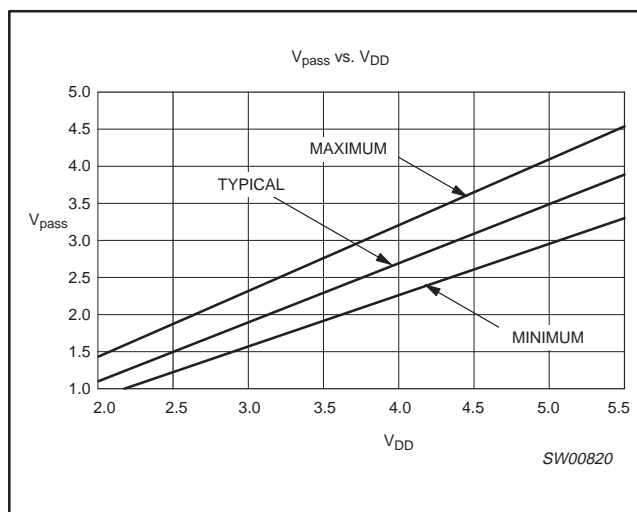

Figure 5. V_{pass} voltage vs. V_{DD}

Figure 5 shows the voltage characteristics of the pass gate transistors (note that the graph was generated using the data specified in the DC Characteristics section of this datasheet). In order for the PCA9545 to act as a voltage translator, the V_{pass} voltage should be equal to, or lower than the lowest bus voltage. For example, if the main bus was running at 5 V, and the downstream buses were 3.3 V and 2.7 V, then V_{pass} should be equal to or below 2.7 V to effectively clamp the downstream bus voltages. Looking at Figure 5, we see that V_{pass} (max.) will be at 2.7 V when the PCA9545 supply voltage is 3.5 V or lower so the PCA9545 supply voltage could be set to 3.3 V. Pull-up resistors can then be used to bring the bus voltages to their appropriate levels (see Figure 12).

More Information can be found in Application Note AN262 PCA954X family of I²C/SMBus multiplexers and switches.

4-channel I²C switch with interrupt logic and reset

PCA9545

CHARACTERISTICS OF THE I²C-BUS

The I²C-bus is for 2-way, 2-line communication between different ICs or modules. The two lines are a serial data line (SDA) and a serial clock line (SCL). Both lines must be connected to a positive supply via a pull-up resistor when connected to the output stages of a device. Data transfer may be initiated only when the bus is not busy.

Bit transfer

One data bit is transferred during each clock pulse. The data on the SDA line must remain stable during the HIGH period of the clock pulse as changes in the data line at this time will be interpreted as control signals (see Figure 6).

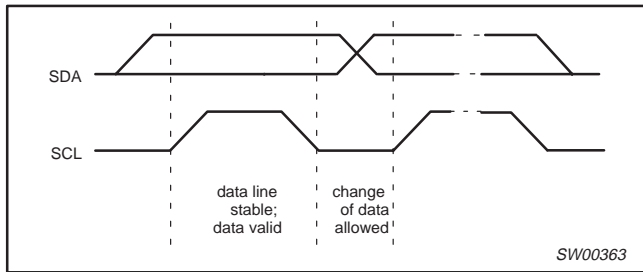

Figure 6. Bit transfer

Start and stop conditions

Both data and clock lines remain HIGH when the bus is not busy. A HIGH-to-LOW transition of the data line, while the clock is HIGH is defined as the start condition (S). A LOW-to-HIGH transition of the data line while the clock is HIGH is defined as the stop condition (P) (see Figure 7).

System configuration

A device generating a message is a 'transmitter', a device receiving is the 'receiver'. The device that controls the message is the 'master' and the devices which are controlled by the master are the 'slaves' (see Figure 8).

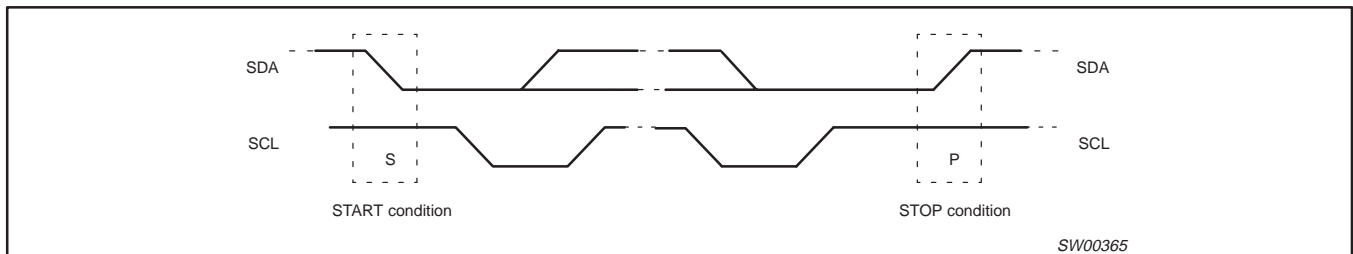

Figure 7. Definition of start and stop conditions

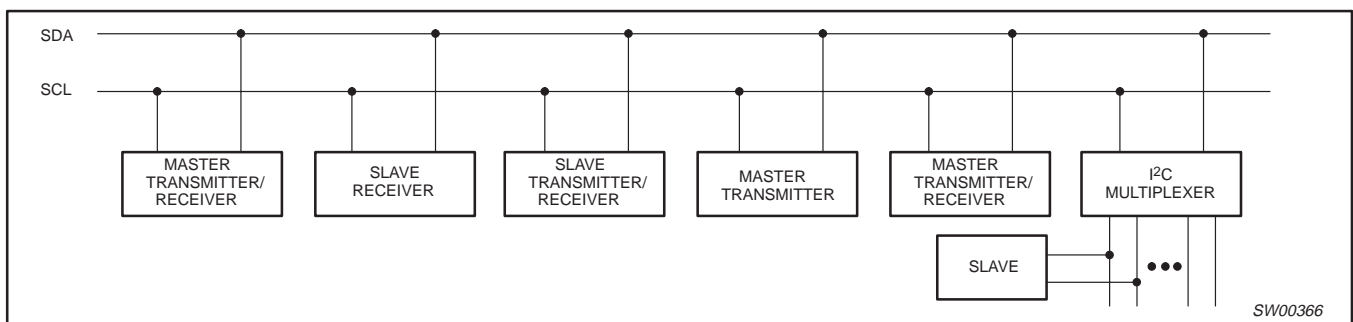

Figure 8. System configuration

4-channel I²C switch with interrupt logic and reset

PCA9545

Acknowledge

The number of data bytes transferred between the start and the stop conditions from transmitter to receiver is not limited. Each byte of eight bits is followed by one acknowledge bit. The acknowledge bit is a HIGH level put on the bus by the transmitter whereas the master generates an extra acknowledge related clock pulse.

A slave receiver which is addressed must generate an acknowledge after the reception of each byte. Also a master must generate an acknowledge after the reception of each byte that has been clocked out of the slave transmitter. The device that acknowledges has to pull down the SDA line during the acknowledge clock pulse, so that the SDA line is stable LOW during the HIGH period of the acknowledge related clock pulse, set-up and hold times must be taken into account.

A master receiver must signal an end of data to the transmitter by not generating an acknowledge on the last byte that has been clocked out of the slave. In this event, the transmitter must leave the data line HIGH to enable the master to generate a stop condition.

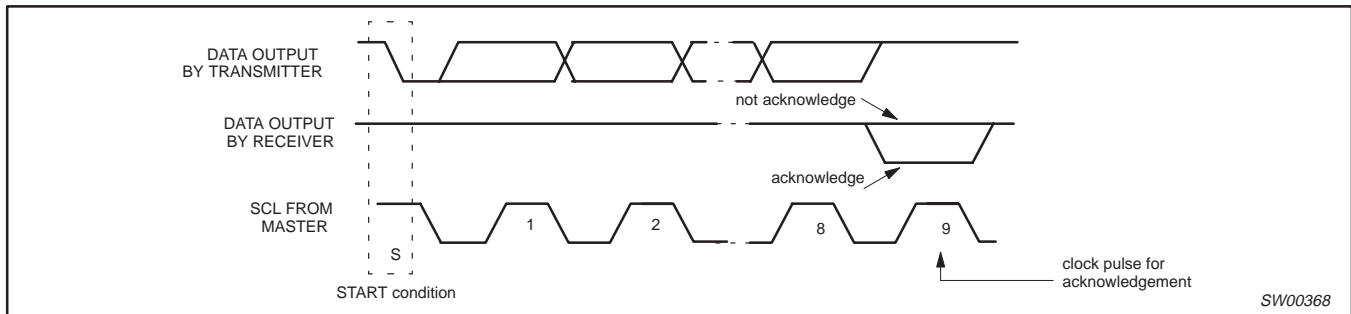

Figure 9. Acknowledgement on the I²C-bus

Bus transactions

Data is transmitted to the PCA9545 control register using the write mode as shown in Figure 10.

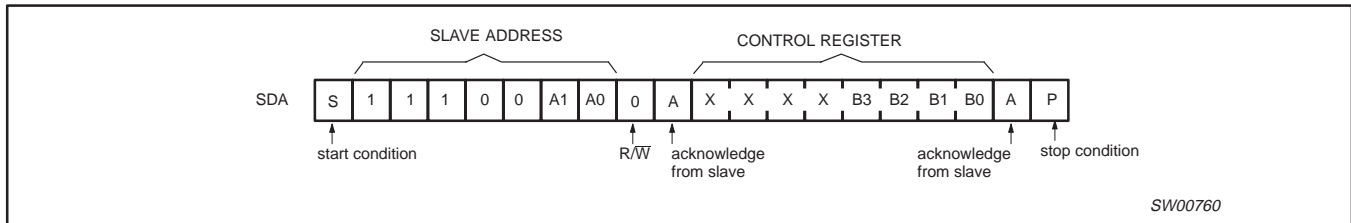

Figure 10. WRITE control register

Data is read from PCA9545 control register using the read mode as shown in Figure 11.

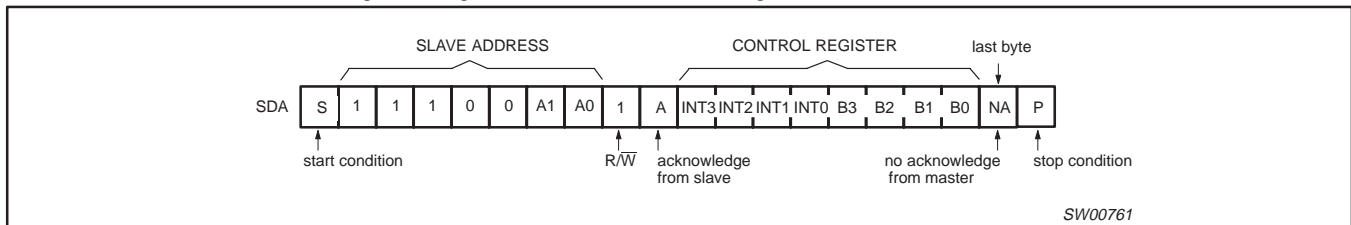

Figure 11. READ control register

4-channel I²C switch with interrupt logic and reset

PCA9545

TYPICAL APPLICATION

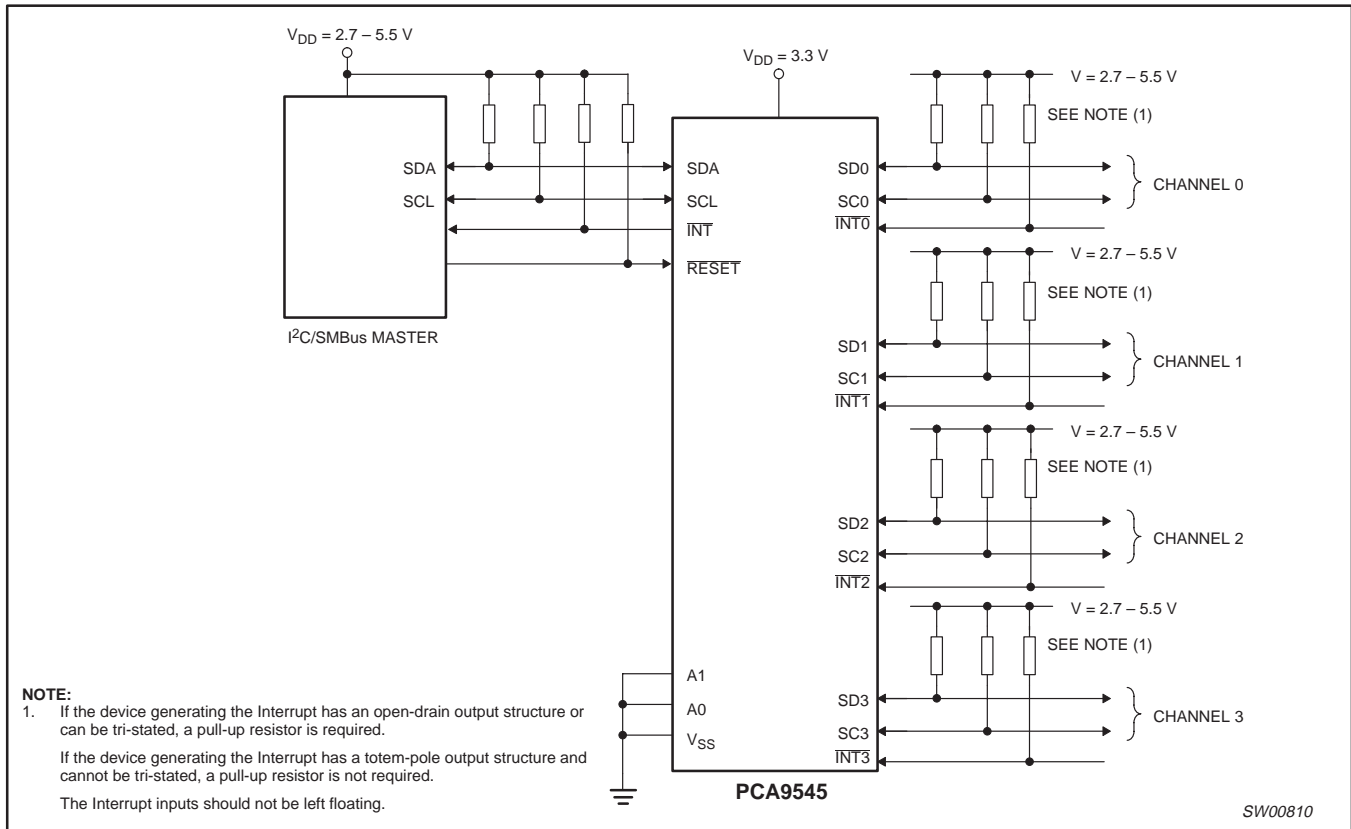

Figure 12. Typical application

4-channel I²C switch with interrupt logic and reset

PCA9545

ABSOLUTE MAXIMUM RATINGS^{1, 2}

In accordance with the Absolute Maximum Rating System (IEC 134). Voltages are referenced to GND (ground = 0 V).

SYMBOL	PARAMETER	CONDITIONS	RATING		UNIT
			MIN	MAX	
V _{DD}	DC supply voltage		-0.5	+7.0	V
V _I	DC input voltage		-0.5	+7.0	V
I _I	DC input current		—	±20	mA
I _O	DC output current		—	±25	mA
I _{DD}	DC Supply current		—	±100	mA
I _{SS}	DC Supply current		—	±100	mA
P _{tot}	total power dissipation		—	400	mW
T _{stg}	Storage temperature range		-60	+150	°C
T _{amb}	Operating ambient temperature		-40	+85	°C

NOTES:

- Stresses beyond those listed may cause permanent damage to the device. These are stress ratings only and functional operation of the device at these or any other conditions beyond those indicated under "recommended operating conditions" is not implied. Exposure to absolute-maximum-rated conditions for extended periods may affect device reliability.
- The performance capability of a high-performance integrated circuit in conjunction with its thermal environment can create junction temperatures which are detrimental to reliability. The maximum junction temperature of this integrated circuit should not exceed 150 °C.

DC CHARACTERISTICSV_{DD} = 2.3 to 3.6 V; V_{SS} = 0 V; T_{amb} = -40 to +85 °C; unless otherwise specified. (See page 11 for V_{DD} = 3.6 to 5.5 V.)

SYMBOL	PARAMETER	TEST CONDITIONS	LIMITS			UNIT
			MIN	TYP	MAX	
Supply						
V _{DD}	Supply voltage		2.3	—	3.6	V
I _{DD}	Supply current	Operating mode; V _{DD} = 3.6 V; no load; V _I = V _{DD} or V _{SS} ; f _{SCL} = 100 kHz	—	30	100	μA
I _{stb}	Standby current	Standby mode; V _{DD} = 3.6 V; no load; V _I = V _{DD} or V _{SS}	—	20	100	μA
V _{POR}	Power-on reset voltage	no load; V _I = V _{DD} or V _{SS}	—	1.6	2.1	V
Input SCL; input/output SDA						
V _{IL}	LOW level input voltage		-0.5	—	0.3 V _{DD}	V
V _{IH}	HIGH level input voltage		0.7 V _{DD}	—	6	V
I _{OL}	LOW level output current	V _{OL} = 0.4 V	3	—	—	mA
		V _{OL} = 0.6 V	6	—	—	
I _L	Leakage current	V _I = V _{DD} or V _{SS}	-1	—	+1	μA
C _i	Input capacitance	V _I = V _{SS}	—	12	13	pF
Select inputs A0 to A1 / INT0 to INT3 / RESET						
V _{IL}	LOW level input voltage		-0.5	—	+0.3 V _{DD}	V
V _{IH}	HIGH level input voltage		0.7 V _{DD}	—	V _{DD} + 0.5	V
I _{LI}	Input leakage current	pin at V _{DD} or V _{SS}	-1	—	+1	μA
C _i	Input capacitance	V _I = V _{SS}	—	1.6	3	pF
Pass Gate						
R _{ON}	Switch resistance	V _{DD} = 3.0 to 3.6 V, V _O = 0.4 V, I _O = 15 mA	5	20	30	Ω
		V _{DD} = 2.3 to 2.7 V, V _O = 0.4 V, I _O = 10 mA	7	26	55	
V _{Pass}	Switch output voltage	V _{swin} = V _{DD} = 3.3 V; I _{swout} = -100 μA	—	2.2	—	V
		V _{swin} = V _{DD} = 3.0 to 3.6 V; I _{swout} = -100 μA	1.6	—	2.8	
		V _{swin} = V _{DD} = 2.5 V; I _{swout} = -100 μA	—	1.5	—	
		V _{swin} = V _{DD} = 2.3 to 2.7 V; I _{swout} = -100 μA	1.1	—	2.0	
I _L	Leakage current	V _I = V _{DD} or V _{SS}	-1	—	+1	μA
C _{io}	Input/output capacitance	V _I = V _{SS}	—	3	5	pF
INT Output						
I _{OL}	LOW level output current	V _{OL} = 0.4 V	3	—	—	mA
I _{OH}	HIGH level output current		—	—	+100	μA

4-channel I²C switch with interrupt logic and reset

PCA9545

DC CHARACTERISTICSV_{DD} = 3.6 to 5.5 V; V_{SS} = 0 V; T_{amb} = -40 to +85 °C; unless otherwise specified. (See page 10 for V_{DD} = 2.3 to 3.6 V.)

SYMBOL	PARAMETER	TEST CONDITIONS	LIMITS			UNIT
			MIN	TYP	MAX	
Supply						
V _{DD}	Supply voltage		3.6	—	5.5	V
I _{DD}	Supply current	Operating mode; V _{DD} = 5.5 V; no load; V _I = V _{DD} or V _{SS} ; f _{SCL} = 100 kHz	—	575	600	μA
I _{stb}	Standby current	Standby mode; V _{DD} = 5.5 V; no load; V _I = V _{DD} or V _{SS}	—	130	200	μA
V _{POR}	Power-on reset voltage	no load; V _I = V _{DD} or V _{SS}	—	1.6	2.1	V
Input SCL; input/output SDA						
V _{IL}	LOW level input voltage		-0.5	—	0.3 V _{DD}	V
V _{IH}	HIGH level input voltage		0.7 V _{DD}	—	6	V
I _{OL}	LOW level output current	V _{OL} = 0.4 V	3	—	—	mA
		V _{OL} = 0.6 V	6	—	—	mA
I _{IL}	LOW level input current	V _I = V _{SS}	-10	—	+10	μA
I _{IH}	HIGH level input current	V _I = V _{DD}	—	—	+100	μA
C _i	Input capacitance	V _I = V _{SS}	—	12	13	pF
Select inputs A0 to A1 / INT0 to INT3 / RESET						
V _{IL}	LOW level input voltage		-0.5	—	+0.3 V _{DD}	V
V _{IH}	HIGH level input voltage		0.7 V _{DD}	—	V _{DD} + 0.5	V
I _{LI}	Input leakage current	pin at V _{DD} or V _{SS}	-1	—	+50	μA
C _i	Input capacitance	V _I = V _{SS}	—	1.6	3	pF
Pass Gate						
R _{ON}	Switch resistance	V _{CC} = 4.5 to 5.5 V, V _O = 0.4 V, I _O = 15 mA	4	11	24	Ω
V _{Pass}	Switch output voltage	V _{swin} = V _{DD} = 5.0 V; I _{swout} = -100 μA	—	3.5	—	V
		V _{swin} = V _{DD} = 4.5 to 5.5 V; I _{swout} = -100 μA	2.6	—	4.5	V
I _L	Leakage current	V _I = V _{DD} or V _{SS}	-1	—	+100	μA
C _{io}	Input/output capacitance	V _I = V _{SS}	—	3	5	pF
INT Output						
I _{OL}	LOW level output current	V _{OL} = 0.4 V	3	—	—	mA
I _{OH}	HIGH level output current		—	—	+100	μA

4-channel I²C switch with interrupt logic and reset

PCA9545

AC CHARACTERISTICS

SYMBOL	PARAMETER	STANDARD-MODE I ² C-BUS		FAST-MODE I ² C-BUS		UNIT
		MIN	MAX	MIN	MAX	
t _{pd}	Propagation delay from SDA to SD _n or SCL to SC _n	—	0.3 ¹	—	0.3 ¹	ns
f _{SCL}	SCL clock frequency	0	100	0	400	kHz
t _{BUF}	Bus free time between a STOP and START condition	4.7	—	1.3	—	μs
t _{HD;STA}	Hold time (repeated) START condition After this period, the first clock pulse is generated	4.0	—	0.6	—	μs
t _{LOW}	LOW period of the SCL clock	4.7	—	1.3	—	μs
t _{HIGH}	HIGH period of the SCL clock	4.0	—	0.6	—	μs
t _{SU;STA}	Set-up time for a repeated START condition	4.7	—	0.6	—	μs
t _{SU;STO}	Set-up time for STOP condition	4.0	—	0.6	—	μs
t _{HD;DAT}	Data hold time	0 ²	3.45	0 ²	0.9	μs
t _{SU;DAT}	Data set-up time	250	—	100	—	ns
t _R	Rise time of both SDA and SCL signals	—	1000	20 + 0.1C _b ³	300	ns
t _F	Fall time of both SDA and SCL signals	—	300	20 + 0.1C _b ³	300	μs
C _b	Capacitive load for each bus line	—	400	—	400	μs
t _{SP}	Pulse width of spikes which must be suppressed by the input filter	—	50	—	50	ns
t _{VD;DATL}	Data valid (HL)	—	1	—	1	μs
t _{VD;DATH}	Data valid (LH)	—	0.6	—	0.6	μs
t _{VD;ACK}	Data valid Acknowledge	—	1	—	1	μs
INT						
t _{iv}	INT _n to INT active valid time	—	4	—	4	μs
t _{ir}	INT _n to INT inactive delay time	—	2	—	2	μs
L _{pwr}	LOW level pulse width rejection or INT _n inputs	1	—	1	—	μs
H _{pwr}	HIGH level pulse width rejection or INT _n inputs	0.5	—	0.5	—	μs
RESET						
t _{WL(rst)}	Pulse width low reset	4	—	4	—	ns
t _{rst}	Reset time (SDA clear)	500	—	500	—	ns
t _{REC;STA}	Recovery to Start	0	—	0	—	ns

NOTES:

1. Pass gate propagation delay is calculated from the 20 Ω typical R_{ON} and the 15 pF load capacitance.
2. A device must internally provide a hold time of at least 300 ns for the SDA signal (referred to the V_{IHmin} of the SCL signal) in order to bridge the undefined region of the falling edge of SCL.
3. C_b = total capacitance of one bus line in pF.

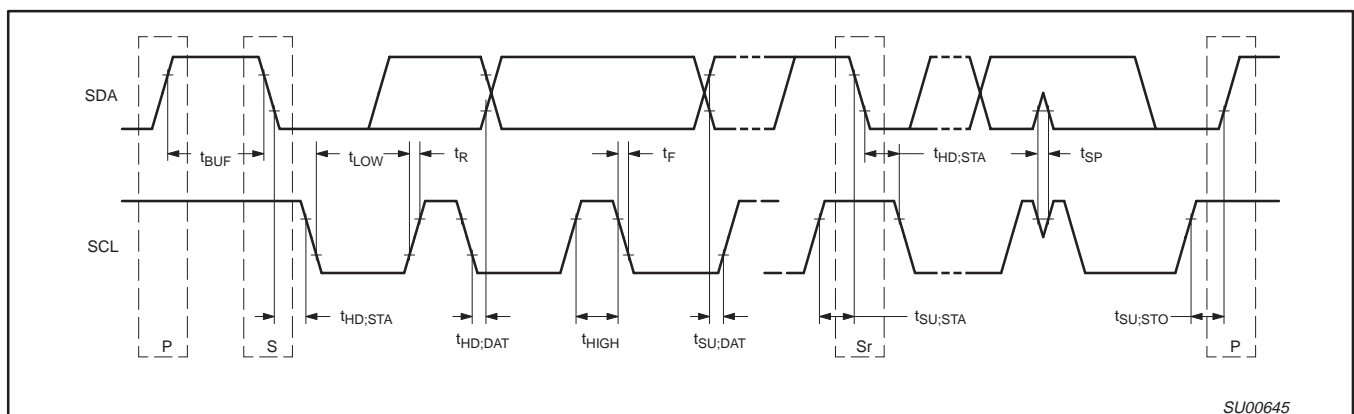

Figure 13. Definition of timing on the I²C-bus

4-channel I²C switch with interrupt logic and reset

PCA9545

SO20: plastic small outline package; 20 leads; body width 7.5 mm

SOT163-1

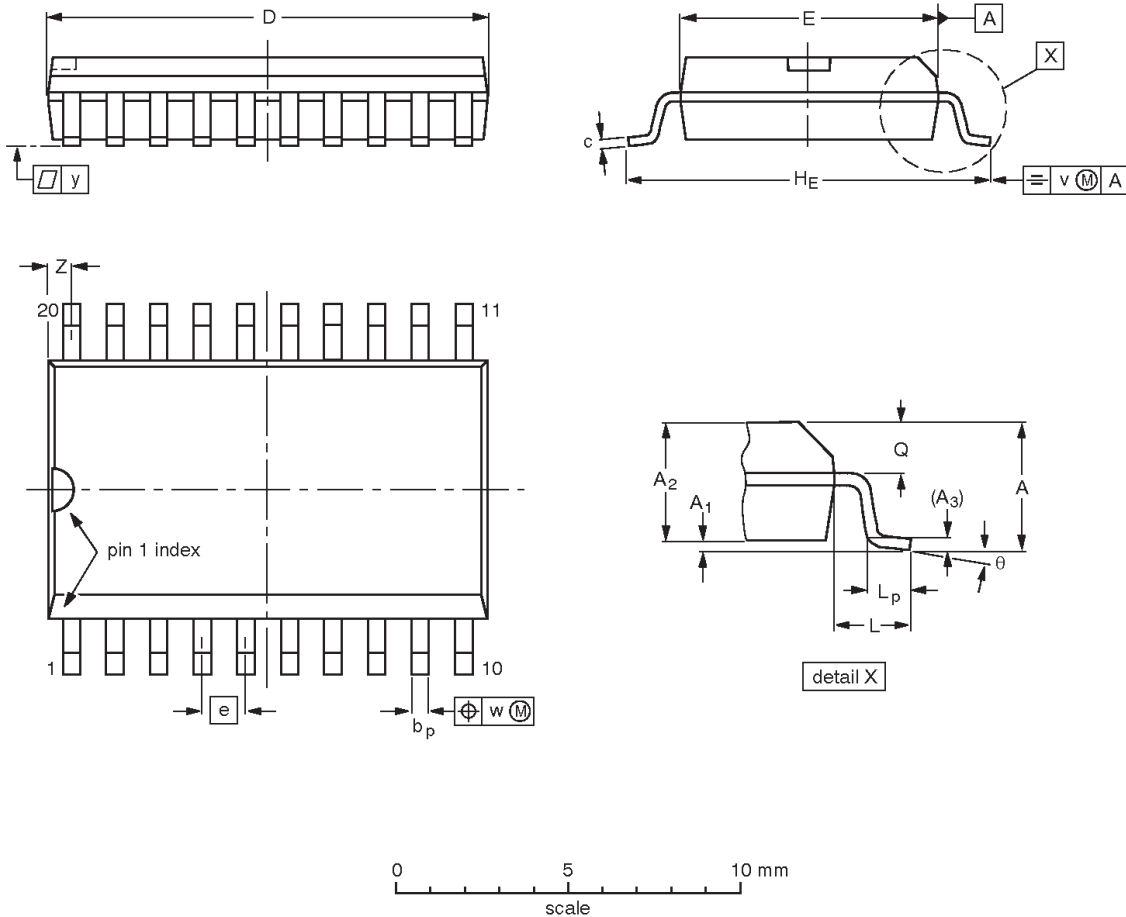

DIMENSIONS (inch dimensions are derived from the original mm dimensions)

UNIT	A max.	A ₁	A ₂	A ₃	b _p	c	D ⁽¹⁾	E ⁽¹⁾	e	HE	L	L _p	Q	v	w	y	z ⁽¹⁾	θ
mm	2.65	0.30 0.10	2.45 2.25	0.25	0.49 0.36	0.32 0.23	13.0 12.6	7.6 7.4	1.27	10.65 10.00	1.4	1.1 0.4	1.1 1.0	0.25	0.25	0.1	0.9 0.4	8° 0°
inches	0.10	0.012 0.004	0.096 0.089	0.01	0.019 0.014	0.013 0.009	0.51 0.49	0.30 0.29	0.050	0.419 0.394	0.055	0.043 0.016	0.043 0.039	0.01	0.01	0.004	0.035 0.016	

Note

1. Plastic or metal protrusions of 0.15 mm maximum per side are not included.

OUTLINE VERSION	REFERENCES				EUROPEAN PROJECTION	ISSUE DATE
	IEC	JEDEC	EIAJ			
SOT163-1	075E04	MS-013				97-05-22 99-12-27

4-channel I²C switch with interrupt logic and reset

PCA9545

TSSOP20: plastic thin shrink small outline package; 20 leads; body width 4.4 mm

SOT360-1

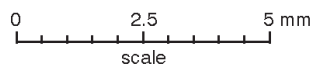
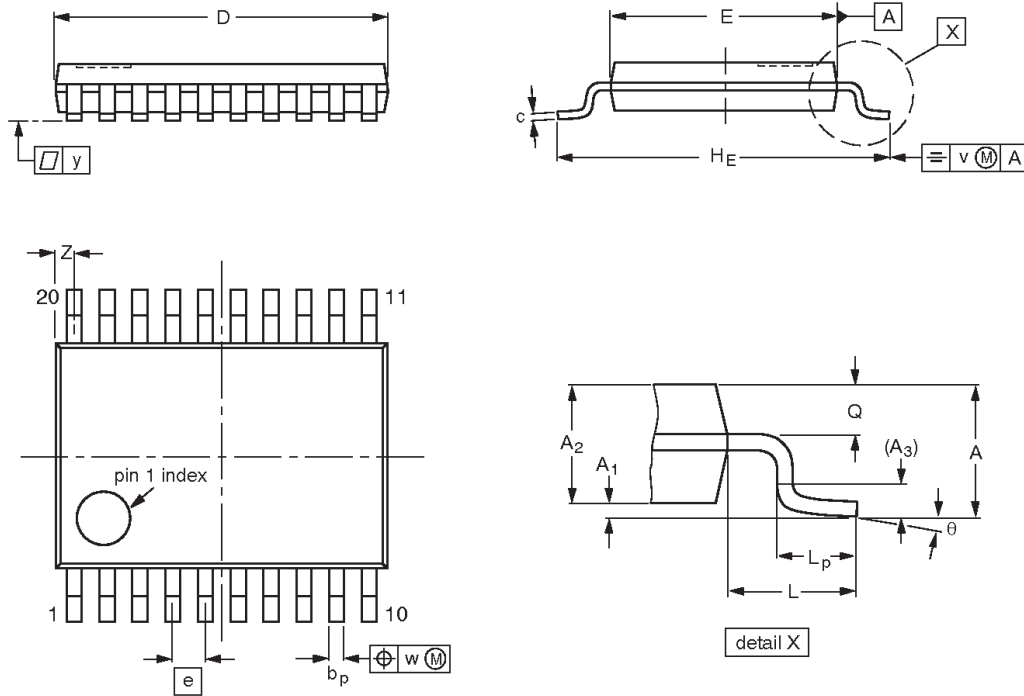

DIMENSIONS (mm are the original dimensions)

UNIT	A max.	A ₁	A ₂	A ₃	b _p	c	D ⁽¹⁾	E ⁽²⁾	e	H _E	L	L _p	Q	v	w	y	Z ⁽¹⁾	θ
mm	1.10	0.15 0.05	0.95 0.80	0.25	0.30 0.19	0.2 0.1	6.6 6.4	4.5 4.3	0.65	6.6 6.2	1.0	0.75 0.50	0.4 0.3	0.2	0.13	0.1	0.5 0.2	8° 0°

Notes

1. Plastic or metal protrusions of 0.15 mm maximum per side are not included.
2. Plastic interlead protrusions of 0.25 mm maximum per side are not included.

OUTLINE VERSION	REFERENCES				EUROPEAN PROJECTION	ISSUE DATE
	IEC	JEDEC	EIAJ			
SOT360-1		MO-153				95-02-04 99-12-27

4-channel I²C switch with interrupt logic and reset

PCA9545



Purchase of Philips I²C components conveys a license under the Philips' I²C patent to use the components in the I²C system provided the system conforms to the I²C specifications defined by Philips. This specification can be ordered using the code 9398 393 40011.

Data sheet status

Data sheet status ^[1]	Product status ^[2]	Definitions
Objective data	Development	This data sheet contains data from the objective specification for product development. Philips Semiconductors reserves the right to change the specification in any manner without notice.
Preliminary data	Qualification	This data sheet contains data from the preliminary specification. Supplementary data will be published at a later date. Philips Semiconductors reserves the right to change the specification without notice, in order to improve the design and supply the best possible product.
Product data	Production	This data sheet contains data from the product specification. Philips Semiconductors reserves the right to make changes at any time in order to improve the design, manufacturing and supply. Changes will be communicated according to the Customer Product/Process Change Notification (CPCN) procedure SNW-SQ-650A.

[1] Please consult the most recently issued data sheet before initiating or completing a design.

[2] The product status of the device(s) described in this data sheet may have changed since this data sheet was published. The latest information is available on the Internet at URL <http://www.semiconductors.philips.com>.

Definitions

Short-form specification — The data in a short-form specification is extracted from a full data sheet with the same type number and title. For detailed information see the relevant data sheet or data handbook.

Limiting values definition — Limiting values given are in accordance with the Absolute Maximum Rating System (IEC 60134). Stress above one or more of the limiting values may cause permanent damage to the device. These are stress ratings only and operation of the device at these or at any other conditions above those given in the Characteristics sections of the specification is not implied. Exposure to limiting values for extended periods may affect device reliability.

Application information — Applications that are described herein for any of these products are for illustrative purposes only. Philips Semiconductors make no representation or warranty that such applications will be suitable for the specified use without further testing or modification.

Disclaimers

Life support — These products are not designed for use in life support appliances, devices or systems where malfunction of these products can reasonably be expected to result in personal injury. Philips Semiconductors customers using or selling these products for use in such applications do so at their own risk and agree to fully indemnify Philips Semiconductors for any damages resulting from such application.

Right to make changes — Philips Semiconductors reserves the right to make changes, without notice, in the products, including circuits, standard cells, and/or software, described or contained herein in order to improve design and/or performance. Philips Semiconductors assumes no responsibility or liability for the use of any of these products, conveys no license or title under any patent, copyright, or mask work right to these products, and makes no representations or warranties that these products are free from patent, copyright, or mask work right infringement, unless otherwise specified.

Contact information

For additional information please visit
<http://www.semiconductors.philips.com>. Fax: +31 40 27 24825

© Koninklijke Philips Electronics N.V. 2002
 All rights reserved. Printed in U.S.A.

Date of release: 03-02

For sales offices addresses send e-mail to:
sales.addresses@www.semiconductors.philips.com

Document order number:

9397 750 09608

Let's make things better.