

DATA SHEET

**PCA3351C; 52C; 53C;
PCD3351A; 52A; 53A**
8-bit microcontrollers with DTMF
generator and 128 bytes EEPROM

Product specification
Supersedes data of 1996 Dec 18
File under Integrated Circuits, IC03

1999 Oct 28

8-bit microcontrollers with DTMF generator and 128 bytes EEPROM

**PCA3351C; 52C; 53C;
PCD3351A; 52A; 53A**

CONTENTS	9	TIMING
1 FEATURES	10	RESET
2 GENERAL DESCRIPTION	11	IDLE MODE
3 ORDERING INFORMATION	12	STOP MODE
4 BLOCK DIAGRAM	13	INSTRUCTION SET RESTRICTIONS
5 PINNING INFORMATION	14	OVERVIEW OF PORT AND POWER-ON-RESET CONFIGURATIONS
5.1 Pinning	15	SUMMARY OF DERIVATIVE REGISTERS
5.2 Pin description	16	HANDLING
6 FREQUENCY GENERATOR	17	LIMITING VALUES
6.1 Frequency generator derivative registers	18	DC CHARACTERISTICS
6.2 Melody output (P1.7/MDY)	19	AC CHARACTERISTICS
6.3 Frequency registers	20	PACKAGE OUTLINES
6.4 DTMF frequencies	21	SOLDERING
6.5 Modem frequencies	21.1	Reflow soldering
6.6 Musical scale frequencies	21.2	Wave soldering
7 EEPROM AND TIMER 2 ORGANIZATION	21.3	DIP
7.1 EEPROM registers	21.4	Repairing soldered joints
7.2 EEPROM latches	22	DEFINITIONS
7.3 EEPROM flags	23	LIFE SUPPORT APPLICATIONS
7.4 EEPROM macros		
7.5 EEPROM access		
7.6 Timer 2		
8 DERIVATIVE INTERRUPTS		

8-bit microcontrollers with DTMF generator and 128 bytes EEPROM

PCA3351C; 52C; 53C;
PCD3351A; 52A; 53A

1 FEATURES

- 8-bit CPU, ROM, RAM, EEPROM and I/O; all in one (28-lead or 32-lead) package
- ROM:
 - 2 kbytes (PCA3351C and PCD3351A)
 - 4 kbytes (PCA3352C and PCD3352A)
 - 6 kbytes (PCA3353C and PCD3353A)
- RAM:
 - 64 bytes (PCA3351C and PCD3351A)
 - 128 bytes (PCA3352C, PCD3352A, PCA3353C and PCD3353A)
- 128 bytes Electrically Erasable Programmable Read-Only Memory (EEPROM)
- Over 100 instructions (based on MAB8048) all of 1 or 2 cycles
- 20 quasi-bidirectional I/O port lines
- 8-bit programmable Timer/event counter 1
- 8-bit reloadable Timer 2
- Three single-level vectored interrupts:
 - external
 - 8-bit programmable Timer/event counter 1
 - derivative; triggered by reloadable Timer 2
- Two test inputs, one of which also serves as the external interrupt input
- DTMF, modem, musical tone generator
- Reference for supply and temperature-independent tone output
- Filtering for low output distortion (CEPT compatible)
- Melody output for ringer application
- Power-on-reset
- Stop and Idle modes
- Supply voltage: 1.8 to 6 V (DTMF tone output and EEPROM erase/write from 2.5 V)
- Clock frequency: 1 to 16 MHz (3.58 MHz for DTMF suggested)
- Operating ambient temperature: –25 to +70 °C or 0 to 50 °C
- Manufactured in silicon gate CMOS process.

2 GENERAL DESCRIPTION

This data sheet details the specific properties of the devices referred to. The shared properties of the PCD33xxA family of microcontrollers are described in the “PCD33xxA family” data sheet, which should be read in conjunction with this publication.

- ‘PCA3351C; 52C; 53C’ denotes the types PCA3351C, PCA3352C and PCA3353C. Unless specified, these types will hereafter be referred to collectively as ‘PCA335xC’.
- ‘PCD3351A; 52A; 53A’ denotes the types PCD3351A, PCD3352A, PCD3353A. Unless specified, these types will hereafter be referred to collectively as ‘PCD335xA’.

The PCA335xC and PCD335xA are microcontrollers designed primarily for telephony applications. They include an on-chip generator for dual tone multifrequency (DTMF), modem and musical tones. In addition to dialling, generated frequencies can be made available as square waves for melody generation, providing ringer operation.

The PCA335xC and PCD335xA also incorporate 128 bytes of EEPROM, permitting data storage without battery backup. The EEPROM can be used for storing telephone numbers, particularly for implementing redial functions.

The PCA335xC and PCD335xA can be emulated with the OTP microcontrollers PCD3755A and PCD3755E. See Chapter 14, Table 25.

The instruction set is similar to that of the MAB8048 and is a sub-set of that listed in the “PCD33xxA family” data sheet.

The differences between PCA335xC and PCD335xA are shown in Table 1.

Table 1 Differences: PCA335xC and PCD335xA

TYPE	V _{POR}	AMBIENT TEMP. RANGE
PCA335xC	fixed at 2.0 V ±0.3 V	0 to 50 °C
PCD335xA	(1.2 to 3.6 V) ±0.5 V ⁽¹⁾	–25 to +70 °C

Note

1. See Chapter 14, Table 26.

8-bit microcontrollers with DTMF generator
and 128 bytes EEPROM

PCA3351C; 52C; 53C;
PCD3351A; 52A; 53A

3 ORDERING INFORMATION

TYPE NUMBER ⁽¹⁾	PACKAGE		
	NAME	DESCRIPTION	VERSION
PCA335xCP	DIP28	plastic dual in-line package; 28 leads (600 mil)	SOT117-1
PCD335xAP			
PCA335xCT	SO28	plastic small outline package; 28 leads; body width 7.5 mm	SOT136-1
PCD335xAT			
PCA335xCH	LQFP32	plastic low profile quad flat package; 32 leads; body 7 × 7 × 1.4 mm	SOT358-1
PCD335xAH			

Note

1. The types:

- a) PCA335xC denotes: PCA3351C, PCA3352C or PCA3353C.
- b) PCD335xA denotes: PCD3351A, PCD3352A or PCD3353A.

8-bit microcontrollers with DTMF generator
and 128 bytes EEPROM

PCA3351C; 52C; 53C;
PCD3351A; 52A; 53A

4 BLOCK DIAGRAM

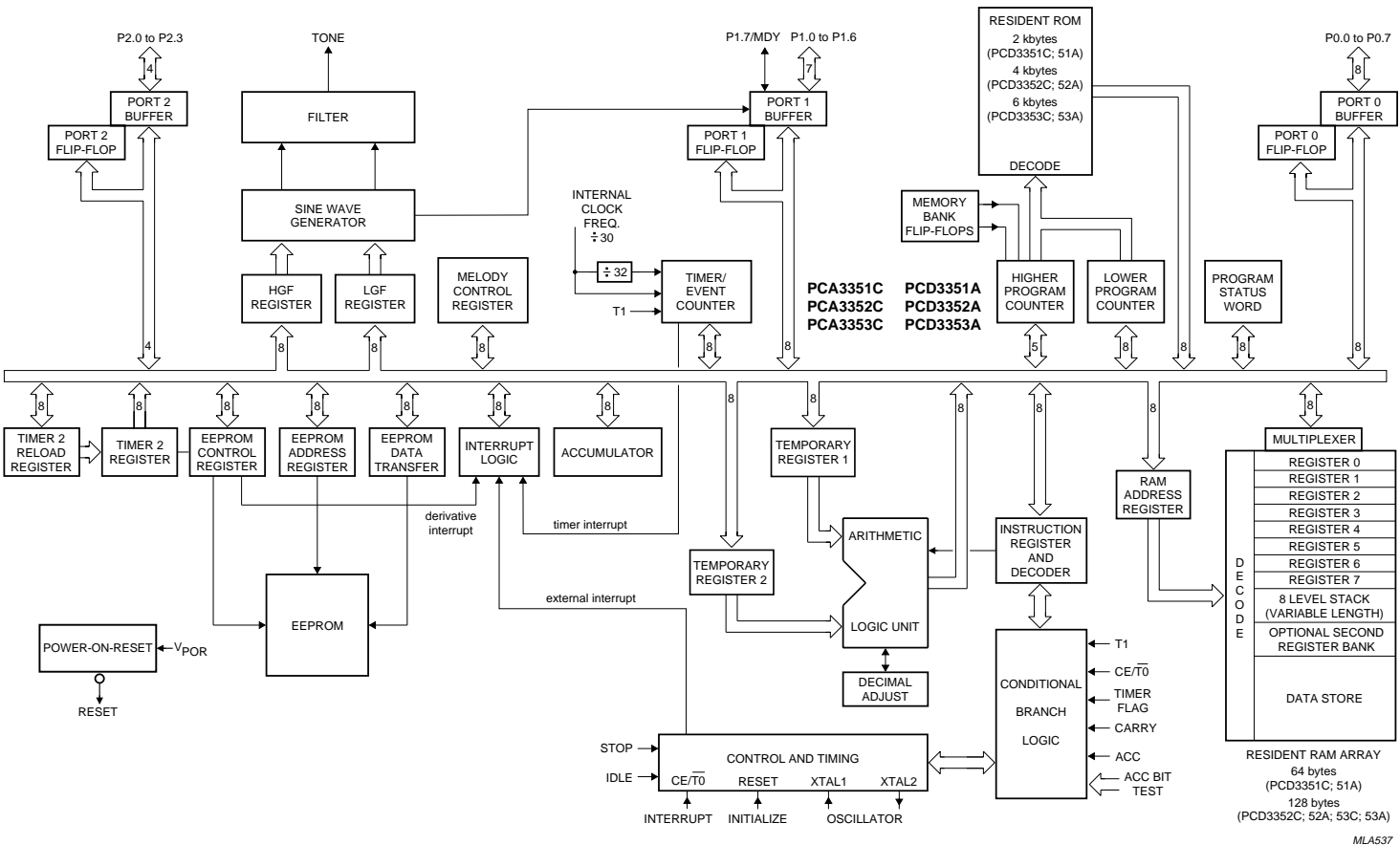

Fig.1 Block diagram.

8-bit microcontrollers with DTMF generator
and 128 bytes EEPROM

PCA3351C; 52C; 53C;
PCD3351A; 52A; 53A

5 PINNING INFORMATION

5.1 Pinning

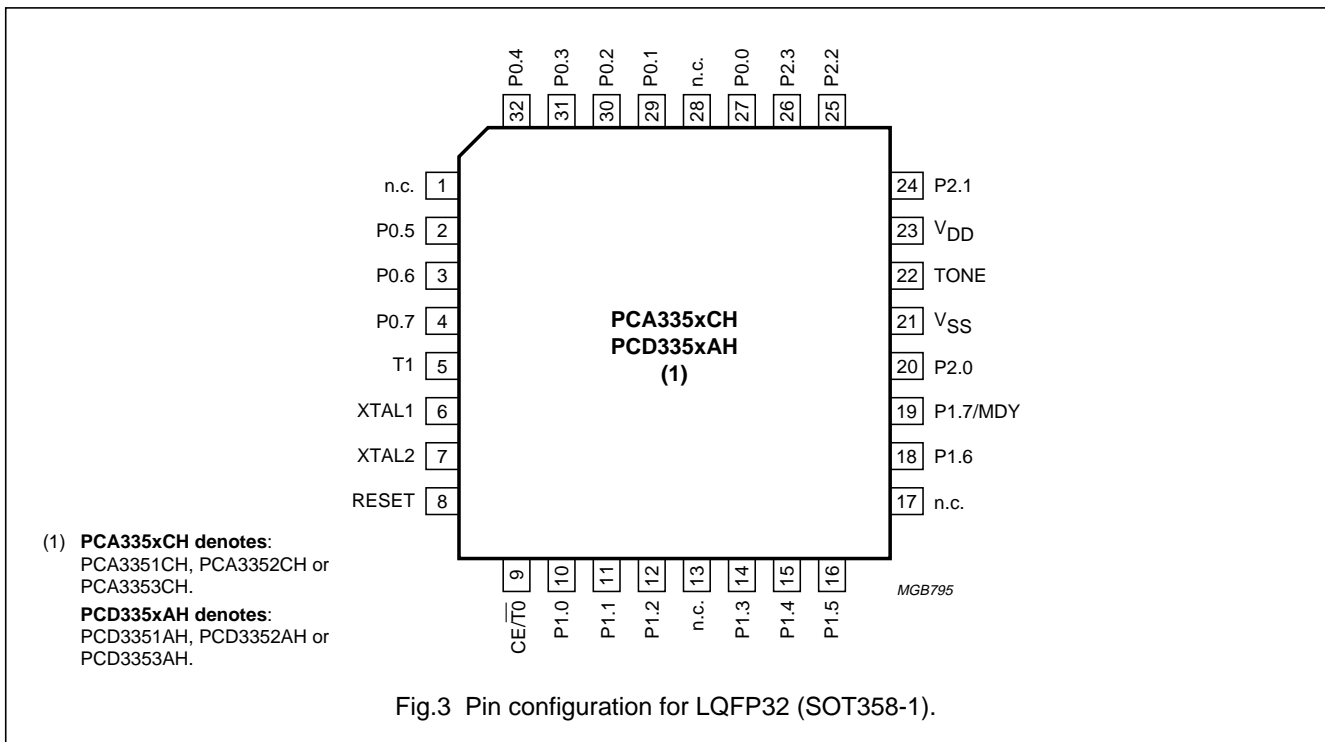
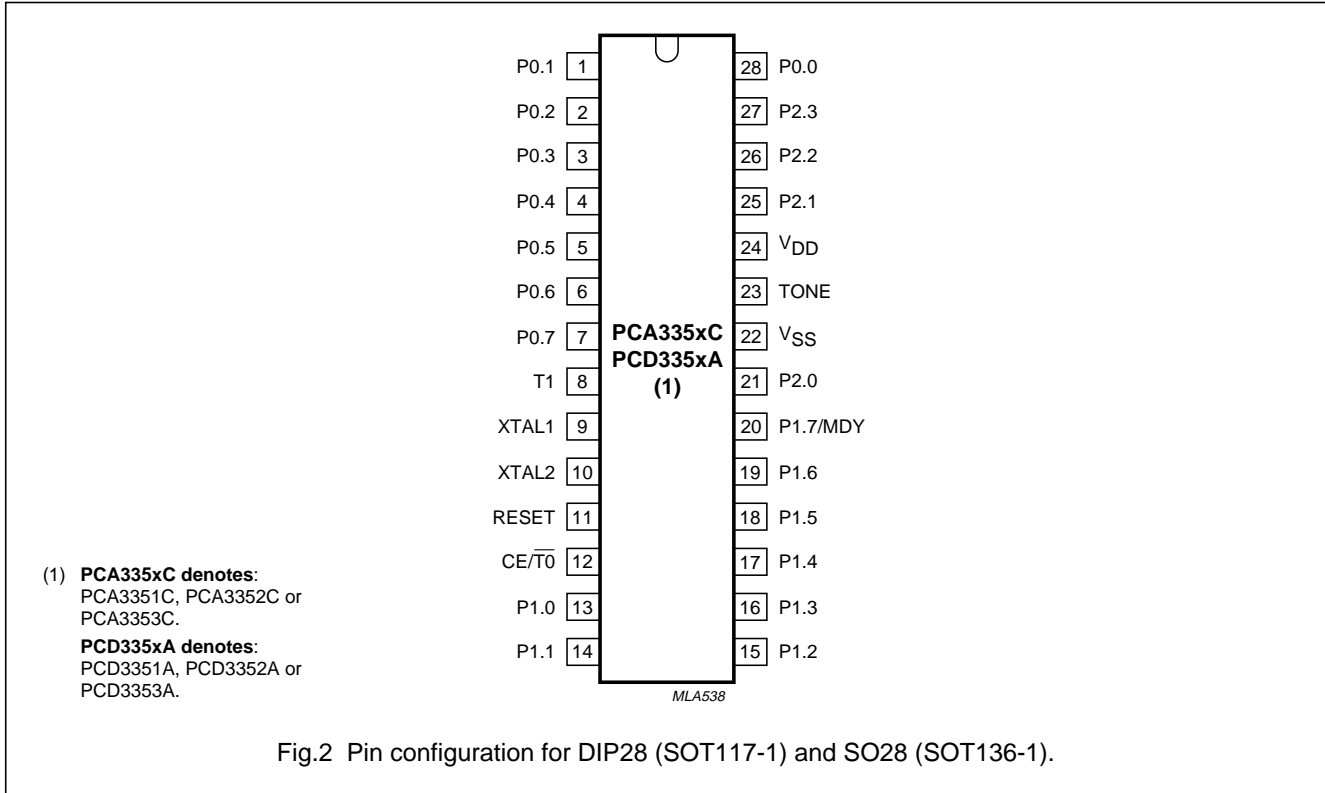

8-bit microcontrollers with DTMF generator and 128 bytes EEPROM

PCA3351C; 52C; 53C;
PCD3351A; 52A; 53A

5.2 Pin description

Table 2 SOT117-1 and SOT136-1 packages (for information on parallel I/O ports, see Chapter 14)

SYMBOL	PIN	TYPE	DESCRIPTION
P0.1 to P0.7	1 to 7	I/O	7 bits of Port 0: 8-bit quasi-bidirectional I/O port
T1	8	I	Test 1 or count input of 8-bit Timer/event counter 1
XTAL1	9	I	crystal oscillator or external clock input
XTAL2	10	O	crystal oscillator output
RESET	11	I	reset input
CE/ $\overline{T0}$	12	I	Chip Enable or Test 0
P1.0 to P1.6	13 to 19	I/O	7 bits of Port 1: 8-bit quasi-bidirectional I/O port
P1.7/MDY	20	I/O	1 bit of Port 1: 8-bit quasi-bidirectional I/O port; or melody output
P2.0	21	I/O	1 bit of Port 2: 4-bit quasi-bidirectional I/O port
V _{SS}	22	P	ground
TONE	23	O	DTMF output
V _{DD}	24	P	positive supply voltage
P2.1 to P2.3	25 to 27	I/O	3 bits of Port 2: 4-bit quasi-bidirectional I/O port
P0.0	28	I/O	1 bit of Port 0: 8-bit quasi-bidirectional I/O port

Table 3 SOT358-1 package (for information on parallel I/O ports, see Chapter 14)

SYMBOL	PIN	TYPE	DESCRIPTION
n.c.	1	–	not connected
P0.5 to P0.7	2 to 4	I/O	3 bits of Port 0: 8-bit quasi-bidirectional I/O port
T1	5	I	Test 1 or count input of 8-bit Timer/event counter 1
XTAL1	6	I	crystal oscillator or external clock input
XTAL2	7	O	crystal oscillator output
RESET	8	I	reset input
CE/ $\overline{T0}$	9	I	Chip Enable or Test 0
P1.0 to P1.2	10 to 12	I/O	3 bits of Port 1: 8-bit quasi-bidirectional I/O port
n.c.	13	–	not connected
P1.3 to P1.5	14 to 16	I/O	3 bits of Port 1: 8-bit quasi-bidirectional I/O port
n.c.	17	–	not connected
P1.6	18	I/O	1 bit of Port 1: 8-bit quasi-bidirectional I/O port
P1.7/MDY	19	I/O	1 bit of Port 1: 8-bit quasi-bidirectional I/O port; or melody output
P2.0	20	I/O	1 bit of Port 2: 4-bit quasi-bidirectional I/O port
V _{SS}	21	P	ground
TONE	22	O	DTMF output
V _{DD}	23	P	positive supply voltage
P2.1 to P2.3	24 to 26	I/O	3 bits of Port 2: 4-bit quasi-bidirectional I/O port
P0.0	27	I/O	1 bit of Port 0: 8-bit quasi-bidirectional I/O port
n.c.	28	–	not connected
P0.1 to P0.4	29 to 32	I/O	4 bits of Port 0: 8-bit quasi-bidirectional I/O port

8-bit microcontrollers with DTMF generator and 128 bytes EEPROM

PCA3351C; 52C; 53C;
PCD3351A; 52A; 53A

6 FREQUENCY GENERATOR

A versatile frequency generator section is provided (see Fig.4). For normal operation, use a 3.58 MHz quartz crystal or PXE resonator. The frequency generator includes precision circuitry for dual tone multifrequency (DTMF) signals, which is typically used for tone dialling telephone sets.

Their frequencies are provided in purely sinusoidal form on the TONE output or as square waves on the port line P1.7/MDY.

The TONE output can alternatively issue twelve modem frequencies for data rates between 300 and 1200 bits/s.

In addition to DTMF and modem frequencies, two octaves of musical scale in steps of semitones are available.

When no tones are generated the TONE output is in 3-state mode.

6.1 Frequency generator derivative registers

6.1.1 HIGH AND LOW GROUP FREQUENCY REGISTERS

Table 4 gives the addresses, symbols and access types of the High Group Frequency (HGF) and Low Group Frequency (LGF) registers.

Table 4 Hexadecimal addresses, symbols, access types and bit symbols of the frequency registers

REGISTER ADDRESS	REGISTER SYMBOL	ACCESS TYPE	BIT SYMBOLS							
			7	6	5	4	3	2	1	0
11H	HGF	W	H7	H6	H5	H4	H3	H2	H1	H0
12H	LGF	W	L7	L6	L5	L4	L3	L2	L1	L0

6.1.2 MELODY CONTROL REGISTER (MDYCON)

Table 5 Melody Control Register, MDYCON (address 13H; access type R/W)

7	6	5	4	3	2	1	0
0	0	0	0	0	0	0	EMO

Table 6 Description of MDYCON bits

BIT	SYMBOL	DESCRIPTION
7 to 1	–	These bits are set to a logic 0.
0	EMO	Enable Melody Output. If bit EMO = 0, then P1.7/MDY is a standard port line. If bit EMO = 1, then P1.7/MDY is the melody output. EMO = 1 does not inhibit the port instructions for P1.7/MDY. Therefore the state of both port line and flip-flop may be read in and the port flip-flop may be written by port instructions. However, the port flip-flop of P1.7/MDY must remain set to avoid conflicts between melody and port outputs. When the HGF contents are zero while EMO = 1, P1.7/MDY is in the HIGH state.

8-bit microcontrollers with DTMF generator
and 128 bytes EEPROM

PCA3351C; 52C; 53C;
PCD3351A; 52A; 53A

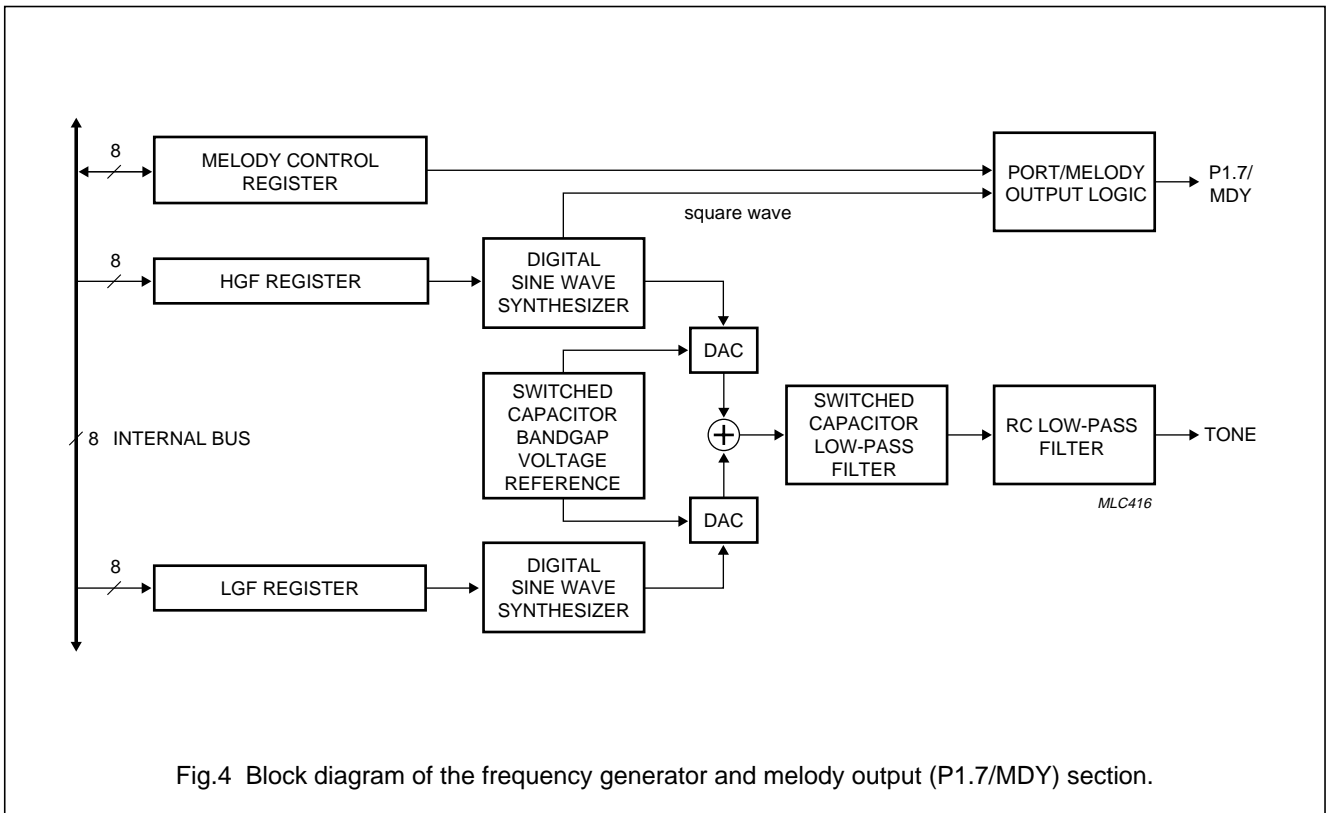

Fig.4 Block diagram of the frequency generator and melody output (P1.7/MDY) section.

8-bit microcontrollers with DTMF generator and 128 bytes EEPROM

PCA3351C; 52C; 53C; PCD3351A; 52A; 53A

6.2 Melody output (P1.7/MDY)

The melody output (P1.7/MDY) is very useful for generating musical notes when a purely sinusoidal signal is not required, such as for ringer applications.

The square wave (duty cycle = $\frac{12}{23}$ or 52%) will include the attenuated harmonics of the base frequency, which is defined by the contents of the HGF register (Table 4). However, even higher frequency notes may be produced since the low-pass filtering on the TONE output is not applied to the P1.7/MDY output. This results in the minimum decimal value x in the HGF register (see equation in Section 6.3) being 2 for the P1.7/MDY output, rather than 60 for the TONE output. A sinusoidal TONE output is produced at the same time as the melody square wave, but due to the filtering, the higher frequency sine waves with $x < 60$ will not appear at the TONE output.

Since the melody output is shared with P1.7, the port flip-flop of P1.7 has to be set HIGH before using the melody output. This to avoid conflicts between melody and port outputs. The melody output drive depends on the configuration of port P1.7/MDY, see Chapter 14, Table 26.

6.3 Frequency registers

The two frequency registers HGF and LGF define two frequencies. From these, the digital sine synthesizers together with the Digital-to-Analog Converters (DACs) construct two sine waves. Their amplitudes are precisely scaled according to the bandgap voltage reference. This ensures tone output levels independent of supply voltage and temperature.

The amplitude of the Low Group Frequency sine wave is attenuated by 2 dB compared to the amplitude of the High Group Frequency sine wave.

The two sine waves are summed and then filtered by an on-chip switched capacitor and RC low-pass filters. These guarantee that all DTMF tones generated fulfil the CEPT recommendations with respect to amplitude, frequency deviation, total harmonic distortion and suppression of unwanted frequency components.

The value 00H in a frequency register stops the corresponding digital sine synthesizer. If both frequency registers contain 00H, the whole frequency generator is shut off, resulting in lower power consumption.

The frequency of the sine wave generated from either HGF or LGF is a function of the decimal value 'x' held in the register. The variables are related by the equation:

$$f = \frac{f_{xtal}}{[23(x + 2)]}$$

where $60 \leq x \leq 255$ for TONE output.

6.4 DTMF frequencies

Assuming an oscillator frequency $f_{xtal} = 3.58$ MHz, the DTMF standard frequencies can be implemented as shown in Table 7.

The relationships between telephone keyboard symbols, DTMF frequency pairs and the frequency register contents are given in Table 8.

Table 7 DTMF standard frequencies and their implementation; value = LGF, HGF contents

VALUE (HEX)	FREQUENCY (Hz)		DEVIATION	
	STANDARD	GENERATED	(%)	(Hz)
DD	697	697.90	0.13	0.90
C8	770	770.46	0.06	0.46
B5	852	850.45	-0.18	-1.55
A3	941	943.23	0.24	2.23
7F	1209	1206.45	-0.21	-2.55
72	1336	1341.66	0.42	5.66
67	1477	1482.21	0.35	5.21
5D	1633	1638.24	0.32	5.24

Table 8 Dialling symbols, corresponding DTMF frequency pairs and frequency register contents

TELEPHONE KEYBOARD SYMBOLS	DTMF FREQ. PAIRS (Hz)	LGF VALUE (HEX)	HGF VALUE (HEX)
0	(941, 1336)	A3	72
1	(697, 1209)	DD	7F
2	(697, 1336)	DD	72
3	(697, 1477)	DD	67
4	(770, 1209)	C8	7F
5	(770, 1336)	C8	72
6	(770, 1477)	C8	67
7	(852, 1209)	B5	7F
8	(852, 1336)	B5	72
9	(852, 1477)	B5	67
A	(697, 1633)	DD	5D
B	(770, 1633)	C8	5D
C	(852, 1633)	B5	5D
D	(941, 1633)	A3	5D
•	(941, 1209)	A3	7F
#	(941, 1477)	A3	67

8-bit microcontrollers with DTMF generator and 128 bytes EEPROM

PCA3351C; 52C; 53C;
PCD3351A; 52A; 53A

6.5 Modem frequencies

Again assuming an oscillator frequency $f_{xtal} = 3.58$ MHz, the standard modem frequencies can be implemented as in Table 9. It is suggested to define the frequency by the HGF register while the LGF register contains 00H, disabling Low Group Frequency generation.

Table 9 Standard modem frequencies and their implementation

HGF VALUE (HEX)	FREQUENCY (Hz)		DEVIATION	
	MODEM	GENERATED	(%)	(Hz)
9D	980 ⁽¹⁾	978.82	-0.12	-1.18
82	1180 ⁽¹⁾	1179.03	-0.08	-0.97
8F	1070 ⁽²⁾	1073.33	0.31	3.33
79	1270 ⁽²⁾	1265.30	-0.37	-4.70
80	1200 ⁽³⁾	1197.17	-0.24	-2.83
45	2200 ⁽³⁾	2192.01	-0.36	-7.99
76	1300 ⁽⁴⁾	1296.94	-0.24	-3.06
48	2100 ⁽⁴⁾	2103.14	0.15	3.14
5C	1650 ⁽¹⁾	1655.66	0.34	5.66
52	1850 ⁽¹⁾	1852.77	0.15	2.77
4B	2025 ⁽²⁾	2021.20	-0.19	-3.80
44	2225 ⁽²⁾	2223.32	-0.08	-1.68

Notes

1. Standard is V.21.
2. Standard is Bell 103.
3. Standard is Bell 202.
4. Standard is V.23.

6.6 Musical scale frequencies

Finally, two octaves of musical scale in steps of semitones can be realized, again assuming an oscillator frequency $f_{xtal} = 3.58$ MHz (Table 10). It is suggested to define the frequency by the HGF register while the LGF contains 00H, disabling Low Group Frequency generation

Table 10 Musical scale frequencies and their implementation

NOTE	HGF VALUE (HEX)	FREQUENCY (Hz)	
		STANDARD ⁽¹⁾	GENERATED
D#5	F8	622.3	622.5
E5	EA	659.3	659.5
F5	DD	698.5	697.9
F#5	D0	740.0	741.1
G5	C5	784.0	782.1
G#5	B9	830.6	832.3
A5	AF	880.0	879.3
A#5	A5	923.3	931.9
B5	9C	987.8	985.0
C6	93	1046.5	1044.5
C#6	8A	1108.7	1111.7
D6	82	1174.7	1179.0
D#6	7B	1244.5	1245.1
E6	74	1318.5	1318.9
F6	6D	1396.9	1402.1
F#6	67	1480.0	1482.2
G6	61	1568.0	1572.0
G#6	5C	1661.2	1655.7
A6	56	1760.0	1768.5
A#6	51	1864.7	1875.1
B6	4D	1975.5	1970.0
C7	48	2093.0	2103.3
C#7	44	2217.5	2223.3
D7	40	2349.3	2358.1
D#7	3D	2489.0	2470.4

Note

1. Standard scale based on A4 @ 440 Hz.

**8-bit microcontrollers with DTMF generator
and 128 bytes EEPROM**

**PCA3351C; 52C; 53C;
PCD3351A; 52A; 53A**

7 EEPROM AND TIMER 2 ORGANIZATION

The PCD335xA and PCA335xC have 128 bytes of Electrically Erasable Programmable Read-Only Memory (EEPROM). Such non-volatile storage provides data retention without the need for battery backup. In telecom applications, the EEPROM is used for storing redial numbers and for short dialling of frequently used numbers. More generally, EEPROM may be used for customizing microcontrollers, such as to include a PIN code or a country code, to define trimming parameters, to select application features from the range stored in ROM.

The most significant difference between a RAM and an EEPROM is that a bit in EEPROM, once written to a logic 1, cannot be cleared by a subsequent write operation. Successive write accesses actually perform a logical OR with the previously stored information. Therefore, to clear a bit, the whole byte must be erased and re-written with the particular bit cleared. Thus, an erase-and-write operation is the EEPROM equivalent of a RAM write operation

Whereas read access times to an EEPROM are comparable to RAM access times, write and erase access times are much slower at 5 ms each. To make these operations more efficient, several provisions are available in the PCD335xA and PCA335xC.

First, the EEPROM array is structured into 32 four-byte pages (see Fig.5) permitting access to 4 bytes in parallel (write page, erase/write page and erase page). It is also possible to erase and write individual bytes. Finally, the EEPROM address register provides auto-incrementing, allowing very efficient read and write accesses to sequential bytes.

To simplify the erase and write timing, the derivative 8-bit down-counter (Timer 2) with reload register is provided. In addition to EEPROM timing, Timer 2 can be used for general real-time tasks, such as for measuring signal duration and for defining pulse widths.

8-bit microcontrollers with DTMF generator
and 128 bytes EEPROM

PCA3351C; 52C; 53C;
PCD3351A; 52A; 53A

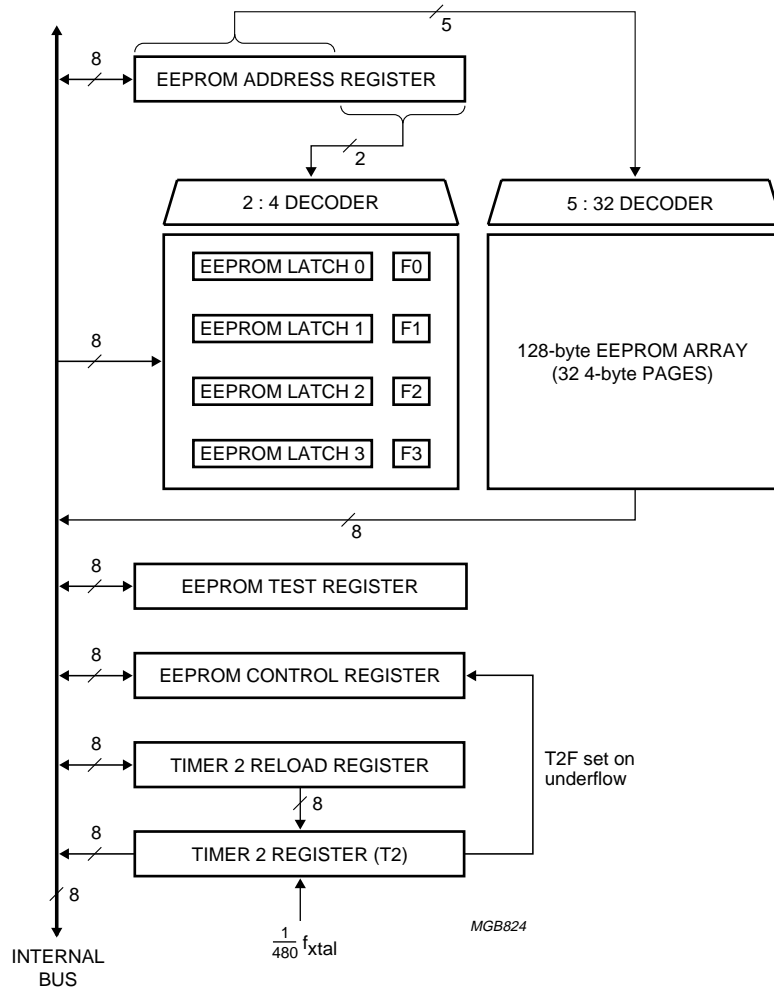

Fig.5 Block diagram of the EEPROM and Timer 2.

8-bit microcontrollers with DTMF generator and 128 bytes EEPROM

PCA3351C; 52C; 53C;
PCD3351A; 52A; 53A

7.1 EEPROM registers

7.1.1 EEPROM CONTROL REGISTER (EPCR)

The behaviour of the EEPROM and Timer 2 section is defined by the EEPROM Control Register. See Tables 11, 12 and 13.

Table 11 EEPROM Control Register, EPCR (address 04H, access type R/W)

7	6	5	4	3	2	1	0
STT2	ET2I	T2F	EWP	MC3	MC2	MC1	0

Table 12 Description of the EPCR bits

BIT	SYMBOL	DESCRIPTION
7	STT2	Start T2. If STT2 = 0, then Timer 2 is stopped; T2 value held. If STT2 = 1, then T2 decrements from reload value.
6	ET2I	Enable T2 interrupt. If ET2I = 0, then T2F event cannot request interrupt. If ET2I = 1, then T2F event can request interrupt.
5	T2F	Timer 2 flag. Set when T2 underflows (or by program); reset by program.
4	EWP	Erase or write in progress (EWP). Set by program (EWP starts EEPROM erase and/or write and Timer 2). Reset at the end of EEPROM erase and/or write.
3	MC3	Mode control 3 to 1. These three bits in conjunction with bit EWP select the mode as shown in Table 13.
2	MC2	
1	MC1	
0	–	This bit is set to a logic 0.

Table 13 Mode selection; X = don't care

EWP	MC3	MC2	MC1	DESCRIPTION
0	0	0	0	read byte
0	0	1	0	increment mode
1	0	1	X	write page
1	1	0	0	erase/write page
1	1	1	1	erase page
X	0	0	1	not allowed
X	1	0	1	
X	1	1	0	

8-bit microcontrollers with DTMF generator and 128 bytes EEPROM

PCA3351C; 52C; 53C;
PCD3351A; 52A; 53A

7.1.2 EEPROM ADDRESS REGISTER (ADDR)

The EEPROM Address Register determines the EEPROM location to which an EEPROM access is directed.

As a whole, ADDR auto-increments after read and write cycles to EEPROM, but remains fixed after erase cycles. This behaviour generates the correct ADDR contents for sequential read accesses and for sequential write or erase/write accesses with intermediate page setup. Overflow of the 8-bit counter wraps around to zero.

Table 14 EEPROM Address Register, ADDR (address 01H, access type R/W)

7	6	5	4	3	2	1	0
0	AD6	AD5	AD4	AD3	AD2	AD1	AD0

Table 15 Description of ADDR bits

BIT	SYMBOL	DESCRIPTION
7	–	This bit is set to a logic 0.
6 to 2	AD6 to AD2	AD2 to AD6 select one of 32 pages.
1 to 0	AD1 to AD0	AD1 and AD0 are irrelevant during erase and write cycles. For read accesses, AD0 and AD1 indicate the byte location within an EEPROM page. During page setup, finally, AD0 and AD1 select EEPROM Latch 0 to 3 whereas AD2 to AD6 are irrelevant. If increment mode (Table 13) is active during page setup, the subcounter consisting of AD0 and AD1 increments after every write to an EEPROM latch, thus enhancing access to sequential EEPROM latches. Incrementing stops when EEPROM Latch 3 is reached, i.e. when AD0 and AD1 are both a logic 1.

7.1.3 EEPROM DATA REGISTER (DATR)

Table 16 EEPROM Data Register, DATR (address 03H; access type R/W)

7	6	5	4	3	2	1	0
D7	D6	D5	D4	D3	D2	D1	D0

Table 17 Description of DATR bits

BIT	SYMBOL	DESCRIPTION
7 to 0	D7 to D0	The EEPROM Data Register (DATR) is only a conceptual entity. A read operation from DATR, reads out the EEPROM byte addressed by ADDR. On the other hand, a write operation to DATR, loads data into the EEPROM latch (see Fig.5) defined by bits AD0 and AD1 of ADDR.

7.1.4 EEPROM TEST REGISTER (TST)

The EEPROM Test register is used for testing purposes during device manufacture. It must not be accessed by the device user.

8-bit microcontrollers with DTMF generator and 128 bytes EEPROM

PCA3351C; 52C; 53C;
PCD3351A; 52A; 53A

7.2 EEPROM latches

The four EEPROM latches (EEPROM Latch 0 to 3; Fig.5) cannot be read by user software. Due to their construction, the latches can only be preset, but not cleared. Successive write operations through DATR to the EEPROM latches actually perform a logical OR with the previously stored data in EEPROM. The EEPROM latches are reset at the conclusion of any EEPROM cycle.

7.3 EEPROM flags

The four EEPROM flags (F0 to F3; Fig.5) cannot be directly accessed by user software. An EEPROM flag is set as a side-effect when the corresponding EEPROM latch is written through DATR. The EEPROM flags are reset at the conclusion of any EEPROM cycle.

7.4 EEPROM macros

The instruction sequence used in an EEPROM access should be treated as an indivisible entity. Erroneous programs result if ADDR, DATR, RELR or EPCR are inadvertently changed during an EEPROM cycle or its setup. Special care should be taken if the program may asynchronously divert due to an interrupt. A new access to the EEPROM may only be initiated when no write, erase or erase/write cycles are in progress. This can be verified by reading bit EWP (register EPCR).

For write, erase and erase/write cycles, it is assumed that the Timer 2 Reload Register (RELR) has been loaded with the appropriate value for a 5 ms delay, which depends on f_{xtal} (see Table 24). The end of a write, erase or erase/write cycle will be signalled by a cleared EWP and by a Timer 2 interrupt provided that ET2I = 1 and that the derivative interrupt is enabled.

7.5 EEPROM access

One read, one write, one erase/write and one erase access are defined by bits EWP and MC1 to MC3 in the EPCR register; see Table 11.

Read byte retrieves the EEPROM byte addressed by ADDR when DATR is read. Read cycles are instantaneous.

Write and erase cycles take 5 ms, however. Erase/write is a combination of an erase and a subsequent write cycle, consequently taking 10 ms.

As their names imply, **write page, erase page and erase/write page** are applied to a whole EEPROM page. Therefore, bits AD0 and AD1 of register ADDR (see Table 14), defining the byte location within an EEPROM page, are irrelevant during write and erase cycles.

However, write and erase cycles need not affect all bytes of the page. The EEPROM flags F0 to F3 (see Fig.5) determine which bytes within the EEPROM page are affected by the erase and/or write cycles. A byte whose corresponding EEPROM flag is zero remains unchanged.

With erase page, a byte is erased if its corresponding EEPROM flag is set. With write page, data in EEPROM Latch 0 to 3 (Fig.5) are ORed to the individual page bytes if and only if the corresponding EEPROM flags are set.

In an erase/write cycle, F0 to F3 select which page bytes are erased and ORed with the corresponding EEPROM latches.

ORing, in this event, means that the EEPROM latches are copied to the selected page bytes.

The described page-wise organization of erase and write cycles allows up to four bytes to be individually erased or written within 5 ms. This advantage necessitates a preparation step, called **page setup**, before the actual erase and/or write cycle can be executed.

Page setup controls EEPROM latches and EEPROM flags. This will be described in the Sections 7.5.1 to 7.5.5.

7.5.1 PAGE SETUP

Page setup is a preparation step required before write page, erase page and erase/write page cycles.

As previously described, these page operations include single-byte write, erase and erase/write as a special event. EEPROM flags F0 to F3 determine which page bytes will be affected by the mentioned page operations. EEPROM Latch 0 to 3 must be preset through DATR to specify the write cycle data to EEPROM and to set the EEPROM flags as a side-effect. Obviously, the actual preset value of the EEPROM latches is irrelevant for erase page. Preset of one, two, three or all four EEPROM latches and the corresponding EEPROM flags can be performed by repeatedly defining ADDR and writing to DATR (see Table 18).

If more than one EEPROM latch must be preset, the subcounter consisting of AD0 and AD1 can be induced to auto-increment after every write to DATR, thus stepping through all EEPROM latches. For this purpose, increment mode (Table 13) must be selected. Auto-incrementing stops at EEPROM Latch 3. It is not mandatory to start at EEPROM Latch 0 as in shown in Table 19.

Note that AD2 to AD6 are irrelevant during page setup. They will usually specify the intended EEPROM page, anticipating the subsequent page cycle.

8-bit microcontrollers with DTMF generator and 128 bytes EEPROM

PCA3351C; 52C; 53C;
PCD3351A; 52A; 53A

From now on, it will be assumed that AD2 to AD6 will contain the intended EEPROM page address after page setup.

Table 18 Page setup; preset

INSTRUCTION	RESULT
MOV A, #addr	address of EEPROM latch
MOV ADDR, A	send address to ADDR
MOV A, #data	load write, erase/write or erase data
MOV DATR, A	send data to addressed EEPROM latch

Table 19 Page setup; auto-incrementing

INSTRUCTION	RESULT
MOV A, #MC2	increment mode control word
MOV EPCR, A	select increment mode
MOV A, #baddr	EEPROM Latch 0 address (AD0 = AD1 = 0)
MOV ADDR, A	send EEPROM Latch 0 address to ADDR
MOV A, R0	load 1 st byte from Register 0
MOV DATR, A	send 1 st byte to EEPROM Latch 0
MOV A, R1	load 2 nd byte from Register 1
MOV DATR, A	send 2 nd byte to EEPROM Latch 1
MOV A, R2	load 3 rd byte from Register 2
MOV DATR, A	send 3 rd byte to EEPROM Latch 2
MOV A, R3	load 4 th byte from Register 3
MOV DATR, A	send 4 th byte to EEPROM Latch 3

7.5.2 READ BYTE

Since ADDR auto-increments after a read cycle regardless of the page boundary, successive bytes can efficiently be read by repeating the last instruction.

Table 20 Read byte

INSTRUCTION	RESULT
MOV A, #RDADDR	load read address
MOV ADDR, A	send address to ADDR
MOV A, DATR	read EEPROM data

7.5.3 WRITE PAGE

The write cycle performs a logical OR between the data in the EEPROM latches and that in the addressed EEPROM page. To actually copy the data from the EEPROM

latches, the corresponding bytes in the page should previously have been erased.

The EEPROM latches are preset as described in Section 7.5.1. The actual transfer to the EEPROM is then performed as shown in Table 21.

The last instruction also starts Timer 2. The data in the EEPROM latches are ORed with that in the corresponding page bytes within 5 ms. A single-byte write is simply a special case of 'write page'.

ADDR auto-increments after the write cycle. If AD0 and AD1 addressed EEPROM Latch 3 prior to the write cycle, ADDR will point to the next EEPROM page (by bits AD2 to AD6) and to EEPROM Latch 0 (by bits AD0 and AD1). This allows efficient coding of multi-page write operations.

Table 21 Write page

INSTRUCTION	RESULT
MOV A, #EWP + MC2	'write page' control word
MOV EPCR, A	start 'write page' cycle

7.5.4 ERASE/WRITE PAGE

The EEPROM latches are preset as described in Section 7.5.1. The page bytes corresponding to the asserted flags (among F0 to F3) are erased and re-written with the contents of the respective EEPROM latches.

The last instruction also starts Timer 2. Erasure takes 5 ms upon which Timer Register T2 reloads for another 5 ms cycle for writing. The top cycles together take 10 ms. A single-byte erase/write is simply a special case of 'erase/write page'.

ADDR auto-increments after the write cycle. If AD0 and AD1 addressed EEPROM Latch 3 prior to the write cycle, ADDR will point to the next EEPROM page (by AD2 to AD6) and to EEPROM Latch 0 (by AD0 and AD1). This allows efficient coding of multi-page erase/write operations.

Table 22 Erase/write page

INSTRUCTION	RESULT
MOV A, #EWP + MC3	'erase/write page' control word
MOV EPCR, A	start 'erase/write page' cycle

8-bit microcontrollers with DTMF generator and 128 bytes EEPROM

PCA3351C; 52C; 53C;
PCD3351A; 52A; 53A

7.5.5 ERASE PAGE

The EEPROM flags are set as described in Section 7.5.1. The corresponding page bytes are erased.

The last instruction also starts Timer 2. Erasure takes 5 ms. A single-byte erase is simply a special case of 'erase page'.

Note that ADDR does not auto-increment after an erase cycle.

Table 23 Erase page

INSTRUCTION	RESULT
MOV A, #EWP + MC3 + MC2 + MC1	'erase page' control word
MOV EPCR, A	start 'erase page' cycle

7.6 Timer 2

Timer 2 is a 8-bit down-counter decremented at a rate of $\frac{1}{480} \times f_{xtal}$. It may be used either for EEPROM timing or as a general purpose timer. Conflicts between the two applications should be carefully avoided.

7.6.1 TIMER 2 FOR EEPROM TIMING

When used for EEPROM timing, Timer 2 serves to generate the 5 ms intervals needed for erasing or writing the EEPROM. At the decrement rate of $\frac{1}{480} \times f_{xtal}$, the reload value for a 5 ms interval is a function of f_{xtal} . Table 24 summarizes the required reload values for a number of oscillator frequencies.

Timer 2 is started by setting bit EWP in the EPCR. The Timer Register T2 is loaded with the reload value from RELR. T2 decrements to zero.

For an erase/write cycle, underflow of T2 indicates the end of the erase operation. Therefore, Timer Register T2 is reloaded from RELR for another 5 ms interval during which the flagged EEPROM latches are copied to the corresponding bytes in the page addressed by ADDR.

The second underflow of an erase/write cycle and the first underflow of write page and erase page conclude the corresponding EEPROM cycle. Timer 2 is stopped, T2F is set whereas EWP and MC1 to MC3 are cleared.

Table 24 Reload values as a function of f_{xtal}

f_{xtal} (MHz)	RELOAD VALUE ⁽¹⁾ (HEX)
1	0A
2	14
3.58	25
6	3E
10	68
16	A6

Note

- The reload value is $(5 \times 10^{-3} \times \frac{1}{480} \times f_{xtal}) - 1$; f_{xtal} in MHz.

7.6.2 TIMER 2 AS A GENERAL PURPOSE TIMER

When used for purposes other than EEPROM timing, Timer 2 is started by setting STT2. The Timer Register T2 (see Table 27) is loaded with the reload value from RELR. T2 decrements to zero. On underflow, T2 is reloaded from RELR, T2F is set and T2 continues to decrement.

Timer 2 can be stopped at any time by clearing STT2. The value of T2 is then held and can be read out. After setting STT2 again, Timer 2 decrements from the reload value. Alternatively, it is possible to read T2 'on the fly' i.e. while Timer 2 is operating.

8-bit microcontrollers with DTMF generator and 128 bytes EEPROM

PCA3351C; 52C; 53C;
PCD3351A; 52A; 53A

8 DERIVATIVE INTERRUPTS

One derivative interrupt event is defined. It is controlled by bits T2F and ET2I in the EPCR (see Tables 11 and 12).

The derivative interrupt event occurs when T2F is set. This request is honoured under the following circumstances:

- No interrupt routine proceeds
- No external interrupt request is pending
- The derivative interrupt is enabled
- ET2I is set.

The derivative interrupt routine must include instructions that will remove the cause of the derivative interrupt by explicitly clearing T2F. If the derivative interrupt is not used, T2F may directly be tested by the program. Obviously, T2F can also be asserted under program control, e.g. to generate a software interrupt.

9 TIMING

Although the PCD335xA and PCA335xC operate over a clock frequency range from 1 to 16 MHz, $f_{\text{xtal}} = 3.58$ MHz will usually be chosen to take full advantage of the frequency generator section.

10 RESET

In addition to the conditions given in the “PCD33XXA Family” data sheet, all derivative registers are cleared in the reset state.

11 IDLE MODE

In Idle mode, the frequency generator, the EEPROM and the Timer 2 sections remain operative. Therefore, the IDLE instruction may be executed while an erase and/or write access to EEPROM is in progress.

12 STOP MODE

Since the oscillator is switched off, the frequency generator, the EEPROM and the Timer 2 sections receive no clock. It is suggested to clear both the HGF and the LGF registers before entering Stop mode. This will cut off the biasing of the internal amplifiers, considerably reducing current requirements.

The Stop mode **must not** be entered while an erase and/or write access to EEPROM is in progress. The STOP instruction may only be executed when EWP in EPCR is zero. The Timer 2 section is frozen during Stop mode.

After exit from Stop mode by a HIGH level on $\overline{\text{CE/T0}}$, Timer 2 proceeds from the held state.

13 INSTRUCTION SET RESTRICTIONS

- For PCD3351A and PCA3351C only:
 - ROM space being restricted to 2 kbytes, the ‘SEL MB1/2/3’ instructions would define non-existing program memory banks and should therefore be avoided.
 - RAM space being restricted to 64 bytes, care should be taken to avoid accesses to non-existing RAM locations.
- For PCD3352A and PCA3352C only:
 - ROM space being restricted to 4 kbytes, the ‘SEL MB2/3’ instructions would define non-existing program memory banks and should therefore be avoided.
- For PCD3353A and PCA3353C only:
 - ROM space being restricted to 6 kbytes, the ‘SEL MB3’ instructions would define non-existing program memory banks and should therefore be avoided.
- For the PCD3352A, PCD3353A, PCA3352C and PCA3353C, RAM space is restricted to 128 bytes, thus care should be taken to avoid accesses to non-existing RAM locations.

8-bit microcontrollers with DTMF generator and 128 bytes EEPROM

PCA3351C; 52C; 53C;
PCD3351A; 52A; 53A

14 OVERVIEW OF PORT AND POWER-ON-RESET CONFIGURATIONS

- The PCA335xC microcontrollers support one port and Power-on-reset configuration which is compatible with the OTP PCD3755E.
- The PCD335xA microcontrollers support two port and Power-on-reset configurations which can be chosen: one is compatible with the OTP PCD3755A, the other is compatible with the OTP PCD3755E.

Table 25 Available mask configurations

TYPE	CONFIGURATION	
	PCD3755A	PCD3755E
PCA3351C	–	X
PCA3352C	–	X
PCA3353C	–	X
PCD3351A	X	X
PCD3352A	X	X
PCD3353A	X	X

Table 26 Port and Power-on-Reset configurations

See note 1 and 2.

COVERED BY OTP	PORT 0								PORT 1								PORT 2				V _{POR}
	0	1	2	3	4	5	6	7	0	1	2	3	4	5	6	7	0	1	2	3	
PCD3755A	1S	1S	1S	1S	1S	1S	1S	1S	1S	1S	1S	1S	1S	1S	1R	1R ⁽³⁾	2S	2S	2S	2S	1.3 V
PCD3755E	1S	1S	1S	1S	1S	1S	1S	1S	2S	2S	2S	2S	2S	2S	1S	1S ⁽³⁾	2S	1R	1R	1R	2.0 V

Notes

1. Port output drive: 1 = standard I/O; 2 = open-drain I/O, see “PCD33xxA Family” data sheet.
2. Port state after reset: S = Set (HIGH) and R = Reset (LOW).
3. The melody output drive type is push-pull.

8-bit microcontrollers with DTMF generator and 128 bytes EEPROM

PCA3351C; 52C; 53C;
PCD3351A; 52A; 53A

15 SUMMARY OF DERIVATIVE REGISTERS

Table 27 Register map

ADDR. (HEX)	REGISTER	7	6	5	4	3	2	1	0	R/W
00	not used									
01	EEPROM Address Register (ADDR)	0	AD6	AD5	AD4	AD3	AD2	AD1	AD0	R/W
02	not used									
03	EEPROM Data Register (DATR)	D7	D6	D5	D4	D3	D2	D1	D0	R/W
04	EEPROM Control Register (EPCR)	STT2	ET21	TF2	EWP	MC3	MC2	MC1	0	R/W
05	Timer 2 Reload Register (RELR)	R7	R6	R5	R4	R3	R2	R1	R0	R/W
06	Timer 2 Register (T2)	T2.7	T2.6	T2.5	T2.4	T2.3	T2.2	T2.1	T2.0	R
07	Test Register (TST)	only for test purposes; not to be accessed by the device user								
08 to 10	not used									
11	High Group Frequency Register (HGF)	H7	H6	H5	H4	H3	H2	H1	H0	W
12	Low Group Frequency Register (LGF)	L7	L6	L5	L4	L3	L2	L1	L0	W
13	Melody Control Register (MDYCON)	0	0	0	0	0	0	0	EMO	R/W
14 to FF	not used									

16 HANDLING

Inputs and outputs are protected against electrostatic discharge in normal handling. However, it is good practice to take normal precautions appropriate to handling MOS devices (see "Data Handbook IC14, Section: Handling MOS devices").

17 LIMITING VALUES

In accordance with the Absolute Maximum Rating System (IEC 134).

SYMBOL	PARAMETER	MIN.	MAX.	UNIT
V_{DD}	supply voltage	-0.8	+7.0	V
V_I	all input voltages	-0.5	$V_{DD} + 0.5$	V
I_I	DC input current	-10	+10	mA
I_O	DC output current	-10	+10	mA
P_{tot}	total power dissipation	-	125	mW
P_O	power dissipation per output	-	30	mW
I_{SS}	ground supply current	-50	+50	mA
T_{stg}	storage temperature	-65	+150	°C
T_j	operating junction temperature	-	90	°C

8-bit microcontrollers with DTMF generator and 128 bytes EEPROM

PCA3351C; 52C; 53C;
PCD3351A; 52A; 53A

18 DC CHARACTERISTICS

$V_{DD} = 1.8$ to 6 V; $V_{SS} = 0$ V; $T_{amb} = 0$ to $+50$ °C (PCA335xC) or -25 to $+70$ °C (PCD335xA); all voltages with respect to V_{SS} ; $f_{xtal} = 3.58$ MHz; unless otherwise specified.

SYMBOL	PARAMETER	CONDITIONS	MIN.	TYP.	MAX.	UNIT
Supply						
V_{DD}	supply voltage	see Fig.6	1.8	–	6	V
	operating RAM data retention in Stop mode	note 1	1.0	–	6	V
I_{DD}	operating supply current	see Figs 7 and 8; note 2	–	0.8	1.6	mA
		$V_{DD} = 3$ V; value HGF or LGF $\neq 0$	–	0.35	0.7	mA
		$V_{DD} = 3$ V	–	1.5	4.0	mA
		$V_{DD} = 5$ V; $f_{xtal} = 10$ MHz	–	2.4	6.0	mA
$I_{DD(idle)}$	supply current (Idle mode)	see Figs 9 and 10; note 2	–	0.7	1.4	mA
		$V_{DD} = 3$ V; value HGF or LGF $\neq 0$	–	0.25	0.5	mA
		$V_{DD} = 3$ V	–	1.1	3.4	mA
		$V_{DD} = 5$ V; $f_{xtal} = 10$ MHz	–	1.7	5.0	mA
$I_{DD(stp)}$	supply current (Stop mode)	see Fig.11; note 3	–	1.0	5.5	μ A
		$V_{DD} = 1.8$ V; $T_{amb} = 25$ °C; $V_{DD} = 1.8$ V; $T_{amb} = 70$ °C;	–	–	10	μ A
Inputs						
V_{IL}	LOW level input voltage		0	–	$0.3V_{DD}$	V
V_{IH}	HIGH level input voltage		$0.7V_{DD}$	–	V_{DD}	V
I_{LI}	input leakage current	$V_{SS} \leq V_I \leq V_{DD}$	–1	–	1	μ A
Port outputs						
I_{OL}	LOW level port sink current	$V_{DD} = 3$ V; $V_O = 0.4$ V; see Fig.12	0.7	3.5	–	mA
I_{OH}	HIGH level pull-up output source current	$V_{DD} = 3$ V; $V_O = 2.7$ V; see Fig.13	–10	–30	–	μ A
		$V_{DD} = 3$ V; $V_O = 0$ V; see Fig.13	–	–140	–300	μ A
I_{OH1}	HIGH level push-pull output source current	$V_{DD} = 3$ V; $V_O = 2.6$ V; see Fig.14	–0.7	–3.5	–	mA
Tone output (see Fig.15)						
$V_{HG(RMS)}$	HGF voltage (RMS value)		158	181	205	mV
$V_{LG(RMS)}$	LGF voltage (RMS value)		125	142	160	mV
$\Delta f/f$	frequency deviation		–0.6	–	0.6	%
V_{DC}	DC voltage level		–	$0.5V_{DD}$	–	V
$ Z_o $	output impedance		–	100	500	Ω
G_v	pre-emphasis of group		1.5	2.0	2.5	dB
THD	total harmonic distortion	$T_{amb} = 25$ °C; note 5	–	25	–	dB

**8-bit microcontrollers with DTMF generator
and 128 bytes EEPROM**
**PCA3351C; 52C; 53C;
PCD3351A; 52A; 53A**

SYMBOL	PARAMETER	CONDITIONS	MIN.	TYP.	MAX.	UNIT
EEPROM (notes 1 and 6)						
$CY_{t/w}$	endurance (erase/write cycles)	note 7	10^5	–	–	
t_{ret}	data retention time		10	–	–	years
Power-on-reset (see Fig.16)						
V_{POR}	Power-on-reset level					
	PCD335xA	configuration as PCD3755A	0.8	1.3	1.8	V
	PCD335xA	configuration as PCD3755E	1.5	2.0	2.5	V
	PCA335xC	configuration as PCD3755E	1.7 ⁽⁸⁾	2.0	2.3	V
Oscillator (see Fig.17)						
g_m	transconductance	$V_{DD} = 5\text{ V}$	0.2	0.4	1.0	mS
R_F	feedback resistor		0.3	1.0	3.0	M Ω

Notes

- TONE output, EEPROM erase and write require $V_{DD} \geq 2.5\text{ V}$.
- $V_{IL} = V_{SS}$; $V_{IH} = V_{DD}$; open-drain outputs connected to V_{SS} ; all other outputs open; value HGF = LGF = 0, unless otherwise specified.
 - Maximum values: external clock at XTAL1 and XTAL2 open-circuit.
 - Typical values: $T_{amb} = 25\text{ }^\circ\text{C}$; crystal connected between XTAL1 and XTAL2.
- $V_{IL} = V_{SS}$; $V_{IH} = V_{DD}$; RESET, T1 and CE/T0 at V_{SS} ; crystal connected between XTAL1 and XTAL2; pins T1 and CE/T0 at V_{SS} .
- Values are specified for DTMF frequencies only (CEPT).
- Related to the Low Group Frequency (LGF) component (CEPT).
- After final testing the value of each EEPROM bit is a logic 1, but this cannot be guaranteed after board assembly.
- Verified on sampling basis.
- Each device is tested on the condition: $V_{DD(min)} < V_{POR}$; to ensure a correct start-up, even for slow rising supply voltages.

8-bit microcontrollers with DTMF generator and 128 bytes EEPROM

PCA3351C; 52C; 53C; PCD3351A; 52A; 53A

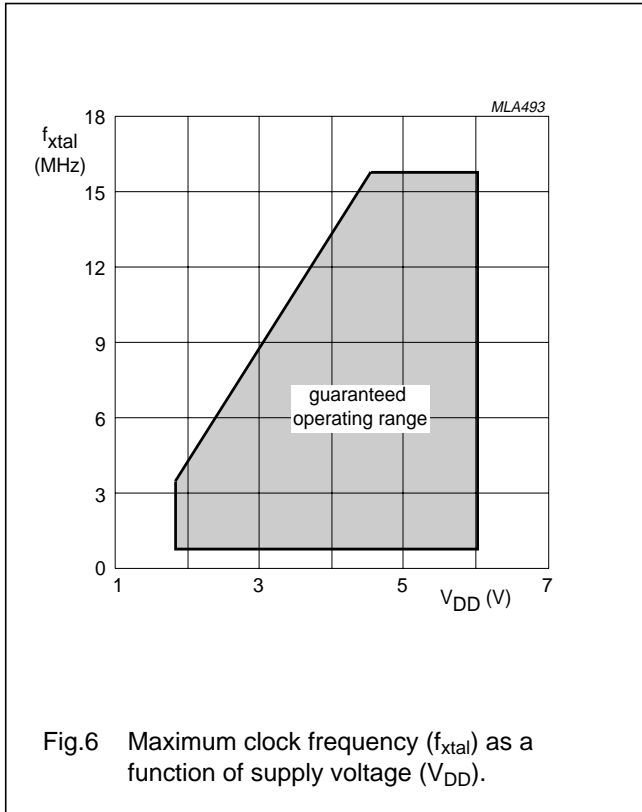

Fig.6 Maximum clock frequency (f_{xtal}) as a function of supply voltage (V_{DD}).

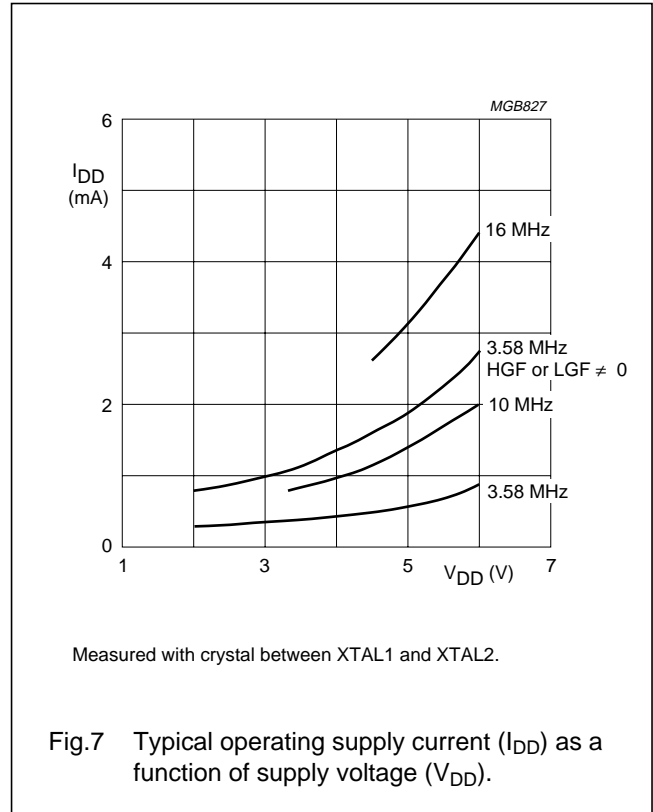
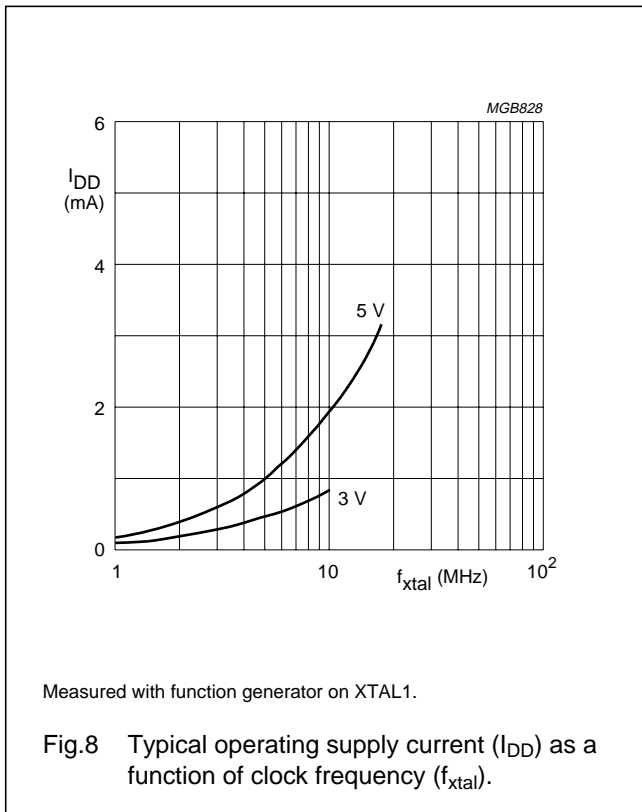
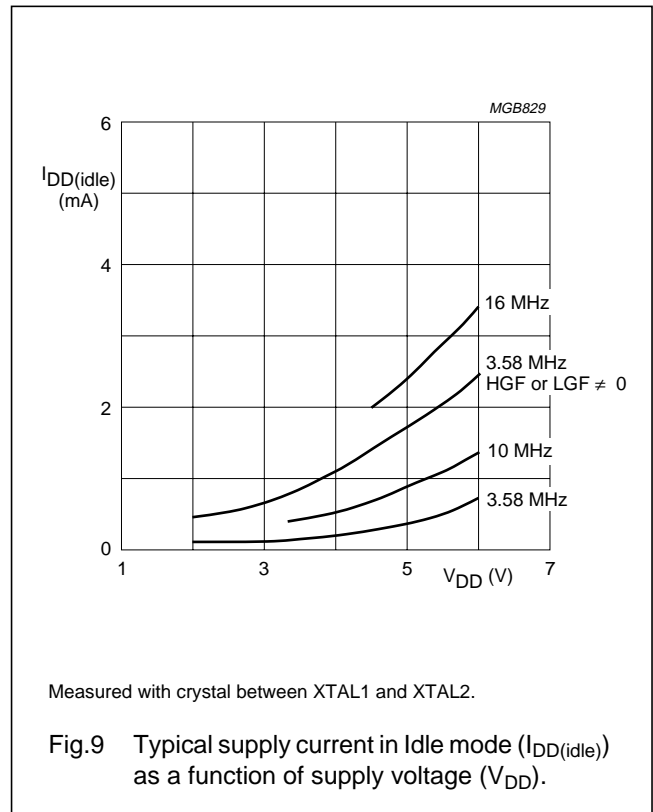

Fig.7 Typical operating supply current (I_{DD}) as a function of supply voltage (V_{DD}).



Measured with function generator on XTAL1.
Fig.8 Typical operating supply current (I_{DD}) as a function of clock frequency (f_{xtal}).



Measured with crystal between XTAL1 and XTAL2.
Fig.9 Typical supply current in Idle mode ($I_{DD(idle)}$) as a function of supply voltage (V_{DD}).

8-bit microcontrollers with DTMF generator and 128 bytes EEPROM

PCA3351C; 52C; 53C; PCD3351A; 52A; 53A

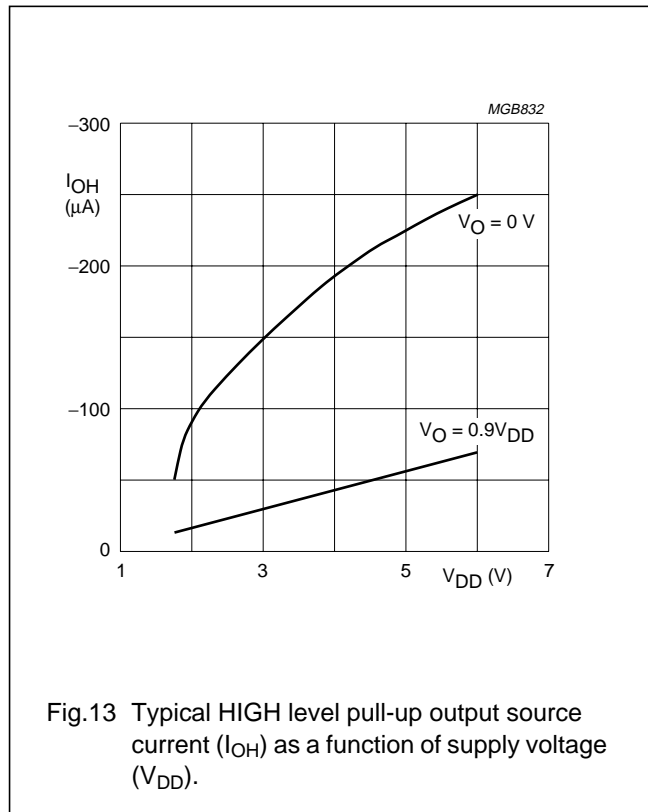
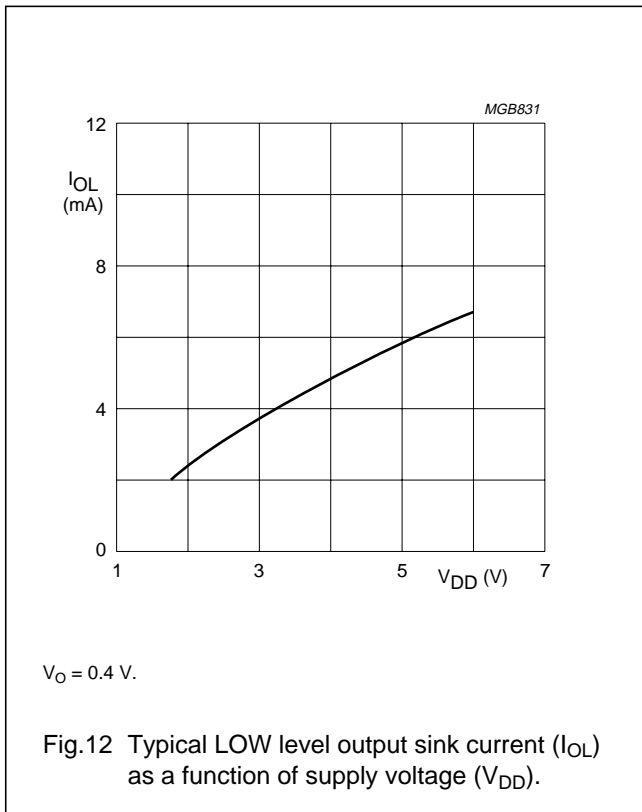
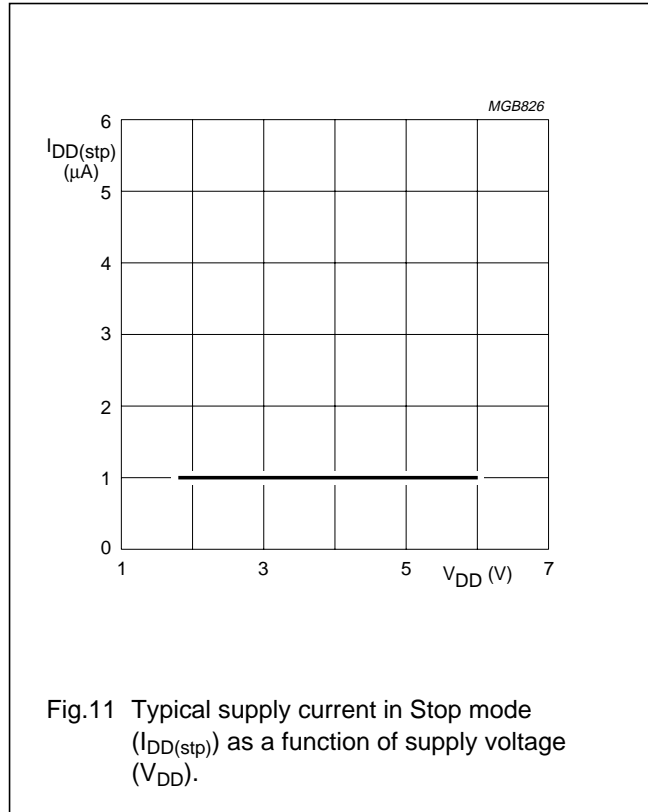
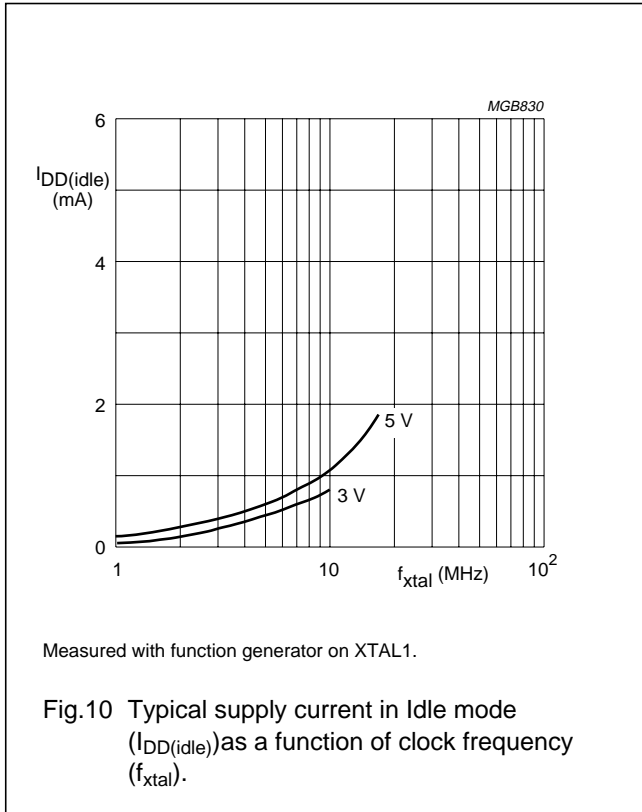

8-bit microcontrollers with DTMF generator and 128 bytes EEPROM

PCA3351C; 52C; 53C; PCD3351A; 52A; 53A

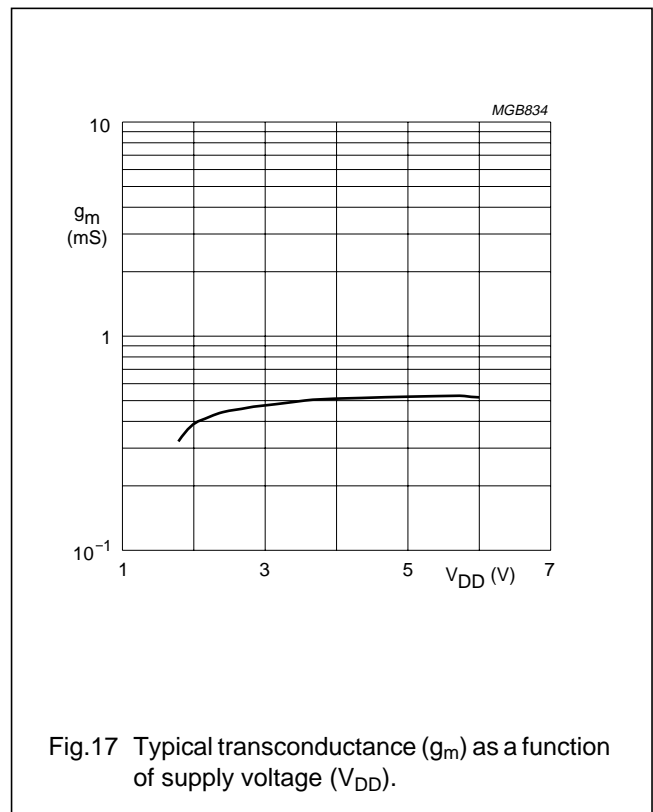
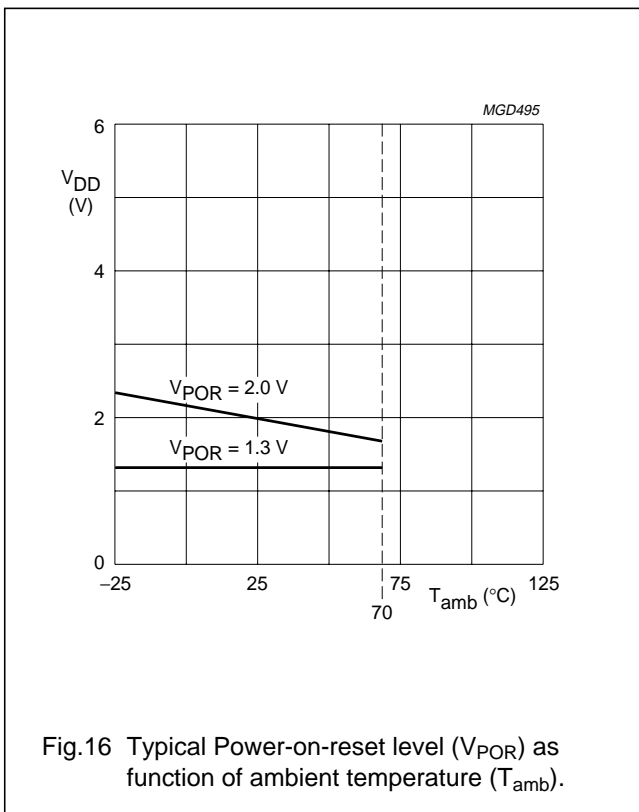
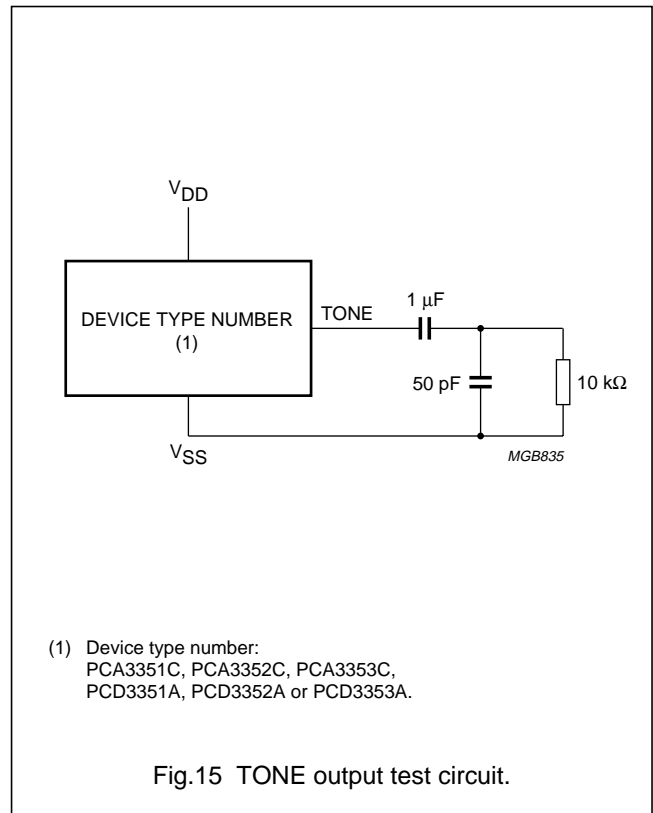
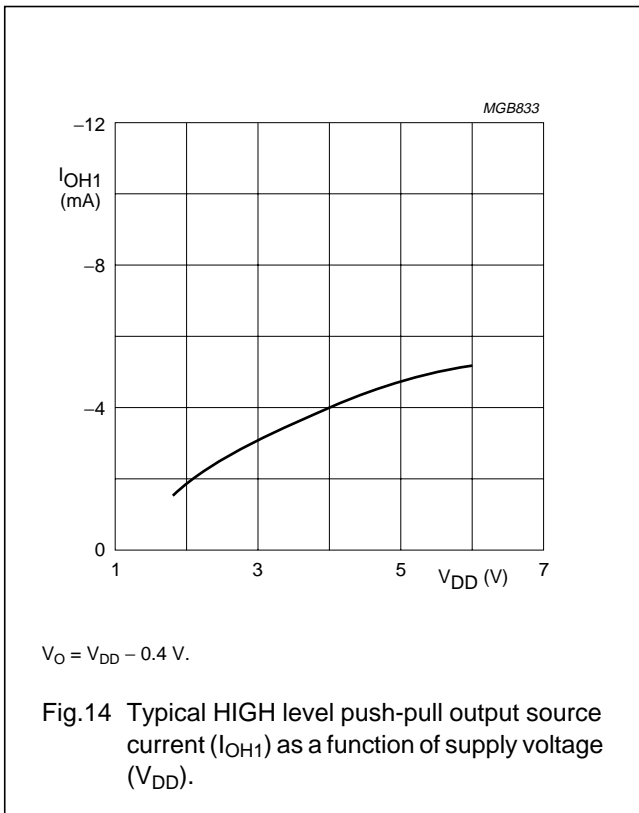

**8-bit microcontrollers with DTMF generator
and 128 bytes EEPROM**

**PCA3351C; 52C; 53C;
PCD3351A; 52A; 53A**

19 AC CHARACTERISTICS

$V_{DD} = 1.8$ to 6 V; $V_{SS} = 0$ V; $T_{amb} = 0$ to $+50$ °C (PCA335xC) or -25 to $+70$ °C (PCD335xA); all voltages with respect to V_{SS} ; unless otherwise specified.

SYMBOL	PARAMETER	CONDITIONS	MIN.	TYP.	MAX.	UNIT
t_r	rise time all outputs	$V_{DD} = 5$ V; $T_{amb} = 25$ °C; $C_L = 50$ pF	–	30	–	ns
t_f	fall time all outputs		–	30	–	ns
f_{xtal}	clock frequency	see Fig.6	1	–	16	MHz

8-bit microcontrollers with DTMF generator
and 128 bytes EEPROM

PCA3351C; 52C; 53C;
PCD3351A; 52A; 53A

20 PACKAGE OUTLINES

DIP28: plastic dual in-line package; 28 leads (600 mil)

SOT117-1

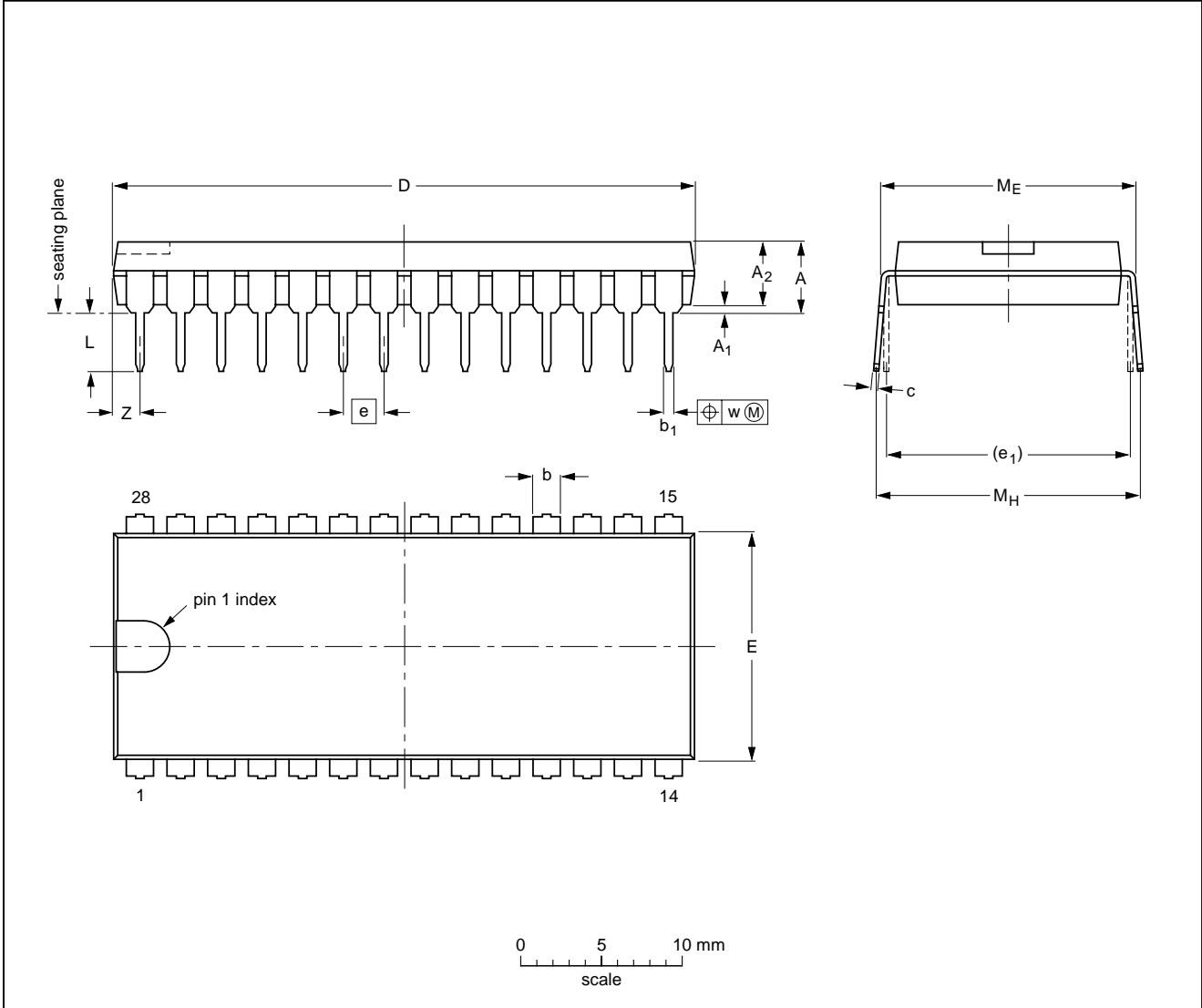

DIMENSIONS (inch dimensions are derived from the original mm dimensions)

UNIT	A max.	A ₁ min.	A ₂ max.	b	b ₁	c	D ⁽¹⁾	E ⁽¹⁾	e	e ₁	L	M _E	M _H	w	Z ⁽¹⁾ max.
mm	5.1	0.51	4.0	1.7 1.3	0.53 0.38	0.32 0.23	36.0 35.0	14.1 13.7	2.54	15.24	3.9 3.4	15.80 15.24	17.15 15.90	0.25	1.7
inches	0.20	0.020	0.16	0.066 0.051	0.020 0.014	0.013 0.009	1.41 1.34	0.56 0.54	0.10	0.60	0.15 0.13	0.62 0.60	0.68 0.63	0.01	0.067

Note

1. Plastic or metal protrusions of 0.25 mm maximum per side are not included.

OUTLINE VERSION	REFERENCES				EUROPEAN PROJECTION	ISSUE DATE
	IEC	JEDEC	EIAJ			
SOT117-1	051G05	MO-015AH				92-11-17 95-01-14

8-bit microcontrollers with DTMF generator
and 128 bytes EEPROM

PCA3351C; 52C; 53C;
PCD3351A; 52A; 53A

SO28: plastic small outline package; 28 leads; body width 7.5 mm

SOT136-1

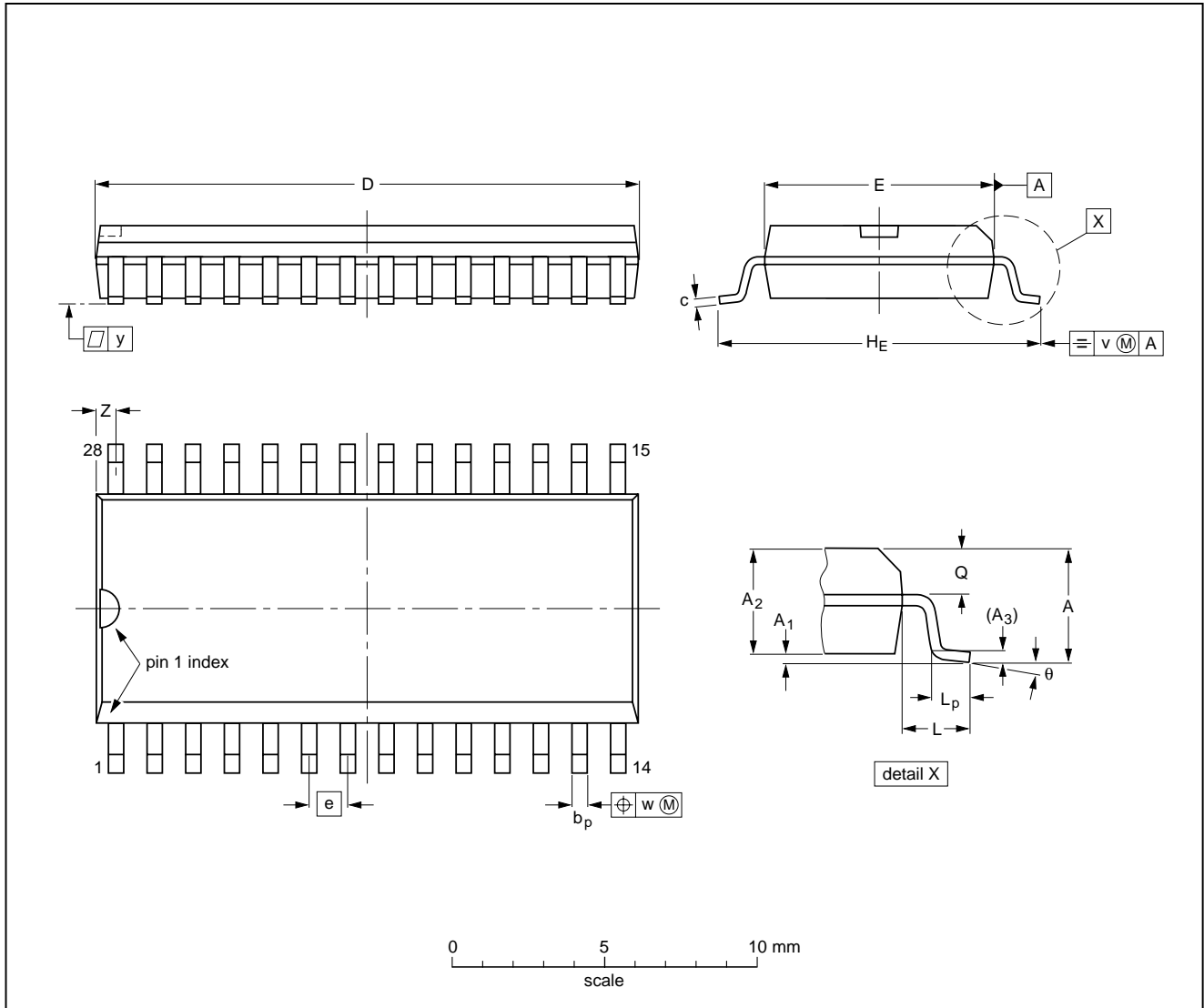

DIMENSIONS (inch dimensions are derived from the original mm dimensions)

UNIT	A max.	A ₁	A ₂	A ₃	b _p	c	D ⁽¹⁾	E ⁽¹⁾	e	H _E	L	L _p	Q	v	w	y	z ⁽¹⁾	θ
mm	2.65	0.30 0.10	2.45 2.25	0.25	0.49 0.36	0.32 0.23	18.1 17.7	7.6 7.4	1.27	10.65 10.00	1.4	1.1 0.4	1.1 1.0	0.25	0.25	0.1	0.9 0.4	8° 0°
inches	0.10	0.012 0.004	0.096 0.089	0.01	0.019 0.014	0.013 0.009	0.71 0.69	0.30 0.29	0.050	0.419 0.394	0.055	0.043 0.016	0.043 0.039	0.01	0.01	0.004	0.035 0.016	

Note

1. Plastic or metal protrusions of 0.15 mm maximum per side are not included.

OUTLINE VERSION	REFERENCES				EUROPEAN PROJECTION	ISSUE DATE
	IEC	JEDEC	EIAJ			
SOT136-1	075E06	MS-013AE				95-01-24 97-05-22

8-bit microcontrollers with DTMF generator
and 128 bytes EEPROM

PCA3351C; 52C; 53C;
PCD3351A; 52A; 53A

LQFP32: plastic low profile quad flat package; 32 leads; body 7 x 7 x 1.4 mm

SOT358-1

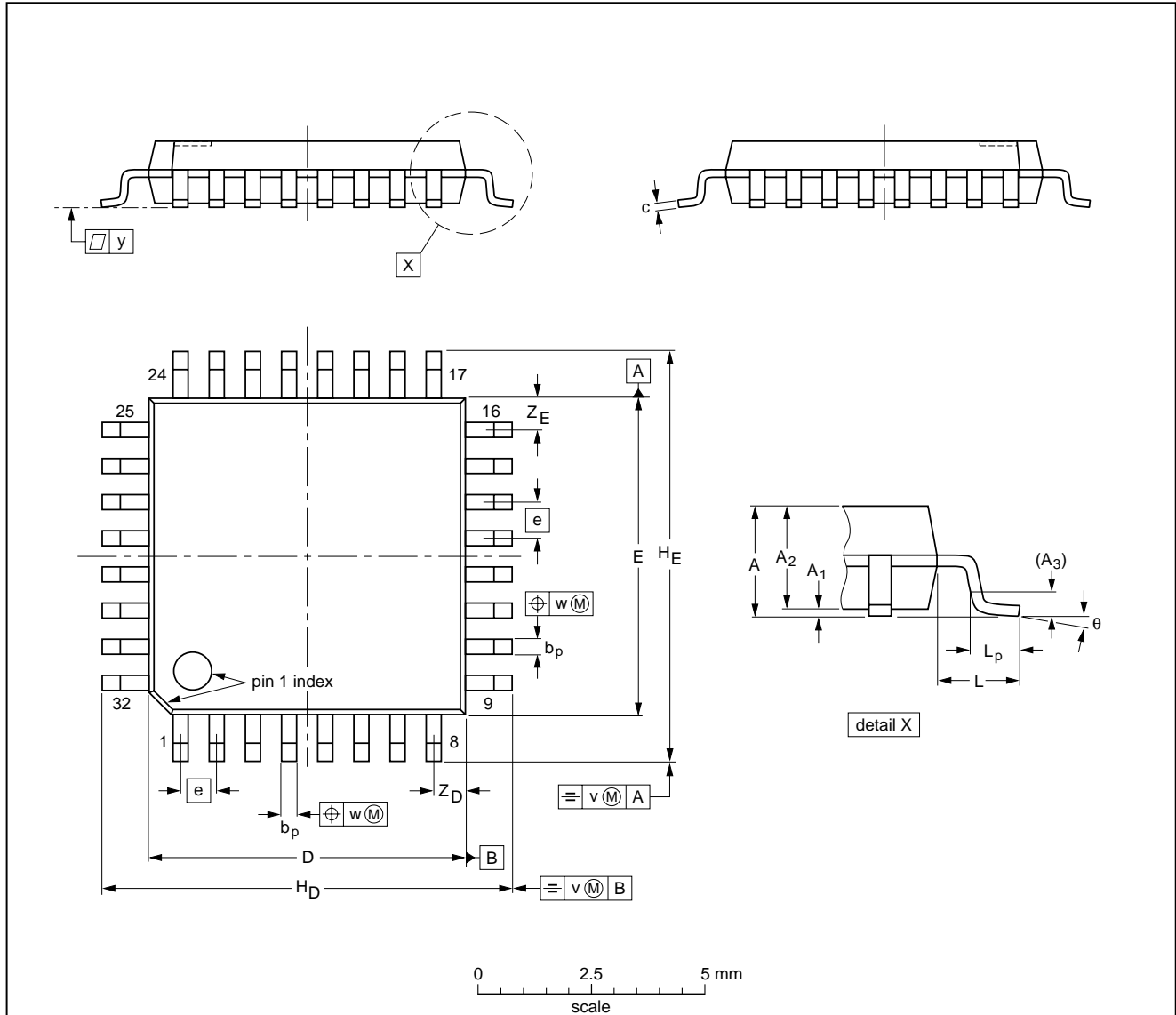

DIMENSIONS (mm are the original dimensions)

UNIT	A max.	A ₁	A ₂	A ₃	b _p	c	D ⁽¹⁾	E ⁽¹⁾	e	H _D	H _E	L	L _p	v	w	y	Z _D ⁽¹⁾	Z _E ⁽¹⁾	θ
mm	1.60	0.20 0.05	1.45 1.35	0.25	0.4 0.3	0.18 0.12	7.1 6.9	7.1 6.9	0.8	9.15 8.85	9.15 8.85	1.0	0.75 0.45	0.2	0.25	0.1	0.9 0.5	0.9 0.5	7° 0°

Note

1. Plastic or metal protrusions of 0.25 mm maximum per side are not included.

OUTLINE VERSION	REFERENCES				EUROPEAN PROJECTION	ISSUE DATE
	IEC	JEDEC	EIAJ			
SOT358 -1						95-12-19 97-08-04

8-bit microcontrollers with DTMF generator and 128 bytes EEPROM

PCA3351C; 52C; 53C;
PCD3351A; 52A; 53A

21 SOLDERING

21.1 Introduction

This text gives a very brief insight to a complex technology. A more in-depth account of soldering ICs can be found in our "Data Handbook IC26; Integrated Circuit Packages" (document order number 9398 652 90011).

There is no soldering method that is ideal for all IC packages. Wave soldering is often preferred when through-hole and surface mount components are mixed on one printed-circuit board. However, wave soldering is not always suitable for surface mount ICs, or for printed-circuit boards with high population densities. In these situations reflow soldering is often used.

21.2 Through-hole mount packages

21.2.1 SOLDERING BY DIPPING OR BY SOLDER WAVE

The maximum permissible temperature of the solder is 260 °C; solder at this temperature must not be in contact with the joints for more than 5 seconds. The total contact time of successive solder waves must not exceed 5 seconds.

The device may be mounted up to the seating plane, but the temperature of the plastic body must not exceed the specified maximum storage temperature ($T_{stg(max)}$). If the printed-circuit board has been pre-heated, forced cooling may be necessary immediately after soldering to keep the temperature within the permissible limit.

21.2.2 MANUAL SOLDERING

Apply the soldering iron (24 V or less) to the lead(s) of the package, either below the seating plane or not more than 2 mm above it. If the temperature of the soldering iron bit is less than 300 °C it may remain in contact for up to 10 seconds. If the bit temperature is between 300 and 400 °C, contact may be up to 5 seconds.

21.3 Surface mount packages

21.3.1 REFLOW SOLDERING

Reflow soldering requires solder paste (a suspension of fine solder particles, flux and binding agent) to be applied to the printed-circuit board by screen printing, stencilling or pressure-syringe dispensing before package placement.

Several methods exist for reflowing; for example, infrared/convection heating in a conveyor type oven. Throughput times (preheating, soldering and cooling) vary between 100 and 200 seconds depending on heating method.

Typical reflow peak temperatures range from 215 to 250 °C. The top-surface temperature of the packages should preferably be kept below 230 °C.

21.3.2 WAVE SOLDERING

Conventional single wave soldering is not recommended for surface mount devices (SMDs) or printed-circuit boards with a high component density, as solder bridging and non-wetting can present major problems.

To overcome these problems the double-wave soldering method was specifically developed.

If wave soldering is used the following conditions must be observed for optimal results:

- Use a double-wave soldering method comprising a turbulent wave with high upward pressure followed by a smooth laminar wave.
- For packages with leads on two sides and a pitch (e):
 - larger than or equal to 1.27 mm, the footprint longitudinal axis is **preferred** to be parallel to the transport direction of the printed-circuit board;
 - smaller than 1.27 mm, the footprint longitudinal axis **must** be parallel to the transport direction of the printed-circuit board.

The footprint must incorporate solder thieves at the downstream end.

- For packages with leads on four sides, the footprint must be placed at a 45° angle to the transport direction of the printed-circuit board. The footprint must incorporate solder thieves downstream and at the side corners.

During placement and before soldering, the package must be fixed with a droplet of adhesive. The adhesive can be applied by screen printing, pin transfer or syringe dispensing. The package can be soldered after the adhesive is cured.

Typical dwell time is 4 seconds at 250 °C.

A mildly-activated flux will eliminate the need for removal of corrosive residues in most applications.

21.3.3 MANUAL SOLDERING

Fix the component by first soldering two diagonally-opposite end leads. Use a low voltage (24 V or less) soldering iron applied to the flat part of the lead. Contact time must be limited to 10 seconds at up to 300 °C.

When using a dedicated tool, all other leads can be soldered in one operation within 2 to 5 seconds between 270 and 320 °C.

8-bit microcontrollers with DTMF generator and 128 bytes EEPROM

PCA3351C; 52C; 53C;
PCD3351A; 52A; 53A

21.4 Suitability of IC packages for wave, reflow and dipping soldering methods

MOUNTING	PACKAGE	SOLDERING METHOD		
		WAVE	REFLOW ⁽¹⁾	DIPPING
Through-hole mount	DBS, DIP, HDIP, SDIP, SIL	suitable ⁽²⁾	–	suitable
Surface mount	BGA, LFBGA, SQFP, TFBGA	not suitable	suitable	–
	HBCC, HLQFP, HSQFP, HSOP, HTQFP, HTSSOP, SMS	not suitable ⁽³⁾	suitable	–
	PLCC ⁽⁴⁾ , SO, SOJ	suitable	suitable	–
	LQFP, QFP, TQFP	not recommended ⁽⁴⁾⁽⁵⁾	suitable	–
	SSOP, TSSOP, VSO	not recommended ⁽⁶⁾	suitable	–

Notes

- All surface mount (SMD) packages are moisture sensitive. Depending upon the moisture content, the maximum temperature (with respect to time) and body size of the package, there is a risk that internal or external package cracks may occur due to vaporization of the moisture in them (the so called popcorn effect). For details, refer to the Drypack information in the “*Data Handbook IC26; Integrated Circuit Packages; Section: Packing Methods*”.
- For SDIP packages, the longitudinal axis must be parallel to the transport direction of the printed-circuit board.
- These packages are not suitable for wave soldering as a solder joint between the printed-circuit board and heatsink (at bottom version) can not be achieved, and as solder may stick to the heatsink (on top version).
- If wave soldering is considered, then the package must be placed at a 45° angle to the solder wave direction. The package footprint must incorporate solder thieves downstream and at the side corners.
- Wave soldering is only suitable for LQFP, QFP and TQFP packages with a pitch (e) equal to or larger than 0.8 mm; it is definitely not suitable for packages with a pitch (e) equal to or smaller than 0.65 mm.
- Wave soldering is only suitable for SSOP and TSSOP packages with a pitch (e) equal to or larger than 0.65 mm; it is definitely not suitable for packages with a pitch (e) equal to or smaller than 0.5 mm.

22 DEFINITIONS

Data sheet status	
Objective specification	This data sheet contains target or goal specifications for product development.
Preliminary specification	This data sheet contains preliminary data; supplementary data may be published later.
Product specification	This data sheet contains final product specifications.
Limiting values	
Limiting values given are in accordance with the Absolute Maximum Rating System (IEC 134). Stress above one or more of the limiting values may cause permanent damage to the device. These are stress ratings only and operation of the device at these or at any other conditions above those given in the Characteristics sections of the specification is not implied. Exposure to limiting values for extended periods may affect device reliability.	
Application information	
Where application information is given, it is advisory and does not form part of the specification.	

23 LIFE SUPPORT APPLICATIONS

These products are not designed for use in life support appliances, devices, or systems where malfunction of these products can reasonably be expected to result in personal injury. Philips customers using or selling these products for use in such applications do so at their own risk and agree to fully indemnify Philips for any damages resulting from such improper use or sale.

8-bit microcontrollers with DTMF generator
and 128 bytes EEPROM

PCA3351C; 52C; 53C;
PCD3351A; 52A; 53A

NOTES

8-bit microcontrollers with DTMF generator
and 128 bytes EEPROM

PCA3351C; 52C; 53C;
PCD3351A; 52A; 53A

NOTES

8-bit microcontrollers with DTMF generator
and 128 bytes EEPROM

PCA3351C; 52C; 53C;
PCD3351A; 52A; 53A

NOTES

Philips Semiconductors – a worldwide company

Argentina: see South America

Australia: 3 Figtree Drive, HOMEBUSH, NSW 2140,
Tel. +61 2 9704 8141, Fax. +61 2 9704 8139

Austria: Computerstr. 6, A-1101 WIEN, P.O. Box 213,
Tel. +43 1 60 101 1248, Fax. +43 1 60 101 1210

Belarus: Hotel Minsk Business Center, Bld. 3, r. 1211, Volodarski Str. 6,
220050 MINSK, Tel. +375 172 20 0733, Fax. +375 172 20 0773

Belgium: see The Netherlands

Brazil: see South America

Bulgaria: Philips Bulgaria Ltd., Energoproject, 15th floor,
51 James Bourchier Blvd., 1407 SOFIA,
Tel. +359 2 68 9211, Fax. +359 2 68 9102

Canada: PHILIPS SEMICONDUCTORS/COMPONENTS,
Tel. +1 800 234 7381, Fax. +1 800 943 0087

China/Hong Kong: 501 Hong Kong Industrial Technology Centre,
72 Tat Chee Avenue, Kowloon Tong, HONG KONG,
Tel. +852 2319 7888, Fax. +852 2319 7700

Colombia: see South America

Czech Republic: see Austria

Denmark: Sydhavnsgade 23, 1780 COPENHAGEN V,
Tel. +45 33 29 3333, Fax. +45 33 29 3905

Finland: Sinikalliontie 3, FIN-02630 ESPOO,
Tel. +358 9 615 800, Fax. +358 9 6158 0920

France: 51 Rue Carnot, BP317, 92156 SURESNES Cedex,
Tel. +33 1 4099 6161, Fax. +33 1 4099 6427

Germany: Hammerbrookstraße 69, D-20097 HAMBURG,
Tel. +49 40 2353 60, Fax. +49 40 2353 6300

Hungary: see Austria

India: Philips INDIA Ltd, Band Box Building, 2nd floor,
254-D, Dr. Annie Besant Road, Worli, MUMBAI 400 025,
Tel. +91 22 493 8541, Fax. +91 22 493 0966

Indonesia: PT Philips Development Corporation, Semiconductors Division,
Gedung Philips, Jl. Buncit Raya Kav.99-100, JAKARTA 12510,
Tel. +62 21 794 0040 ext. 2501, Fax. +62 21 794 0080

Ireland: Newstead, Clonskeagh, DUBLIN 14,
Tel. +353 1 7640 000, Fax. +353 1 7640 200

Israel: RAPAC Electronics, 7 Kehilat Saloniki St, PO Box 18053,
TEL AVIV 61180, Tel. +972 3 645 0444, Fax. +972 3 649 1007

Italy: PHILIPS SEMICONDUCTORS, Via Casati, 23 - 20052 MONZA (MI),
Tel. +39 039 203 6838, Fax +39 039 203 6800

Japan: Philips Bldg 13-37, Kohnan 2-chome, Minato-ku,
TOKYO 108-8507, Tel. +81 3 3740 5130, Fax. +81 3 3740 5057

Korea: Philips House, 260-199 Itaewon-dong, Yongsan-ku, SEOUL,
Tel. +82 2 709 1412, Fax. +82 2 709 1415

Malaysia: No. 76 Jalan Universiti, 46200 PETALING JAYA, SELANGOR,
Tel. +60 3 750 5214, Fax. +60 3 757 4880

Mexico: 5900 Gateway East, Suite 200, EL PASO, TEXAS 79905,
Tel. +9-5 800 234 7381, Fax +9-5 800 943 0087

Middle East: see Italy

Netherlands: Postbus 90050, 5600 PB EINDHOVEN, Bldg. VB,
Tel. +31 40 27 82785, Fax. +31 40 27 88399

New Zealand: 2 Wagener Place, C.P.O. Box 1041, AUCKLAND,
Tel. +64 9 849 4160, Fax. +64 9 849 7811

Norway: Box 1, Manglerud 0612, OSLO,
Tel. +47 22 74 8000, Fax. +47 22 74 8341

Pakistan: see Singapore

Philippines: Philips Semiconductors Philippines Inc.,
106 Valero St. Salcedo Village, P.O. Box 2108 MCC, MAKATI,
Metro MANILA, Tel. +63 2 816 6380, Fax. +63 2 817 3474

Poland: Al.Jerozolimskie 195 B, 02-222 WARSAW,
Tel. +48 22 5710 000, Fax. +48 22 5710 001

Portugal: see Spain

Romania: see Italy

Russia: Philips Russia, Ul. Usatcheva 35A, 119048 MOSCOW,
Tel. +7 095 755 6918, Fax. +7 095 755 6919

Singapore: Lorong 1, Toa Payoh, SINGAPORE 319762,
Tel. +65 350 2538, Fax. +65 251 6500

Slovakia: see Austria

Slovenia: see Italy

South Africa: S.A. PHILIPS Pty Ltd., 195-215 Main Road Martindale,
2092 JOHANNESBURG, P.O. Box 58088 Newville 2114,
Tel. +27 11 471 5401, Fax. +27 11 471 5398

South America: Al. Vicente Pinzon, 173, 6th floor,
04547-130 SÃO PAULO, SP, Brazil,
Tel. +55 11 821 2333, Fax. +55 11 821 2382

Spain: Balmes 22, 08007 BARCELONA,
Tel. +34 93 301 6312, Fax. +34 93 301 4107

Sweden: Kottbygatan 7, Akalla, S-16485 STOCKHOLM,
Tel. +46 8 5985 2000, Fax. +46 8 5985 2745

Switzerland: Allmendstrasse 140, CH-8027 ZÜRICH,
Tel. +41 1 488 2741 Fax. +41 1 488 3263

Taiwan: Philips Semiconductors, 6F, No. 96, Chien Kuo N. Rd., Sec. 1,
TAIPEI, Taiwan Tel. +886 2 2134 2886, Fax. +886 2 2134 2874

Thailand: PHILIPS ELECTRONICS (THAILAND) Ltd.,
209/2 Sanpavuth-Bangna Road Prakanong, BANGKOK 10260,
Tel. +66 2 745 4090, Fax. +66 2 398 0793

Turkey: Yukari Dudullu, Org. San. Blg., 2.Cad. Nr. 28 81260 Umraniye,
ISTANBUL, Tel. +90 216 522 1500, Fax. +90 216 522 1813

Ukraine: PHILIPS UKRAINE, 4 Patrice Lumumba str., Building B, Floor 7,
252042 KIEV, Tel. +380 44 264 2776, Fax. +380 44 268 0461

United Kingdom: Philips Semiconductors Ltd., 276 Bath Road, Hayes,
MIDDLESEX UB3 5BX, Tel. +44 208 730 5000, Fax. +44 208 754 8421

United States: 811 East Arques Avenue, SUNNYVALE, CA 94088-3409,
Tel. +1 800 234 7381, Fax. +1 800 943 0087

Uruguay: see South America

Vietnam: see Singapore

Yugoslavia: PHILIPS, Trg N. Pasica 5/v, 11000 BEOGRAD,
Tel. +381 11 62 5344, Fax.+381 11 63 5777

For all other countries apply to: Philips Semiconductors,
International Marketing & Sales Communications, Building BE-p, P.O. Box 218,
5600 MD EINDHOVEN, The Netherlands, Fax. +31 40 27 24825

Internet: <http://www.semiconductors.philips.com>

© Philips Electronics N.V. 1999

SCA 68

All rights are reserved. Reproduction in whole or in part is prohibited without the prior written consent of the copyright owner.

The information presented in this document does not form part of any quotation or contract, is believed to be accurate and reliable and may be changed without notice. No liability will be accepted by the publisher for any consequence of its use. Publication thereof does not convey nor imply any license under patent- or other industrial or intellectual property rights.

Printed in The Netherlands

465002/07/pp36

Date of release: 1999 Oct 28

Document order number: 9397 750 06528

Let's make things better.

**Philips
Semiconductors**



PHILIPS