

# DATA SHEET



## **PCF2105** LCD controller/driver

Product specification  
Supersedes data of 1997 Dec 08  
File under Integrated Circuits, IC12

1998 Jul 30

**LCD controller/driver****PCF2105**

<b>CONTENTS</b>		
1	FEATURES	
2	APPLICATIONS	
3	GENERAL DESCRIPTION	
3.1	Packages	
3.2	Available types	
4	ORDERING INFORMATION	
5	BLOCK DIAGRAM	
6	PINNING	
7	PAD FUNCTIONS	
7.1	RS: Register Select (parallel control)	9.4
7.2	R/W: read/write (parallel control)	9.4.1
7.3	E: data bus clock (parallel control)	9.4.2
7.4	DB7 to DB0: data bus (parallel control)	9.4.3
7.5	C60 to C1: column driver outputs	9.5
7.6	R32 to R1: row driver outputs	9.6
7.7	V <sub>LCD</sub> : LCD power supply	9.6.1
7.8	OSC: oscillator	9.6.2
7.9	SCL: serial clock line	9.7
7.10	SDA: serial data line	9.8
7.11	SA0: address input	9.9
7.12	T1: test input	9.10
8	FUNCTIONAL DESCRIPTION	9.11
8.1	LCD bias voltage generator	10
8.2	Oscillator	
8.3	External clock	
8.4	Power-on reset	
8.5	Registers	
8.6	Busy flag	
8.7	Address Counter (AC)	
8.8	Display Data RAM (DDRAM)	
8.9	Character Generator ROM (CGROM)	
8.10	Character Generator RAM (CGRAM)	
8.11	Cursor control circuit	
8.12	Timing generator	
8.13	LCD row and column drivers	
8.14	Programming of the MUX rate 1 : 16	
8.15	Programming of the MUX rate 1 : 32	
8.16	Reset function	
9	INSTRUCTIONS	
9.1	Clear display	
9.2	Return home	
9.3	Entry mode set	
9.3.1	I/D	
9.3.2	S	
		Display control
		D
		C
		B
		Cursor/display shift
		Function set
		DL (parallel mode only)
		N and M
		Set CGRAM address
		Set DDRAM address
		Read busy flag and address
		Write data to CGRAM or DDRAM
		Read data from CGRAM or DDRAM
		10
		INTERFACE TO MICROCONTROLLER (PARALLEL INTERFACE)
		11
		INTERFACE TO MICROCONTROLLER (I <sup>2</sup> C-BUS INTERFACE)
		11.1
		Characteristics of the I <sup>2</sup> C-bus
		11.2
		Bit transfer
		11.3
		START and STOP conditions
		11.4
		System configuration
		11.5
		Acknowledge
		11.6
		I <sup>2</sup> C-bus protocol
		12
		LIMITING VALUES
		13
		HANDLING
		14
		DC CHARACTERISTICS
		15
		AC CHARACTERISTICS
		16
		TIMING DIAGRAMS
		17
		APPLICATION INFORMATION
		17.1
		4-bit operation, 2 × 12 display using internal reset
		17.2
		8-bit operation, 2 × 12 display using internal reset
		17.3
		8-bit operation, 2 × 24 display
		17.4
		I <sup>2</sup> C-bus operation, 2 × 12 display
		17.5
		Initializing by instruction
		18
		BONDING PAD LOCATIONS
		19
		DEFINITIONS
		20
		LIFE SUPPORT APPLICATIONS
		21
		PURCHASE OF PHILIPS I <sup>2</sup> C COMPONENTS

## LCD controller/driver

## PCF2105

**1 FEATURES**

- Single chip Liquid Crystal Display (LCD) controller/driver
- 1 or 2-line display of up to 24 characters per line, or 2 or 4-line display of up to 12 characters per line
- 5 × 7 character format plus cursor; 5 × 8 for kana (Japanese syllabary) and user-defined symbols
- On-chip generation of intermediate LCD bias voltages
- On-chip oscillator requires no external components (external clock also possible)
- Display data RAM: 80 characters
- Character generator ROM: 240 characters
- Character generator RAM: 16 characters
- 4 or 8-bit parallel bus or 2-wire I<sup>2</sup>C-bus interface (400 kHz)
- CMOS and TTL compatible
- 32 row, 60 column outputs
- Multiplex (MUX) rates 1 : 32 and 1 : 16
- Uses common 11-code instruction set
- Logic supply voltage range:  $V_{DD} - V_{SS} = 2.5$  to 6 V
- Display supply voltage range:  $V_{DD} - V_{LCD} = 3.5$  to 9 V
- Low power consumption
- I<sup>2</sup>C-bus address selection (SA0): 011101.

**2 APPLICATIONS**

- Telecom equipment
- Portable instruments
- Point-of-sale terminals.

**3 GENERAL DESCRIPTION**

The PCF2105 integrated circuit is similar to the PCF2114x (described in the "PCF2116 family" data sheet) but does not contain the high voltage generator of that device.

**4 ORDERING INFORMATION**

TYPE NUMBER	PACKAGE		
	NAME	DESCRIPTION	VERSION
PCF2105MU/2	–	chip with bumps in tray	–



Furthermore, a fast I<sup>2</sup>C-bus interface (400 kHz) is provided.

The PCF2105 is optimized for chip-on-glass applications.

A specific letter code 'M' for a character set is programmed in the Character Generator ROM (CGROM) (see Fig.5).

The PCF2105 is a low power CMOS LCD controller/driver, designed to drive a split screen dot matrix LCD of 1 or 2 lines by 24 characters or 2 or 4 lines by 12 characters with a 5 × 8 dot format. All necessary functions for the display are provided in a single chip, including on-chip generation of LCD bias voltages which results in a minimum of external components and lower system power consumption. To allow partial  $V_{DD}$  shutdown the ESD protection system of the SCL and SDA pads does not use a diode connected to  $V_{DD}$ .

The chip contains a character generator and displays alphanumeric and kana characters. The PCF2105 interfaces to most microcontrollers via a 4 or 8-bit parallel bus, or via the 2-wire I<sup>2</sup>C-bus.

**3.1 Packages**

- PCF2105MU/2: chip with bumps in tray.

**3.2 Available types**

- PCF2105MU/2: character set 'M' in CGROM.

LCD controller/driver

PCF2105

5 BLOCK DIAGRAM

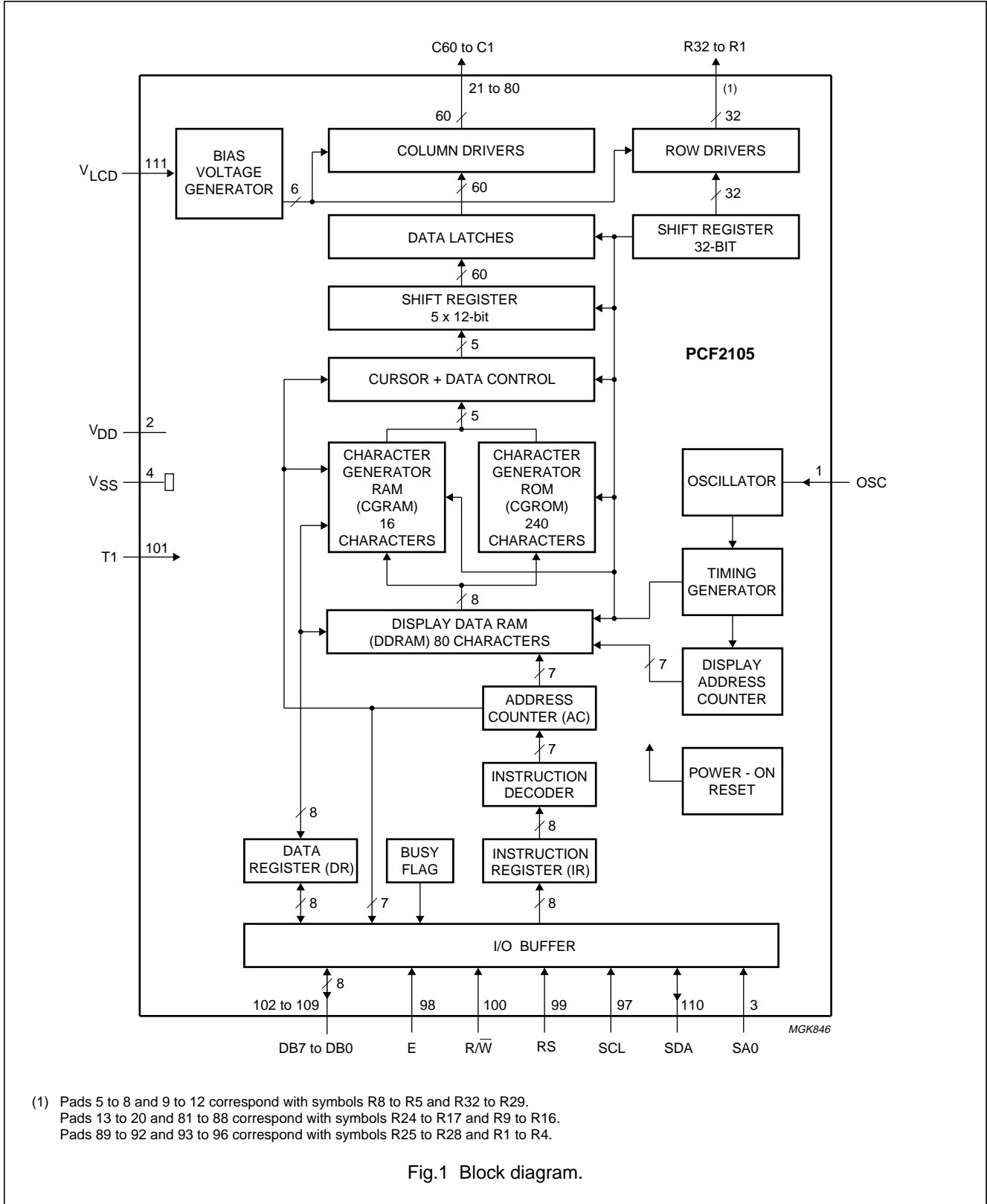

## LCD controller/driver

## PCF2105

## 6 PINNING

SYMBOL	PAD	I/O	DESCRIPTION
OSC	1	I	oscillator/external clock input
V <sub>DD</sub>	2	–	logic supply voltage
SA0	3	I	I <sup>2</sup> C-bus address selection input
V <sub>SS</sub>	4	–	logic ground
R8 to R5	5 to 8	O	LCD row driver outputs
R32 to R29	9 to 12	O	LCD row driver outputs
R24 to R17	13 to 20	O	LCD row driver outputs
C60 to C1	21 to 80	O	LCD column driver outputs
R9 to R16	81 to 88	O	LCD row driver outputs
R25 to R28	89 to 92	O	LCD row driver outputs
R1 to R4	93 to 96	O	LCD row driver outputs
SCL	97	I	I <sup>2</sup> C-bus serial clock input
E	98	I	data bus clock input
RS	99	I	register select input
R/ $\overline{W}$	100	I	read/write input
T1	101	I	test input
DB7 to DB0	102 to 109	I/O	8-bit bidirectional data bus input/output
SDA	110	I/O	I <sup>2</sup> C-bus serial data input/output
V <sub>LCD</sub>	111	I	LCD supply voltage input

## 7 PAD FUNCTIONS

## 7.1 RS: Register Select (parallel control)

Bit RS selects the register to be accessed for read and write when the device is controlled by the parallel interface. RS = 0 selects the instruction register for write and the busy flag and address counter for read. RS = 1 selects the data register for both read and write. There is an internal pull-up resistor on pad RS.

7.2 R/ $\overline{W}$ : read/write (parallel control)

R/ $\overline{W}$  selects either the read (R/ $\overline{W}$  = 1) or write (R/ $\overline{W}$  = 0) operation when control is by the parallel interface. There is an internal pull-up resistor on pad R/ $\overline{W}$ .

## 7.3 E: data bus clock (parallel control)

Pad E should be HIGH to signal the start of a read or write operation when the device is controlled by the parallel interface. Data is clocked in or out of the chip on the falling edge of the clock. Note that pad E must be connected to V<sub>SS</sub> (logic 0) when I<sup>2</sup>C-bus control is used.

## 7.4 DB7 to DB0: data bus (parallel control)

The bidirectional, 3-state data bus transfers data between the system controller and the PCF2105. DB7 acts as the busy flag, signalling that internal operations are not yet completed. In 4-bit operations, DB7 to DB4 are used and DB3 to DB0 must be left open-circuit. There is an internal pull-up resistor on each of the data lines. Note that pads DB7 to DB0 must be left open-circuit when I<sup>2</sup>C-bus control is used.

## 7.5 C60 to C1: column driver outputs

Pads C60 to C1 output the data for pairs of columns. This arrangement permits optimized Chip-On-Glass (COG) layout for 4-line by 12 characters.

## 7.6 R32 to R1: row driver outputs

Pads R32 to R1 output the row select waveforms to the left and right halves of the display.

7.7 V<sub>LCD</sub>: LCD power supply

Negative power supply for the liquid crystal display.

LCD controller/driver

PCF2105

**7.8 OSC: oscillator**

When the on-chip oscillator is used, pad OSC must be connected to  $V_{DD}$ . An external clock signal, if used, is input at pad OSC.

**7.9 SCL: serial clock line**

Pad SCL is input for the I<sup>2</sup>C-bus clock signal.

**7.10 SDA: serial data line**

Pad SDA is input/output for the I<sup>2</sup>C-bus data line.

**7.11 SA0: address input**

The hardware subaddress line is used to program the device subaddress for 2 different PCF2105s on the same I<sup>2</sup>C-bus.

**7.12 T1: test input**

Pad T1 must be connected to  $V_{SS}$ . Not user accessible.

**8 FUNCTIONAL DESCRIPTION**

Figure 1 shows the block diagram for the PCF2105. Details are explained in subsequent sections.

**8.1 LCD bias voltage generator**

The intermediate bias voltages for the LCD are generated on-chip. This removes the need for an external resistive bias chain and significantly reduces the system power consumption. The optimum levels depend on the multiplex (MUX) rate and are selected automatically when the number of lines in the display is defined.

The optimum value of the LCD operating voltage  $V_{OP}$  depends on the MUX rate, the LCD threshold voltage  $V_{th}$  and the number of bias levels. The relationships, together with the discrimination ratio (D) are given in Table 1.

Using a 5-level bias scheme for MUX rate 1 : 16 allows  $V_{OP} < 5$  V for most LCDs. The effect on the display contrast is negligible.

**Table 1** Optimum values for  $V_{OP}$

MUX RATE	NUMBER OF BIAS LEVELS	$\frac{V_{OP}}{V_{th}}$	$D = \frac{V_{on}}{V_{off}}$
1 : 16	5	3.67	1.277
1 : 32	6	5.19	1.196

**8.2 Oscillator**

The on-chip oscillator provides the clock signal for the display system. No external components are required. Pad OSC must be connected to  $V_{DD}$ .

**8.3 External clock**

If an external clock is to be used, it must be input at pad OSC. The resulting display frame frequency is given

$$\text{by } f_{\text{frame}} = \frac{f_{\text{osc}}}{2304}$$

A clock signal must always be present, otherwise the LCD may be frozen in a DC state.

**8.4 Power-on reset**

The Power-on reset block initializes the chip after power-on or power failure.

**8.5 Registers**

The PCF2105 has two 8-bit registers, an Instruction Register (IR) and a Data Register (DR). The Register Select (RS) signal determines which register will be accessed.

The IR stores instruction codes such as 'clear display' and 'cursor shift', and address information for the DDRAM and CGRAM. The system controller can write data to but can not read data from the instruction register.

The DR temporarily stores data to be read from the DDRAM and CGRAM. When reading, data from the DDRAM or CGRAM (corresponding to the address in the address counter) is written to the DR prior to being read by the 'read data' instruction.

**8.6 Busy flag**

The Busy Flag (BF) indicates the free or busy status of the PCF2105. Bit BF = 1 indicates that the chip is busy and further instructions will not be accepted. The BF is output at pad DB7 when bit RS = 0 and bit  $R/\bar{W}$  = 1. Instructions should only be written after checking that BF = 0 or waiting for the required number of clock cycles.

**8.7 Address Counter (AC)**

The AC assigns addresses to the DDRAM and CGRAM for reading and writing and is set by the instructions 'set CGRAM address' and 'set DDRAM address'. After a read/write operation the AC is automatically incremented or decremented by 1. The AC contents are output to the bus (pads DB6 to DB0) when bit RS = 0 and bit  $R/\bar{W}$  = 1.

---

## LCD controller/driver

## PCF2105

---

### 8.8 Display Data RAM (DDRAM)

The DDRAM stores up to 80 characters of display data, represented by 8-bit character codes. DDRAM locations not used for storing display data can be used as general purpose RAM. The basic DDRAM-to-display mapping scheme is shown in Fig.2. With no display shift, the characters represented by the codes in the first 12 or 24 DDRAM locations, starting at address 00 in line 1, are displayed. Subsequent lines display data starting at addresses 20, 40, or 60 hexadecimal (hex). Figures 3 and 4 show the DDRAM-to-display mapping scheme when the display is shifted.

The address range for a 1-line display is 00 to 4F; for a 2-line display from 00 to 27 (line 1) and 40 to 67 (line 2); for a 4-line display from 00 to 13, 20 to 33, 40 to 53 and 60 to 73 for lines 1, 2, 3 and 4 respectively. For 2 and 4-line displays the end address of one line and the start address of the next line are not successive. When the display is shifted each line wraps around independently of the others (see Figs 3 and 4).

When data is written to the DDRAM, wrap-around occurs from 4F to 00 in 1-line display and from 27 to 40 and 67 to 00 in 2-line display; from 13 to 20, 33 to 40, 53 to 60 and 73 to 00 in 4-line display.

### 8.9 Character Generator ROM (CGROM)

The CGROM generates 240 character patterns in  $5 \times 8$  dot format from 8-bit character codes. Figure 5 shows the character set currently available.

### 8.10 Character Generator RAM (CGRAM)

Up to 16 user-defined characters may be stored in the CGRAM. The CGROM and CGRAM use a common address space, of which the first column is reserved for the CGRAM (see Fig.5). Figure 6 shows the addressing principle for the CGRAM.

### 8.11 Cursor control circuit

The cursor control circuit generates the cursor (underline and/or character blink as shown in Fig.7) at the DDRAM address contained in the address counter. When the address counter contains the CGRAM address the cursor will be inhibited.

### 8.12 Timing generator

The timing generator produces the various signals required to drive the internal circuitry. Internal chip operation is not disturbed by operations on the data buses.

### 8.13 LCD row and column drivers

The PCF2105 contains 32 row drivers and 60 column drivers. They connect the appropriate LCD bias voltages in sequence to the display, in accordance with the data to be displayed. The bias voltages and the timing are selected automatically when the number of lines in the display is selected. Figures 8 and 9 show typical waveforms.

In the 1-line display (MUX rate 1 : 16), the row outputs are driven in pairs, for example R1/R17 and R2/R18. This allows the output pairs to be connected in parallel, thereby providing greater drive capability.

Unused outputs should be left unconnected.

LCD controller/driver

PCF2105

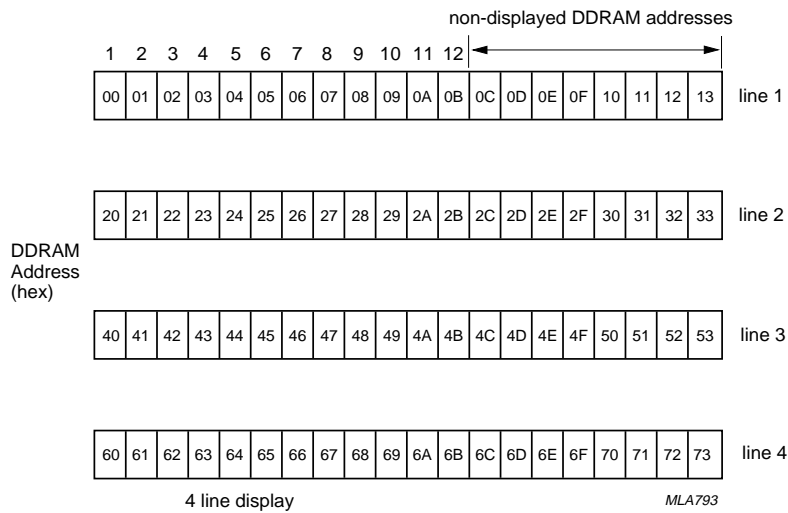
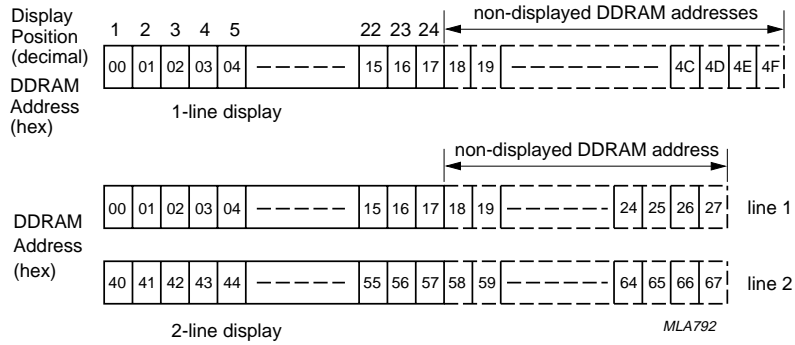

Fig.2 DDRAM-to-display mapping; no shift.



LCD controller/driver

PCF2105

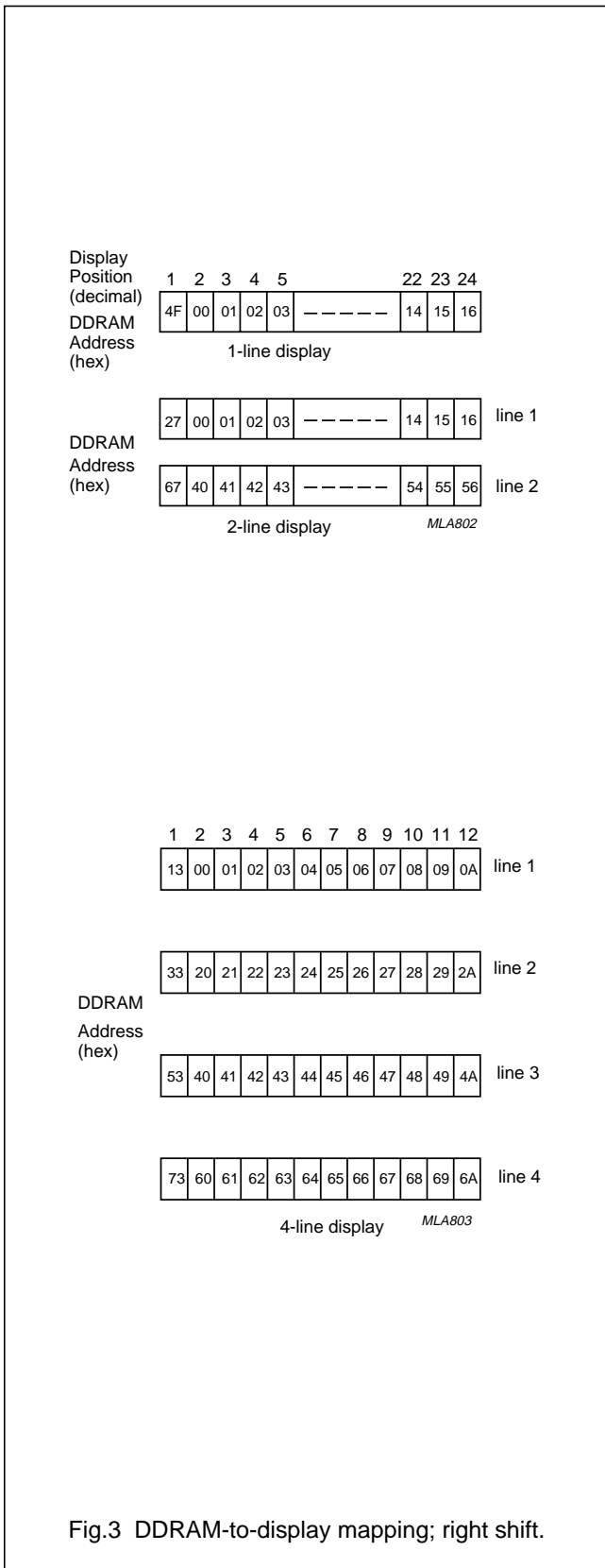

Fig.3 DDRAM-to-display mapping; right shift.

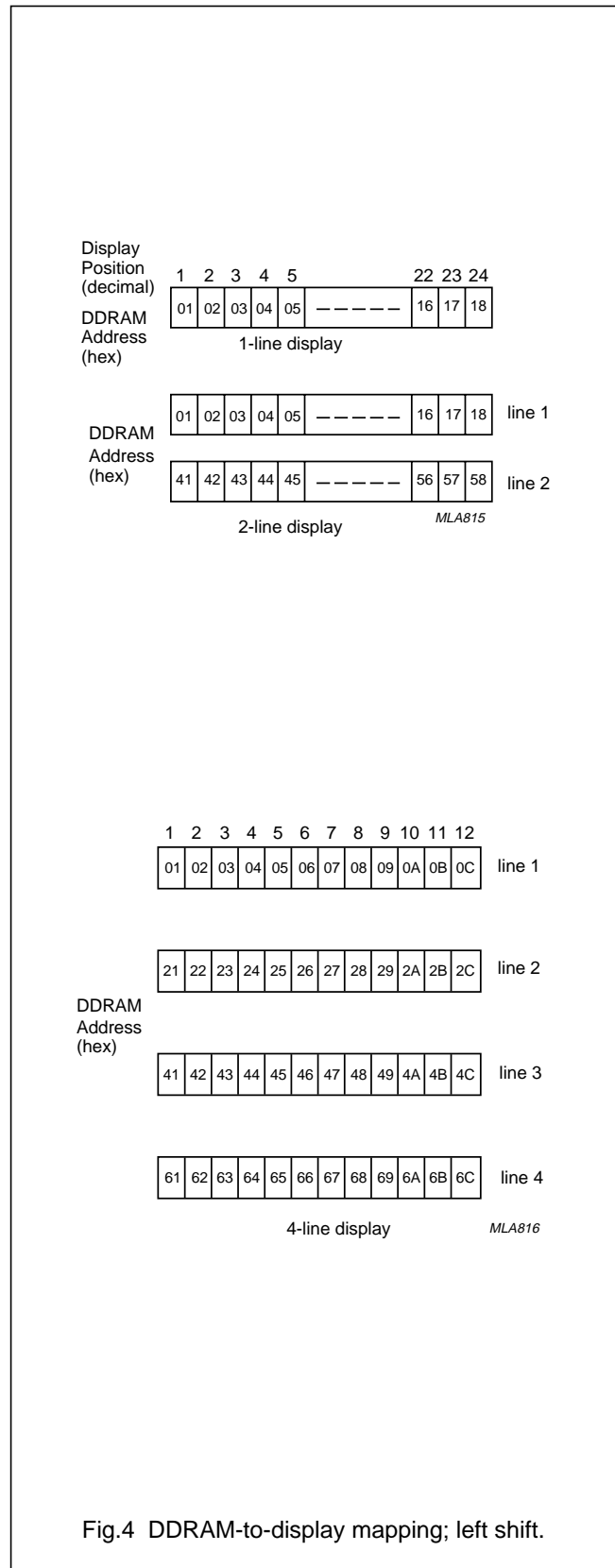

Fig.4 DDRAM-to-display mapping; left shift.

LCD controller/driver

PCF2105

upper 4 bits lower 4 bits	0000	0001	0010	0011	0100	0101	0110	0111	1000	1001	1010	1011	1100	1101	1110	1111
xxxx 0000	CG RAM 1															
xxxx 0001	2															
xxxx 0010	3															
xxxx 0011	4															
xxxx 0100	5															
xxxx 0101	6															
xxxx 0110	7															
xxxx 0111	8															
xxxx 1000	9															
xxxx 1001	10															
xxxx 1010	11															
xxxx 1011	12															
xxxx 1100	13															
xxxx 1101	14															
xxxx 1110	15															
xxxx 1111	16															

MGK847

Fig.5 Character set 'M' in CGROM.

LCD controller/driver

PCF2105

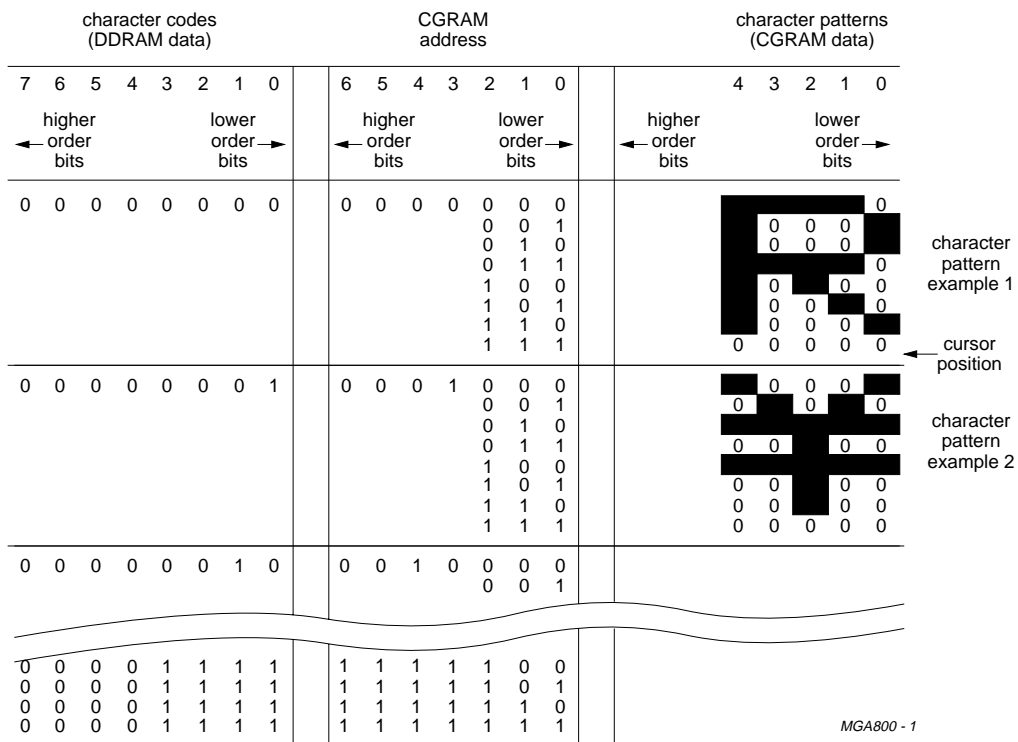

MGA800 - 1

Character code bits 0 to 3 correspond to CGRAM address bits 3 to 6.

CGRAM address bits 0 to 2 designate character pattern line position. The 8th line is the cursor position and display is performed by logical OR with the cursor. Data in the 8th line will appear in the cursor position.

Character pattern column positions correspond to CGRAM data bits 0 to 4; bit 4 being at the left end, as shown in this figure.

CGRAM character patterns are selected when character code bits 4 to 7 are all logic 0. CGRAM data is logic 1 corresponds to selection for display.

Only bits 0 to 5 of the CGRAM address are set by the 'set CGRAM address' instruction. Bit 6 can be set using the 'set DDRAM address' instruction or by using the auto-increment feature during CGRAM write. All bits 0 to 6 can be read using the 'read busy flag and address' instruction.

Fig.6 Relationship between CGRAM addresses, data and display patterns.

LCD controller/driver

PCF2105

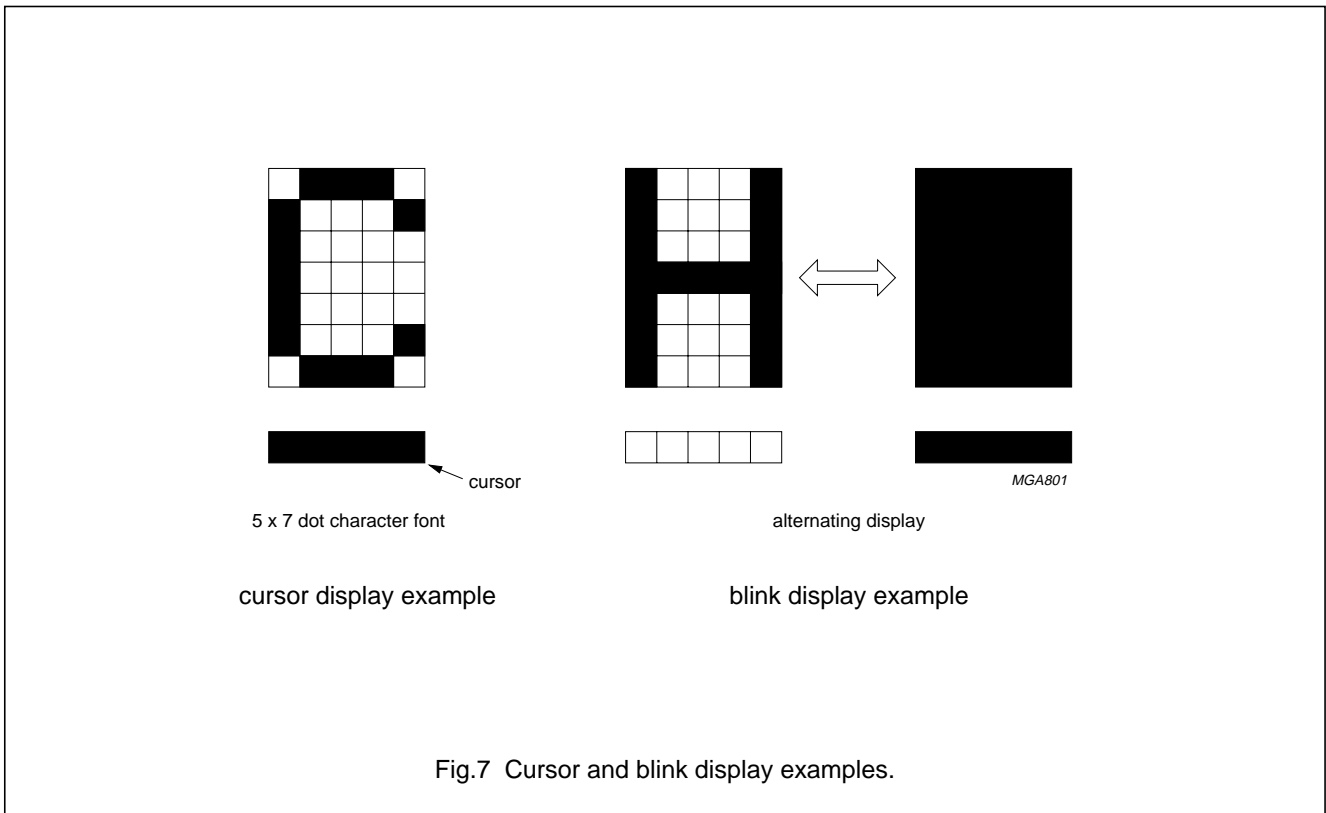

LCD controller/driver

PCF2105

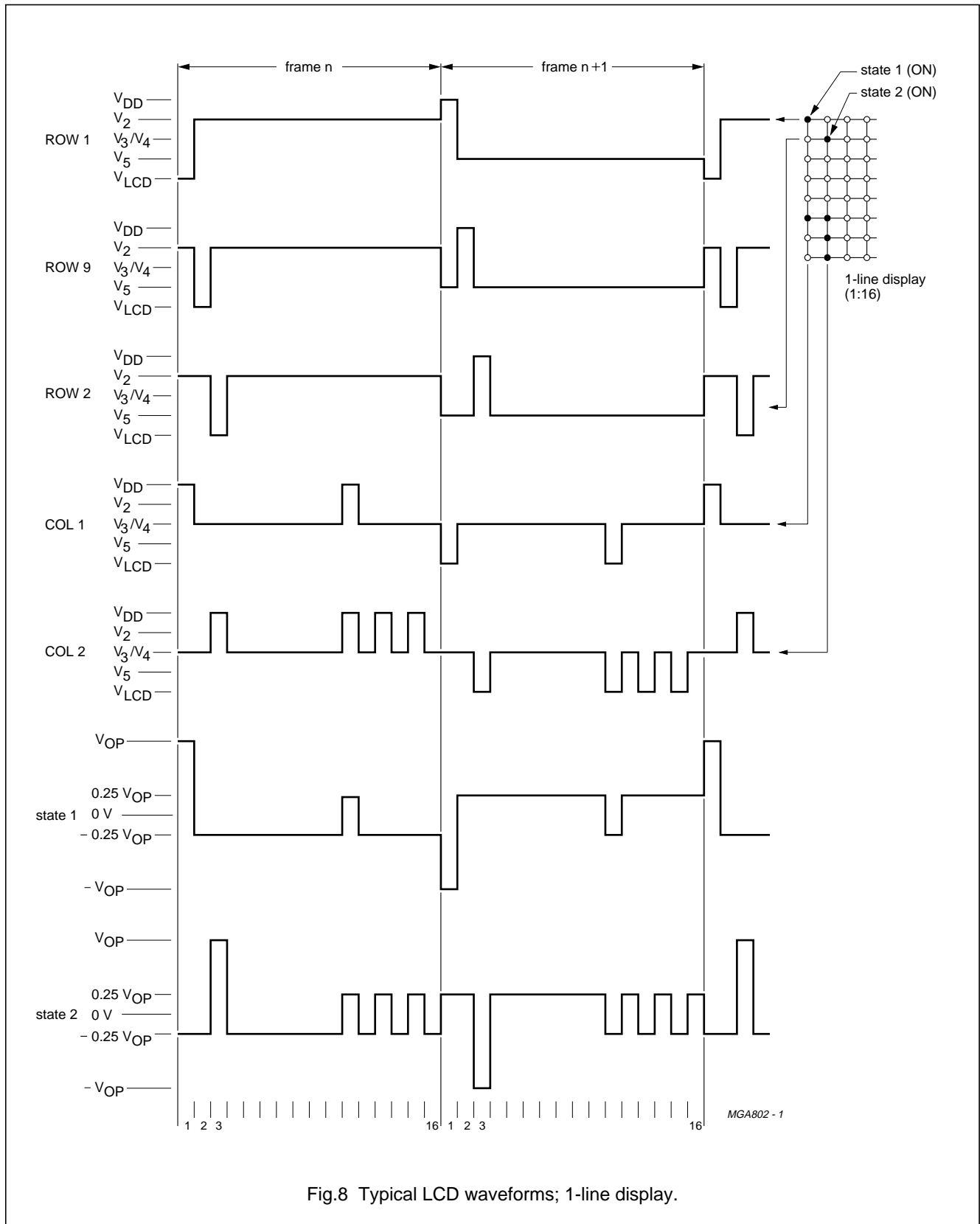

Fig.8 Typical LCD waveforms; 1-line display.

LCD controller/driver

PCF2105

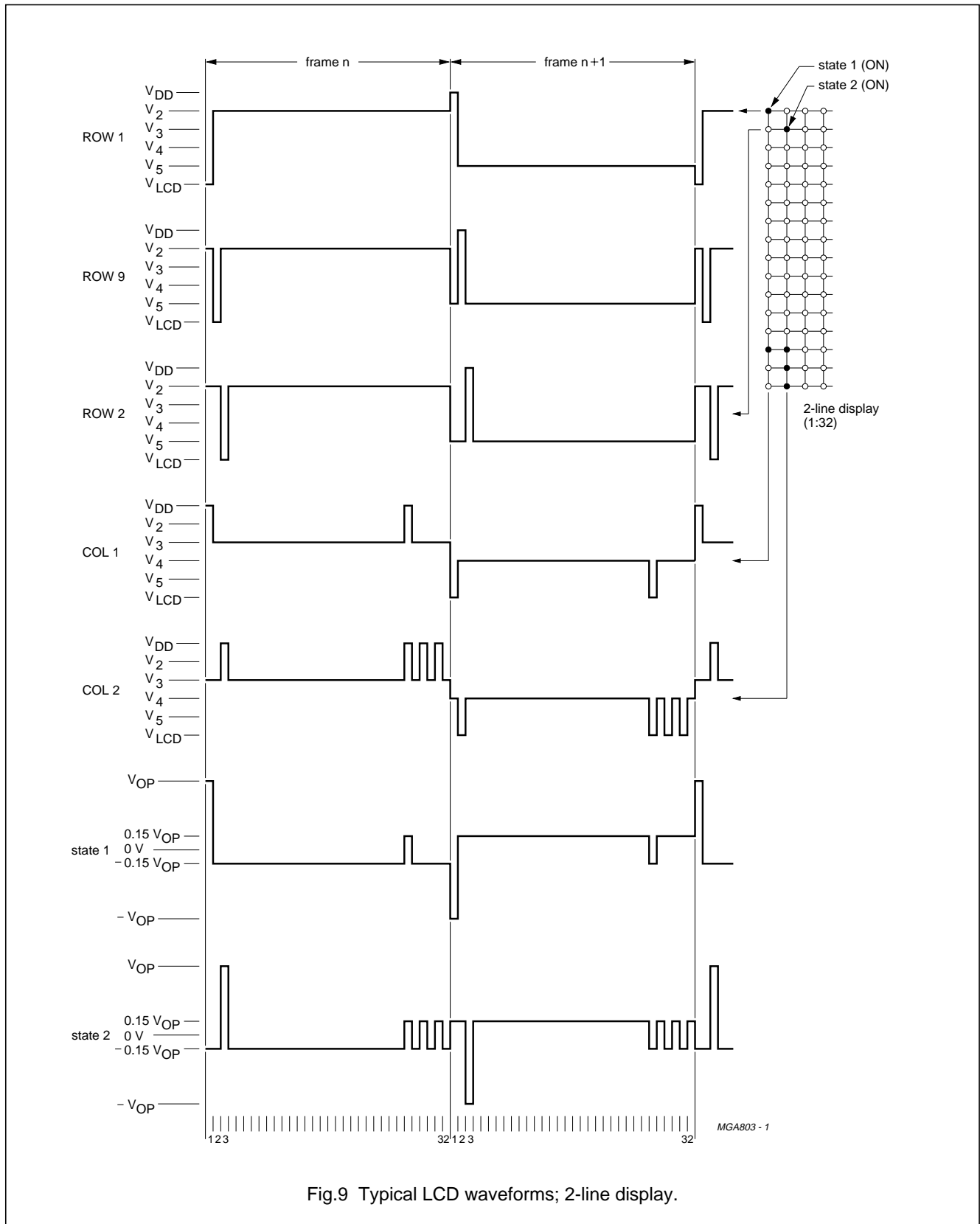

Fig.9 Typical LCD waveforms; 2-line display.

LCD controller/driver

PCF2105

**8.14 Programming of the MUX rate 1 : 16**

With the MUX rate 1 : 16 the PCF2105 can be used in the following ways:

- To drive a 1-line display of 24 characters
- To drive a 2-line display of 12 characters, resulting in better contrast. The internal data flow of the chip is optimized for this purpose.

To program the MUX rate 1 : 16, bits M and N of the 'function set' instruction must be set to logic 0 (see Table 3). Figures 10, 11 and 12 show the DDRAM addresses of the display characters. The second row of each figure corresponds to either the right half of a 1-line display or to the second line of a 2-line display. Wrap around of data during display shift or when writing data is non-standard.

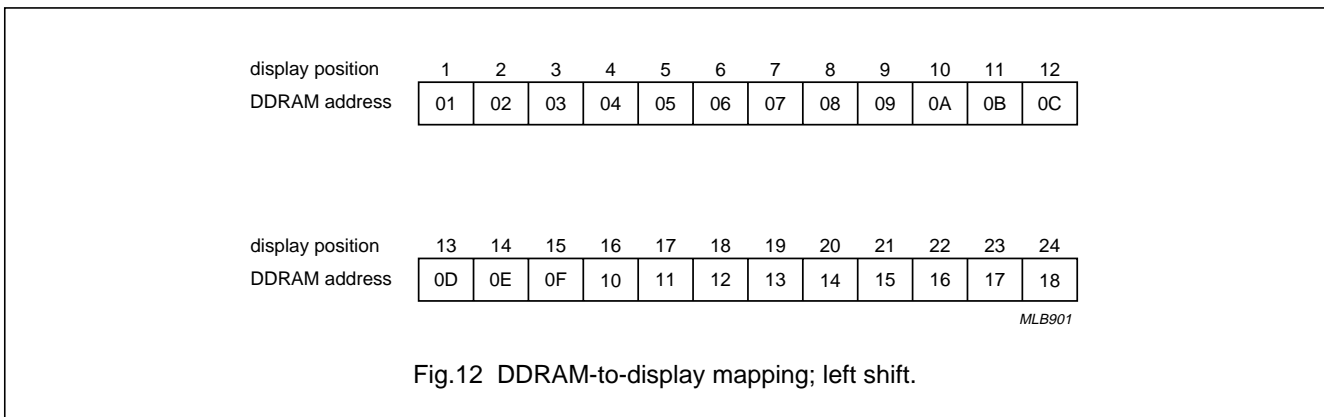
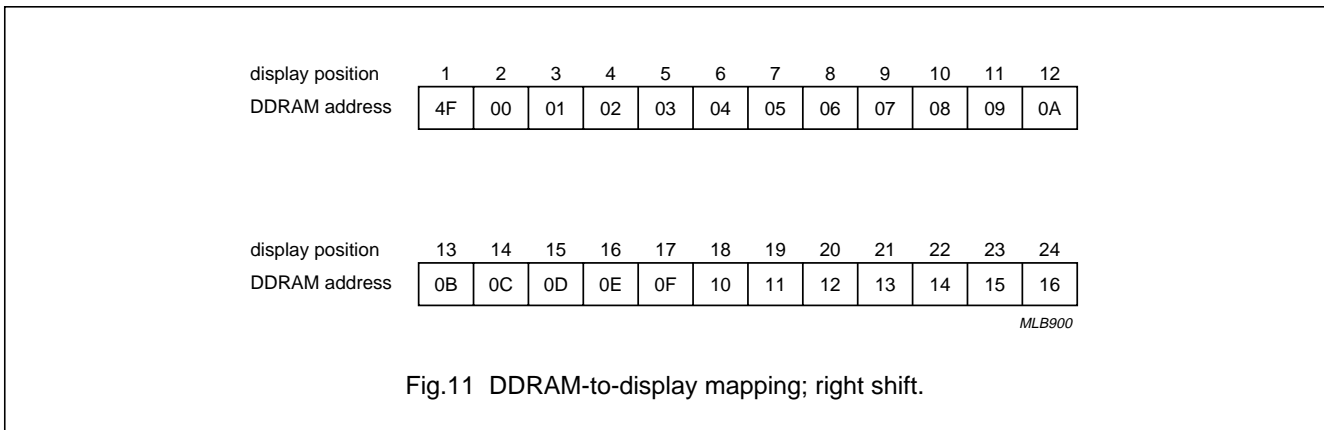
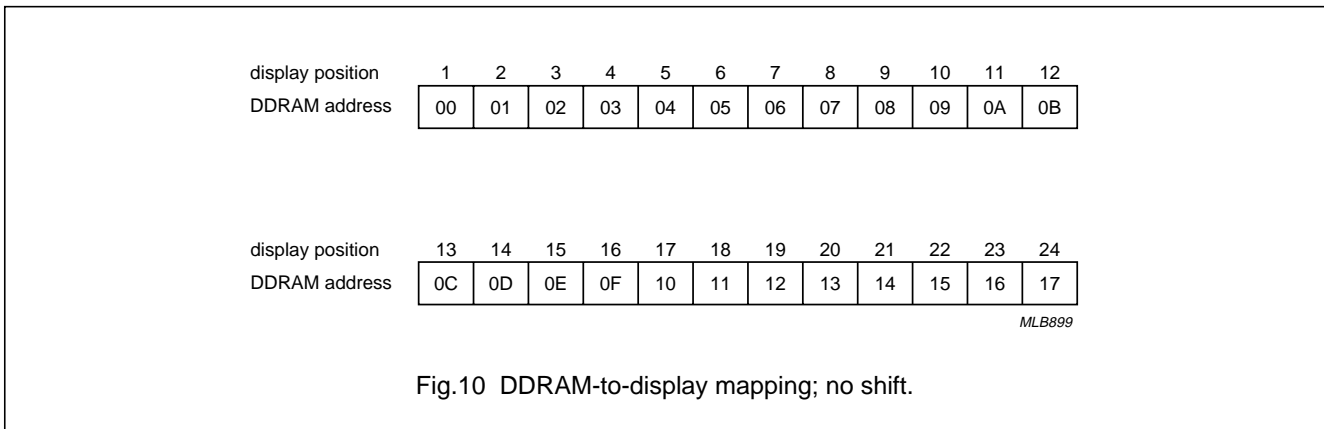

## LCD controller/driver

## PCF2105

**8.15 Programming of the MUX rate 1 : 32**

With the MUX rate 1 : 32 the PCF2105 can be used in the following ways:

- To drive a 2-line display of 24 characters, use instruction 'function set' to set bit M to logic 0 and bit N to logic 1
- To drive a 4-line display of 12 characters, use instruction 'function set' to set both bits M and N to logic 1.

**8.16 Reset function**

The PCF2105 automatically initializes (resets) when power is turned on. The state after reset is given in Table 2 (see Tables 3 and 4 for the description of the bits).

**Table 2** State after reset

STEP	DESCRIPTION
1	clear display
2	function set: bit DL = 1: 8-bit interface bits M and N = 0: 1-line display bit G = 0: not used
3	display control: bit D = 0: display off bit C = 0: cursor off bit B = 0: blink off
4	entry mode set: bit I/D = 1: +1(increment) bit G = 0: not used
5	default address pointer to DDRAM; the busy flag indicates the busy state (BF = 1) until initialization ends; the busy state lasts 2 ms; the chip may also be initialized by software; see Tables 10 and 11.
6	I <sup>2</sup> C-bus interface reset

**9 INSTRUCTIONS**

Only two PCF2105 registers, the Instruction Register (IR) and the Data Register (DR) can be directly controlled by the microcontroller. Before internal operation, control information is stored temporarily in these registers to allow interface to various types of microcontrollers which operate at different speeds or to allow interfacing to peripheral control ICs. The PCF2105 operation is controlled by the instructions shown in Table 3 together with their execution time. Details are explained in subsequent sections.

Instructions are of 4 categories, those that:

1. Designate PCF2105 functions such as display format, data length, etc.
2. Set internal RAM addresses
3. Perform data transfer with internal RAM
4. Others.

In normal use, category 3 instructions are used most frequently. However, automatic incrementing by 1 (or decrementing by 1) of internal RAM addresses after each data write lessens the microcontroller program load. The display shift in particular can be performed concurrently with display data write, thus enabling the designer to develop systems in minimum time with maximum programming efficiency.

During internal operation, no instruction other than the 'read busy flag and address' will be executed.

Because the busy flag is set to logic 1 while an instruction is being executed, it is advisable to ensure that the flag is set to logic 0 before sending the next instruction or wait for the maximum instruction execution time, as given in Table 3. An instruction sent while the busy flag is HIGH will not be executed.

**9.1 Clear display**

'Clear display' writes space code 20 (hexadecimal) into all DDRAM addresses (the character pattern for character code 20 must be a blank pattern), sets the DDRAM address counter to logic 0 and returns the display to its original position if it was shifted. Consequently, the display disappears and the cursor or blink position goes to the left edge of the display (the first line if 2 or 4 lines are displayed) and sets bit I/D of 'entry mode set' to logic 1 (increment mode). Bit S of 'entry mode set' does not change.

The instruction 'clear display' requires extra execution time. This may be allowed for checking the Busy Flag (BF) or by waiting until 2 ms has elapsed. The latter must be applied where no read-back options are available, as in some Chip-On-Glass (COG) applications.

**9.2 Return home**

'Return home' sets the DDRAM address counter to logic 0 and returns the display to its original position if it was shifted. DDRAM contents do not change. The cursor or blink position goes to the left of the display (the first line if 2 or 4 lines are displayed). Bits I/D and S of 'entry mode set' do not change.



## LCD controller/driver

## PCF2105

**Table 3** Instructions (note 1)

INSTRUCTION	RS	R/W	DB7	DB6	DB5	DB4	DB3	DB2	DB1	DB0	DESCRIPTION	REQUIRED CLOCK CYCLES <sup>(2)</sup>
NOP	0	0	0	0	0	0	0	0	0	0	no operation	0
Clear display	0	0	0	0	0	0	0	0	0	1	clears entire display and sets DDRAM address 00 in Address Counter (AC)	165
Return home	0	0	0	0	0	0	0	0	1	0	sets DDRAM address 00 in the AC; also returns shifted display to original position; DDRAM contents remain unchanged	3
Entry mode set	0	0	0	0	0	0	0	1	I/D	S	sets cursor move direction and specifies shift of display; these operations are performed during data write and read	3
Display control	0	0	0	0	0	0	1	D	C	B	sets entire display on/off (D), cursor on/off (C) and blink of cursor position character (B)	3
Cursor/display shift	0	0	0	0	0	1	S/C	R/L	0	0	moves cursor and shifts display without changing DDRAM contents	3
Function set	0	0	0	0	1	DL	N	M	G	0	sets interface data length (DL), number of display lines (N, M) and voltage generator control (G); bit G is not used	3
Set CGRAM address	0	0	0	1	A <sub>CG</sub>					sets CGRAM address	3	
Set DDRAM address	0	0	1	A <sub>DD</sub>					sets DDRAM address	3		
Read busy flag and address	0	1	BF	A <sub>C</sub>					reads BF indicating internal operation is being performed and reads AC contents	0		
Read data	1	1	read data					reads data from CGRAM or DDRAM	3			
Write data	1	0	write data					writes data to CGRAM or DDRAM	3			

**Notes**

- In the I<sup>2</sup>C-bus mode the DL bit is don't care. 8-bit mode is assumed. In the I<sup>2</sup>C-bus mode a control byte is required when bit RS or R/W is changed; control byte: Co, RS, R/W, 0, 0, 0, 0, 0; command byte: DB7 to DB0.
- Example:  $f_{osc} = 150 \text{ kHz}$ ,  $T_{cy} = \frac{1}{f_{osc}} = 6.67 \mu\text{s}$ ; 3 cycles = 20  $\mu\text{s}$ ; 165 cycles = 1.1 ms.

## LCD controller/driver

## PCF2105

**Table 4** Command bit identities, used in Table 3

BIT	LOGIC 0	LOGIC 1
I/D	decrement	increment
S	display freeze	display shift
D	display off	display on
C	cursor off	cursor on
B	character at cursor position does not blink	character at cursor position blinks
S/C	cursor move	display shift
R/L	left shift	right shift
DL	4 bits	8 bits
N (M = 0)	2 lines × 12 characters; MUX rate 1 : 16	2 lines × 24 characters; MUX rate 1 : 32
N (M = 1)	reserved	4 lines × 12 characters; MUX rate 1 : 32
BF	end of internal operation	internal operation in progress
Co	last control byte, only data bytes to follow	next two bytes are a data byte and another control byte

**9.3 Entry mode set**

## 9.3.1 I/D

When bit I/D = 1 (0), the DDRAM or CGRAM address increments (decrements) by 1 when data is written to or read from the DDRAM or CGRAM. The cursor or blink position moves to the right when incremented and to the left when decremented. The cursor and blink are inhibited when the CGRAM is accessed.

## 9.3.2 S

When bit S = 1, the entire display shifts either to the right (bit I/D = 0) or to the left (I/D = 1) during a DDRAM write. Consequently, it looks as if the cursor stands still and the display moves. The display does not shift when reading from the DDRAM, or when writing to or reading from the CGRAM. When S = 0 the display does not shift.

**9.4 Display control**

## 9.4.1 D

The display is on when bit D = 1 and off when D = 0. Display data in the DDRAM is not affected and can be displayed immediately by setting D to logic 1.

## 9.4.2 C

The cursor is displayed when bit C = 1 and inhibited when C = 0. Even if the cursor disappears, the display functions, I/D, etc. remain in operation during display data write. The cursor is displayed using 5 dots in the 8th line (see Fig.7).

## 9.4.3 B

The character indicated by the cursor blinks when bit B = 1. The blink is displayed by switching between display characters and all dots on with a period of 1 second when  $f_{osc} = 150 \text{ kHz}$  (see Fig.7). At other clock frequencies the blink period is equal to  $\frac{150 \text{ kHz}}{f_{osc}}$ .

The cursor and the blink can be set to display simultaneously.

**9.5 Cursor/display shift**

'Cursor/display shift' moves the cursor position or the display to the right or left without writing or reading display data. This function is used to correct a character or move the cursor through the display. In the 2 or 4-line display, the cursor moves to the next line when it passes the last position of the line (40 or 20 decimal). When the displayed data is shifted repeatedly all lines shift at the same time; displayed characters do not shift into the next line. The Address Counter (AC) content does not change if the only action performed is shift display, but increments or decrements with the cursor shift.

LCD controller/driver

PCF2105

**9.6 Function set**

**9.6.1 DL (PARALLEL MODE ONLY)**

Bit DL sets the interface data length. Data is sent or received in bytes (DB7 to DB0) when DL = 1 or in two nibbles (DB7 to DB4) when DL = 0. When 4-bit length is selected, data is transmitted in two cycles using the parallel bus. In a 4-bit application DB3 to DB0 are left open (internal pull-ups).

DL can not be set to logic 0 from the I<sup>2</sup>C-bus interface. If DL has been set to logic 0 via the parallel bus, programming via the I<sup>2</sup>C-bus interface is complicated.

**9.6.2 N AND M**

Bits N and M set the number of display lines.

**9.7 Set CGRAM address**

‘Set CGRAM address’ sets bits 0 to 5 of the CGRAM address (A<sub>CG</sub> in Table 3) into the AC (binary A[5] to A[0]). Data can then be written to or read from the CGRAM.

Only bits 0 to 5 of the CGRAM address are set by the ‘set CGRAM address’ instruction. Bit 6 can be set using the ‘set DDRAM address’ instruction or by using the auto-increment feature during CGRAM write. All bits 0 to 6 can be read using the ‘read busy flag and address’ instruction.

**9.8 Set DDRAM address**

‘Set DDRAM address’ sets the DDRAM address (A<sub>DD</sub> in Table 3) into the AC (binary A[6] to A[0]). Data can then be written to or read from the DDRAM.

**Table 5** Hexadecimal address ranges

ADDRESS	FUNCTION
00 to 4F	1 line of 24 characters
00 to 0B and 0C to 4F	2 lines of 12 characters
00 to 27 and 40 to 67	2 lines of 24 characters
00 to 13, 20 to 33, 40 to 53 and 60 to 73	4 lines of 12 characters

**9.9 Read busy flag and address**

‘Read busy flag and address’ reads the Busy Flag (BF). When bit BF = 1 it indicates that an internal operation is in progress. The next instruction will not be executed until BF = 0, so BF should be checked before sending another instruction.

At the same time, the value of the AC expressed in binary A[6] to A[0] is read out. The address counter is used by both CGRAM and DDRAM and its value is determined by the previous instruction.

**9.10 Write data to CGRAM or DDRAM**

‘Write data’ writes binary 8-bit data (D[7] to D[0]) to the CGRAM or the DDRAM.

Whether the CGRAM or DDRAM is to be written to is determined by the previous specification of CGRAM or DDRAM address setting. After writing, the address automatically increments or decrements by 1, in accordance with the ‘entry mode set’.

Only bits D[4] to D[0] of CGRAM data are valid, bits D[7] to D[5] are ‘don’t care’.

**9.11 Read data from CGRAM or DDRAM**

‘Read data’ reads binary 8-bit data D[7] to D[0] from the CGRAM or DDRAM.

The most recent ‘set address’ instruction determines whether the CGRAM or DDRAM is to be read.

The ‘read data’ instruction gates the content of the Data Register (DR) to the bus while pad E = HIGH. After E goes LOW again, internal operation increments (or decrements) the AC and stores RAM data corresponding to the new AC into the DR.

Remark: the only three instructions that update the DR are:

- ‘Set CGRAM address’
- ‘Set DDRAM address’
- ‘Read data’ from CGRAM or DDRAM.

Other instructions (e.g. ‘write data’, ‘cursor/display shift’, ‘clear display’, ‘return home’) will not change the data register content.

# LCD controller/driver

# PCF2105

## 10 INTERFACE TO MICROCONTROLLER (PARALLEL INTERFACE)

The PCF2105 can send data in either two 4-bit modes or one 8-bit mode and can thus interface to 4 or 8-bit microcontrollers.

In the 8-bit mode data is transferred as 8-bit bytes using the 8 data lines DB7 to DB0. The control lines E, RS, and R/W are required.

In the 4-bit mode data is transferred in two cycles of 4-bits each. The higher order bits (corresponding to DB7 to DB4

in 8-bit mode) are sent in the first cycle and the lower order bits (DB3 to DB0 in 8-bit mode) in the second cycle. Data transfer is complete after two 4-bit data transfers. It should be noted that two cycles are also required for the busy flag check. The 4-bit mode is selected by instruction. See Figs 13, 14 and 15 for examples of bus protocol.

In the 4-bit mode, the pads DB3 to DB0 must be left open-circuit. They are pulled up to V<sub>DD</sub> internally.

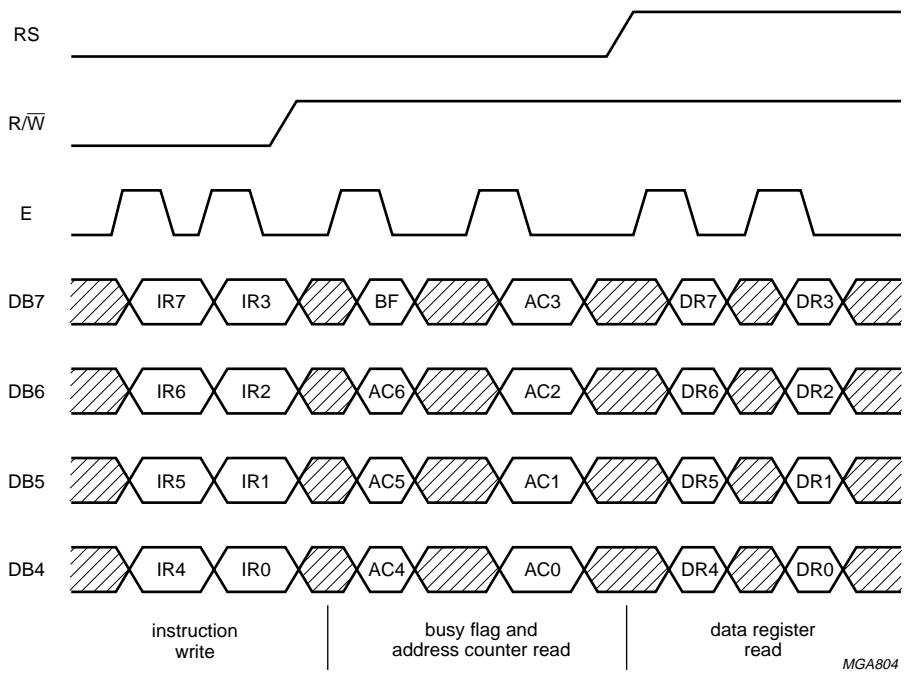
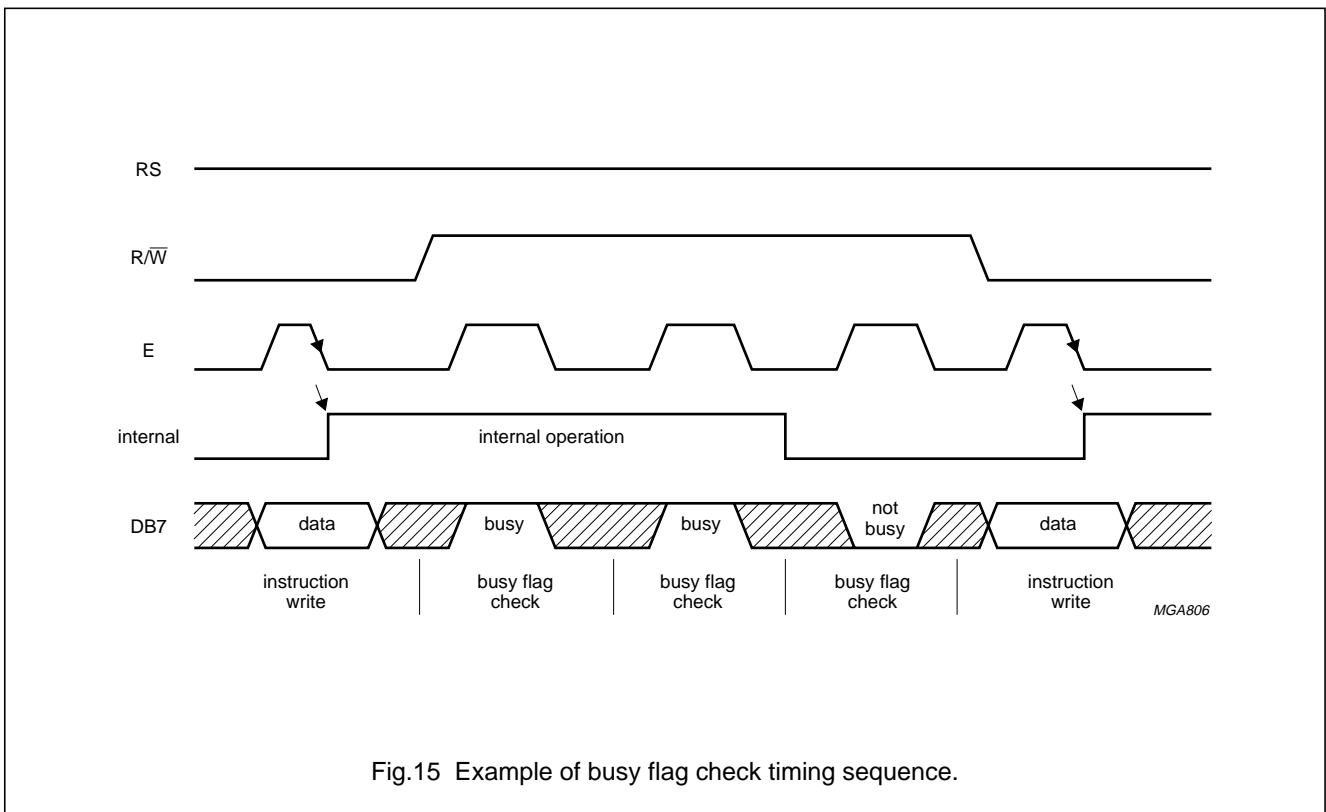
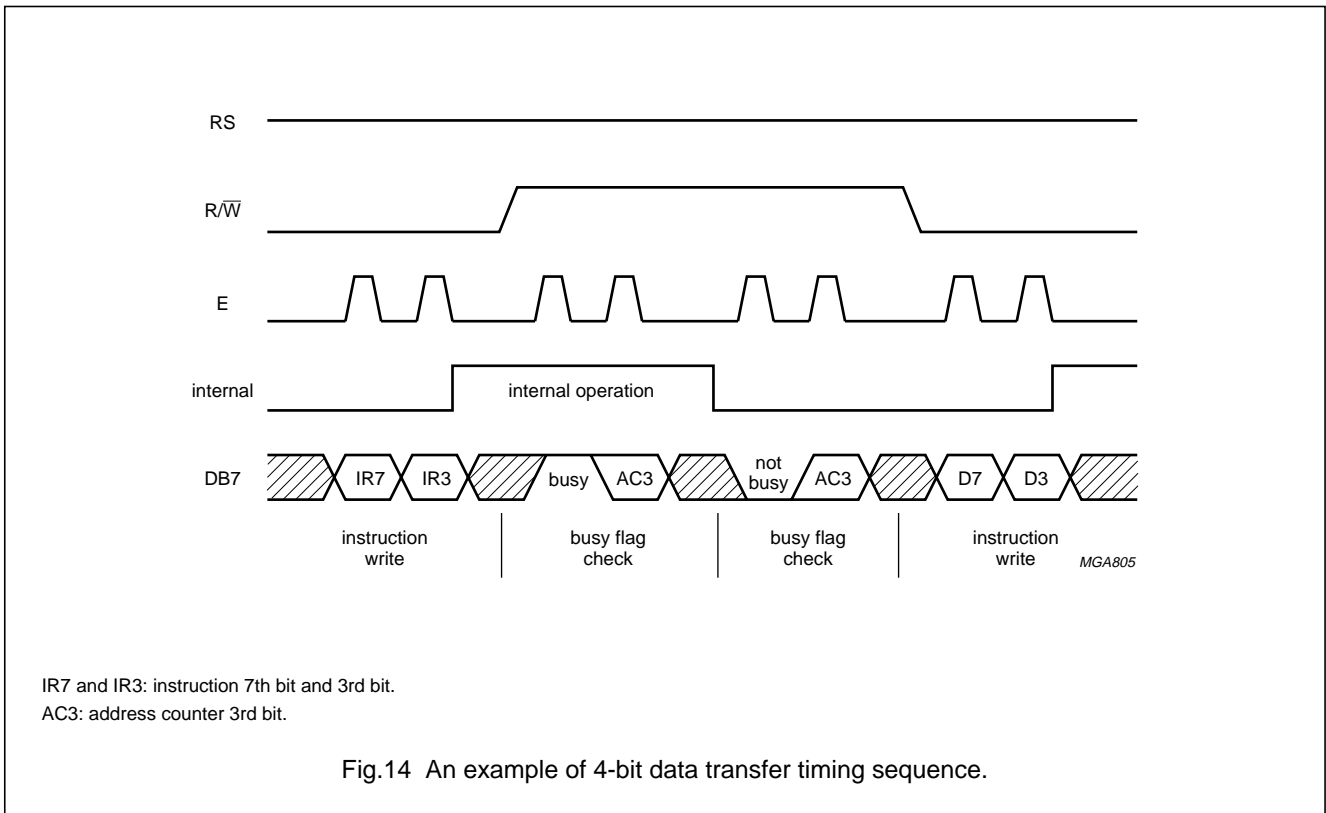

Fig.13 4-bit transfer example.

LCD controller/driver

PCF2105



LCD controller/driver

PCF2105

**11 INTERFACE TO MICROCONTROLLER (I<sup>2</sup>C-BUS INTERFACE)**

**11.1 Characteristics of the I<sup>2</sup>C-bus**

The I<sup>2</sup>C-bus is for bidirectional, 2-line communication between different ICs or modules. The 2 lines are a serial data line (SDA) and a serial clock line (SCL). Both lines must be connected to a positive supply via a pull-up resistor. Data transfer may be initiated only when the bus is not busy.

**11.2 Bit transfer**

One data bit is transferred during each clock pulse. The data on the SDA line must remain stable during the HIGH-level period of the clock pulse as changes in the data line at this time will be interpreted as a control signal (see Fig.16).

**11.3 START and STOP conditions**

Both data and clock lines remain HIGH when the bus is not busy. A HIGH-to-LOW transition of the data line, while the clock is HIGH is defined as the START condition (S). A LOW-to-HIGH transition of the data line while the clock is HIGH is defined as the STOP condition (P) (see Fig.17).

**11.4 System configuration**

A device generating a message is a transmitter, a device receiving a message is the receiver. The device that controls the message is the master and the devices which are controlled by the master are the slaves (see Fig.18).

**11.5 Acknowledge**

The number of data bytes transferred between the START and STOP conditions from transmitter to receiver is unlimited. Each byte of 8 bits is followed by an acknowledge bit. The acknowledge bit is a HIGH signal put on the bus by the transmitter during which time the master generates an extra acknowledge related clock pulse. A slave receiver which is addressed must generate an acknowledge after the reception of each byte. Also a master receiver must generate an acknowledge after the reception of each byte that has been clocked out of the slave transmitter. The device that acknowledges must pull-down the SDA line during the acknowledge clock pulse, so that the SDA line is stable LOW during the HIGH period of the acknowledge related clock pulse (set-up and hold times must be taken into consideration). A master receiver must signal an end of data to the transmitter by not generating an acknowledge on the last byte that has been clocked out of the slave. In this event the transmitter must leave the data line HIGH to enable the master to generate a STOP condition (see Fig.19).

**11.6 I<sup>2</sup>C-bus protocol**

Before any data is transmitted on the I<sup>2</sup>C-bus, the device which should respond is addressed first. The addressing is always carried out with the first byte transmitted after the start procedure. The I<sup>2</sup>C-bus configuration for the different PCF2105 read and write cycles is illustrated in Figs 20, 21 and 22.

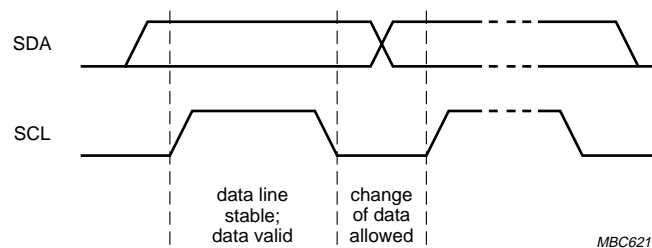
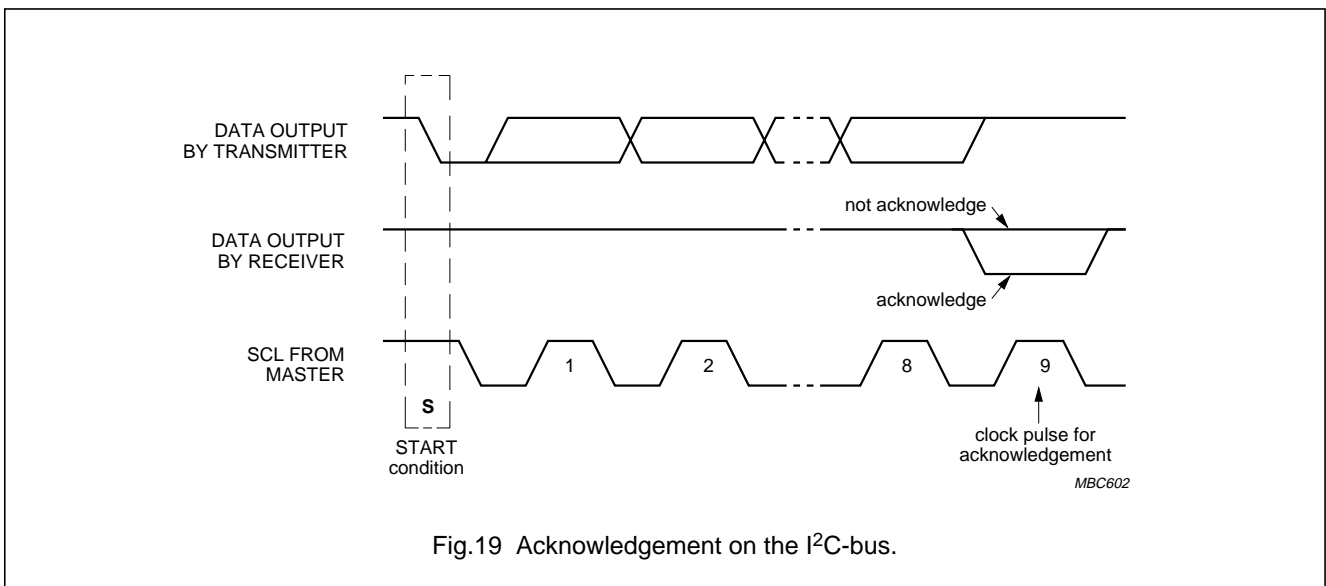
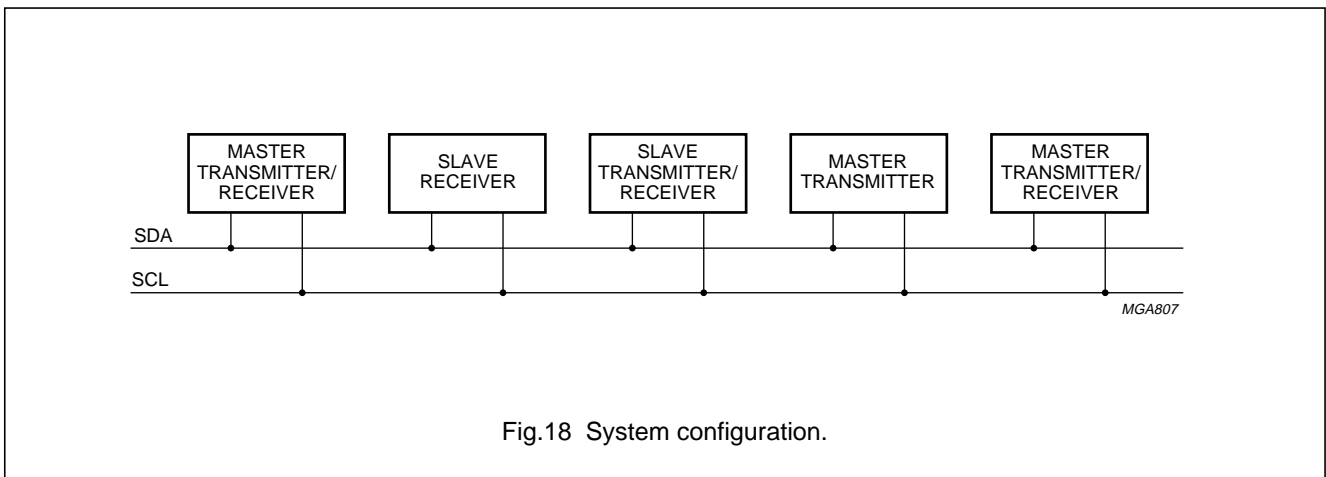
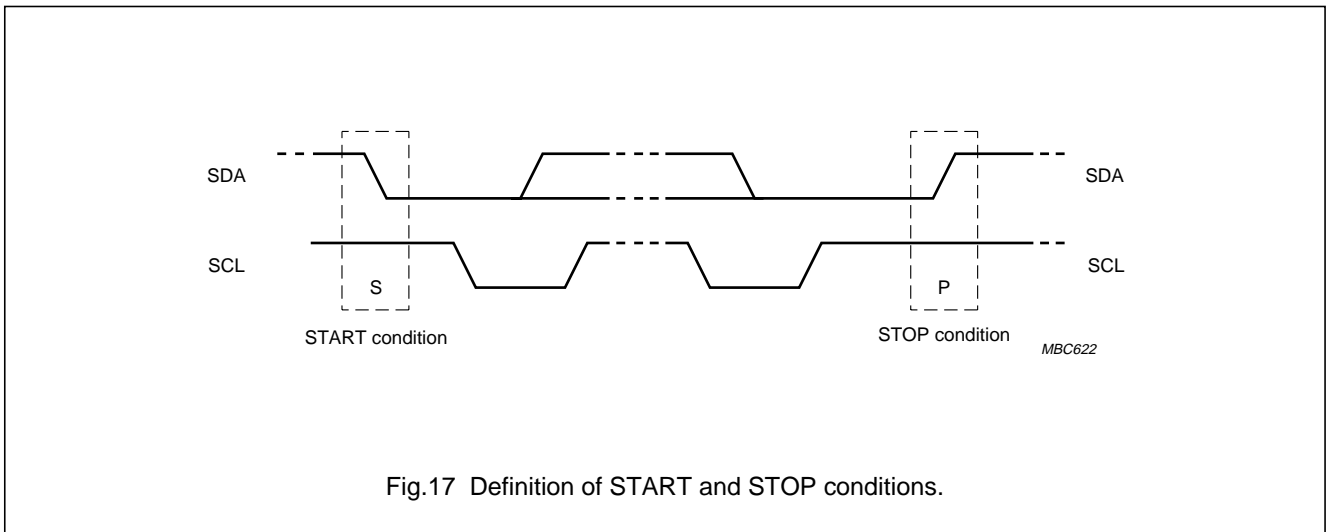

Fig.16 Bit transfer.

LCD controller/driver

PCF2105



LCD controller/driver

PCF2105

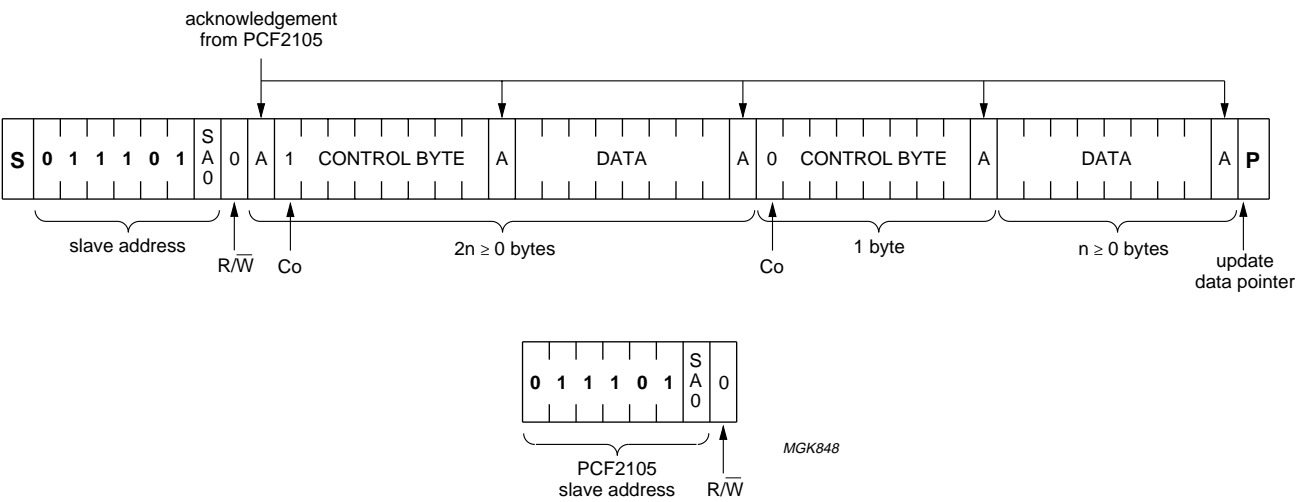
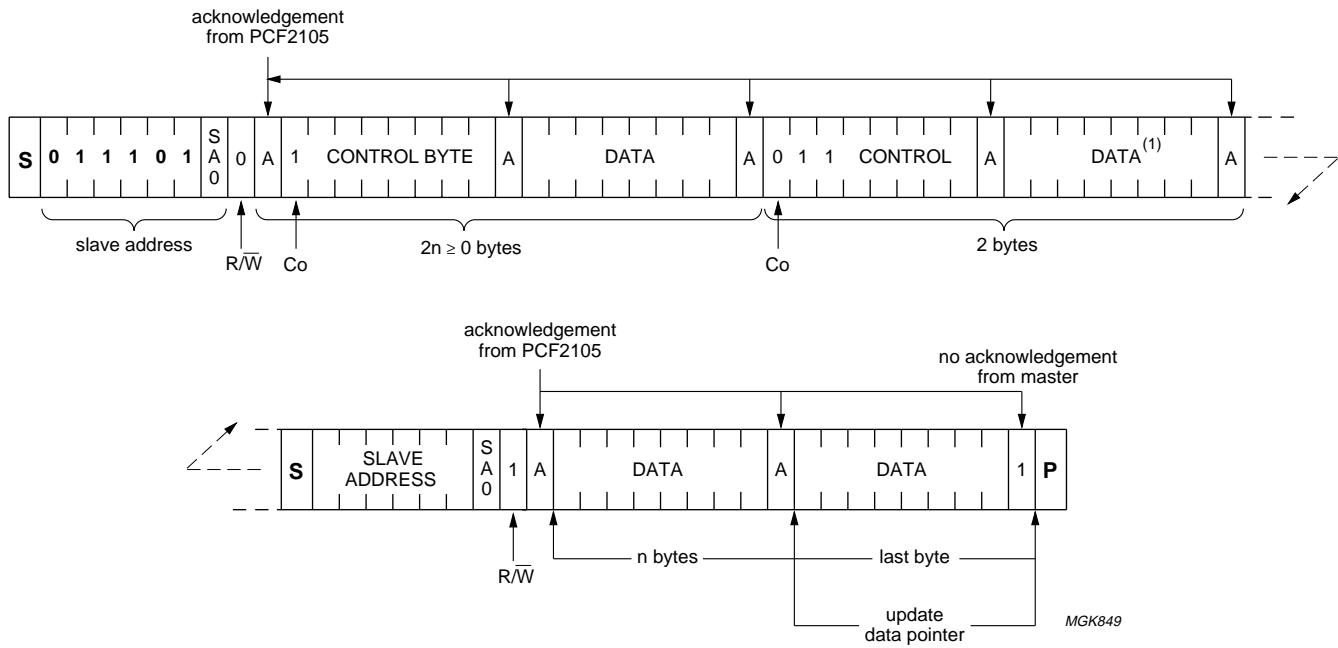

Fig.20 Master transmits to slave receiver; write mode.



LCD controller/driver

PCF2105



(1) Last data byte is a dummy byte (may be omitted).

Fig.21 Master reads after setting word address; write word address, set RS and R $\bar{W}$ ; read data.

LCD controller/driver

PCF2105

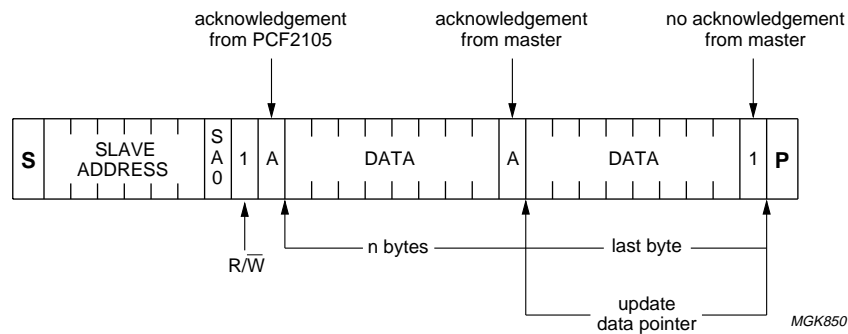

Fig.22 Master reads slave immediately after first byte; read mode (RS previously defined).

12 LIMITING VALUES

In accordance with the Absolute Maximum Rating System (IEC 134).

SYMBOL	PARAMETER	MIN.	MAX.	UNIT
$V_{DD}$	logic supply voltage	-0.5	+8.0	V
$V_{LCD}$	LCD supply voltage	$V_{DD} - 11$	$V_{DD}$	V
$V_{I(n)}$	input voltage on pads OSC, RS, R/W, E and DB0 to DB7	$V_{SS} - 0.5$	$V_{DD} + 0.5$	V
$V_{O(n)}$	output voltage on pads R1 to R32, C1 to C60 and $V_{LCD}$	$V_{LCD} - 0.5$	$V_{DD} + 0.5$	V
$I_{I(n)}$	DC input current on every pad	-10	+10	mA
$I_{O(n)}$	DC output current on every pad	-10	+10	mA
$I_n$	current on $V_{DD}$ , $V_{SS}$ and $V_{LCD}$	-50	+50	mA
$P_{tot}$	total power dissipation	-	400	mW
$P/out$	power dissipation per output	-	100	mW
$T_{stg}$	storage temperature	-65	+150	°C

13 HANDLING

Inputs and outputs are protected against electrostatic discharge in normal handling. However, to be totally safe, it is desirable to take normal precautions appropriate to handling MOS devices (see "Handling MOS Devices").

## LCD controller/driver

## PCF2105

**14 DC CHARACTERISTICS**

$V_{DD} = 2.5$  to  $6$  V;  $V_{SS} = 0$  V;  $V_{LCD} = V_{DD} - 3.5$  to  $V_{DD} - 9$  V;  $T_{amb} = -40$  to  $+85$  °C; unless otherwise specified.

SYMBOL	PARAMETER	CONDITIONS	MIN.	TYP.	MAX.	UNIT
<b>Supplies</b>						
$V_{DD}$	logic supply voltage		2.5	–	6.0	V
$V_{LCD}$	LCD supply voltage		$V_{DD} - 9$	–	$V_{DD} - 3.5$	V
$I_{DD(ext)}$	external supply current	note 1	–	200	500	$\mu$ A
		$V_{DD} = 5$ V; $V_{OP} = 9$ V; $f_{osc} = 150$ kHz; $T_{amb} = 25$ °C	–	200	300	$\mu$ A
		$V_{DD} = 3$ V; $V_{OP} = 5$ V; $f_{osc} = 150$ kHz; $T_{amb} = 25$ °C	–	150	200	$\mu$ A
$I_{I(LCD)}$	input current on $V_{LCD}$	note 1	–	50	100	$\mu$ A
$V_{POR}$	Power-on reset voltage level	note 2	–	1.3	1.8	V
<b>Logic</b>						
$V_{IL}$	LOW-level input voltage on pads E, RS, $R/\bar{W}$ , DB7 to DB0 and SA0		$V_{SS}$	–	$0.3V_{DD}$	V
$V_{IH}$	HIGH-level input voltage on pads E, RS, $R/\bar{W}$ , DB7 to DB0 and SA0		$0.7V_{DD}$	–	$V_{DD}$	V
$V_{IL(OSC)}$	LOW-level input voltage on pad OSC		$V_{SS}$	–	$V_{DD} - 1.5$	V
$V_{IH(OSC)}$	HIGH-level input voltage on pad OSC		$V_{DD} - 0.1$	–	$V_{DD}$	V
$I_{pu}$	pull-up current on pads DB7 to DB0, RS and $R/\bar{W}$	pads set to logic 0 ( $V_{SS}$ )	0.04	0.15	1.00	$\mu$ A
$I_{OL(DB)}$	LOW-level output current on pads DB7 to DB0	$V_{OL} = 0.4$ V; $V_{DD} = 5$ V	1.6	–	–	mA
$I_{OH(DB)}$	HIGH-level output current on pads DB7 to DB0	$V_{OH} = 4$ V; $V_{DD} = 5$ V	–1.0	–	–	mA
$I_L$	leakage current on pads DB7 to DB0, OSC, E, RS, $R/\bar{W}$ and SA0	pads set to logic 0 ( $V_{SS}$ ) or logic 1 ( $V_{DD}$ )	–1	–	+1	$\mu$ A
<b>I<sup>2</sup>C-bus</b>						
SDA and SCL						
$V_{IL}$	LOW-level input voltage	note 3	$V_{SS}$	–	$0.3V_{DD}$	V
$V_{IH}$	HIGH-level input voltage	note 3	$0.7V_{DD}$	–	$V_{DD}$	V
$I_L$	leakage current	pads set to logic 0 ( $V_{SS}$ ) or logic 1 ( $V_{DD}$ )	–1	–	+1	$\mu$ A
$C_i$	input capacitance	note 4	–	–	7	pF
$I_{OL(SDA)}$	LOW-level output current on SDA	$V_{OL} = 0.4$ V; $V_{DD} = 5$ V	3	–	–	mA

## LCD controller/driver

## PCF2105

SYMBOL	PARAMETER	CONDITIONS	MIN.	TYP.	MAX.	UNIT
<b>LCD outputs</b>						
$R_{o(ROW)}$	row output resistance on pads R32 to R1	note 5	–	1.5	3	$k\Omega$
$R_{o(COL)}$	column output resistance on pads C60 to C1	note 5	–	3	6	$k\Omega$
$V_{bias(tol)}$	bias voltage tolerance on pads R32 to R1 and C60 to C1	note 6	–	$\pm 20$	$\pm 130$	mV

**Notes**

- LCD outputs are open-circuit; inputs at  $V_{DD}$  or  $V_{SS}$ ; bus inactive; internal or external clock with duty factor 50%.
- Resets all logic when  $V_{DD} < V_{POR}$ .
- When the voltages are above  $V_{DD}$  or below  $V_{SS}$ , an input current may flow; this current must not exceed  $\pm 0.5$  mA.
- Tested on sample basis.
- Resistance of output terminals (R32 to R1 and C60 to C1) with load current  $I_L = 150 \mu A$ ;  $V_{OP} = V_{DD} - V_{LCD} = 9$  V; outputs measured one at a time.
- LCD outputs open-circuit.

**15 AC CHARACTERISTICS**

$V_{DD} = 2.5$  to  $6.0$  V;  $V_{SS} = 0$  V;  $V_{LCD} = V_{DD} - 3.5$  V to  $V_{DD} - 9$  V;  $T_{amb} = -40$  to  $+85$  °C; unless otherwise specified.

SYMBOL	PARAMETER	CONDITIONS	MIN.	TYP.	MAX.	UNIT
$f_{fr(LCD)}$	LCD frame frequency (internal clock)	note 1	40	65	100	Hz
$f_{osc}$	oscillator frequency (external clock)		90	150	225	kHz
<b>Bus timing characteristics: Parallel Interface; notes 1 and 2</b>						
WRITE OPERATION (WRITING DATA FROM MICROCONTROLLER TO PCF2105); see Fig.23						
$T_{cy(en)}$	enable cycle time		500	–	–	ns
$t_{W(en)}$	enable pulse width		220	–	–	ns
$t_{su(A)}$	address set-up time		50	–	–	ns
$t_{h(A)}$	address hold time		25	–	–	ns
$t_{su(D)}$	data set-up time		60	–	–	ns
$t_{h(D)}$	data hold time		25	–	–	ns
READ OPERATION (READING DATA FROM PCF2105 TO MICROCONTROLLER); see Fig.24						
$T_{cy(en)}$	enable cycle time		500	–	–	ns
$t_{W(en)}$	enable pulse width		220	–	–	ns
$t_{su(A)}$	address set-up time		50	–	–	ns
$t_{h(A)}$	address hold time		25	–	–	ns
$t_{d(D)}$	data delay time		–	–	150	ns
$t_{h(D)}$	data hold time		20	–	100	ns

## LCD controller/driver

## PCF2105

SYMBOL	PARAMETER	CONDITIONS	MIN.	TYP.	MAX.	UNIT
<b>Timing characteristics: I<sup>2</sup>C-bus interface; note 2; see Fig.25</b>						
f <sub>SCL</sub>	SCL clock frequency		–	–	400	kHz
t <sub>SW</sub>	tolerable spike width on bus		–	–	50	ns
t <sub>BUF</sub>	bus free time		1.3	–	–	μs
t <sub>SU;STA</sub>	set-up time for a repeated START condition		0.6	–	–	μs
t <sub>HD;STA</sub>	START condition hold time		0.6	–	–	μs
t <sub>LOW</sub>	SCL LOW time		1.3	–	–	μs
t <sub>HIGH</sub>	SCL HIGH time		0.6	–	–	μs
t <sub>r</sub>	SCL and SDA rise time	note 3	–	20 + RC <sub>L</sub>	300	ns
t <sub>f</sub>	SCL and SDA fall time	note 3	–	20 + RC <sub>L</sub>	300	ns
t <sub>SU;DAT</sub>	data set-up time	note 4	100	–	–	ns
t <sub>HD;DAT</sub>	data hold time	notes 5 and 6	0	–	0.9	μs
t <sub>SU;STO</sub>	set-up time for STOP condition		0.6	–	–	μs
C <sub>L</sub>	load capacitance for each bus line		–	–	400	pF

**Notes**

1. V<sub>DD</sub> = 5.0 V.
2. All timing values are valid within the operating supply voltage and ambient temperature range and are referenced to V<sub>IL</sub> and V<sub>IH</sub> with an input voltage swing of V<sub>SS</sub> to V<sub>DD</sub>.
3. C<sub>L</sub> = total capacitance of one bus line in pF and R = 100 Ω.
4. A fast mode I<sup>2</sup>C-bus device can be used in a standard-mode I<sup>2</sup>C-bus system, but the requirement t<sub>SU;DAT</sub> ≥ 250 ns must then be met. This will automatically be the case if the device does not stretch the LOW period of the SCL signal. If such a device does stretch the LOW period of the SCL signal, it must output the next data bit to the SDA line t<sub>r(max)</sub> + t<sub>SU;DAT</sub> = 1000 + 250 = 1250 ns (according to the standard-mode I<sup>2</sup>C-bus specification) before the SCL line is released.
5. A device must internally provide a hold time of at least 300 ns for the SDA signal (referred to the V<sub>IH(min)</sub> of the SCL signal) in order to bridge the undefined region of the falling edge of SCL.
6. The maximum t<sub>HD;DAT</sub> has only to be met if the device does not stretch t<sub>LOW</sub> of the SCL signal.

LCD controller/driver

PCF2105

16 TIMING DIAGRAMS

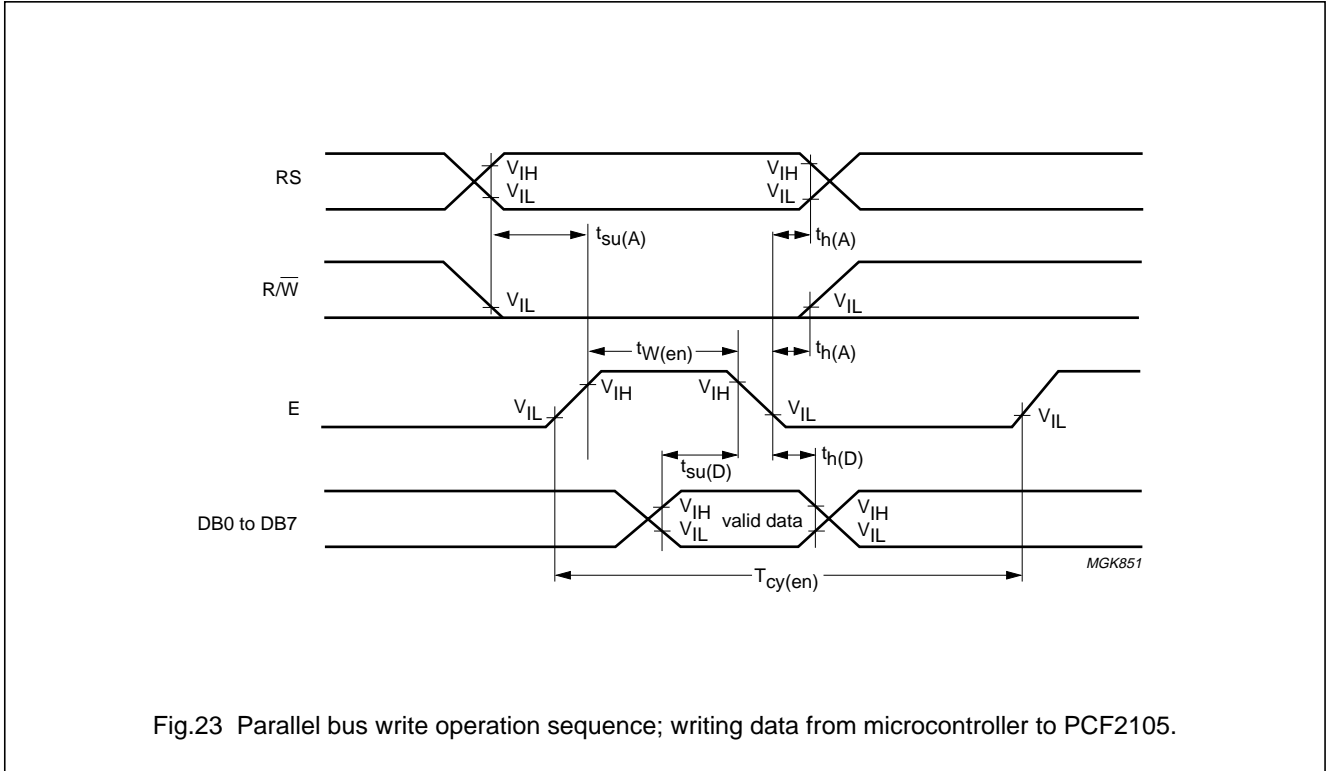

Fig.23 Parallel bus write operation sequence; writing data from microcontroller to PCF2105.

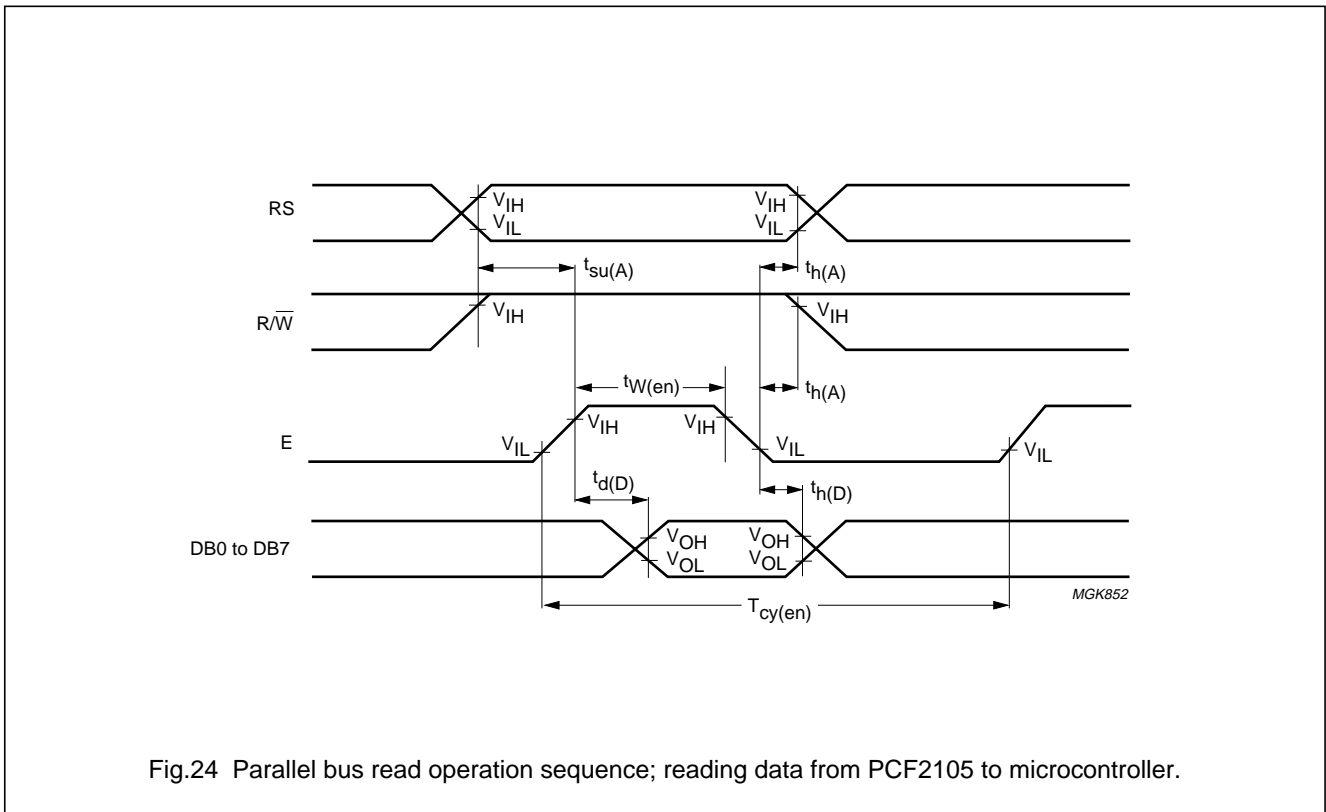

Fig.24 Parallel bus read operation sequence; reading data from PCF2105 to microcontroller.

LCD controller/driver

PCF2105

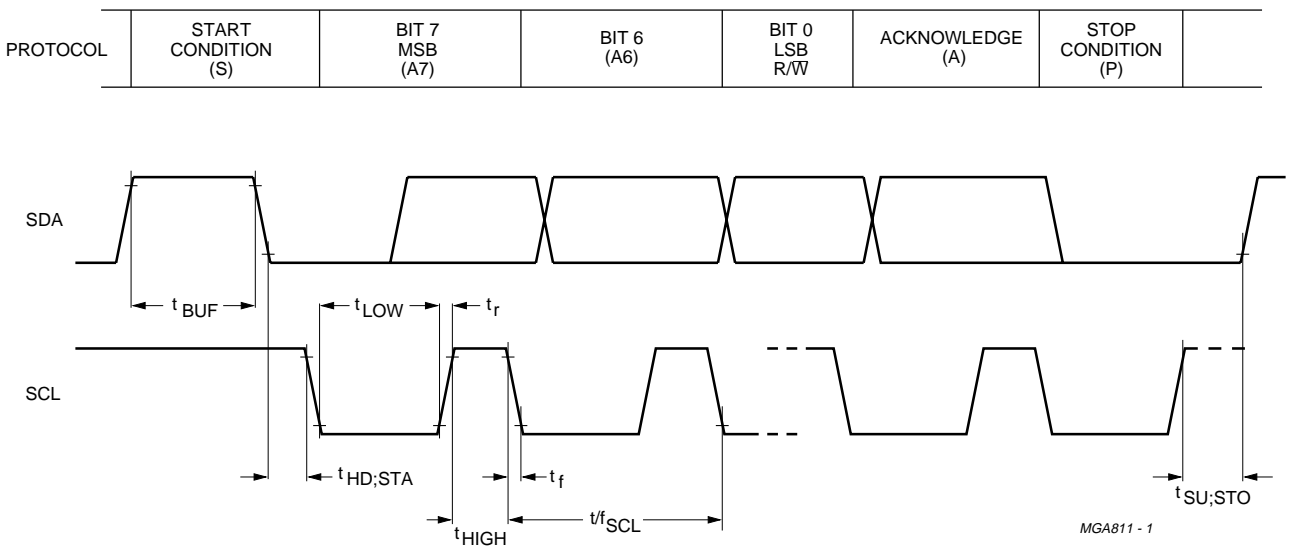

Fig.25 I<sup>2</sup>C-bus timing diagram; rise and fall times refer to V<sub>IL</sub> and V<sub>IH</sub>.

LCD controller/driver

PCF2105

17 APPLICATION INFORMATION

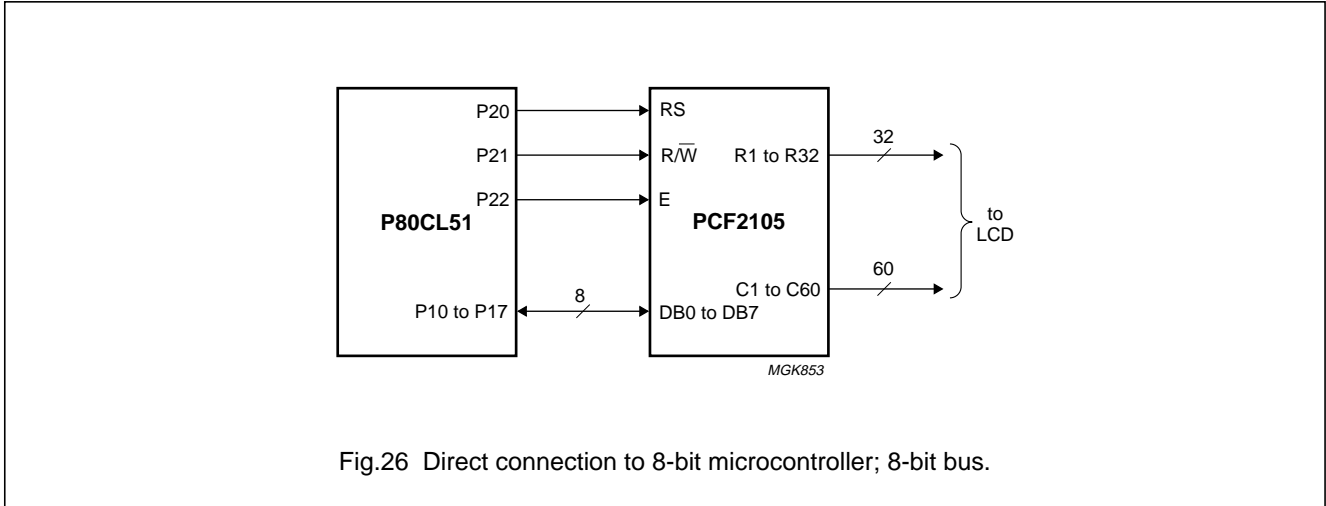

Fig.26 Direct connection to 8-bit microcontroller; 8-bit bus.

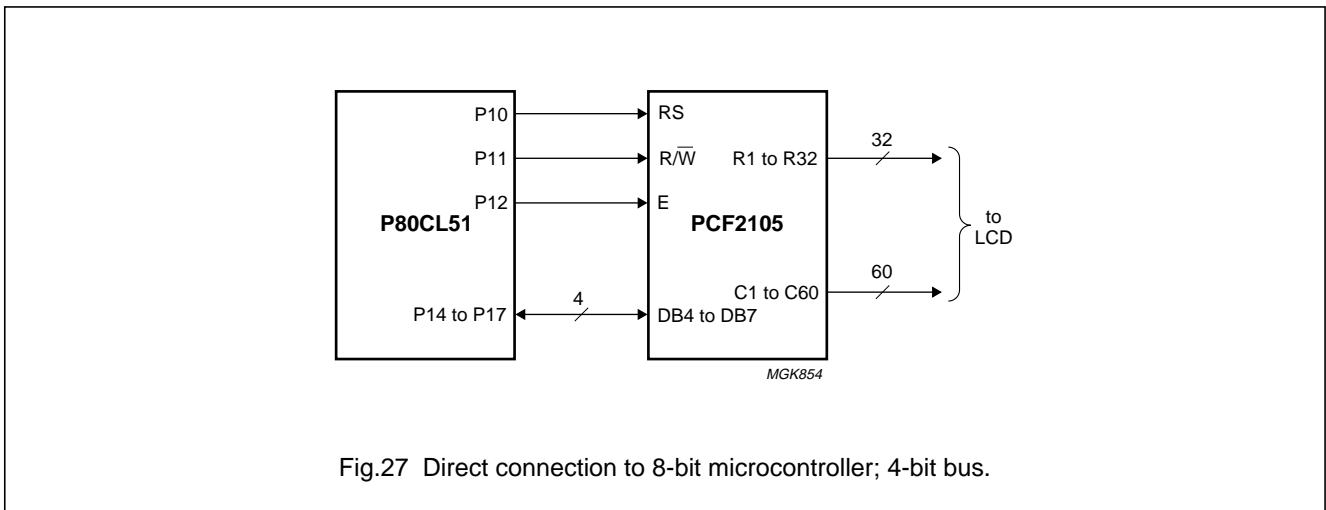

Fig.27 Direct connection to 8-bit microcontroller; 4-bit bus.

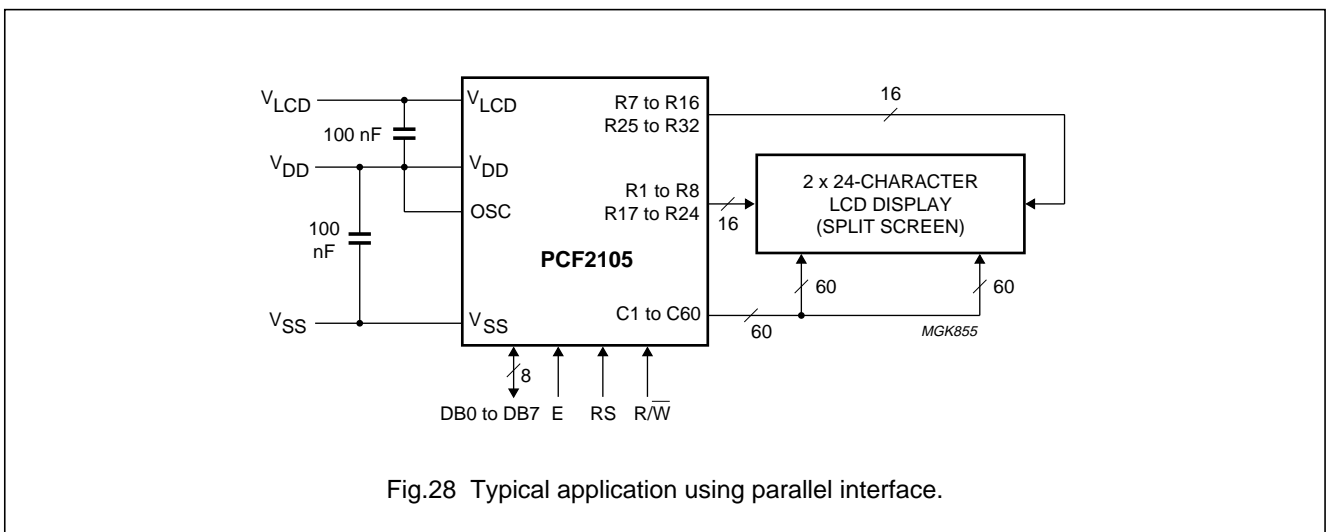

Fig.28 Typical application using parallel interface.



LCD controller/driver

PCF2105

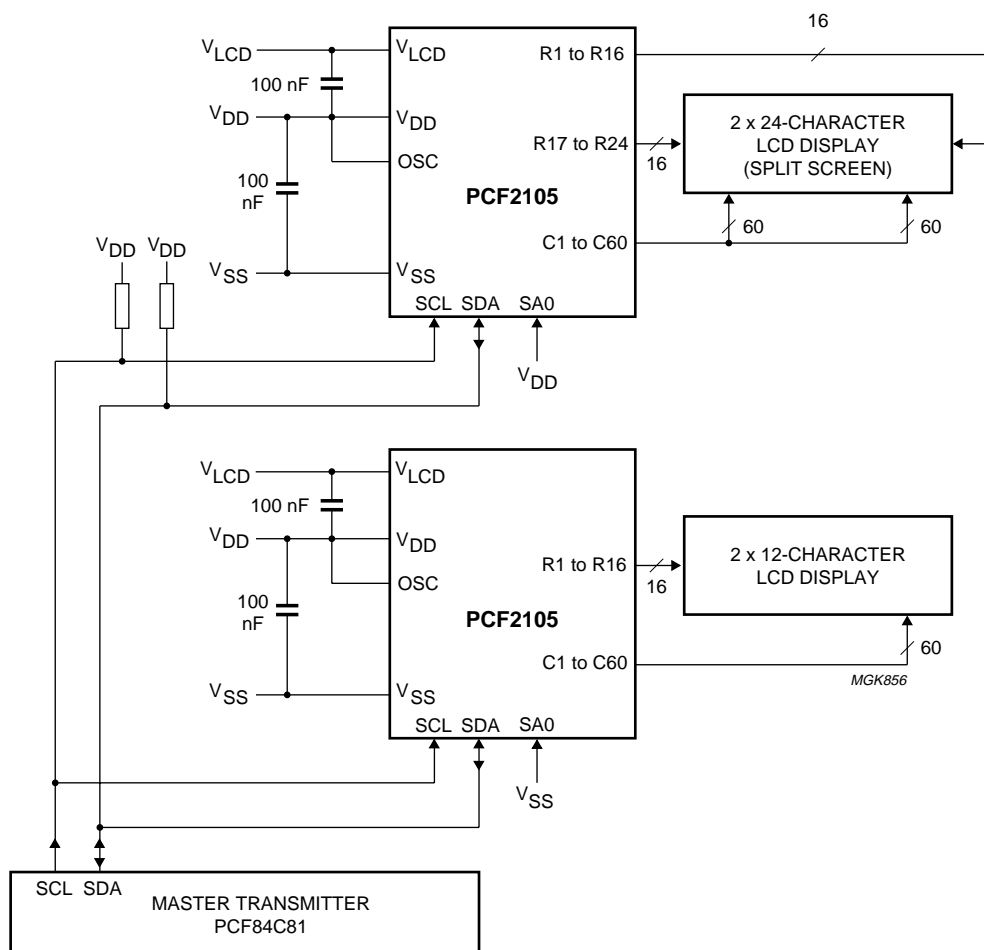

Fig.29 Application using I<sup>2</sup>C-bus interface.

---

**LCD controller/driver****PCF2105**

---

**17.1 4-bit operation, 2 × 12 display using internal reset**

The program must set functions prior to 4-bit operation. Table 6 shows an example. When power is turned on, 8-bit operation is automatically selected and the PCF2105 attempts to perform the first write as an 8-bit operation. Since nothing is connected to DB3 to DB0, a rewrite is then required. However, since one operation is completed in two accesses of 4-bit operation, a rewrite is required to set the functions (see Table 6 step 3).

Thus, DB7 to DB4 of the 'function set' are written twice.

**17.2 8-bit operation, 2 × 12 display using internal reset**

Table 7 shows an example of a 1-line display in 8-bit operation. The PCF2105 functions must be set by the 'function set' instruction prior to display. Since the DDRAM can store data for 80 characters, the RAM can be used for advertising displays when combined with display shift operation. Since the display shift operation changes the display position only DDRAM contents remain unchanged. Display data entered first can be displayed when the 'return home' instruction is performed.

**17.3 8-bit operation, 2 × 24 display**

For a 2-line display, the cursor automatically moves from the first to the second line after the 40th digit of the first line has been written. Thus, if there are only 8 characters in the first line, the DDRAM address must be set after the 8th character is completed (see Table 8). It should be noted that both lines of the display are always shifted together, data does not shift from one line to the other.

**17.4 I<sup>2</sup>C-bus operation, 2 × 12 display**

A control byte is required with most instructions (see Table 9).

**17.5 Initializing by instruction**

If the power supply conditions for correctly operating the internal reset circuit are not met, the PCF2105 must be initialized by instruction. Tables 10 and 11 show how this may be performed for 8-bit and 4-bit operation.

LCD controller/driver

PCF2105

**Table 6** Example of 4-bit operation; 1-line display; using internal reset

STEP	INSTRUCTION	DISPLAY	OPERATION
1	power supply on (PCF2105 is initialized by the internal reset circuit)		initialized; no display appears
2	function set RS R/W DB7 DB6 DB5 DB4 0 0 0 0 1 0		sets to 4-bit operation; in this instance operation is handled as 8-bits by initialization and only this instruction completes with one write
3	function set RS R/W DB7 DB6 DB5 DB4 0 0 0 0 1 0 0 0 0 0 0 0		sets to 4-bit operation; selects 2 × 12 display
			4-bit operation starts from this point and resetting is needed
4	display control RS R/W DB7 DB6 DB5 DB4 0 0 0 0 0 0 0 0 1 1 1 0	–	turns display and cursor on
			entire display is blank after initialization
5	entry mode set RS R/W DB7 DB6 DB5 DB4 0 0 0 0 0 0 0 0 0 1 1 0	–	sets mode to increment the address by 1 and to shift the cursor to the right at the time of write to the DDRAM or CGRAM
			display is not shifted
6	write data to CGRAM or DDRAM RS R/W DB7 DB6 DB5 DB4 1 0 1 1 0 1 1 0 0 1 1 0	P_	writes 'P'; the DDRAM has already been selected by initialization at power-on
			the cursor is incremented by 1 and shifted to the right

## LCD controller/driver

## PCF2105

**Table 7** Example of 8-bit operation; 1-line display; using internal reset (character set 'M')

STEP	INSTRUCTION	DISPLAY	OPERATION
1	power supply on (PCF2105 is initialized by the internal reset function)		initialized; no display appears
2	function set RS R/W DB7 DB6 DB5 DB4 DB3 DB2 DB1 DB0 0 0 0 0 1 1 0 0 0 0		sets to 8-bit operation; selects 2 × 12 display
3	display control RS R/W DB7 DB6 DB5 DB4 DB3 DB2 DB1 DB0 0 0 0 0 0 0 1 1 1 0	–	turns display and cursor on; entire display is blank after initialization
4	entry mode set RS R/W DB7 DB6 DB5 DB4 DB3 DB2 DB1 DB0 0 0 0 0 0 0 0 1 1 0	–	sets mode to increment the address by 1 and to shift the cursor to the right at the time of the write to the DDRAM or CGRAM; display is not shifted
5	write data to CGRAM or DDRAM RS R/W DB7 DB6 DB5 DB4 DB3 DB2 DB1 DB0 1 0 1 1 0 1 0 0 0 0	P_	writes 'P'; the DDRAM has already been selected by initialization at power-on; the cursor is incremented by 1 and shifted to the right
6	write data to CGRAM or DDRAM RS R/W DB7 DB6 DB5 DB4 DB3 DB2 DB1 DB0 1 0 1 1 0 0 1 0 0 0	PH_	writes 'H'
7			
8	write data to CGRAM or DDRAM RS R/W DB7 DB6 DB5 DB4 DB3 DB2 DB1 DB0 1 0 1 1 0 1 0 0 1 1	PHILIPS_	writes 'S'
9	entry mode set RS R/W DB7 DB6 DB5 DB4 DB3 DB2 DB1 DB0 0 0 0 0 0 0 0 1 1 1	PHILIPS_	sets mode for display shift at the time of write
10	write data to CGRAM or DDRAM RS R/W DB7 DB6 DB5 DB4 DB3 DB2 DB1 DB0 1 0 0 0 1 0 0 0 0 0	HILIPS_	writes space
11	write data to CGRAM or DDRAM RS R/W DB7 DB6 DB5 DB4 DB3 DB2 DB1 DB0 1 0 1 1 0 0 1 1 0 1	ILIPS M_	writes 'M'

## LCD controller/driver

## PCF2105

STEP	INSTRUCTION	DISPLAY	OPERATION
12			
13	write data to CGRAM or DDRAM RS R $\bar{W}$ DB7 DB6 DB5 DB4 DB3 DB2 DB1 DB0 1 0 1 1 0 0 1 1 1 1	<b>MICROKO<sub>-</sub></b>	writes 'O'
14	cursor or display shift RS R $\bar{W}$ DB7 DB6 DB5 DB4 DB3 DB2 DB1 DB0 0 0 0 0 0 1 0 0 0 0	<b>MICROKO</b>	shifts only the cursor position to the left
15	cursor or display shift RS R $\bar{W}$ DB7 DB6 DB5 DB4 DB3 DB2 DB1 DB0 0 0 0 0 0 1 0 0 0 0	<b>MICROKO</b>	shifts only the cursor position to the left
16	write data to CGRAM or DDRAM RS R $\bar{W}$ DB7 DB6 DB5 DB4 DB3 DB2 DB1 DB0 1 0 0 1 0 0 0 0 1 1	<b>ICROCO</b>	writes 'C' (correction); the display moves to the left
17	cursor or display shift RS R $\bar{W}$ DB7 DB6 DB5 DB4 DB3 DB2 DB1 DB0 0 0 0 0 0 1 1 1 0 0	<b>MICROCO</b>	shifts the display and cursor to the right
18	cursor or display shift RS R $\bar{W}$ DB7 DB6 DB5 DB4 DB3 DB2 DB1 DB0 0 0 0 0 0 1 0 1 0 0	<b>MICROCO<sub>-</sub></b>	shifts only the cursor to the right
19	write data to CGRAM or DDRAM RS R $\bar{W}$ DB7 DB6 DB5 DB4 DB3 DB2 DB1 DB0 1 0 1 1 0 0 1 1 0 1	<b>ICROCOM<sub>-</sub></b>	writes 'M'
20			
21	return home RS R $\bar{W}$ DB7 DB6 DB5 DB4 DB3 DB2 DB1 DB0 0 0 0 0 0 0 0 0 1 0	<b>PHILIPS M</b>	returns both display and cursor to the original position (address 0)

## LCD controller/driver

## PCF2105

**Table 8** Example of 8-bit operation; 2-line display; using internal reset

STEP	INSTRUCTION	DISPLAY	OPERATION
1	power supply on (PCF2105 is initialized by the internal reset function)		initialized; no display appears
2	function set RS R/W DB7 DB6 DB5 DB4 DB3 DB2 DB1 DB0 0 0 0 0 1 1 1 0 0 0		sets to 8-bit operation; selects 2 × 24 display
3	display control RS R/W DB7 DB6 DB5 DB4 DB3 DB2 DB1 DB0 0 0 0 0 0 0 1 1 1 0		turns display and cursor on; entire display is blank after initialization
4	entry mode set RS R/W DB7 DB6 DB5 DB4 DB3 DB2 DB1 DB0 0 0 0 0 0 0 0 1 1 0	—	sets mode to increment the address by 1 and to shift the cursor to the right at the time of write to the CGRAM or DDRAM; display is not shifted
5	write data to CGRAM or DDRAM RS R/W DB7 DB6 DB5 DB4 DB3 DB2 DB1 DB0 1 0 1 1 0 1 0 0 0 0	P_	writes 'P'; the DDRAM has already been selected by initialization at power-on; the cursor is incremented by 1 and shifted to the right
6		—	
7	write data to CGRAM or DDRAM RS R/W DB7 DB6 DB5 DB4 DB3 DB2 DB1 DB0 1 0 1 1 0 1 0 0 1 1	PHILIPS_	writes 'S'
8	set DDRAM address RS R/W DB7 DB6 DB5 DB4 DB3 DB2 DB1 DB0 0 0 1 1 0 0 0 0 0 0	PHILIPS —	sets DDRAM address to position the cursor at the head of the 2nd line
9	write data to CGRAM or DDRAM RS R/W DB7 DB6 DB5 DB4 DB3 DB2 DB1 DB0 1 0 1 1 0 0 1 1 0 1	PHILIPS M_	writes 'M'
10		—	
11	write data to CGRAM or DDRAM RS R/W DB7 DB6 DB5 DB4 DB3 DB2 DB1 DB0 1 0 1 1 0 0 1 1 1 1	PHILIPS MICROCO_	writes 'O'

## LCD controller/driver

## PCF2105

STEP	INSTRUCTION	DISPLAY	OPERATION
12	write data to CGRAM or DDRAM	<b>PHILIPS</b>	sets mode for display shift at the time of write
	RS R $\bar{W}$ DB7 DB6 DB5 DB4 DB3 DB2 DB1 DB0 0 0 0 0 0 0 0 1 1 1	<b>MICROCO_</b>	
13	write data to CGRAM or DDRAM	<b>HILIPS</b>	writes 'M'; display is shifted to the left; the first and second lines shift together
	RS R $\bar{W}$ DB7 DB6 DB5 DB4 DB3 DB2 DB1 DB0 1 0 1 1 0 0 1 1 0 1	<b>ICROCOM_</b>	
14		   	
15	return home	<b>PHILIPS</b>	returns both display and cursor to the original position (address 0)
	RS R $\bar{W}$ DB7 DB6 DB5 DB4 DB3 DB2 DB1 DB0 0 0 0 0 0 0 0 0 1 0	<b>MICROCOM</b>	

**Table 9** Example of I<sup>2</sup>C-bus operation; 1-line display; using internal reset (assuming SA0 = V<sub>SS</sub>); note 1

STEP	INSTRUCTION	DISPLAY	OPERATION
1	I <sup>2</sup> C-bus start		initialized; no display appears
2	slave address for write		during the acknowledge cycle SDA will be pulled-down by the PCF2105
	SA6 SA5 SA4 SA3 SA2 SA1 SA0 R $\bar{W}$ Ack 0 1 1 1 0 1 0 0 1		
3	send a control byte for function set		control byte sets RS and R $\bar{W}$ for following data bytes
	Co RS R $\bar{W}$ Ack 0 0 0 1		
4	function set		selects 1-line display; SCL pulse during acknowledge cycle starts execution of instruction
	DB7 DB6 DB5 DB4 DB3 DB2 DB1 DB0 Ack 0 0 1 X 0 0 0 0 1		
5	display control	–	turns display and cursor on; entire display shows character hexadecimal 20 (blank in ASCII-like character sets)
	DB7 DB6 DB5 DB4 DB3 DB2 DB1 DB0 Ack 0 0 0 0 1 1 1 0 1		
6	entry mode set	–	sets mode to increment the address by 1 and to shift the cursor to the right at the time of write to the DDRAM or CGRAM; display is not shifted
	DB7 DB6 DB5 DB4 DB3 DB2 DB1 DB0 Ack 0 0 0 0 0 1 1 0 1		

## LCD controller/driver

## PCF2105

STEP	INSTRUCTION	DISPLAY	OPERATION
7	I <sup>2</sup> C-bus start	–	for writing data to DDRAM, RS must be set to logic 1; therefore a control byte is needed
8	slave address for write SA6 SA5 SA4 SA3 SA2 SA1 SA0 R/W Ack 0 1 1 1 0 1 0 0 1	–	
9	send a control byte for write data Co RS R/W Ack 0 1 0 1	–	
10	write data to DDRAM DB7 DB6 DB5 DB4 DB3 DB2 DB1 DB0 Ack 1 1 0 1 0 0 0 0 1	P_	writes 'P'; the DDRAM has been selected at power-up; the cursor is incremented by 1 and shifted to the right
11	write data to DDRAM DB7 DB6 DB5 DB4 DB3 DB2 DB1 DB0 Ack 1 1 0 0 1 0 0 0 1	PH_	writes 'H'
12 to 15		     	
16	write data to DDRAM DB7 DB6 DB5 DB4 DB3 DB2 DB1 DB0 Ack 1 1 0 1 0 0 1 1 1	PHILIPS_	writes 'S'
17	(optional I <sup>2</sup> C-bus stop) I <sup>2</sup> C-bus start + slave address for write (as step 8)	PHILIPS_	
18	control byte Co RS R/W Ack 1 0 0 1	PHILIPS_	
19	return home DB7 DB6 DB5 DB4 DB3 DB2 DB1 DB0 Ack 0 0 0 0 0 0 1 0 1	PHILIPS	sets DDRAM address 0 in AC; also returns shifted display to original position; DDRAM contents unchanged; this instruction does not update the DR
20	control byte for read Co RS R/W Ack 0 1 1 1	PHILIPS	DDRAM content will be read from following instructions; the R/W has to be set to logic 1 while still in I <sup>2</sup> C-bus write mode
21	I <sup>2</sup> C-bus start	PHILIPS	



## LCD controller/driver

PCF2105

STEP	INSTRUCTION	DISPLAY	OPERATION
22	slave address for read SA6 SA5 SA4 SA3 SA2 SA1 SA0 R/W Ack 0 1 1 1 0 1 0 1 1	<b>PHILIPS</b>	during the acknowledge cycle the content of the DR is loaded into the internal I <sup>2</sup> C-bus interface and to be shifted out; in the previous instruction neither a 'set address' nor a 'read data' has been performed; therefore the content of the DR was unknown
23	read data: 8 × SCL + master acknowledge; note 2 DB7 DB6 DB5 DB4 DB3 DB2 DB1 DB0 Ack X X X X X X X X 1	<b>PHILIPS</b>	8 × SCL; content loaded into interface during previous acknowledge cycle and shifted out over SDA; MSB is DB7; during master acknowledge content of DDRAM address 01 is loaded into the I <sup>2</sup> C-bus interface
24	read data: 8 × SCL + master acknowledge; note 2 DB7 DB6 DB5 DB4 DB3 DB2 DB1 DB0 Ack 0 1 0 0 1 0 0 0 0	<b>PHILIPS</b>	8 × SCL; code of letter 'H' is read first; during master acknowledge code of letter 'I' is loaded into the I <sup>2</sup> C-bus interface
25	read data: 8 × SCL + no master acknowledge; note 2 DB7 DB6 DB5 DB4 DB3 DB2 DB1 DB0 Ack 0 1 0 0 1 0 0 1 1	<b>PHILIPS</b>	no master acknowledge; after the content of the I <sup>2</sup> C-bus interface register is shifted out no internal action is performed; no new data is loaded to the interface register; DR is not updated; AC is not incremented and cursor is not shifted
26	I <sup>2</sup> C-bus stop	<b>PHILIPS</b>	

**Notes**

1. X = don't care.
2. SDA is left at high-impedance by the microcontroller during the READ acknowledge.

LCD controller/driver

PCF2105

**Table 10** Initialization by instruction; 8-bit interface (note 1)

STEP										DESCRIPTION
Power-on or unknown state										
Wait 2 ms after V <sub>DD</sub> rises above V <sub>POR</sub>										
										BF cannot be checked before this instruction; function set (interface is 8-bits long)
RS	R/W	DB7	DB6	DB5	DB4	DB3	DB2	DB1	DB0	
0	0	0	0	1	1	X	X	X	X	
Wait 2 ms										
RS	R/W	DB7	DB6	DB5	DB4	DB3	DB2	DB1	DB0	BF cannot be checked before this instruction; function set (interface is 8-bits long)
0	0	0	0	1	1	X	X	X	X	
Wait more than 40 μs										
RS	R/W	DB7	DB6	DB5	DB4	DB3	DB2	DB1	DB0	
0	0	0	0	1	1	X	X	X	X	
										BF can be checked after the following instructions; when BF is not checked, the waiting time between instructions is the specified instruction time (see Table 3)
RS	R/W	DB7	DB6	DB5	DB4	DB3	DB2	DB1	DB0	
0	0	0	0	1	1	N	M	X	0	function set (interface is 8-bits long); specify the number of display lines
RS	R/W	DB7	DB6	DB5	DB4	DB3	DB2	DB1	DB0	
0	0	0	0	0	0	1	0	0	0	
RS	R/W	DB7	DB6	DB5	DB4	DB3	DB2	DB1	DB0	clear display
0	0	0	0	0	0	0	0	0	1	
RS	R/W	DB7	DB6	DB5	DB4	DB3	DB2	DB1	DB0	entry mode set
0	0	0	0	0	0	0	1	I/D	S	
Initialization ends										

**Note**

1. X = don't care.

LCD controller/driver

PCF2105

**Table 11** Initialization by instruction; 4-bit interface; not applicable for I<sup>2</sup>C-bus operation

STEP							DESCRIPTION
Power-on or unknown state							
Wait 2 ms after V <sub>DD</sub> rises above V <sub>POR</sub>							
							BF cannot be checked before this instruction; function set (interface is 8-bits long)
RS	R/W	DB7	DB6	DB5	DB4		
0	0	0	0	1	1		
							BF cannot be checked before this instruction; function set (interface is 8-bits long)
Wait 2 ms							
RS	R/W	DB7	DB6	DB5	DB4		
0	0	0	0	1	1		
							BF cannot be checked before this instruction; function set (interface is 8-bits long)
Wait 40 μs							
RS	R/W	DB7	DB6	DB5	DB4		
0	0	0	0	1	1		
							BF can be checked after the following instructions; when BF is not checked, the waiting time between instructions is the specified instruction time (see Table 3)
RS	R/W	DB7	DB6	DB5	DB4		
0	0	0	0	1	0		
RS	R/W	DB7	DB6	DB5	DB4		
0	0	0	0	1	0		
RS	R/W	DB7	DB6	DB5	DB4		
0	0	N	M	0	0		
RS	R/W	DB7	DB6	DB5	DB4		
0	0	0	0	0	0		
0	0	1	0	0	0		
RS	R/W	DB7	DB6	DB5	DB4		
0	0	0	0	0	0		
0	0	0	1	I/D	S		
							Initialization ends
Initialization ends							

LCD controller/driver

PCF2105

18 BONDING PAD LOCATIONS

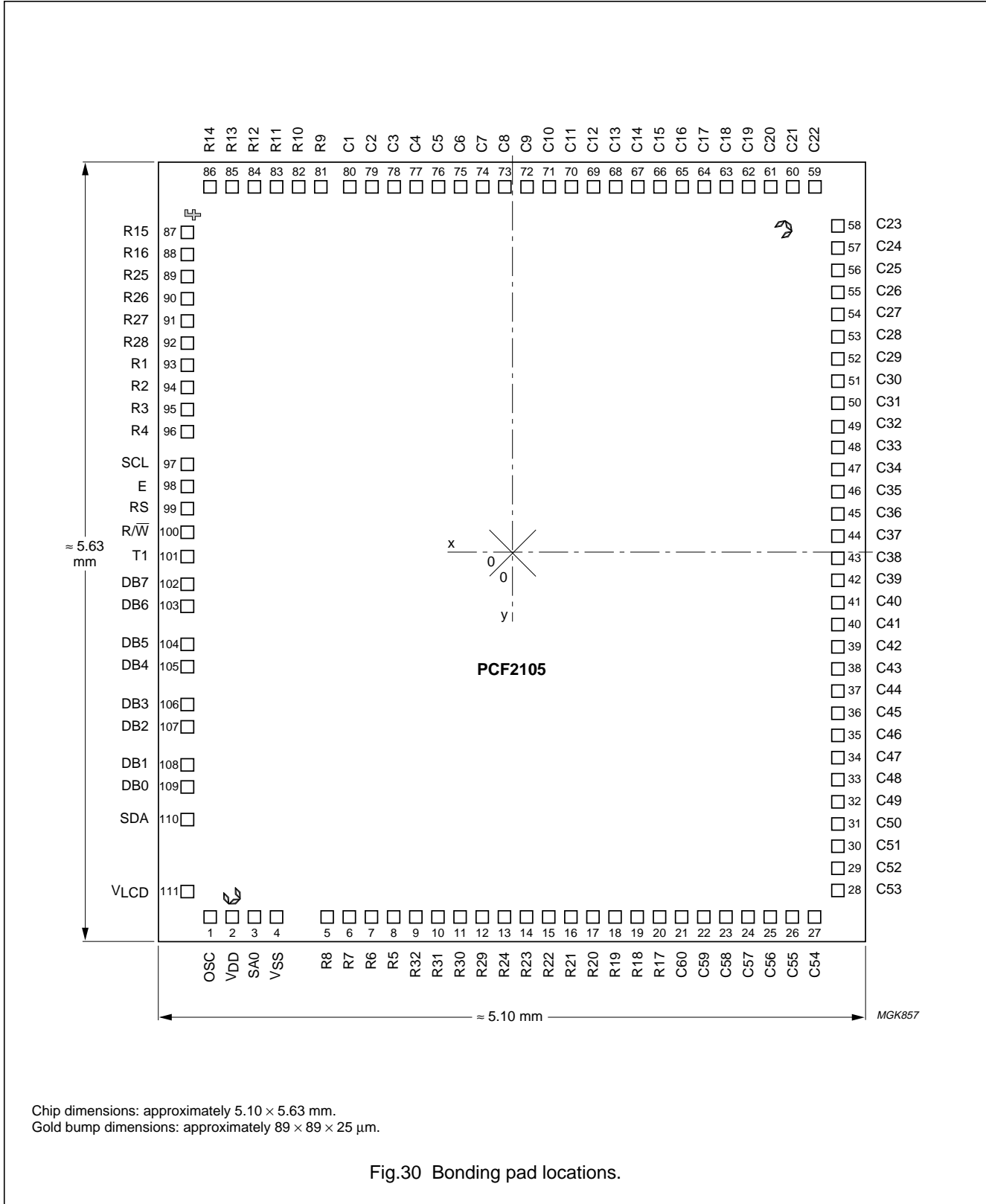

Fig.30 Bonding pad locations.

## LCD controller/driver

## PCF2105

**Table 12** Bonding pad locations (dimensions in  $\mu\text{m}$ ).

All x/y coordinates are referenced to centre of chip,  
see Fig.30.

SYMBOL	PAD	x	y
OSC	1	-2184.5	-2637
V <sub>DD</sub>	2	-2024.5	-2637
SA0	3	-1864.5	-2637
V <sub>SS</sub>	4	-1704.5	-2637
R8	5	-1339	-2637
R7	6	-1179	-2637
R6	7	-1019	-2637
R5	8	-859	-2637
R32	9	-699	-2637
R31	10	-539	-2637
R30	11	-379	-2637
R29	12	-219	-2637
R24	13	-59	-2637
R23	14	101	-2637
R22	15	261	-2637
R21	16	421	-2637
R20	17	581	-2637
R19	18	741	-2637
R18	19	901	-2637
R17	20	1061	-2637
C60	21	1221	-2637
C59	22	1381	-2637
C58	23	1541	-2637
C57	24	1701	-2637
C56	25	1861	-2637
C55	26	2021	-2637
C54	27	2181	-2637
C53	28	2350	-2445
C52	29	2350	-2285
C51	30	2350	-2125
C50	31	2350	-1965
C49	32	2350	-1805
C48	33	2350	-1645
C47	34	2350	-1485
C46	35	2350	-1325
C45	36	2350	-1165
C44	37	2350	-1005
C43	38	2350	-845

SYMBOL	PAD	x	y
C42	39	2350	-685
C41	40	2350	-525
C40	41	2350	-365
C39	42	2350	-205
C38	43	2350	-45
C37	44	2350	115
C36	45	2350	275
C35	46	2350	435
C34	47	2350	595
C33	48	2350	755
C32	49	2350	915
C31	50	2350	1075
C30	51	2350	1235
C29	52	2350	1395
C28	53	2350	1555
C27	54	2350	1715
C26	55	2350	1875
C25	56	2350	2035
C24	57	2350	2195
C23	58	2350	2355
C22	59	2185	2637.5
C21	60	2025	2637.5
C20	61	1865	2637.5
C19	62	1705	2637.5
C18	63	1545	2637.5
C17	64	1385	2637.5
C16	65	1225	2637.5
C15	66	1065	2637.5
C14	67	905	2637.5
C13	68	745	2637.5
C12	69	585	2637.5
C11	70	425	2637.5
C10	71	265	2637.5
C9	72	105	2637.5
C8	73	-55	2637.5
C7	74	-215	2637.5
C6	75	-375	2637.5
C5	76	-535	2637.5

## LCD controller/driver

## PCF2105

SYMBOL	PAD	x	y
C4	77	-695	2637.5
C3	78	-855	2637.5
C2	79	-1015	2637.5
C1	80	-1175	2637.5
R9	81	-1385	2637.5
R10	82	-1545	2637.5
R11	83	-1705	2637.5
R12	84	-1865	2637.5
R13	85	-2025	2637.5
R14	86	-2185	2637.5
R15	87	-2349	2308
R16	88	-2349	2148
R25	89	-2349	1988
R26	90	-2349	1828
R27	91	-2349	1668
R28	92	-2349	1508
R1	93	-2349	1348
R2	94	-2349	1188
R3	95	-2349	1028
R4	96	-2349	868
SCL	97	-2349	632
E	98	-2349	472
RS	99	-2349	312
R $\bar{W}$	100	-2349	142
T1	101	-2349	-34
DB7	102	-2349	-233
DB6	103	-2349	-393
DB5	104	-2349	-668
DB4	105	-2349	-828
DB3	106	-2349	-1103
DB2	107	-2349	-1263
DB1	108	-2349	-1538
DB0	109	-2349	-1698
SDA	110	-2349	-1933
V <sub>LCD</sub>	111	-2349	-2453
RECPAT 'F'	-	-2327.5	2427.5
RECPAT 'C'	-	-2027.5	-2512.5
RECPAT 'C'	-	1982.5	2297.5

## LCD controller/driver

## PCF2105

**19 DEFINITIONS**

<b>Data sheet status</b>	
Objective specification	This data sheet contains target or goal specifications for product development.
Preliminary specification	This data sheet contains preliminary data; supplementary data may be published later.
Product specification	This data sheet contains final product specifications.
<b>Limiting values</b>	
Limiting values given are in accordance with the Absolute Maximum Rating System (IEC 134). Stress above one or more of the limiting values may cause permanent damage to the device. These are stress ratings only and operation of the device at these or at any other conditions above those given in the Characteristics sections of the specification is not implied. Exposure to limiting values for extended periods may affect device reliability.	
<b>Application information</b>	
Where application information is given, it is advisory and does not form part of the specification.	

**20 LIFE SUPPORT APPLICATIONS**

These products are not designed for use in life support appliances, devices, or systems where malfunction of these products can reasonably be expected to result in personal injury. Philips customers using or selling these products for use in such applications do so at their own risk and agree to fully indemnify Philips for any damages resulting from such improper use or sale.

**21 PURCHASE OF PHILIPS I<sup>2</sup>C COMPONENTS**

Purchase of Philips I<sup>2</sup>C components conveys a license under the Philips' I<sup>2</sup>C patent to use the components in the I<sup>2</sup>C system provided the system conforms to the I<sup>2</sup>C specification defined by Philips. This specification can be ordered using the code 9398 393 40011.

# Philips Semiconductors – a worldwide company

**Argentina:** see South America

**Australia:** 34 Waterloo Road, NORTH RYDE, NSW 2113,  
Tel. +61 2 9805 4455, Fax. +61 2 9805 4466

**Austria:** Computerstr. 6, A-1101 WIEN, P.O. Box 213, Tel. +43 160 1010,  
Fax. +43 160 101 1210

**Belarus:** Hotel Minsk Business Center, Bld. 3, r. 1211, Volodarski Str. 6,  
220050 MINSK, Tel. +375 172 200 733, Fax. +375 172 200 773

**Belgium:** see The Netherlands

**Brazil:** see South America

**Bulgaria:** Philips Bulgaria Ltd., Energoproject, 15th floor,  
51 James Bourchier Blvd., 1407 SOFIA,  
Tel. +359 2 689 211, Fax. +359 2 689 102

**Canada:** PHILIPS SEMICONDUCTORS/COMPONENTS,  
Tel. +1 800 234 7381

**China/Hong Kong:** 501 Hong Kong Industrial Technology Centre,  
72 Tat Chee Avenue, Kowloon Tong, HONG KONG,  
Tel. +852 2319 7888, Fax. +852 2319 7700

**Colombia:** see South America

**Czech Republic:** see Austria

**Denmark:** Prags Boulevard 80, PB 1919, DK-2300 COPENHAGEN S,  
Tel. +45 32 88 2636, Fax. +45 31 57 0044

**Finland:** Sinikalliontie 3, FIN-02630 ESPOO,  
Tel. +358 9 615800, Fax. +358 9 61580920

**France:** 51 Rue Carnot, BP317, 92156 SURESNES Cedex,  
Tel. +33 1 40 99 6161, Fax. +33 1 40 99 6427

**Germany:** Hammerbrookstraße 69, D-20097 HAMBURG,  
Tel. +49 40 23 53 60, Fax. +49 40 23 536 300

**Greece:** No. 15, 25th March Street, GR 17778 TAVROS/ATHENS,  
Tel. +30 1 4894 339/239, Fax. +30 1 4814 240

**Hungary:** see Austria

**India:** Philips INDIA Ltd, Band Box Building, 2nd floor,  
254-D, Dr. Annie Besant Road, Worli, MUMBAI 400 025,  
Tel. +91 22 493 8541, Fax. +91 22 493 0966

**Indonesia:** PT Philips Development Corporation, Semiconductors Division,  
Gedung Philips, Jl. Buncit Raya Kav.99-100, JAKARTA 12510,  
Tel. +62 21 794 0040 ext. 2501, Fax. +62 21 794 0080

**Ireland:** Newstead, Clonskeagh, DUBLIN 14,  
Tel. +353 1 7640 000, Fax. +353 1 7640 200

**Israel:** RAPAC Electronics, 7 Kehilat Saloniki St, PO Box 18053,  
TEL AVIV 61180, Tel. +972 3 645 0444, Fax. +972 3 649 1007

**Italy:** PHILIPS SEMICONDUCTORS, Piazza IV Novembre 3,  
20124 MILANO, Tel. +39 2 6752 2531, Fax. +39 2 6752 2557

**Japan:** Philips Bldg 13-37, Kohnan 2-chome, Minato-ku,  
TOKYO 108-8507, Tel. +81 3 3740 5130, Fax. +81 3 3740 5077

**Korea:** Philips House, 260-199 Itaewon-dong, Yongsan-ku, SEOUL,  
Tel. +82 2 709 1412, Fax. +82 2 709 1415

**Malaysia:** No. 76 Jalan Universiti, 46200 PETALING JAYA, SELANGOR,  
Tel. +60 3 750 5214, Fax. +60 3 757 4880

**Mexico:** 5900 Gateway East, Suite 200, EL PASO, TEXAS 79905,  
Tel. +9-5 800 234 7381

**Middle East:** see Italy

**Netherlands:** Postbus 90050, 5600 PB EINDHOVEN, Bldg. VB,  
Tel. +31 40 27 82785, Fax. +31 40 27 88399

**New Zealand:** 2 Wagener Place, C.P.O. Box 1041, AUCKLAND,  
Tel. +64 9 849 4160, Fax. +64 9 849 7811

**Norway:** Box 1, Manglerud 0612, OSLO,  
Tel. +47 22 74 8000, Fax. +47 22 74 8341

**Pakistan:** see Singapore

**Philippines:** Philips Semiconductors Philippines Inc.,  
106 Valero St. Salcedo Village, P.O. Box 2108 MCC, MAKATI,  
Metro MANILA, Tel. +63 2 816 6380, Fax. +63 2 817 3474

**Poland:** Ul. Lukiska 10, PL 04-123 WARSZAWA,  
Tel. +48 22 612 2831, Fax. +48 22 612 2327

**Portugal:** see Spain

**Romania:** see Italy

**Russia:** Philips Russia, Ul. Usatcheva 35A, 119048 MOSCOW,  
Tel. +7 095 755 6918, Fax. +7 095 755 6919

**Singapore:** Lorong 1, Toa Payoh, SINGAPORE 319762,  
Tel. +65 350 2538, Fax. +65 251 6500

**Slovakia:** see Austria

**Slovenia:** see Italy

**South Africa:** S.A. PHILIPS Pty Ltd., 195-215 Main Road Martindale,  
2092 JOHANNESBURG, P.O. Box 7430 Johannesburg 2000,  
Tel. +27 11 470 5911, Fax. +27 11 470 5494

**South America:** Al. Vicente Pinzon, 173, 6th floor,  
04547-130 SÃO PAULO, SP, Brazil,  
Tel. +55 11 821 2333, Fax. +55 11 821 2382

**Spain:** Balmes 22, 08007 BARCELONA,  
Tel. +34 93 301 6312, Fax. +34 93 301 4107

**Sweden:** Kottbygatan 7, Akalla, S-16485 STOCKHOLM,  
Tel. +46 8 5985 2000, Fax. +46 8 5985 2745

**Switzerland:** Allmendstrasse 140, CH-8027 ZÜRICH,  
Tel. +41 1 488 2741 Fax. +41 1 488 3263

**Taiwan:** Philips Semiconductors, 6F, No. 96, Chien Kuo N. Rd., Sec. 1,  
TAIPEI, Taiwan Tel. +886 2 2134 2865, Fax. +886 2 2134 2874

**Thailand:** PHILIPS ELECTRONICS (THAILAND) Ltd.,  
209/2 Sanpavuth-Bangna Road Prakanong, BANGKOK 10260,  
Tel. +66 2 745 4090, Fax. +66 2 398 0793

**Turkey:** Talatpasa Cad. No. 5, 80640 GÜLTEPE/ISTANBUL,  
Tel. +90 212 279 2770, Fax. +90 212 282 6707

**Ukraine:** PHILIPS UKRAINE, 4 Patrice Lumumba str., Building B, Floor 7,  
252042 KIEV, Tel. +380 44 264 2776, Fax. +380 44 268 0461

**United Kingdom:** Philips Semiconductors Ltd., 276 Bath Road, Hayes,  
MIDDLESEX UB3 5BX, Tel. +44 181 730 5000, Fax. +44 181 754 8421

**United States:** 811 East Arques Avenue, SUNNYVALE, CA 94088-3409,  
Tel. +1 800 234 7381

**Uruguay:** see South America

**Vietnam:** see Singapore

**Yugoslavia:** PHILIPS, Trg N. Pasica 5/v, 11000 BEOGRAD,  
Tel. +381 11 625 344, Fax. +381 11 635 777

**For all other countries apply to:** Philips Semiconductors,  
International Marketing & Sales Communications, Building BE-p, P.O. Box 218,  
5600 MD EINDHOVEN, The Netherlands, Fax. +31 40 27 24825

**Internet:** <http://www.semiconductors.philips.com>

© Philips Electronics N.V. 1998

SCA60

All rights are reserved. Reproduction in whole or in part is prohibited without the prior written consent of the copyright owner.

The information presented in this document does not form part of any quotation or contract, is believed to be accurate and reliable and may be changed without notice. No liability will be accepted by the publisher for any consequence of its use. Publication thereof does not convey nor imply any license under patent- or other industrial or intellectual property rights.

Printed in The Netherlands

415106/1200/02/pp48

Date of release: 1998 Jul 30

Document order number: 9397 750 04198

*Let's make things better.*

**Philips**  
Semiconductors



**PHILIPS**