

16-Bit, 2-Port Bus Switch

Product Features

- Near-zero propagation delay
- 5Ω switches connect inputs to outputs
- Direct bus connection when switches are ON
- Ultra-low quiescent power (0.2μA typical)
 - Ideally suited for notebook applications
- Pin compatible with 74 series 16245
- Industrial operating temperature: -40°C to +85°C
- Packages available:
 - 48-pin 240 mil wide thin plastic TSSOP (A)
 - 48-pin 150 mil wide plastic BQSOP (B)
 - 48-pin 300 mil wide plastic SSOP (V)

Product Description

Pericom Semiconductor’s PI5C series of logic circuits are produced using the Company’s advanced 0.6 micron CMOS technology.

The PI5C16245 and PI5C162245 are 16-bit, 2-port bus switches that are pin compatible with the 74 series 16245 16-bit transceiver. Two enable signals (\overline{nBE}) turn the switches on, similar to the enable signals of the 16245. The bus switch creates no additional propagational delay or additional ground bounce noise.

The PI5C162245 device has a built-in 25-ohm series resistor to reduce reflection noise, thus eliminating the need for an external terminating resistor.

Logic Block Diagram

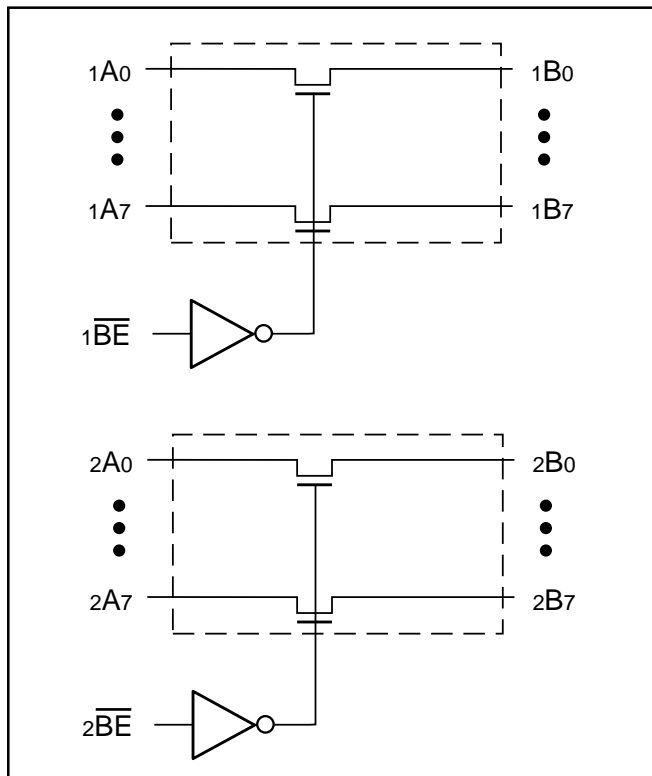

Truth Table⁽¹⁾

Function	\overline{nBE}	nA0-7
Disconnect	H	Hi-Z
Connect	L	nB0-7

Note: 1. H = High Voltage Level
L = Low Voltage Level
Hi-Z = High Impedance

Product Pin Configuration

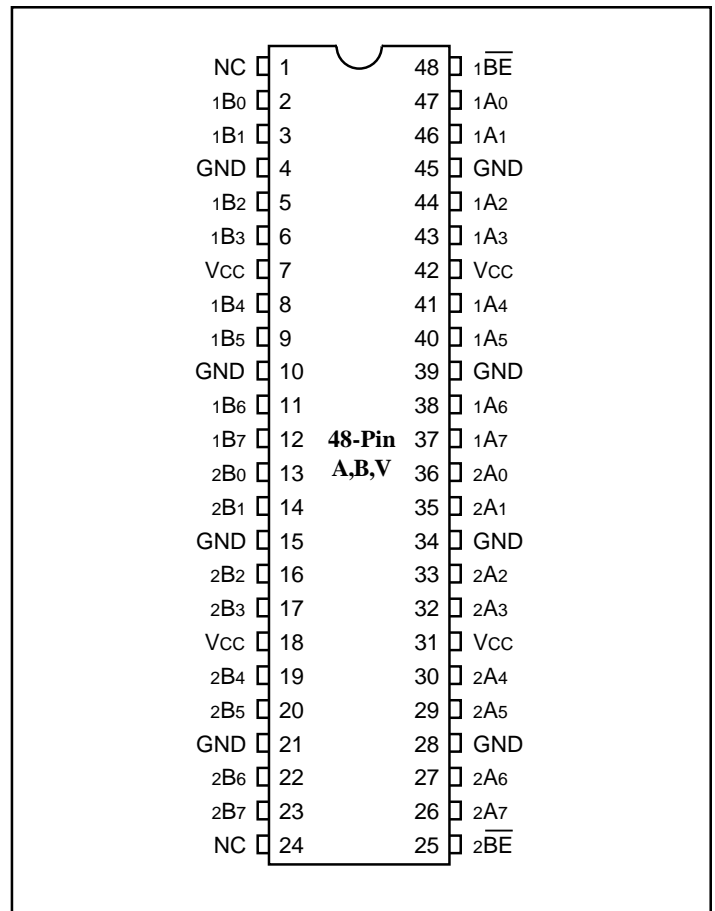

Product Pin Description

Pin Name	I/O	Description
\overline{nBE}	I	Bus Enable Input (Active LOW)
nA0-nA7	I/O	Bus A
nB0-nB7	I/O	Bus B

Maximum Ratings

(Above which the useful life may be impaired. For user guidelines, not tested.)

Storage Temperature	-65°C to +150°C
Ambient Temperature with Power Applied	-40°C to +85°C
Supply Voltage to Ground Potential (Inputs & V _{CC} Only)	-0.5V to +7.0V
Supply Voltage to Ground Potential (Outputs & D/O Only)	-0.5V to +7.0V
DC Input Voltage	-0.5V to +7.0V
DC Output Current	120mA
Power Dissipation	0.5W

Note:

Stresses greater than those listed under MAXIMUM RATINGS may cause permanent damage to the device. This is a stress rating only and functional operation of the device at these or any other conditions above those indicated in the operational sections of this specification is not implied. Exposure to absolute maximum rating conditions for extended periods may affect reliability.

DC Electrical Characteristics (Over Operating Range, T_A = -40°C to +85°C, V_{CC} = 5V ±10%)

Parameters	Description	Test Conditions ⁽¹⁾	Min.	Typ ⁽²⁾	Max.	Units	
V _{IH}	Input HIGH Voltage	Guaranteed Logic HIGH Level	2.0	—	—	V	
V _{IL}	Input LOW Voltage	Guaranteed Logic LOW Level	-0.5	—	0.8	V	
I _{IH}	Input HIGH Current	V _{CC} = Max., V _{IN} = V _{CC}	—	—	±1	μA	
I _{IL}	Input LOW Current	V _{CC} = Max., V _{IN} = GND	—	—	±1	μA	
I _{OZH}	High Impedance Output Current	0 ≤ A, B ≤ V _{CC}	—	—	±1	μA	
V _{IK}	Clamp Diode Voltage	V _{CC} = Min., I _{IN} = -18mA	—	-0.7	-1.2	V	
I _{OS}	Short Circuit Current ⁽³⁾	A (B) = 0V, B (A) = V _{CC}	100	—	—	mA	
V _H	Input Hysteresis at Control Pins		—	150	—	nV	
R _{ON}	Switch On Resistance ⁽⁴⁾	V _{CC} = Min., V _{IN} = 0.0V, I _{ON} = 48mA	16245	—	5	7	Ω
			162245	20	28	40	
		V _{CC} = Min., V _{IN} = 2.4V, I _{ON} = 15mA	16245	—	10	15	Ω
			162245	20	35	48	

Capacitance (T_A = 25°C, f = 1 MHz)

Parameters ⁽⁵⁾	Description	Test Conditions	Typ	Max.	Units
C _{IN}	Input Capacitance	V _{IN} = 0V	—	6	pF
C _{OFF}	A/B Capacitance, Switch Off	V _{IN} = 0V	—	6	pF
C _{ON}	A/B Capacitance, Switch On	V _{IN} = 0V	—	8	pF

Notes:

1. For Max. or Min. conditions, use appropriate value specified under Electrical Characteristics for the applicable device type.
2. Typical values are at V_{CC} = 5.0V, T_A = 25°C ambient and maximum loading.
3. Not more than one output should be shorted at one time. Duration of the test should not exceed one second.
4. Measured by the voltage drop between A and B pins at indicated current through the switch. ON resistance is determined by the lower of the voltages on the two (A,B) pins.
5. This parameter is determined by device characterization but is not production tested.

Power Supply Characteristics

Parameters	Description	Test Conditions ⁽¹⁾		Min.	Typ ⁽²⁾	Max.	Units
I _{CC}	Quiescent Power Supply Current	V _{CC} =Max.	V _{IN} =GND or V _{CC}	—	0.1	3.0	μA
ΔI _{CC}	Supply Current per Input @ TTL HIGH	V _{CC} =Max.	V _{IN} =3.4V ⁽³⁾	—	—	2.5	mA
I _{CCD}	Supply Current per Input per MHz ⁽⁴⁾	V _{CC} =Max., A and B Pins Open nBE=GND Control Input Toggling 50% Duty Cycle		—	—	0.25	mA/ MHz

Notes:

1. For Max. or Min. conditions, use appropriate value specified under Electrical Characteristics for the applicable device.
2. Typical values are at V_{CC} = 5.0V, +25°C ambient.
3. Per TTL driven input (V_{IN} = 3.4V, control inputs only); A and B pins do not contribute to I_{CC}.
4. This current applies to the control inputs only and represent the current required to switch internal capacitance at the specified frequency. The A and B inputs generate no significant AC or DC currents as they transition. This parameter is not tested, but is guaranteed by design.

PI5C16245 Switching Characteristics over Operating Range

Parameters	Description	Conditions	PI5C16245		Units
			Com.		
			Min.	Max.	
t _{PLH} t _{PHL}	Propagation Delay ^(2,3) xAx to xBx, xBx to xAx,	C _L = 50pF R _L = 500Ω	—	0.25	ns
t _{PZH} t _{PZL}	Bus Enable Time xBE to xAx or xBx,		1.5	6.5	
t _{PHZ} t _{PLZ}	Bus Disable Time xBE to xAx or xBx,		1.5	5.5	

PI5C162245 Switching Characteristics over Operating Range

Parameters	Description	Conditions	PI5C162245		Units
			Com.		
			Min.	Max.	
t _{PLH} t _{PHL}	Propagation Delay ^(2,3) xAx to xBx, xBx to xAx,	C _L = 50pF R _L = 500Ω	—	1.25	ns
t _{PZH} t _{PZL}	Bus Enable Time xBE to xAx or xBx,		1.5	6.5	
t _{PHZ} t _{PLZ}	Bus Disable Time xBE to xAx or xBx,		1.5	5.5	

Notes:

1. See test circuit and waveforms.
2. This parameter is guaranteed but not tested on Propagation Delays.
3. The bus switch contributes no propagational delay other than the RC delay of the ON resistance of the switch and the load capacitance. The time constant for the switch alone is of the order of 0.25ns for 50pF load. Since this time constant is much smaller than the rise/fall times of typical driving signals, it adds very little propagational delay to the system. Propagational delay of the bus switch when used in a system is determined by the driving circuit on the driving side of the switch and its interaction with the load on the driven side.

Applications Information

Logic Inputs

The logic enable inputs can be driven up to +5.5V regardless of the supply voltage. For example, given a +5.0V supply, the enable pins(s) may be driven low to 0V and high to 5.5V. Driving the enable pin(s) Rail-to-Rail® minimizes power consumption.

Power-Supply Sequencing

Proper power-supply sequencing is recommended for all CMOS devices. Always apply Vcc before applying signals to the input/output or control pins.

Rail-to-Rail is a registered trademark of Nippon Motorola.

Ordering Information

Part	Pin Package	Temperature
PI5C16245A	48-TSSOP (A)	-40°C to +85°C
PI5C16245B	48-BQSOP (B)	
PI5C16245V	48-SSOP (V)	

48-Pin TSSOP (240 Mil Wide) - Package Code: A

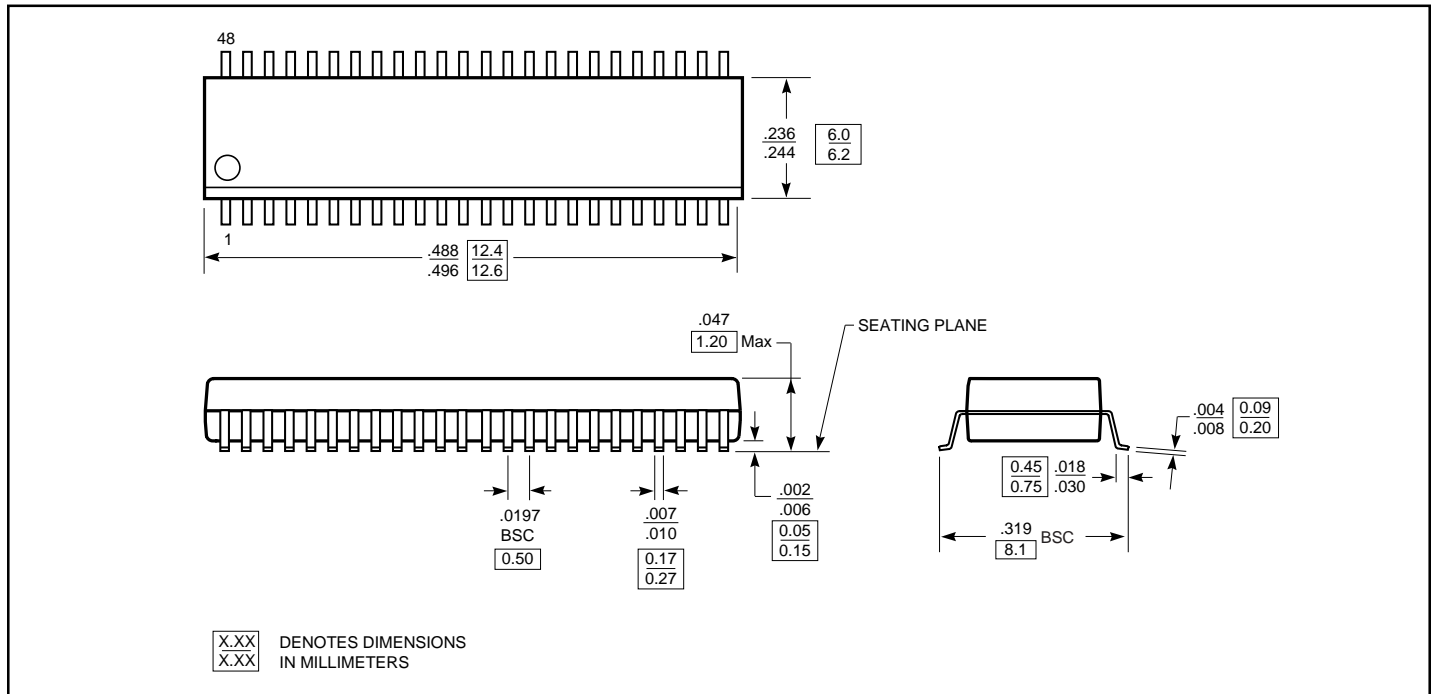

48-Pin BQSOP (150 Mil Wide) - Package Code: B

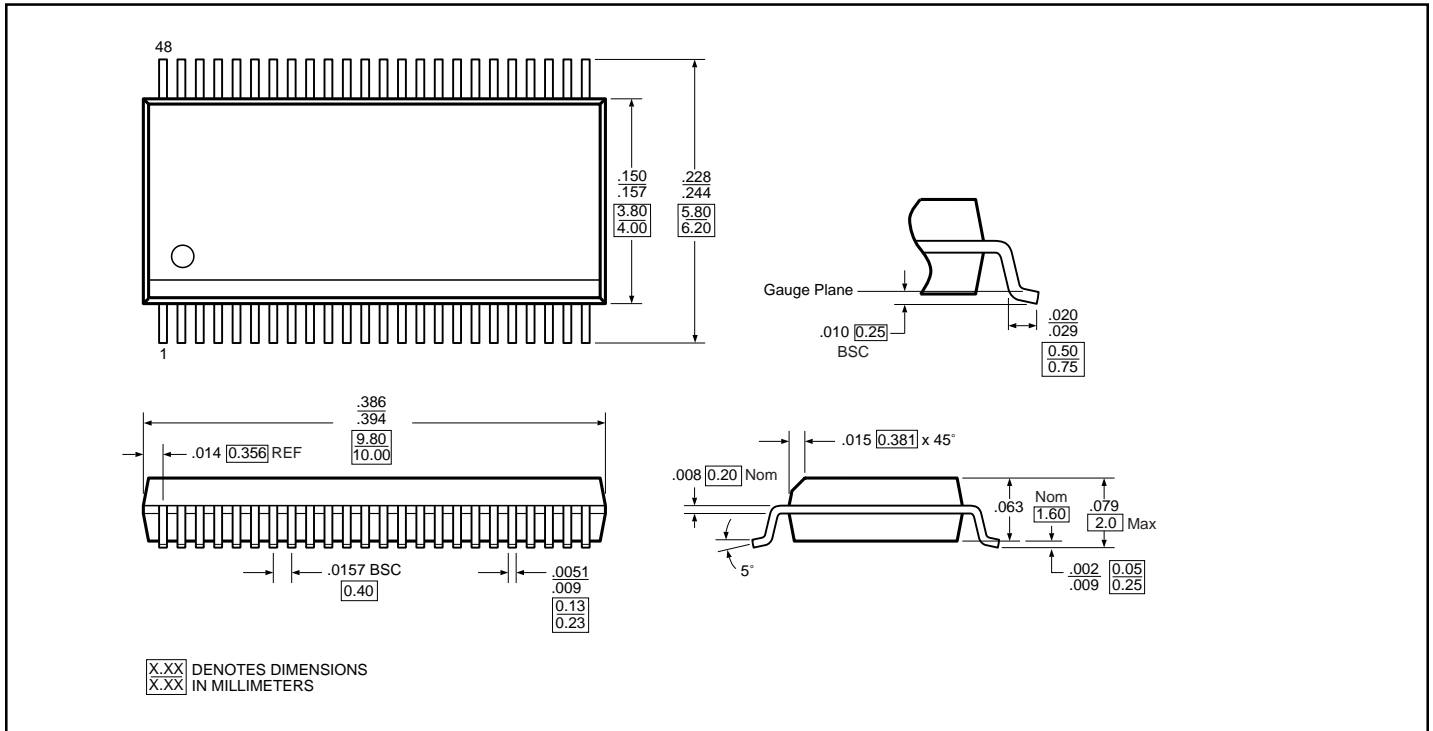

48-Pin SSOP (300 Mil Wide) - Package Code: V

