



# PJLC1V5

## LOW CAPACITANCE ESD / TRANSIENT DATA LINE PROTECTOR FOR 1.5V SYSTEMS

**VOLTAGE**

**1.5 Volts**

**POWER**

**50 Watts**

**SOT-23**

Unit: inch (mm)

### FEATURES

- Off-State Capacitance typical of 6pF, max 10pF @ 1MHz 0Vdc
- Maximum Leakage Current of 1  $\mu$  A @ 1.5V
- Breakdown Voltage of 2.2V @ 1mA
- IEC61000-4-2 Compliance (8kV Air, 15kV Contact Discharge)
- Industry Standard Surface Mount Package SOT23
- Pb free product are available : 99% Sn above can meet RoHS environment substance directive request

### APPLICATIONS

- High Speed Data Lines
- Microcontroller and Microprocessor I/O interfaces
- Mobile Phone and PDA's
- LAN/WAN Equipment
- Instrumentation Equipment

### MECHANICAL DATA

- Case: Molded Plastic SOT-23
- Marking : T1L

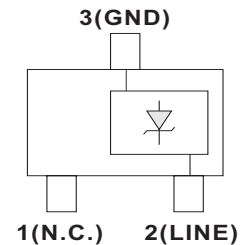
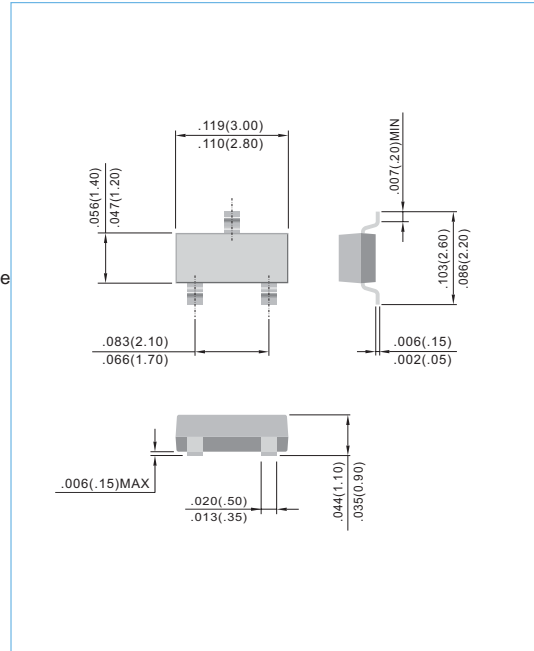

### MAXIMUM RATINGS

PATING	SYMBOL	VALUE	UNITS
Peak Pulse Power ( 8/20 $\mu$ s Waveform )	P <sub>PK</sub>	50	W
ESD Voltage (per IEC61000-4-2)	V <sub>ESD</sub>	25	kV
Lead Soldering Temperature ( max 10 seconds )	T <sub>L</sub>	260	°C
Operating Temperature Range	T <sub>J</sub>	-50 to 150	°C
Storage Temperature Range	T <sub>STG</sub>	-50 to 150	°C
Maximum Peak Pluse Current	I <sub>PP</sub>	1	A



**ELECTRICAL CHARACTERISTICS**

PARAMETER	SYMBOL	CONDITIONS	MIN.	TYPICAL	MAX.	UNITS
Reverse Stand-Off Voltage	$V_{RWM}$				1.5	V
Reverse Breakdown Voltage	$V_{BR}$	@100 $\mu$ A @1mA	1.75 2.1	1.8 2.2		V
Reverse Leakage Current	$I_R$	$V_{RWM}=1.5V$ @ $T_A=25^\circ C$			1	$\mu$ A
Clamping Voltage	$V_C$	$I_{PP}=1A$ @8/20 $\mu$ s			4	V
Clamping Voltage	$V_C$	$I_{PP}=3A$ @8/20 $\mu$ s			7	V
Off-State Capacitance	$C_J$	Pin 1 to Pin 3 1MHz, 0Vdc		6	10	pF

**RATING AND CHARACTERISTICS CURVES**

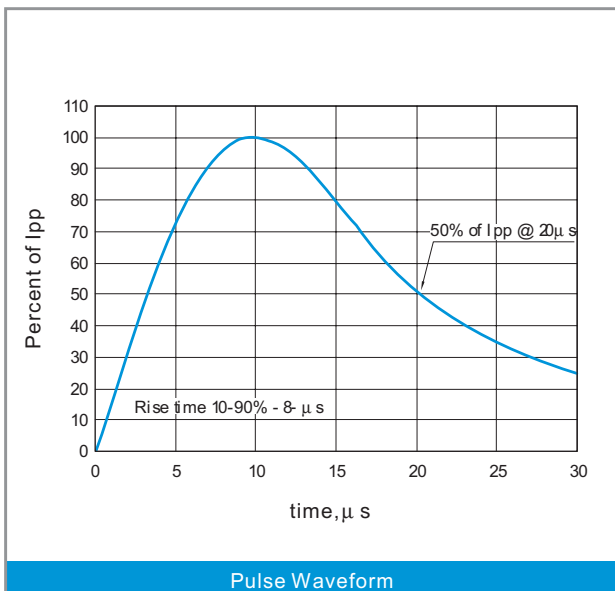
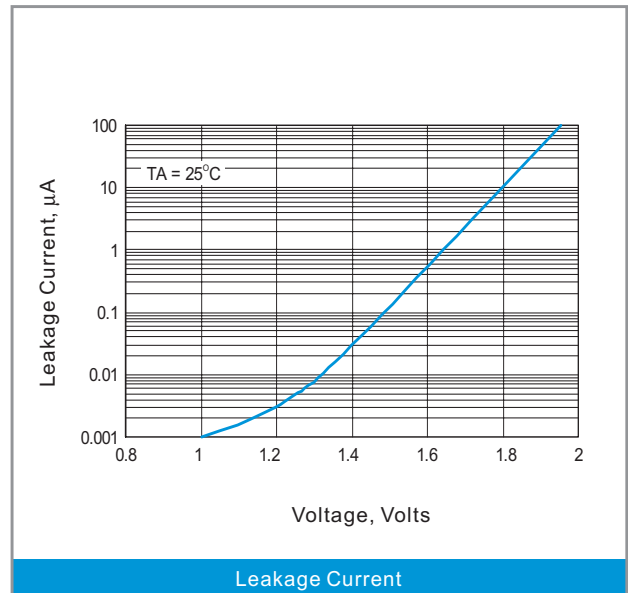
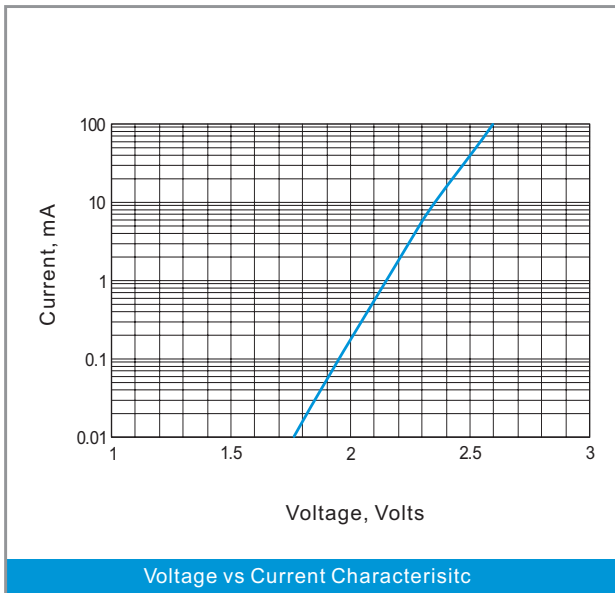



**Typical Application Configuration (Shown for two data lines)**

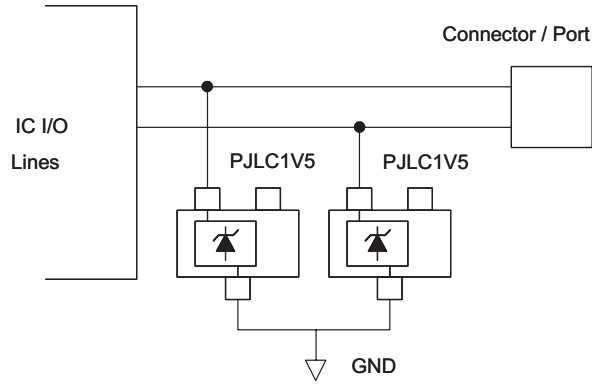

**MOUNTING PAD LAYOUT**

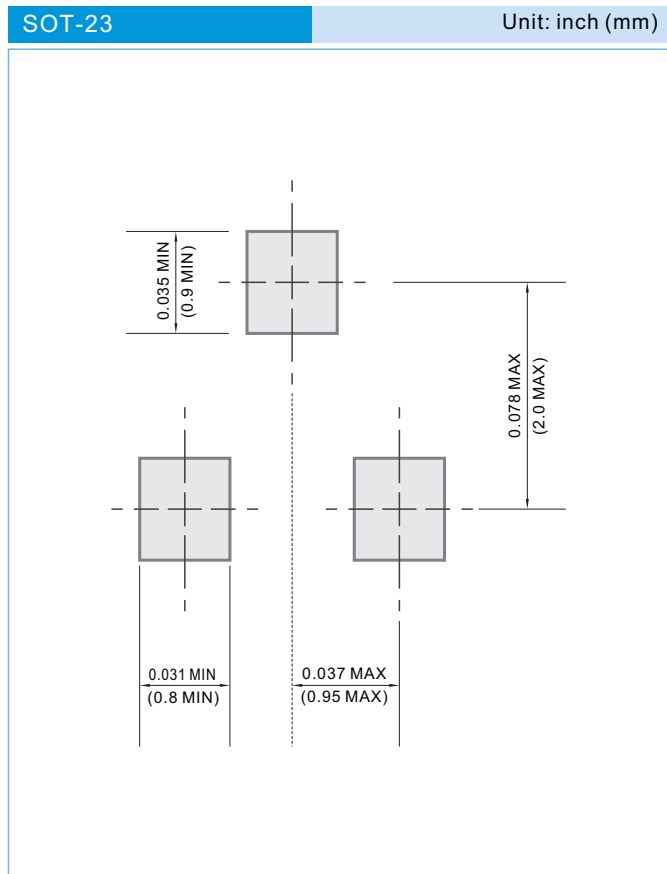



---

## ORDER INFORMATION

---

- Packing information
  - T/R - 12K per 13" plastic Reel
  - T/R - 3.0K per 7" plastic Reel

---

## LEGAL STATEMENT

---

### IMPORTANT NOTICE

This information is intended to unambiguously characterize the product in order to facilitate the customer's evaluation of the device in the application. The information will help the customer's technical experts determine that the device is compatible and interchangeable with similar devices made by other vendors. The information in this data sheet is believed to be reliable and accurate. The specifications and information herein are subject to change without notice. New products and improvements in products and product characterization are constantly in process. Therefore, the factory should be consulted for the most recent information and for any special characteristics not described or specified.

### Copyright Pan Jit International Inc. 2003

All rights reserved. Reproduction in whole or in part is prohibited without the prior written consent of the copyright owner.

The information presented in this document does not form part of any quotation or contract. The information presented is believed to be accurate and reliable, and may change without notice in advance. No liability will be accepted by the publisher for any consequence of use. Publication thereof does not convey nor imply any license under patent or other industrial or intellectual property rights.