



PL-2301 USB TO USB BRIDGE CONTROLLER

OVERVIEW

The PL-2301 USB-to-USB Bridge Controller is a low-cost high-performance single chip solution that provides bi-directional connectivity between any standard USB compliant host systems. Unlike previous file transfer methods like serial cable, parallel cable and IrDA, the PL-2301 chip has a more advanced bus protocol and operation system that offers much higher bandwidth and easier user interface.

The PL-2301 controller chip can be embedded into the link cable. Both sides of the cable function as an upstream connector that could join a USB network such as the USB port of a PC or the downstream port of a USB hub. Through switching and protocol adjustment in the controller chip, any two PCs or USB hosts can communicate with each other while adopting maximum speed for bulk-type data formats. In addition, data are allowed to flow in both directions simultaneously without compromising on performance. Both PCs can control the device using standard USB command; the data flow is directed by a vendor-specific scheme.

FEATURES

- Transfers files between two PCs with USB interface
- Full compliance with the Universal Serial Bus Specification Version 1.1
- USB full-speed connection
- Double data buffer supporting two-way data transfer
- Low power consumption
- Supports suspend and resume power management
- Supports remote wake-up
- PnP drivers running under WinNT, Win98 and Win95 OSR 2.1
- Bus powered from either USB port
- Suitable for mobile PC environment
- On-chip USB transceiver
- On-chip oscillator using one 12 MHz crystal
- No glue logic needed and can be embedded in small space
- 28-Pin SSOP package

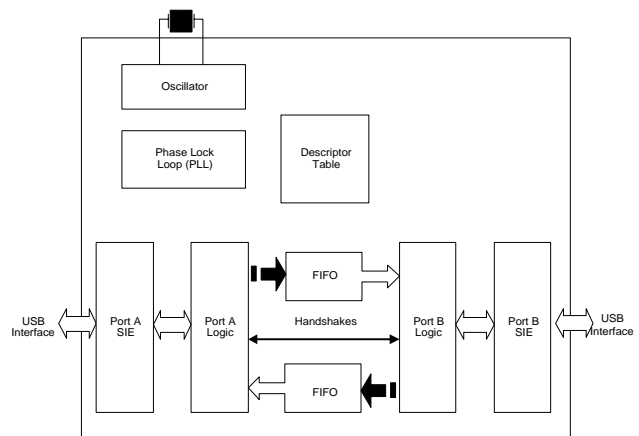

As shown in the block diagram above, this ASIC contains two USB units working independently. Together with the two FIFOs and control logic in between, they exchange data without blocking. The entire clock oscillator, PLL, voltage regulators, USB transceivers, and power-on reset circuits are integrated on the chip. There is no glue logic needed.

Prolific Technology Inc.

7F, No.48,Sec.3,Nan Kang Rd.,
Nan Kang, Taipei,115,Taiwan,R.o.c.
Tel : 886-2-2654-6363
Fax : 886-2-2654-6161
E-mail : sales@prolific.com.tw
<http://www.prolific.com.tw>

Windows is a registered trademark of Microsoft Corporation. © 1999, Prolific Technology Inc.
All rights reserved. March/1999

