

155 Mb/s SATURN User Network Interface for LANs

FEATURES

- Low-cost, monolithic SATURN® SONET/SDH ATM User Network Interface (UNI).
- Implements the ATM transmission convergence (TC) sublayer according to ATM Forum specifications using the SONET/SDH 155.52 Mbit/s STS- 3c/ STM-1, and 51.84 Mbit/s STS-1 formats.
- Supports ATM-Forum mid-range PHY and PMC-Sierra UNI-PHY™ substrates at 25.92 and 12.96 Mbit/s.
- Supports UTP-5 or STP twisted pair wiring interface devices and optical driver and receiver modules for fiber optic cable interfaces.
- Includes on-chip, Bellcore-compliant clock recovery and clock synthesis.
- Operates in timing master or timing slave (loop timed) modes.
- Frames to SONET/SDH framing bytes (A1 and A2), processes the section and line Bit Interleaved Parity (B1 and B2) and the Far-End Block Error (Z2) bytes.
- Interprets the H1, H2, and H3 payload pointer bytes.
- Processes the SONET path overhead BIP-8 (B3), signal label (C2), and path status (G1) bytes.
- Inserts and extracts ATM payloads using ATM cell delineation.
- Provides on-chip FIFO buffers in both transmit and receive paths.
- Provides on-chip support for Generic Flow Control (GFC) and XOFF flow control.
- Provides a synchronous, 8-bit, plus-parity SATURN-Compliant Interface for PHYSical layer devices (SCI-PHY™) bus operating at 33 MHz.
- Compatible with ATM Forum UTOPIA interface format, with support for multi-PHY applications.
- Provides a generic 8-bit microprocessor bus interface for configuration, control, and monitoring.
- Provides TTL-compatible inputs and outputs and differential PECL inputs.
- Low power, +5 V CMOS technology.
- Packaged in a 128-pin 14 mm by 20 mm Plastic Quad Flat Pack (PQFP) with 0.5 mm lead pitch.

APPLICATIONS

- 155.52, 51.84, 25.92 and 12.96 Mbit/s Twisted Pair or Optical ATM LANs
- Workstations and Personal Computer NIC Cards
- Switches, Hubs, and Router Port Cards
- SONET- or SDH-Compliant ATM UNIs

BLOCK DIAGRAM

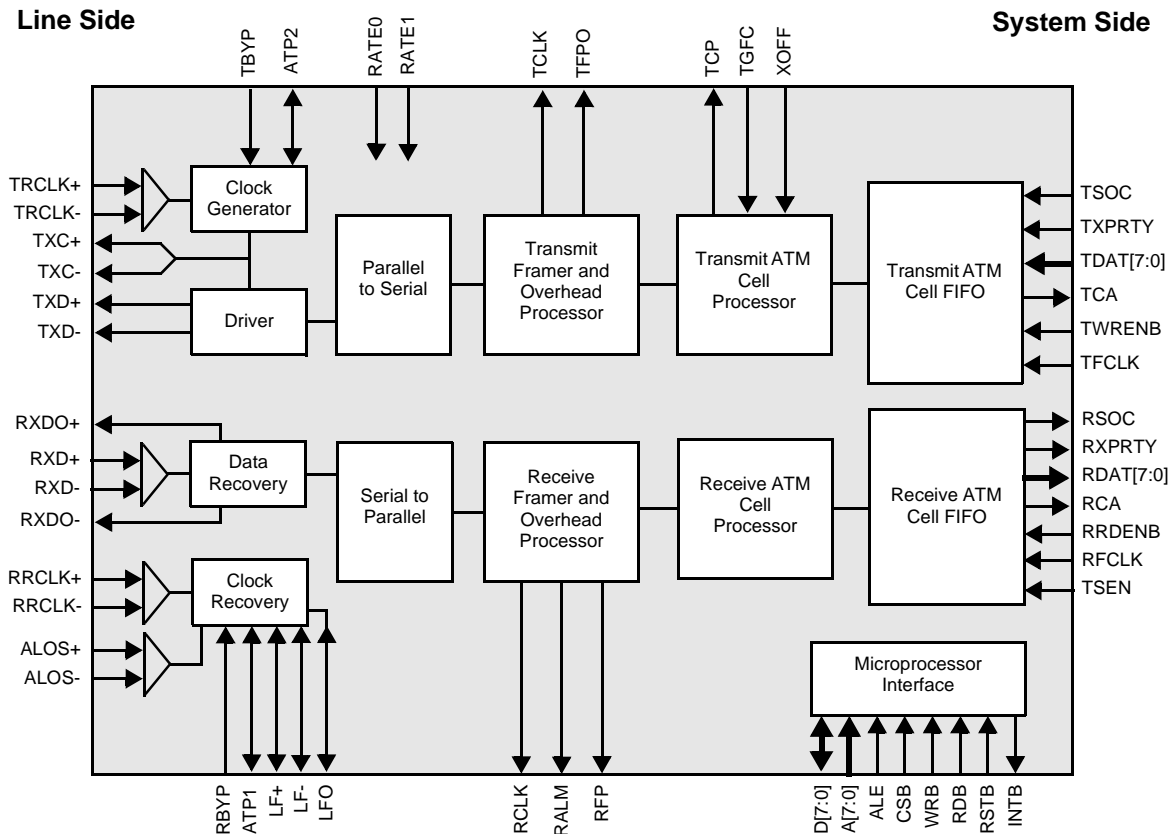

155 Mb/s SATURN User Network Interface for LANs

TYPICAL 155.52 Mbit/s JITTER PERFORMANCE

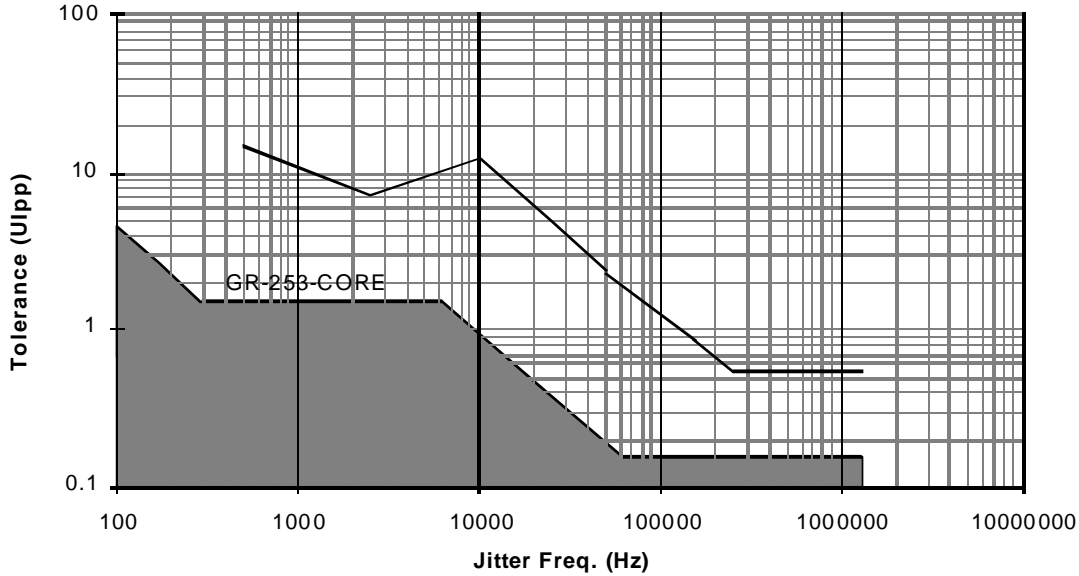

TYPICAL APPLICATION: UNI-PHY ATM TERMINAL

155.52 OR 51.84 Mbit/s NRZ PHY

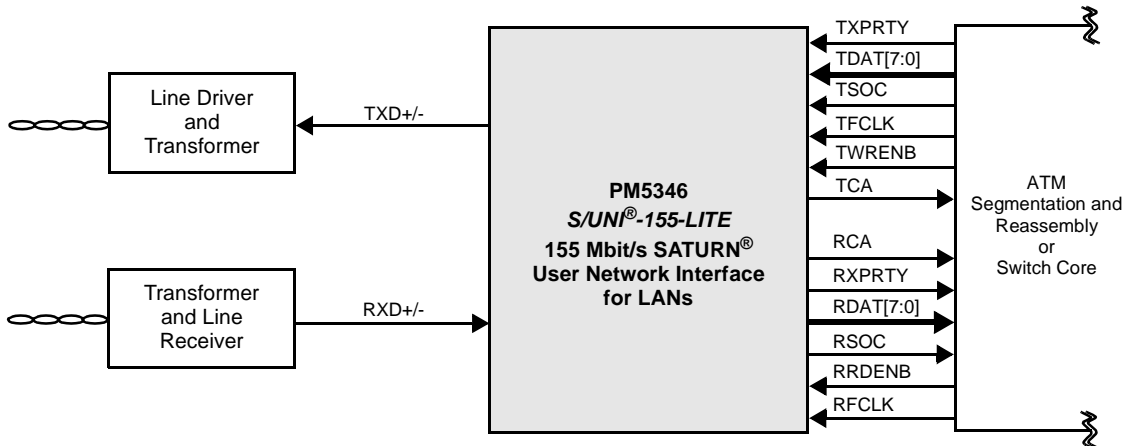

Head Office:
 PMC-Sierra, Inc.
 #105 - 8555 Baxter Place
 Burnaby, B.C. V5A 4V7
 Canada
 Tel: 604.415.6000
 Fax: 604.415.6200

To order documentation,
 send email to:
 document@pmc-sierra.com
 or contact the head office,
 Attn: Document Coordinator

All product documentation is
 available on our web site at:
 http://www.pmc-sierra.com
 For corporate information,
 send email to:
 info@pmc-sierra.com

This product contains
 patented ATM cell
 delineation technology under
 license from Cisco
 Systems, Inc.

PMC-930908 (R9)
 © 1998 PMC-Sierra, Inc.
 October, 1998
 SATURN, SCI-PHY,
 S/UNI-155-LITE, and UNI-PHY are
 trademarks of PMC-Sierra, Inc.