

NEC

HIGH ISOLATION VOLTAGE HIGH COLLECTOR TO EMITTER VOLTAGE SOP MULTI OPTOCOUPLER

PS2832-1,-4
PS2833-1,-4

FEATURES

- **HIGH COLLECTOR TO EMITTER VOLTAGE**
 $V_{CE0} = 300\text{ V}$: PS2832-1,-4
 $V_{CE0} = 350\text{ V}$: PS2833-1,-4
- **SMALL THIN PACKAGE**
4, 16-pin SOP, pin pitch 1.27 mm
- **HIGH ISOLATION VOLTAGE**
 $BV = 2500\text{ Vr.m.s.}$
- **HIGH CURRENT TRANSFER RATIO**
 $CTR = 2000\% \text{ TYP}$
- **TAPING PRODUCT NUMBER**
PS2832-1-F3, F4, PS2833-1-F3, F4
PS2832-4-F3, F4, PS2833-4-F3, F4

DESCRIPTION

PS2832-1,-4 and PS2833-1,-4 are optically coupled isolators containing a GaAs light emitting diode and an NPN silicon darlington-connected phototransistor. The package is an SSOP (Super Small Out-Line Package) type for high density mounting applications.

APPLICATIONS

- HYBRID IC
- TELEPHONE / TELEGRAPH RECEIVER
- FAX

ELECTRICAL CHARACTERISTICS ($T_A = 25^\circ\text{C}$)

		PART NUMBER	PS2832-1, -4, PS2833-1, -4			
	SYMBOLS	PARAMETERS	UNITS	MIN	TYP	MAX
Diode	V_F	Forward Voltage, $I_F = 10\text{ mA}$	V		1.2	1.4
	I_R	Reverse Current, $V_R = 5\text{ V}$	μA			5
	C	Terminal Capacitance, $V = 0, f = 1.0\text{ MHz}$	pF		15	
Tran-sistor	I_{CE0}	Collector to Emitter Current $I_F = 0\text{ mA}, V_{CE} = 300\text{ V}$	nA			400
Coupled	CTR	Current Transfer Ratio, (I_C/I_F) $I_F = 1\text{ mA}, V_{CE} = 2\text{ V}$	%	400	2000	4500
	$V_{CE(sat)}$	Collector Saturation Voltage, $I_F = 1\text{ mA}, I_C = 2\text{ mA}$	V			1.0
	Ri-o	Isolation Resistance, $V_{in-out} = 1.0\text{ kVDC}$	Ω	10^{11}		
	CI-o	Isolation Capacitance, $V = 0, f = 1.0\text{ MHz}$	pF		0.4	
	t_r	Rise Time ¹ , $V_{CC} = 5\text{ V}, I_C = 10\text{ mA}, R_L = 100\ \Omega$	μs		20	
t_f	Fall Time ¹ , $V_{CC} = 5\text{ V}, I_C = 10\text{ mA}, R_L = 100\ \Omega$	μs		5		

1. Test Circuit for Switching Time

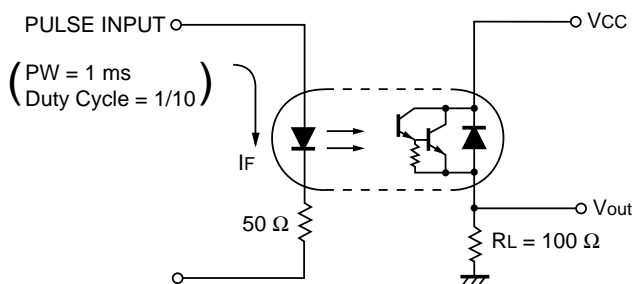

PS2832-1, -4, PS2833-1, -4

ABSOLUTE MAXIMUM RATINGS¹ (T_A = 25°C)

SYMBOLS	PARAMETERS	UNITS	RATINGS			
			PS2832-1	PS2833-1	PS2832-4	PS2833-4
Diode						
I _F	Forward Current (DC)	mA	50			
V _R	Reverse Voltage	V	6			
ΔP _D /°C	Power Dissipation Derating	mW/°C	0.6		0.8	
P _D	Power Dissipation	mW/Ch	60		80	
I _{F(Peak)}	Peak Forward Current PW = 100 μs, Duty Cycle 1%	A	1			
Transistor						
V _{CEO}	Collector to Emitter Voltage	V	300	350	300	350
V _{ECO}	Emitter to Collector Voltage	V	0.3			
I _C	Collector Current	mA/Ch	60			
ΔP _C /°C	Power Dissipation Derating	mW/°C	1.2			
P _C	Power Dissipation	mW/Ch	120			
Coupled						
BV	Isolation Voltage ²	V _{r.m.s.}	2500			
T _A	Operating Ambient Temp.	°C	-55 to +100			
T _{STG}	Storage Temperature	°C	-55 to +150			

Notes:

- Operation in excess of any one of these parameters may result in permanent damage.
- AC voltage for 1 minute at T_A = 25 °C, RH = 60 % between input and output.

OUTLINE DIMENSIONS (Units in mm)

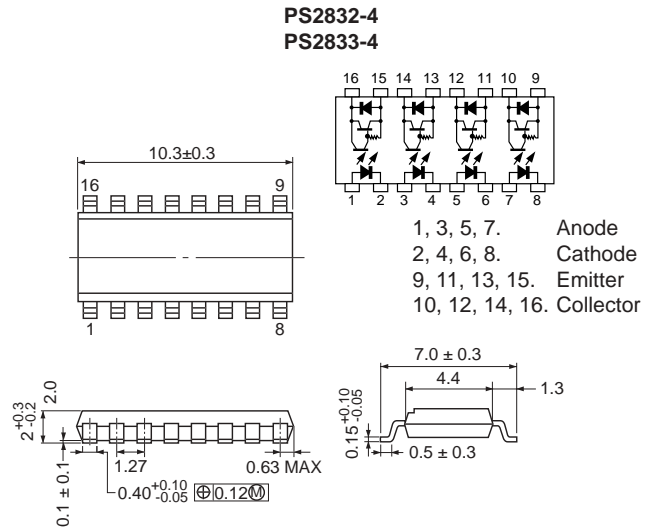
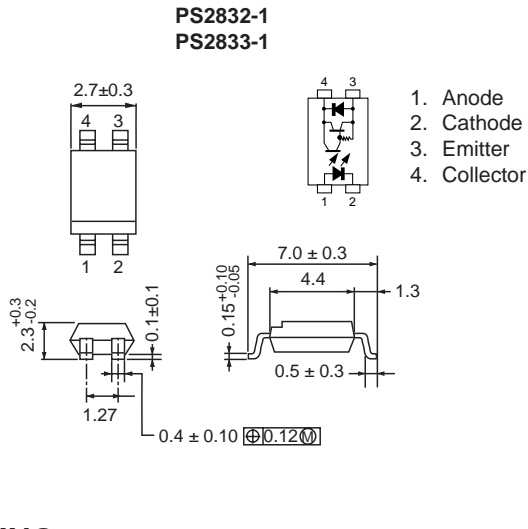

MARKING

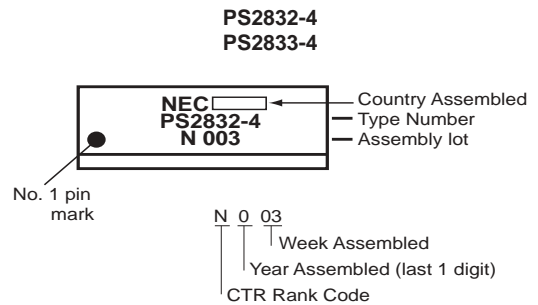
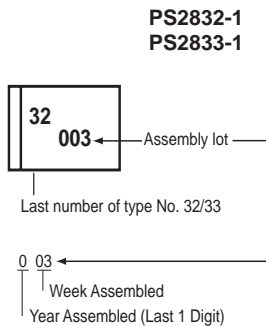

TYPICAL PERFORMANCE CURVES ($T_A = 25^\circ\text{C}$ unless otherwise specified)

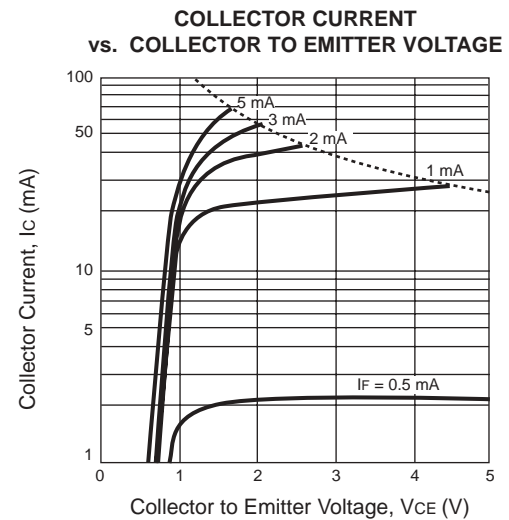
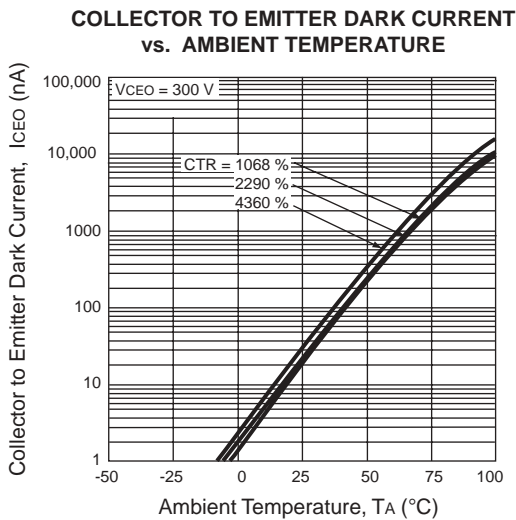
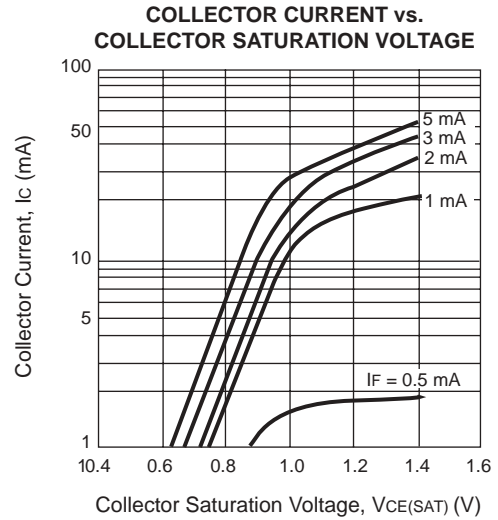
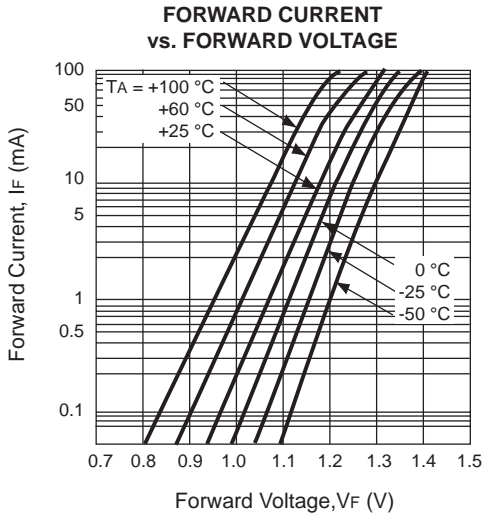
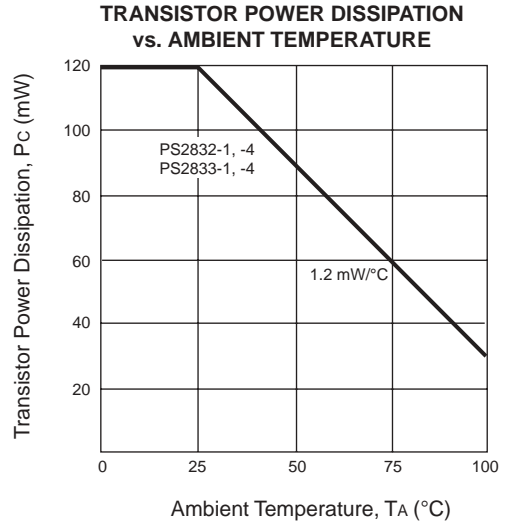
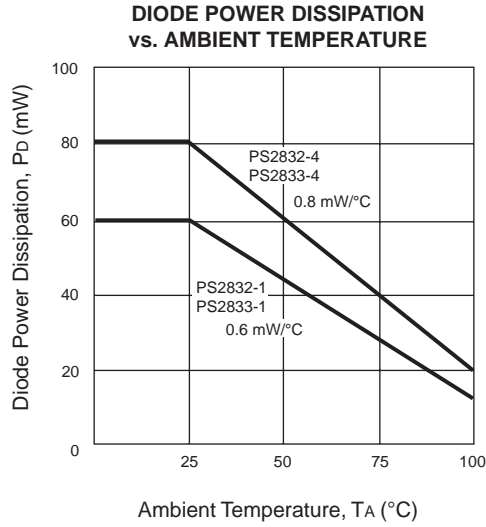

TYPICAL PERFORMANCE CURVES (TA = 25°C unless otherwise specified)

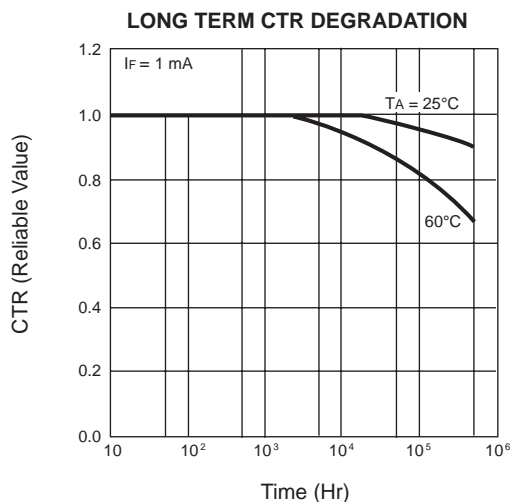
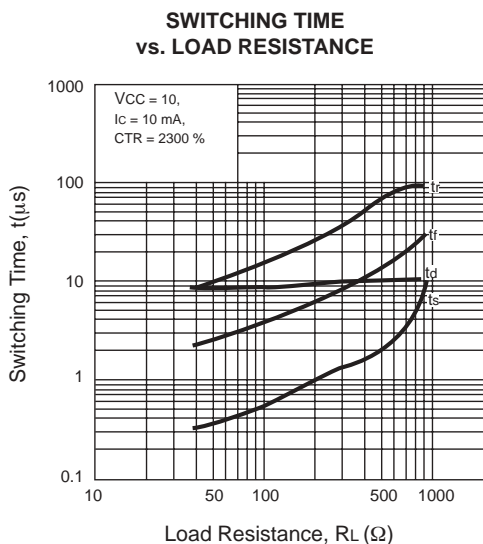
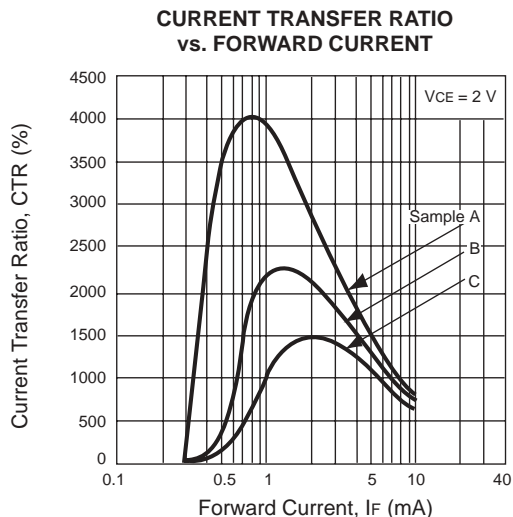
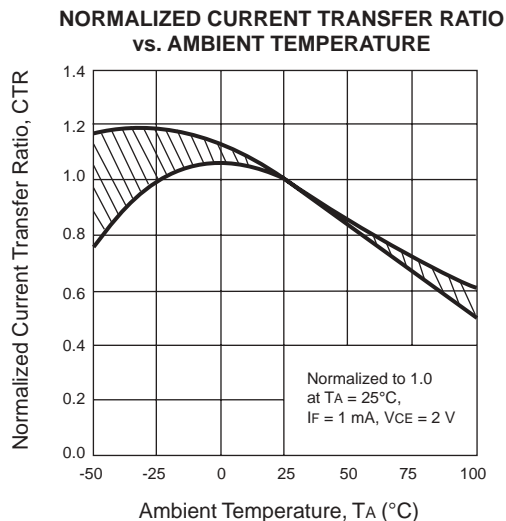

Remark: The graphs indicate nominal characteristics.

ORDERING INFORMATION

PART NUMBER	PACKAGE	PACKING STYLE	PART NUMBER	PACKAGE	PACKING STYLE
PS2832-1	4 pin SOP	50 pcs (Tape 50 pcs cut)	PS2833-1	4 pin SOP	50 pcs (Tape 50 pcs cut)
PS2832-1-F3		Embossed Tape 3500 pcs/reel	PS2833-1-F3		Embossed Tape 3500 pcs/reel
PS2832-1-F4			PS2833-1-F4		
PS2832-4	16 pin SOP	Magazine case 45 pcs	PS2833-4	16 pin SOP	Magazine case 45 pcs
PS2832-4-F3		Embossed Tape 2500 pcs/reel	PS2833-4-F3		Embossed Tape 2500 pcs/reel
PS2832-4-F4			PS2833-4-F4		
PS2832-1-V	4 pin SOP	50 pcs (Tape 50 pcs cut)	PS2833-1-V	4 pin SOP	50 pcs (Tape 50 pcs cut)
PS2832-1-V-F3		Embossed Tape 3500 pcs/reel	PS2833-1-V-F3		Embossed Tape 3500 pcs/reel
PS2832-1-V-F4			PS2833-1-V-F4		
PS2832-4-V	16 pin SOP	Magazine case 45 pcs	PS2833-4-V	16 pin SOP	Magazine case 45 pcs
PS2832-4-V-F3		Embossed Tape 2500 pcs/reel	PS2833-4-V-F3		Embossed Tape 2500 pcs/reel
PS2832-4-V-F4			PS2833-4-V-F4		

TAPING SPECIFICATIONS (Units in mm)

TAPE OUTLINE AND DIMENSIONS

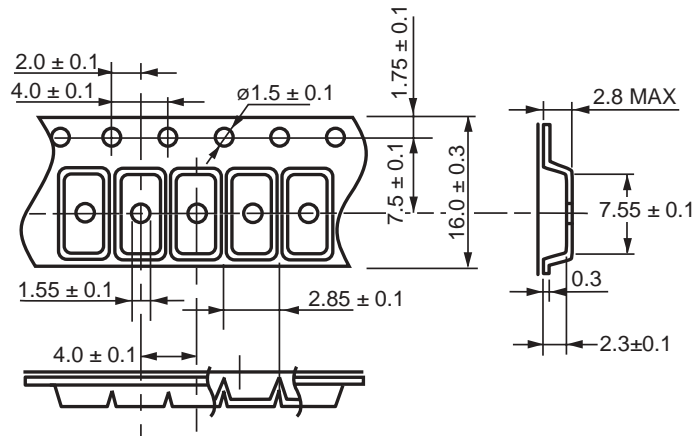

TAPE DIRECTION

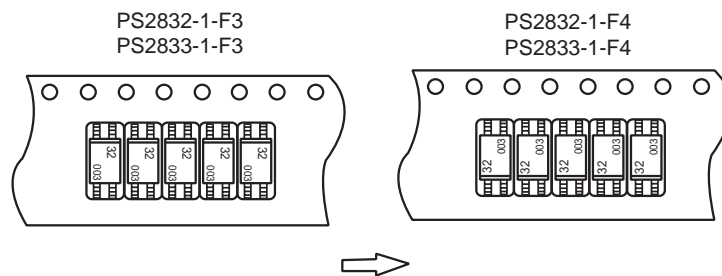

REEL OUTLINE DIMENSIONS

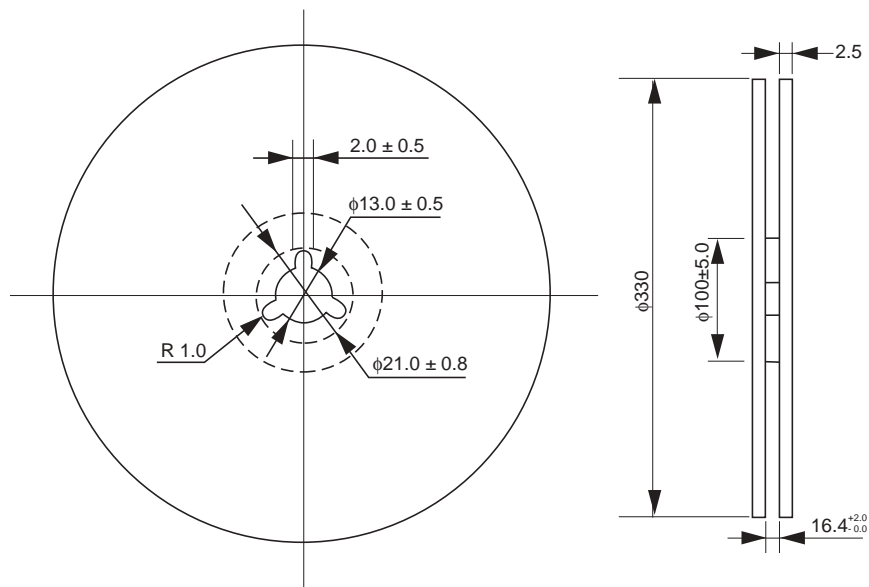

Packing: 3500 pcs/Reel

TAPING SPECIFICATIONS (Units in mm)

TAPE OUTLINE AND DIMENSIONS

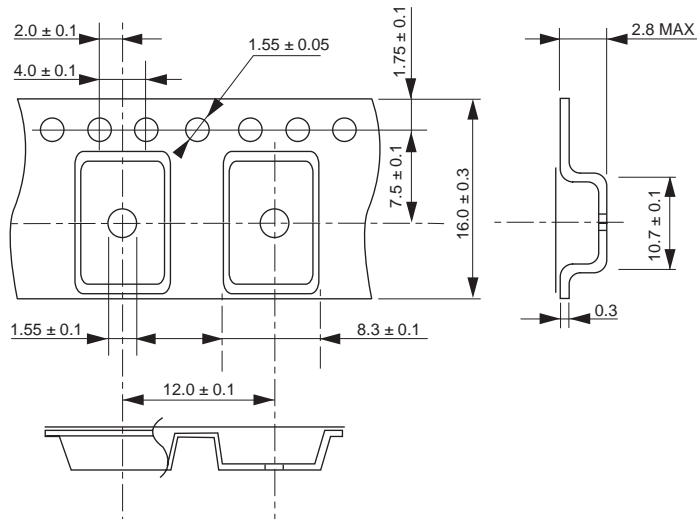

TAPE DIRECTION

PS2832-4-F3
PS2833-4-F3

PS2832-4-F4
PS2833-4-F4

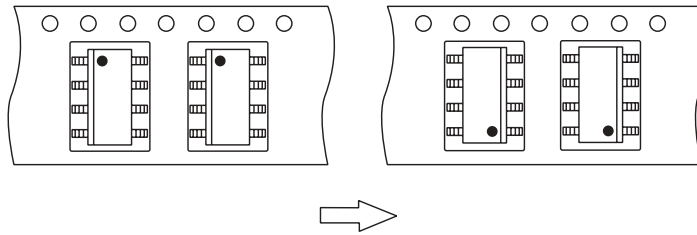

REEL OUTLINE DIMENSIONS

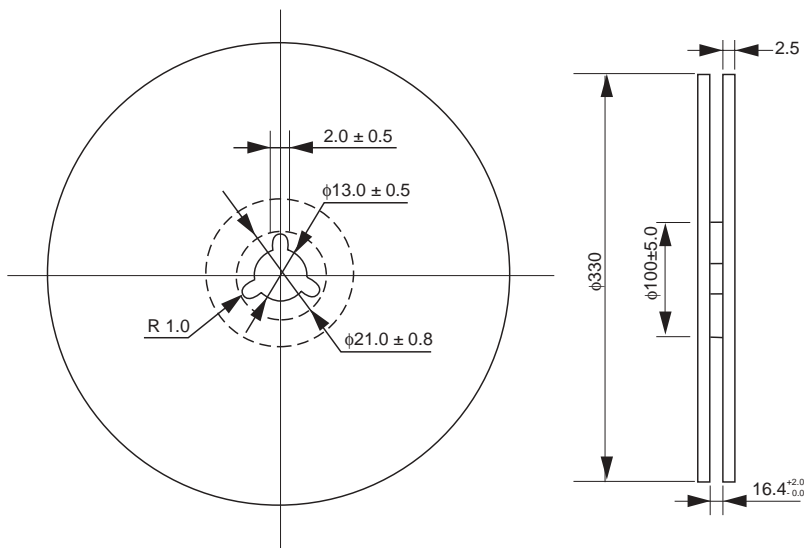

Packing: 2500 ppcs/reel

RECOMMENDED SOLDERING CONDITIONS

(1) Infrared reflow soldering

- Peak reflow temperature 235 °C (package surface temperature)
- Time of temperature higher than 210 °C 30 seconds or less
- Number of reflows Three
- Flux Rosin flux containing small amount of chlorine (The flux with a maximum chlorine content of 0.2 Wt % is recommended).

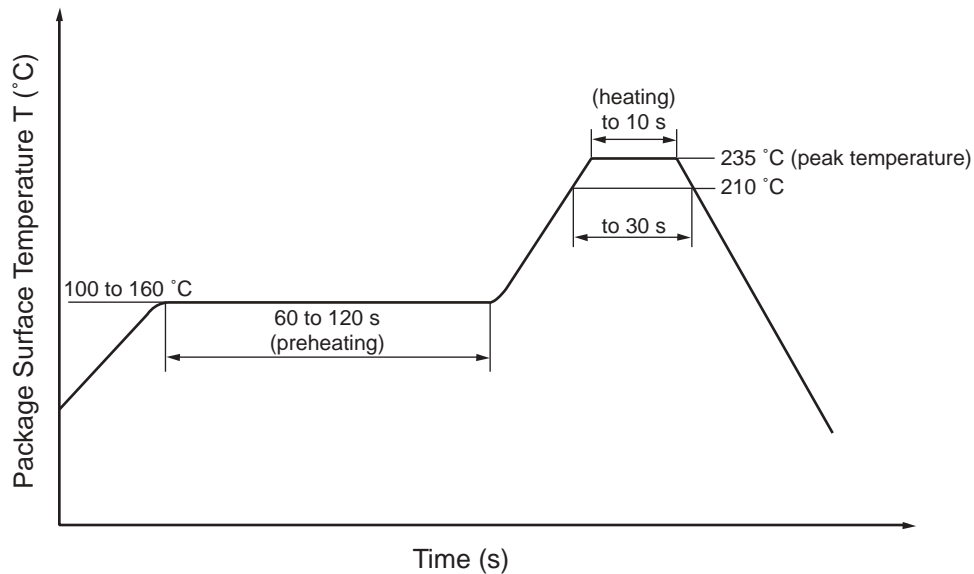

(2) Dip soldering

- Temperature 260 °C or below (molten solder temperature)
- Time 10 seconds or less
- Number of times One
- Flux Rosin flux containing small amount of chlorine (The flux with a maximum chlorine content of 0.2 Wt % is recommended).

(3) Cautions

- Fluxes Avoid removing the residual flux with chlorine-based cleaning solvent after a reflow process.

CAUTIONS REGARDING NOISE

Be aware that when voltage is applied suddenly between the photocoupler's input and output or between corrector-emitters at start-up, the output side may enter the on state, even if the voltage is within the absolute maximum ratings.

Life Support Applications

These NEC products are not intended for use in life support devices, appliances, or systems where the malfunction of these products can reasonably be expected to result in personal injury. The customers of CEL using or selling these products for use in such applications do so at their own risk and agree to fully indemnify CEL for all damages resulting from such improper use or sale.

EXCLUSIVE NORTH AMERICAN AGENT FOR NEC RF, MICROWAVE & OPTOELECTRONIC SEMICONDUCTORS

CEL CALIFORNIA EASTERN LABORATORIES • Headquarters • 4590 Patrick Henry Drive • Santa Clara, CA 95054-1817 • (408) 988-3500 • Telex 34-6393 • FAX (408) 988-0279
 DATA SUBJECT TO CHANGE WITHOUT NOTICE Internet: <http://WWW.CEL.COM>

01/24/2002