

PNP SILICON TRANSISTOR

DESCRIPTION

The UTC PZT4033 designed for high current general purpose amplifier applications.

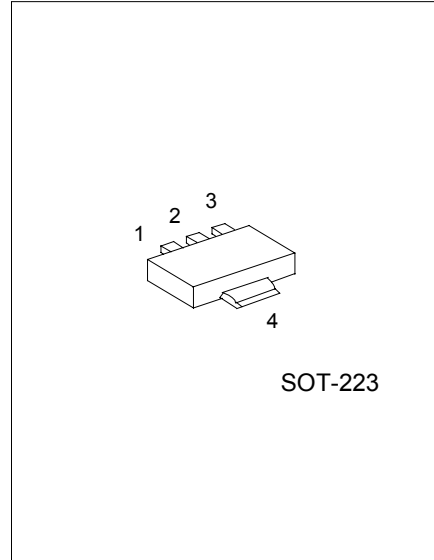

1:EMITTER 2,4:COLLECTOR 3:BASE

ABSOLUTE MAXIMUM RATINGS (Ta=25°C, unless otherwise specified)

PARAMETER	SYMBOL	RATING	UNIT
Collector-base voltage	V _{CB0}	-80	V
Collector-emitter voltage	V _{CEO}	-80	V
Emitter-base voltage	V _{EB0}	-5	V
Power dissipation	P _D	2	W
Collector current	I _c	-1	A
Junction Temperature	T _j	-65 ~ +150	°C
Storage Temperature	T _{STG}	-65 ~ +150	
Thermal Resistance	R _{θJA}	62.5	°C/W

ELECTRICAL CHARACTERISTICS (Ta=25°C, unless otherwise specified)

PARAMETER	SYMBOL	TEST CONDITIONS	MIN	TYP	MAX	UNIT
Collector-base breakdown voltage	BV _{CB0}	I _c =-10μA, I _E =0	-80			V
Collector-emitter breakdown voltage	BV _{CEO}	I _c =-10mA, I _B =0	-80			V
Emitter-base breakdown voltage	BV _{EB0}	I _E =-10μA, I _c =0	-5			V
Collector cut-off current	I _{CBO}	V _{CB} =-60V, I _E =0			-50	nA
Emitter cut-off current	I _{EBO}	V _{EB} =-5V, I _c =0			-10	nA
DC current gain(note)	h _{FE}	V _{CE} =-5V, I _c =-0.1mA	75		300	
		V _{CE} =-5V, I _c =-100mA	100			
		V _{CE} =-5V, I _c =-500mA	70			
		V _{CE} =-5V, I _c =-1A	25			
Collector-emitter saturation voltage	V _{CE(sat)}	I _c =-150mA, I _B =-15mA			-0.15	V
		I _c =-500mA, I _B =-50mA			-0.5	

UTC PZT4033

PNP EPITAXIAL SILICON TRANSISTOR

PARAMETER	SYMBOL	TEST CONDITIONS	MIN	TYP	MAX	UNIT
Base-emitter saturation voltage	$V_{BE(sat)}$	$I_c = -150\text{mA}, I_b = -15\text{mA}$ $I_c = -500\text{mA}, I_b = -50\text{mA}$			-0.9 -1.1	V
Gain Bandwidth Product	f_t	$V_{CE} = -10\text{V}, I_c = -50\text{mA}, f = 1\text{MHz}$	100			MHz
Output capacitance	C_{ob}	$V_{CB} = -10\text{V}, I_E = 0, f = 1\text{MHz}$			20	pF
Input capacitance	C_{ib}	$V_{EB} = -0.5\text{V}, I_C = 0, f = 1\text{MHz}$			110	pF
Switching Time	Turn-on Time	t_{on}			100	ns
	Storage Time	t_{stg}			350	ns
	Fall Time	t_f			50	ns

TYPICAL PARAMETERS PERFORMANCE

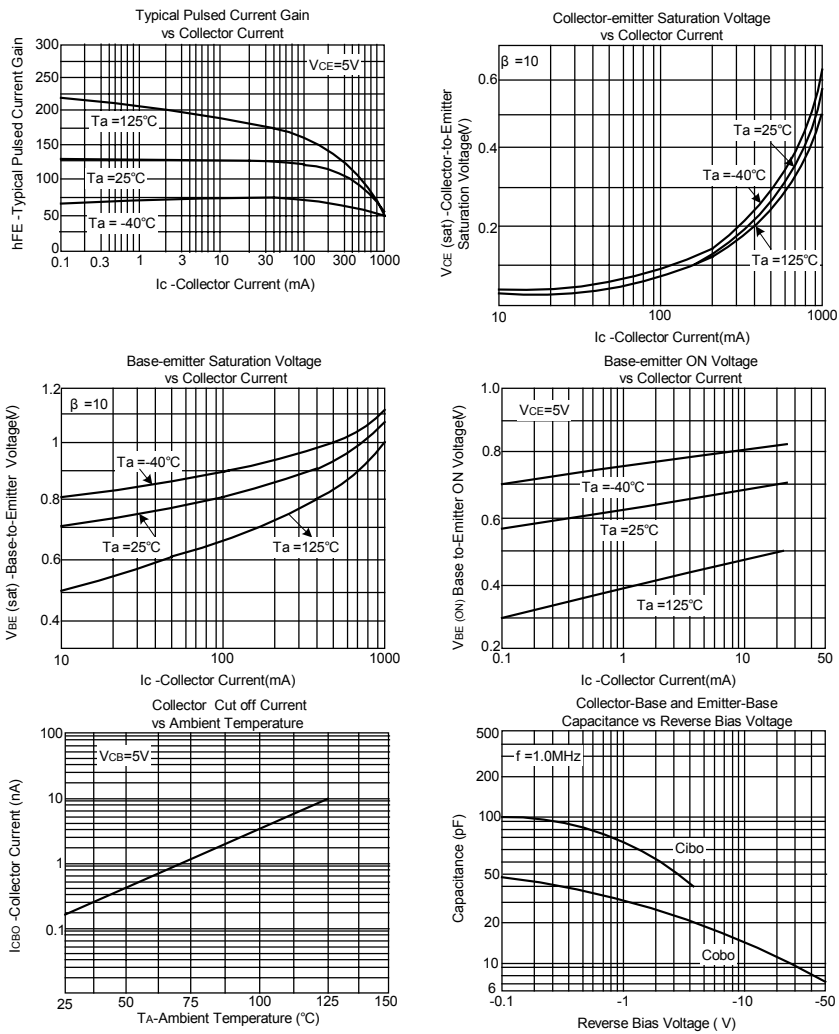

UTC PZT4033

PNP EPITAXIAL SILICON TRANSISTOR

UTC assumes no responsibility for equipment failures that result from using products at values that exceed, even momentarily, rated values (such as maximum ratings, operating condition ranges, or other parameters) listed in products specifications of any and all UTC products described or contained herein. UTC products are not designed for use in life support appliances, devices or systems where malfunction of these products can be reasonably expected to result in personal injury. Reproduction in whole or in part is prohibited without the prior written consent of the copyright owner. The information presented in this document does not form part of any quotation or contract, is believed to be accurate and reliable and may be changed without notice.