



Device Highlights

LVDS SERDES Basic Features

- 10 High Speed Bus LVDS Serial Links—bandwidth up to 5 Gbps
- Eight Independent Bus LVDS serial transceivers with operating speeds to 632 Mbps per channel
- Two Independent Bus LVDS clock serial transceivers with operating speeds to 400 MHz per channel
- Integrated clock and data recovery (CDR) with no external analog components required
- CDR bypass for applications with external clock source
- Programmable serial to parallel configuration
- 10-bit data width—with
- clock recovery
- 4-bit, 7-bit and 8-bit data widths—with external clock
- 1-bit asynchronous level conversion
- Fast Lock and Random (auto) Lock capable
- Lock signal feedback
- I/O support for LVTTTL, LVCMOS, PCI, GTL+, SSTL2, SSTL3, LVDS, LVPECL
- Low Power/Independent power-down mode for each SERDES channel
- IEEE1149.1 JTAG Support & boundary scan
- Operation over PCB or backplane traces, or across twisted pair cabling up to 25 m
- Point-to-Point, Multi-Point, and Multi-Drop Support
- Pre-Emphasis Control on each LVDS Channel Link

Extended Features

The following can be implemented into the programmable logic:

- UTOPIA Level 2, 16-bit wide System interface (up to 50 MHz) with parity support for ATM applications
- UTOPIA Level 3 compatible 8-bit wide system Interface (up to 100 MHz) with parity support for ATM applications
- CSIX-L1 32-bit switch fabric interface (up to 100 MHz)
- Supports Generic 8,16,32-bit microprocessor bus interface for configuration, control and status monitoring
- Supports Generic 32, 64-bit peripheral bus interface for bridging functions

Flexible Programmable Logic

- 2,016 Programmable Logic Cells
- 536 K System Gates
- Muxed architecture; non-volatile technology
- Completely customizable for any digital application

Dual Port SRAM Blocks

- 36 Dual Port SRAM Blocks
- Configurable array sizes (by 2, 4, 9, 18)
- < 3 ns access times, FIFO capable of over 300 MHz
- Configurable as RAM or FIFO



Programmable I/O

- Up to 252 Programmable I/O pins
- High performance Enhanced I/O (EIO): Less than 3 ns Tco
- Programmable Slew Rate Control
- Programmable I/O Standards
- LVTTTL, LVCMOS, PCI, GTL+, SSTL2, and SSTL3, LVDS, LVPECL
- Four Independent I/O Banks
- Three Register Configuration: Input, Output, OE

Embedded Computational Unit (ECU) Blocks

- Integrated multiply, add, and accumulate function
- 18 distributed MAC blocks
- 8 × 8 multiply (sign & unsigned)
- 16-bit carry add

Advanced Clock Network

- Nine Global Clock Networks consisting of:
 - one dedicated
 - eight programmable
- Eight I/O (high drive) networks: two I/Os per bank
- Ten Quad-Net Networks—five per quadrant

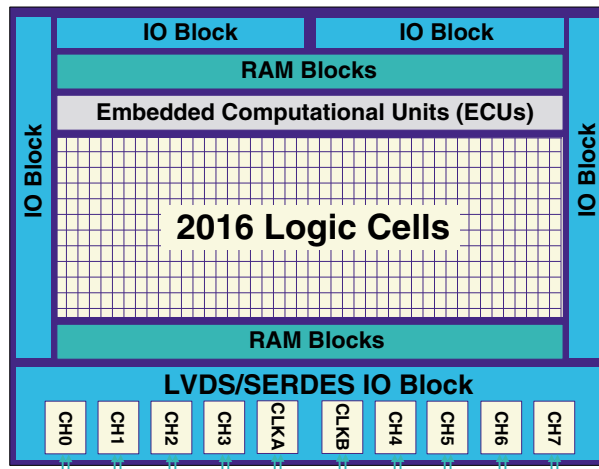

Figure 1: QL82SD Device Block Diagram

Table 1: QL82SD Device Table

Customer Part #	SERDES Data	LVDS Clocks	SRAM Blocks	Logic Cells	ECU Blocks	Programmable I/O
QL82SD-PQ208	4	2	36	2016	18	75
QL82SD-PT280	8	2	36	2016	18	121
QL82SD-PS484	8	2	36	2016	18	209
QL82SD-PB516	8	2	36	2016	18	252

General Description

LVDS SERDES Transmitter and Receiver

A QuickSD LVDS SERDES device in serializer mode takes a parallel data bus and a separate clock and converts them into a serial data stream. In deserializer mode, it takes a serial data stream and converts it to a configurable bit wide parallel data bus and separate clock. The reduced number of I/O board traces and cable connectors saves on cost and significantly simplifies design. Skew and timing issues are significantly reduced and performance is enhanced. **Figure 2** and **Figure 3** illustrate the block diagrams of the QuickSD device transmitter and receiver.

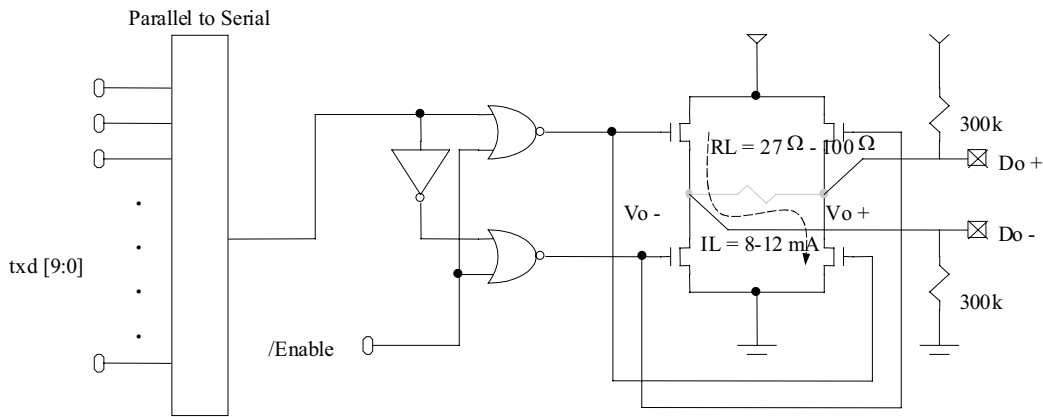

Figure 2: LVDS SERDES Transmitter Block Diagram

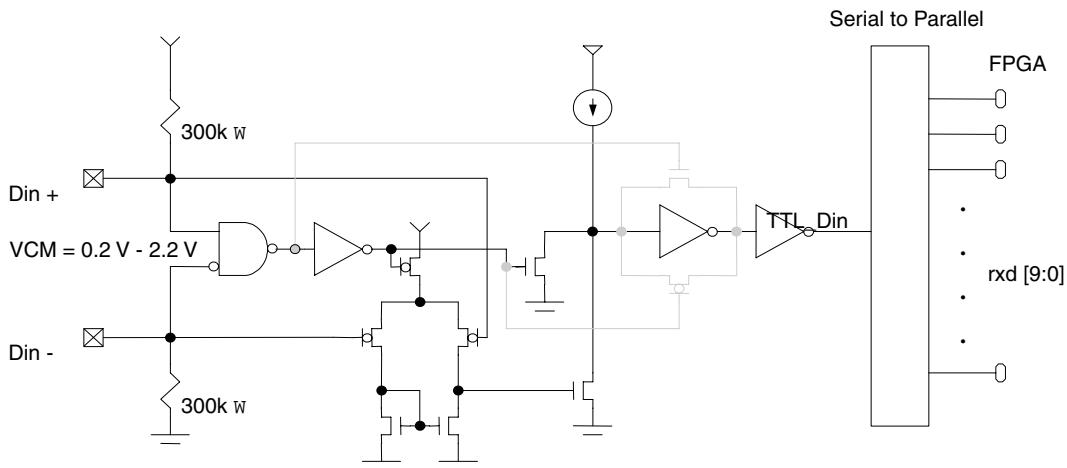

Figure 3: LVDS SERDES Receiver Block Diagram

LVDS SERDES Applications

The QuickSD device is designed to address the need for high-speed serial communications. It maintains the features of standard discrete SERDES devices, but integrates these features with customizable logic to allow for the highest degree of flexibility, performance, and integration at the lowest cost. The QuickSD device is designed to support both transmit and receive requirements in a single chip. The device can support multiple channels in a variety of modes (with or without clock recovery,) a variety of translation widths (1:1 to 1:10), as well as a range of frequencies. These capabilities make this device ideal in applications where the performance is critical and customization is required.

The QuickSD device targets three applications: on-board, board-to-board (via common backplane), and box-to-box (via common cable).

Software Support

The turnkey QuickWorks[®] package from QuickLogic[®] provides the most complete ESP and FPGA software solution from design entry to logic synthesis, to place and route, and to simulation. The package provides a solution for designers who use third-party tools from Cadence, Mentor, OrCAD, Synopsys, Viewlogic, Veribest and other third-party tools for design entry, synthesis, or simulation. A power calculator is also provided for SERDES power consumption.

To speed up the QuickSD design process, QuickLogic includes a SERDES Wizard in its QuickWorks package. This wizard simplifies the process of configuring the multi-channel SERDES core into each of its modes. For details on the SERDES Wizard, please refer to "The QL82SD Quickstart Design Guide". To find this guide go to the QuickSD device documentation Web page at

<http://www.quicklogic.com/home.asp?PageID=315&sMenuID=199#Order>.

Process Data

QuickSD is fabricated on a 0.25 μ m, five-layer metal CMOS process. The core voltage is 2.5 Volt V_{CC} supply and 3.3 V tolerant I/O with the addition of 3.3 Volt V_{CCIO} . QuickSD is available in commercial and industrial temperature grades.

Ordering Information

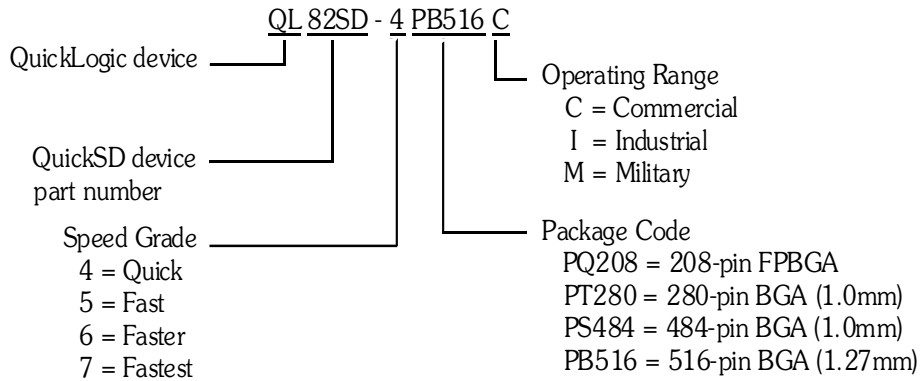

Maximum Ratings and Operating Range

Table 2: Absolute Maximum Electrical Ratings

V_{CC} Voltage	-0.3 V to 4 V	Bus LVDS Driver Output Voltage	-0.3 V to +2.8 V
LVC MOS/LVTTL Input Voltage	-0.3 V to (V _{CC} + 0.3 V)	Bus LVDS Output Short Circuit Duration	10 mS
LVC MOS/LVTTL Output Voltage	-0.3 V to (V _{CC} + 0.3 V)	ESD Rating	HBM 2 kV
Bus LVDS Receiver Input Voltage	-0.3 V to +2.8 V		

Table 3: Absolute Maximum Thermal Ratings

Junction Temperature	+150°C	Lead Temperature (Soldering, 4 seconds)	+260°C
Storage Temperature	-65°C to +150°C	Thermal and Power Dissipation Characteristics	See the following table

Table 4: Thermal and Power Dissipation Characteristics

Package	θ _{ja} (*C/W vs. Airflow)				θ _{jc} (*C/W)	Estimated Maximum Power Dissipation (W)
	0.0	0.5	1.0	2.0		
PQ208	26.0	24.5	23.0	22.0	11.0	1.65

Table 4: Thermal and Power Dissipation Characteristics

Package	θ_{ja} (*C/W vs. Airflow)				θ_{jc} (*C/W)	Estimated Maximum Power Dissipation (W)
	0.0	0.5	1.0	2.0		
PT280	18.5	17.0	15.5	14.0	7.0	2.24
PS484	28.0	26.0	25.0	23.0	9.0	2.42
PB516	20.0	19.0	17.5	16.0	7.0	2.51

Table 5: Operating Ranges

Symbol	Parameter	Industrial		Commercial		Unit	
		Min	Max	Min	Max		
Vcc	Supply Voltage	2.3	2.7	2.3	2.7	V	
Vccio	I/O Input Tolerance Voltage	2.3	3.6	2.3	3.6	V	
T _A	Ambient Temperature	-40	85	0	70	°C	
K	Delay Factor	-4 Speed Grade	0.43	2.16	0.47	2.11	n/a
		-5 Speed Grade	0.43	1.80	0.46	1.76	n/a
		-6 Speed Grade	0.43	1.26	0.46	1.23	n/a
		-7 Speed Grade	0.43	1.14	0.46	1.11	n/a

Electrical Specifications - LVDS SERDES

LVDS SERDES Transceiver Capability (Speed)

General Test Conditions

All tests are done for the 484-pin BGA package (1.00 mm pitch). The tests are set up so that an LVDS SERDES channel of a QL82SD transmits, and the other LVDS SERDES channel of the same device (or another QL82SD device) receives. All results are given as worst cases over commercial temperature, VCC, and process, with PLLVCC = 2.5 V unless otherwise specified.

If the QL82SD device is used only for transmit or receive, but not both simultaneously, the performance can be significantly better, and, in many cases, exceeds 1 Gb/s per channel.

NOTE: All data are in Mb/s. Low/High frequency refers to internal SERDES PLL lock range (see [Table 29 on page 31](#) for more information).

Cable - Normal Operation

Table 6: Cable - Normal

Modes	Low Frequency		High Frequency	
	Min	Max	Min	Max
10:1	Mode Not Available		250	350
8:1	112	360	224	368
7:1	112	322	224	364
4:1	112	348	224	304

NOTE: Test Conditions: Up to 3-meter Category 5 Cable without any compensation.

Cable - High Speed Operation

Table 7: Cable - High Speed Operation

Modes	Low Frequency		High Frequency	
	Min	Max	Min	Max
10:1	Mode Not Available		250	350
8:1	112	480	224	552
7:1	112	462	224	504
4:1	112	456	224	500

NOTE: Test Conditions: Up to 9" Category 5 Cable, and reference design in the programmable fabric portion of the device for internal skew compensation for channel link modes.

Backplane - Normal Operation

Table 8: Backplane - Normal Operation

Modes	Low Frequency		High Frequency	
	Min	Max	Min	Max
10:1	Mode Not Available		250	350
8:1	112	320	224	376
7:1	112	315	224	385
4:1	112	384	224	384

NOTE: Test Conditions: Up to 18" point-to-point backplane without any compensation.

Backplane - High Speed Operation

Table 9: Backplane - High Speed Operation

Modes	Low Frequency		High Frequency	
	Min	Max	Min	Max
10:1	Mode Not Available		250	350
8:1	112	632	224	632
7:1	112	630	224	630
4:1	112	628	224	628

NOTE: Test Conditions: Up to 18" point-to-point backplane, and reference design in the programmable fabric portion of the device for internal skew compensation for channel link modes.

1:1 Mode (Asynchronous Level Conversion)

Up to 9" cable: 0 to 500 Mbps

Up to 18" point-to-point backplane: 0 to 700 Mbps

All numbers are for LVDS channel performance only, and do not include the programmable fabric's ability to support high data rates.

Bus LVDS DC Specifications

Over the operating range, $RxV_{CC} = 3.0\text{ V to }3.6\text{ V}$.

NOTE: Apply to pad_ChX_p/n, pad_ClkX_p/n

Table 10: Serializer / Transmitter

Symbol	Parameter	Conditions	Min	Typ	Max	Units
V_{OD}	Output Differential Voltage, pad_ChX_p - Pad_ChX_n	Figure 4 Figure 5 $R_L = 27\Omega$	240	325	420	mV
V_{OS}	Offset Voltage		0.90	1.10	1.30	V
I_{OS}	Output Short Circuit Current	$D_O = 0\text{ V}$, $D_{IN} + H$, $EN + OE + V_{CC}$	20	25	35	mA
I_{OZ}	Tri-State Output Current	$D_O = 0\text{ V}/V_{CC}$, $EN = 0$	-25	± 10	25	μA
I_{OX}	Power-Off Output Current	$V_{CC} - 0\text{ V}$, $D_O = 0\text{ V}/V_{CC}$	-25	± 10	25	μA

Table 11: Deserializer / Receiver

Symbol	Parameter	Conditions	Min	Typ	Max	Units
V_{TH}	Differential Threshold High Voltage	Figure 6 $V_{CM} = 1.1\text{ V}$	n/a	35	50	mV
V_{TL}	Differential Threshold Low Voltage		-50	-35	n/a	mV
I_{IN}	Input Current	$V_{IN} = 0\text{ V}$, $V_{CC} = 0\text{ V} / 3.6\text{ V}$	-25	± 8	25	μA
		$V_{IN} = 2.4\text{ V}$, $V_{CC} = 0\text{ V} / 3.6\text{ V}$	-25	± 8	25	μA

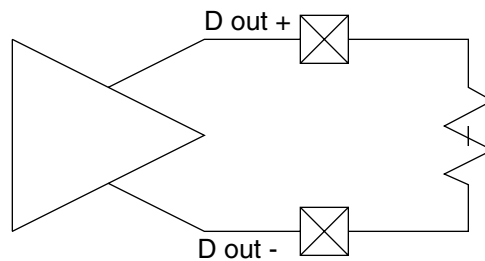

Figure 4: Output Differential Voltage

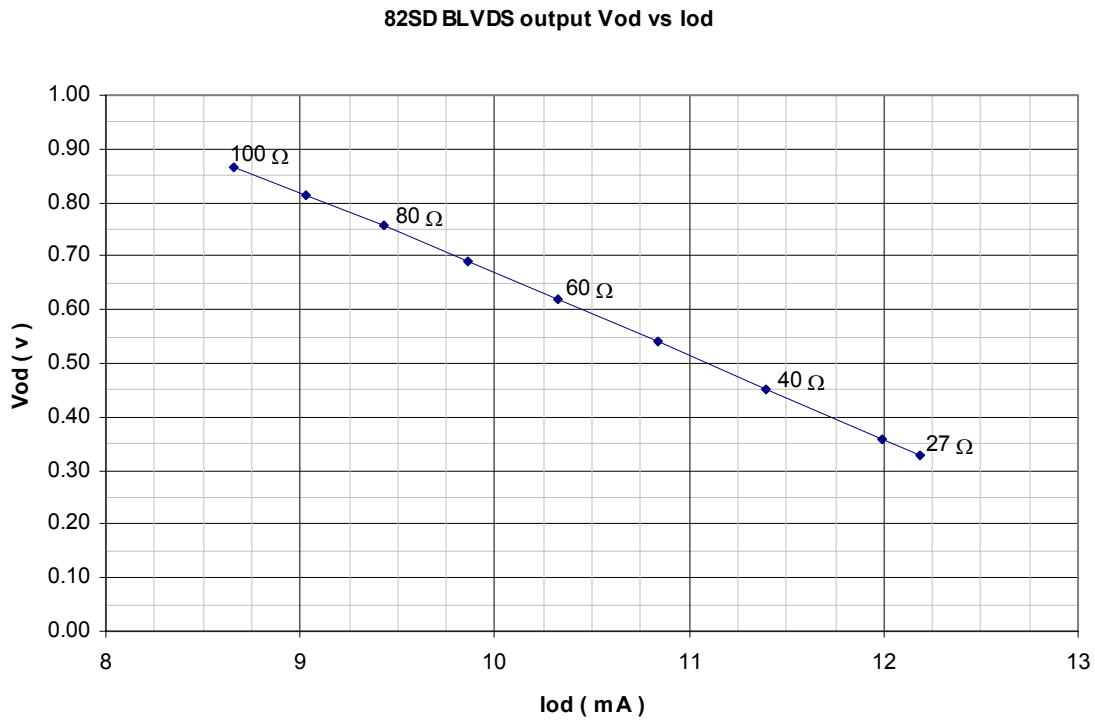

Figure 5: Output Differential Voltage for Different Loads

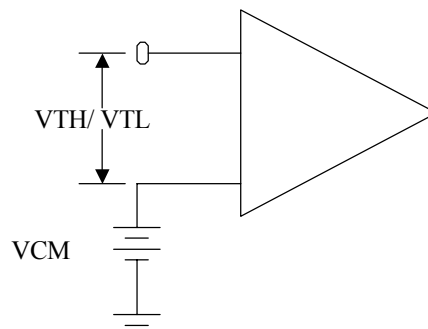

Figure 6: Differential Threshold Voltages

Supply Current per Channel

Table 12: Serializer / Transmitter

Symbol	Parameter		Conditions		Min	Typ	Max	Units
I _{CC} T	Serializer Supply Current	CL = 10 pF	Figure 7	1:1 Mode		Figure 7		mA
			Figure 8	4:1 Mode		Figure 8		mA
			Figure 9	7:1 Mode		Figure 9		mA
			Figure 12	8:1 Mode		Figure 12		mA
			Figure 11	10:1 Mode Data/Clock		Figure 11		mA
I _{CC} TX	Serializer Supply Current Powerdown		EN = 0			1	10	μA

Table 13: Deserializer / Receiver

Symbol	Parameter		Conditions		Min	Typ	Max	Units
I _{CC} R	Serializer Supply Current	CL = 10 pF	Figure 13	1:1 Mode		Figure 13		mA
			Figure 14	4:1 Mode		Figure 14		mA
			Figure 15	7:1 Mode		Figure 15		mA
			Figure 13	8:1 Mode		Figure 13		mA
			Figure 14	10:1 Mode Data/Clock		Figure 14		mA
I _{CC} RX	Serializer Supply Current Powerdown		EN = 0			1	10	μA

NOTE: More accurate supply current/power consumption numbers specific to your application should be calculated using the power calculator supplied with QuickLogic's QuickWorks software package.

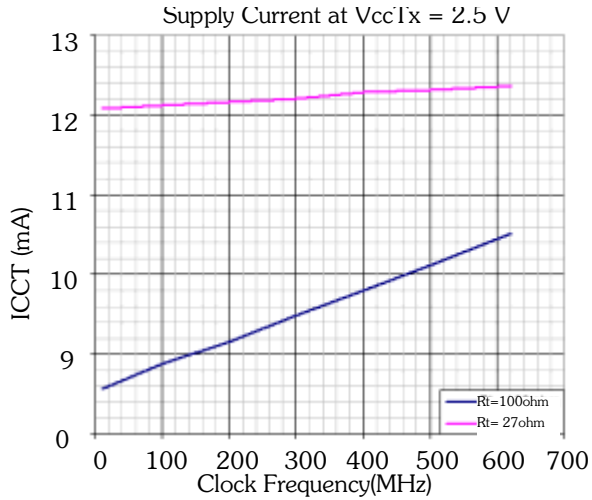

Figure 7: Data/Clock Channel, 1:1 Transmit Mode

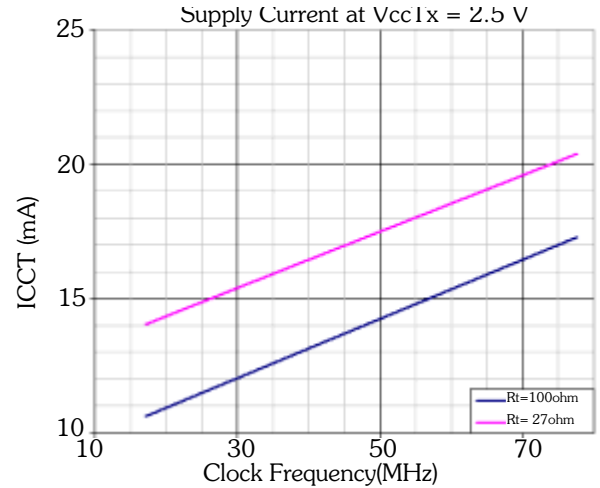

Figure 10: Data/Clock Channel, 8:1 Transmit Mode

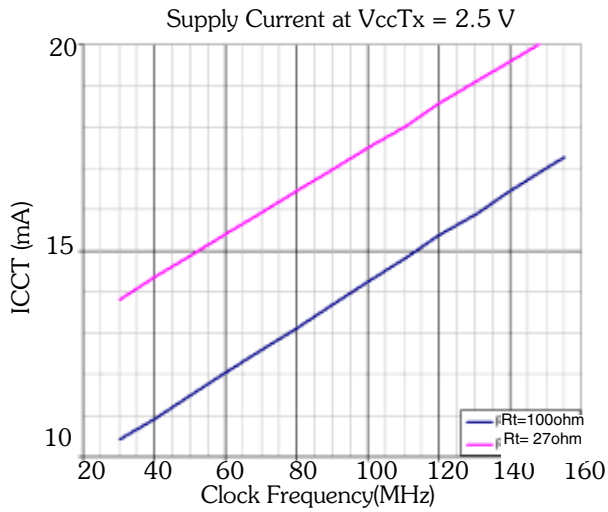

Figure 8: Data/Clock Channel, 4:1 Transmit Mode

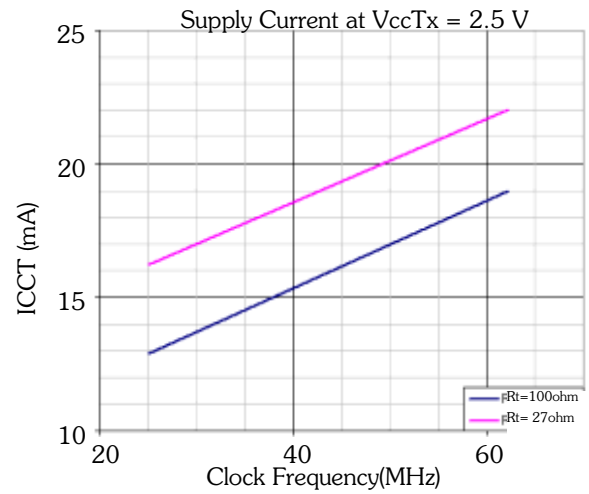

Figure 11: Data/Clock Channel, 10:1 Transmit Mode

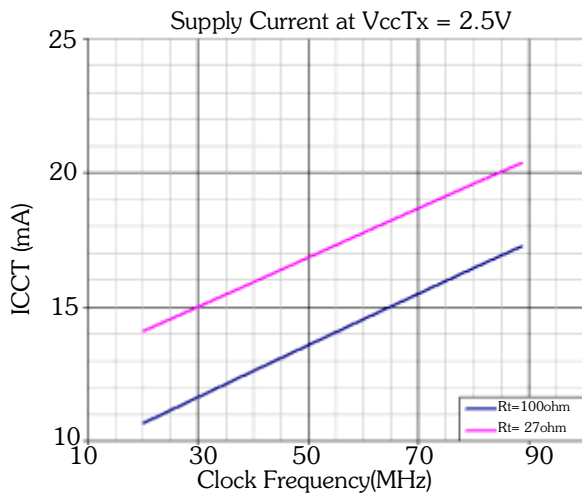

Figure 9: Data/Clock Channel, 7:1 Transmit Mode

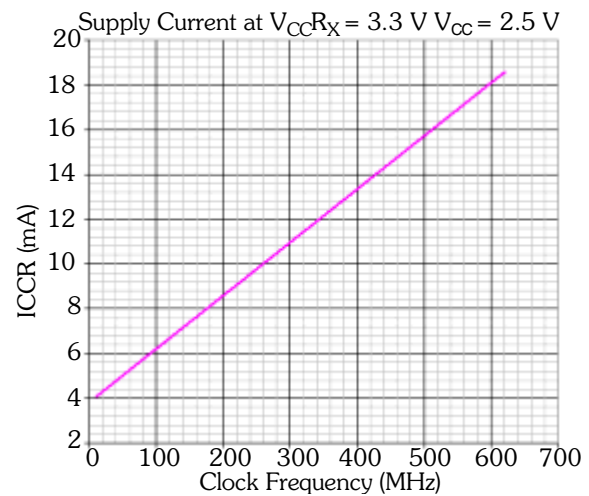

Figure 12: Data/Clock Channel, 1:1 Receive Mode

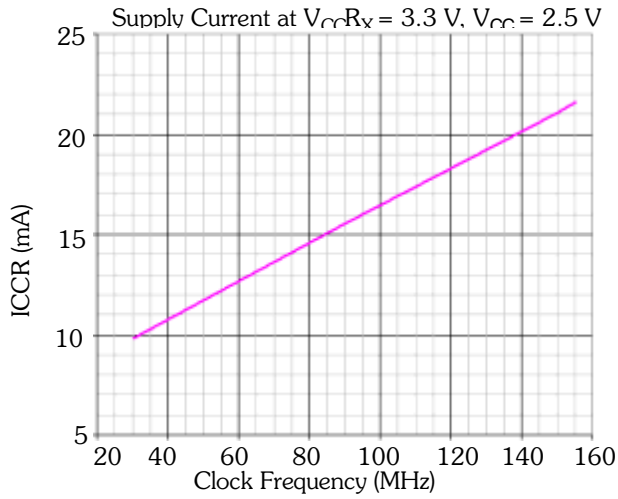

Figure 13: Data/Clock Channel, 4:1 Receive Mode

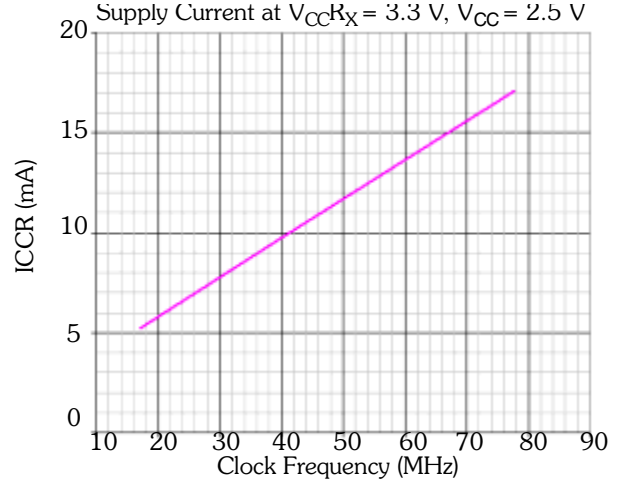

Figure 15: Data/Clock Channel, 8:1 Receive Mode

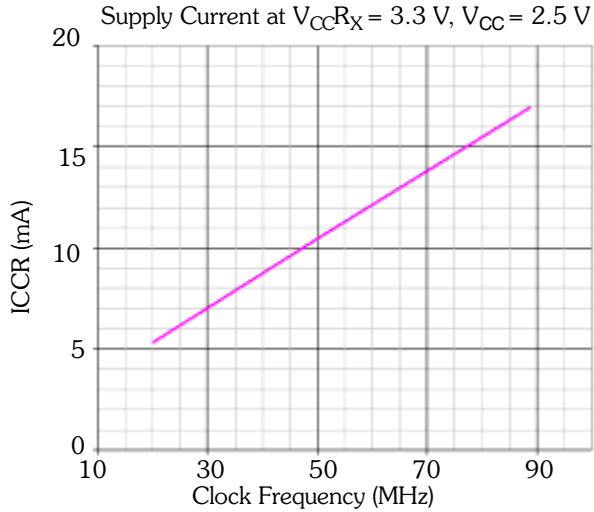

Figure 14: Data/Clock Channel, 7:1 Receive Mode

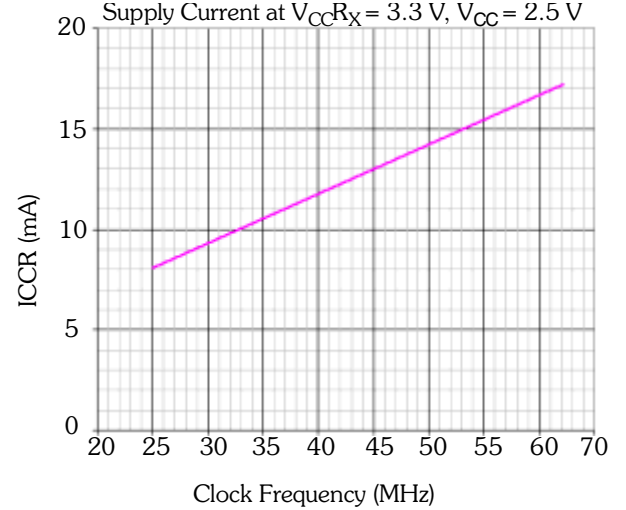

Figure 16: Data/Clock Channel, 10:1 Receive Mode

SERDES Timing Requirements

NOTE: Both **Table 14** and **Table 15** refer to CDR (10:1) Mode for ChX_txclk and Channel Link (8:1, 7:1, 4:1) Mode for ClkX_txclk

Table 14: Serializer / Transmitter Transmit Clock

Symbol	Parameter	Conditions	Min	Typ	Max	Units
t_{TCP}	Transmit Clock Period	Mode Dependent	n/a	T	n/a	nS
t_{TDC}	Transmit Clock Duty Cycle		45	50	55	%
t_{CLKT}	Transmit Clock Input Transition Time	Figure 17	1	n/a	n/a	V/nS
t_{JIT}	Transmit Clock Input Jitter		n/a	n/a	150.0	pS (RMS)

Table 15: Deserializer / Receiver Transmit Clock

Symbol	Parameter	Conditions	Min	Typ	Max	Units
t_{RCP}	Reference Clock Period	Mode Dependent	n/a	T	n/a	nS
t_{RFDC}	Reference Clock Duty Cycle		40	50	60	%
t_{RFCP}/t_{TCP}	Ratio of Reference Clock to Transmit Clock		0.4	0.5	0.6	n/a
t_{RFTT}	Reference Clock Transition Time	Figure 17	1	n/a	n/a	V/nS

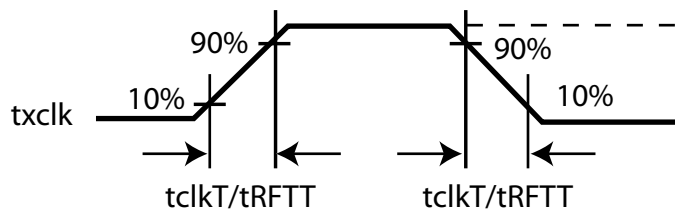

Figure 17: Serializer Transmit Clock / Deserializer Reference Clock Transition Times

SERDES Switching Characteristics - Serializer/Transmitter]

Table 16: Serializer/Transmitter Switching Characteristics

CDR (10:1) Mode							
Symbol	Parameter	Conditions	Min	Typ	Max	Units	
t _{HZD}	pad_ChX_p/n High to Tri-State Delay	Figure 18	1.9	2.2	2.5	nS	
t _{LZD}	pad_ChX_p/n Low to Tri-State Delay		1.9	2.0	2.2	nS	
t _{ZHD}	pad_ChX_p/n Tri-State to High Delay		1.9	2.4	3.0	nS	
t _{ZLD}	pad_ChX_p/n Tri-State to Low Delay		2.0	2.3	2.8	nS	
t _{DIS}	ChX_txd[9:0] Setup to ChX_txclk	Figure 19	2.6		3.2	nS	
t _{DIH}	ChX_txd[9:0] Hold from ChX_txclk		2.1		2.7	nS	
t _{PLD}	Serializer PLL Lock Time	Figure 20			90	uS	
Channel Link (8:1, 7:1, 4:1) Mode							
Symbol	Parameter	Conditions	Min	Typ	Max	Units	
t _{HZD}	pad_ChX_p/n High to Tri-State Delay	Figure 18	1.9	2.2	2.5	nS	
t _{LZD}	pad_ChX_p/n Low to Tri-State Delay		1.9	2.0	2.2	nS	
t _{ZHD}	pad_ChX_p/n Tri-State to High Delay		1.9	2.4	3.0	nS	
t _{ZLD}	pad_ChX_p/n Tri-State to Low Delay		2.0	2.3	2.8	nS	
t _{DIS}	ChX_txd[N-1:0] Setup to ChX_txclk	Figure 21	2.6		3.2	nS	
t _{DIH}	ChX_txd[N-1:0] Hold from ChX_txclk		2.1		2.7	nS	
t _{SD}	Serializer Delay				1.7	nS	
t _{SCP}	Serial Transmit Clock Period				T/mode	nS	
t _{TXD[N-1]}	Transmitter Output Pulse Position for Bit [N-1]			[N-1] x t _{SCP} + 1.1		[N-1] x t _{SCP} + 1.5	nS
t _{PLD}	Serializer PLL Lock Time		Figure 20			90	uS
Asynchronous Level Conversion (1:1) Mode							
t _{HZD}	pad_ChX_p/n High to Tri-State Delay	Figure 18	1.9	2.2	2.5	nS	
t _{LZD}	pad_ChX_p/n Low to Tri-State Delay		1.9	2.0	2.2	nS	
t _{ZHD}	pad_ChX_p/n Tri-State to High Delay		1.9	2.4	3.0	nS	
t _{ZLD}	pad_ChX_p/n Tri-State to Low Delay		2.0	2.3	2.8	nS	
t _{ASD}	Asynchronous Serializer Delay - Data Channel	Figure 22			1.8	nS	
t _{ASC}	Asynchronous Serializer Delay - Channel Clock				1.7	nS	

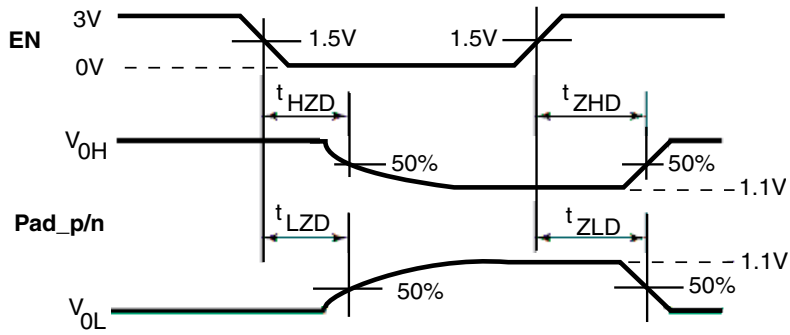

Figure 18: Serializer Delays to Tri-State

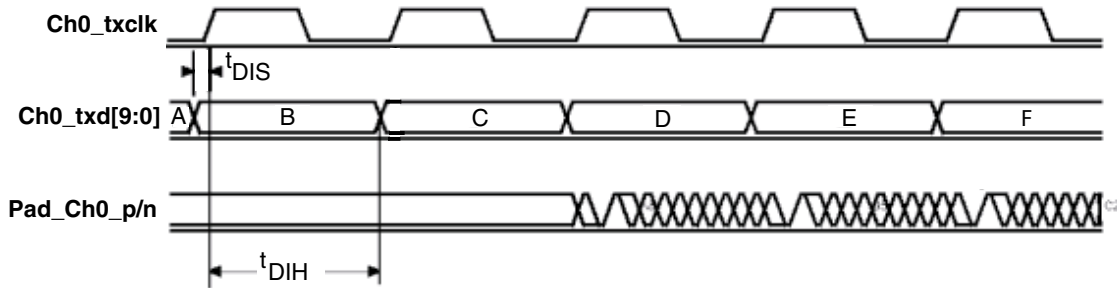

Figure 19: 10:1 Mode Serializer Transmit with Embedded Clock

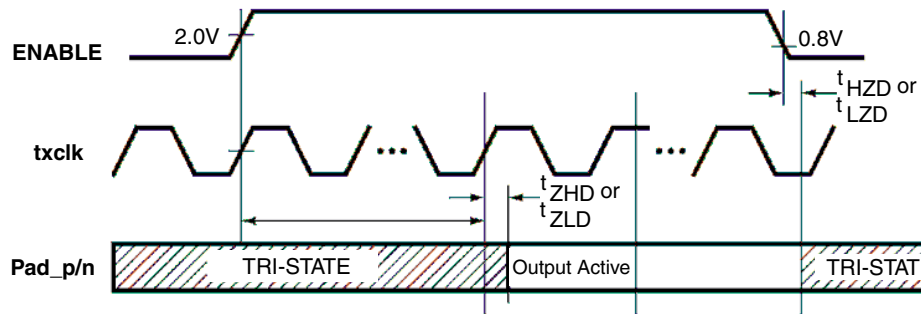

Figure 20: Serializer PLL Times

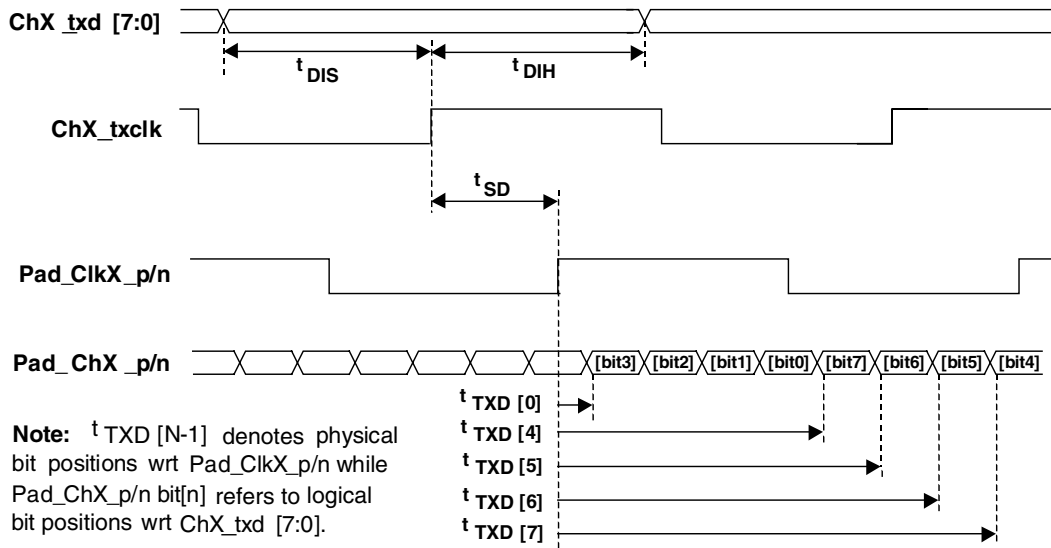

Figure 21: Channel Link Mode Serializer Transmit (Using 8:1 Mode as Example)

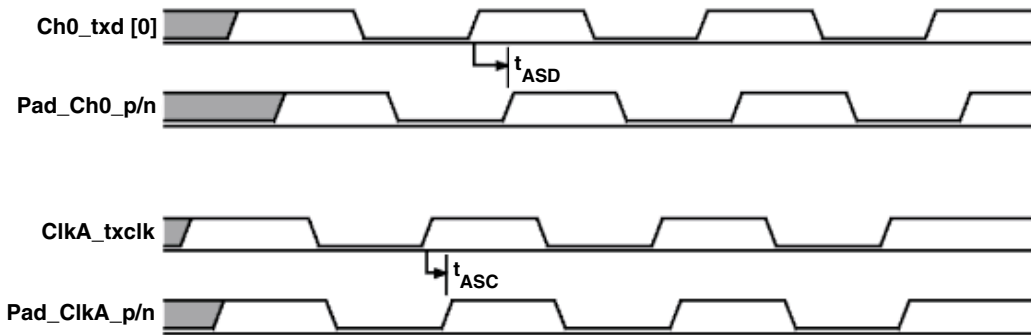

Figure 22: 1:1 Mode Asynchronous Level Conversion Mode Serializer Delays

SERDES Switching Characteristics - Deserializer/Receiver

Table 17: Deserializer / Receiver Switch Characteristics

CDR (10:1) Mode							
Symbol	Parameter	Conditions	Min	Typ	Max	Units	
t_{RCP}	ChX_rxclk Period		28.5	T	40.0	nS	
t_{RDC}	ChX_rxclk Duty Cycle		45	50	55	%	
t_{DD}	Deserializer Delay	Figure 23	$2 \times t_{RCP} + 1.5$	$2 \times t_{RCP} + 2.5$	$2 \times t_{RCP} + 3.5$	nS	
t_{RXPd}	ChX_rxclk to ChX_rxd[9..0]		1.5	2.5	3.5	nS	
t_{DSR1}	Deserializer PLL Lock Time from powered-down state	Figure 24: 25 MHz Figure 24: 50 MHz		5 8		uS uS	
t_{DSR2}	Deserializer PLL Lock Time from SYNCPAT	Figure : 25 MHz Figure : 50 MHz		1 0.75		uS uS	
t_{DJIT}	Pad_ChX_p/n Jitter	25 MHz 50 MHz		± 350 ± 200		pS pS	
Channel Link (8:1, 7:1, 4:1) Mode							
Symbol	Parameter	Conditions	Min	Typ	Max	Units	
t_{RCP}	ChX_rxclk Period		Mode Dependent $\left[\frac{\text{LVDS Link Frequency}}{\text{Compression Mode}} \right]^{-1}$	T	Mode Dependent $\left[\frac{\text{LVDS Link Frequency}}{\text{Compression Mode}} \right]^{-1}$	nS	
t_{RDC}	ChX_rxclk Duty Cycle		45	50	55	%	
t_{DD}	Deserializer Delay	Figure 26	$2 \times t_{RCP} + 1.5$	$2 \times t_{RCP} + 2.5$	$2 \times t_{RCP} + 3.5$	nS	
t_{RXPd}	ChX_rxclk to ChX_rxd[N-1..0]		1.5	2.5	3.5	nS	
t_{RXDS}	Pad_ChX_p/n Setup to Strobe Position				150	200	pS
t_{RXDH}	Pad_ChX_p/n Hold to Strobe Position				150	200	pS
t_{SCD}	Pad_ClkX_p/n to Serial Clock Delay ^a			0.6	0.8	1	nS
t_{SCP}	Serial Clock Period				T/mode		nS
$t_{RXD[N-1]}$	Receiver Input Strobe Position for Bit [N-1]			$[N-1] \times t_{SCP} + 1.1$		$[N-1] \times t_{SCP} + 2.4$	nS
t_{DSR1}	Deserializer PLL Lock Time from powered-down state		Figure 24: 25 MHz Figure 24: 50 MHz		5 8		uS uS
t_{DJIT}	Pad_ChX_p/n Jitter	25 MHz 50 MHz		± 300 ± 150		pS pS	
Asynchronous Level Conversion (1:1) Mode							
t_{ADD}	Asynchronous Deserializer Delay - Data Channel	Figure 27			1.7	nS	
t_{ADC}	Asynchronous Serializer Delay - Channel Clock ^a		0.6	0.8	1	nS	

a. These values include the delay resulting from application of internal compensation for data/clock skew.

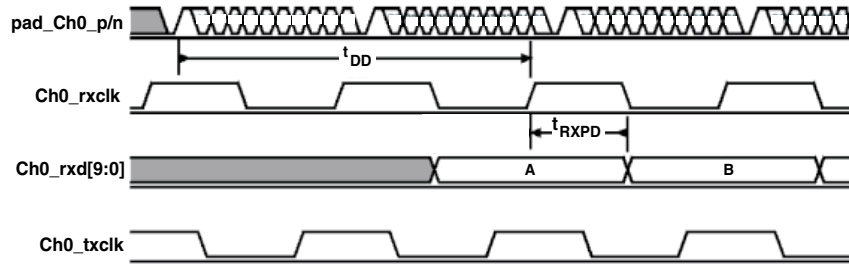

Figure 23: 10:1 Mode Deserializer Receive with Embedded Clock

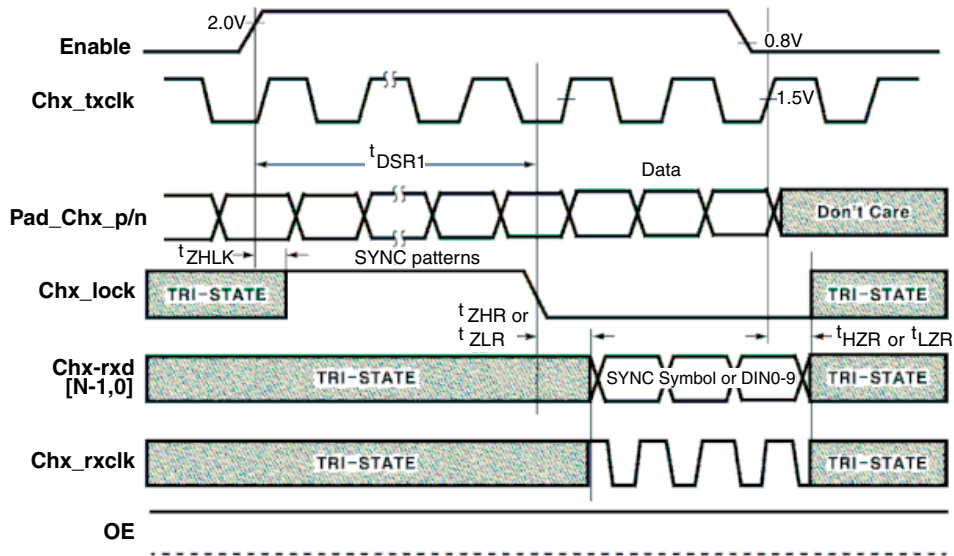

Figure 24: Deserializer PLL Lock Time from Power Down

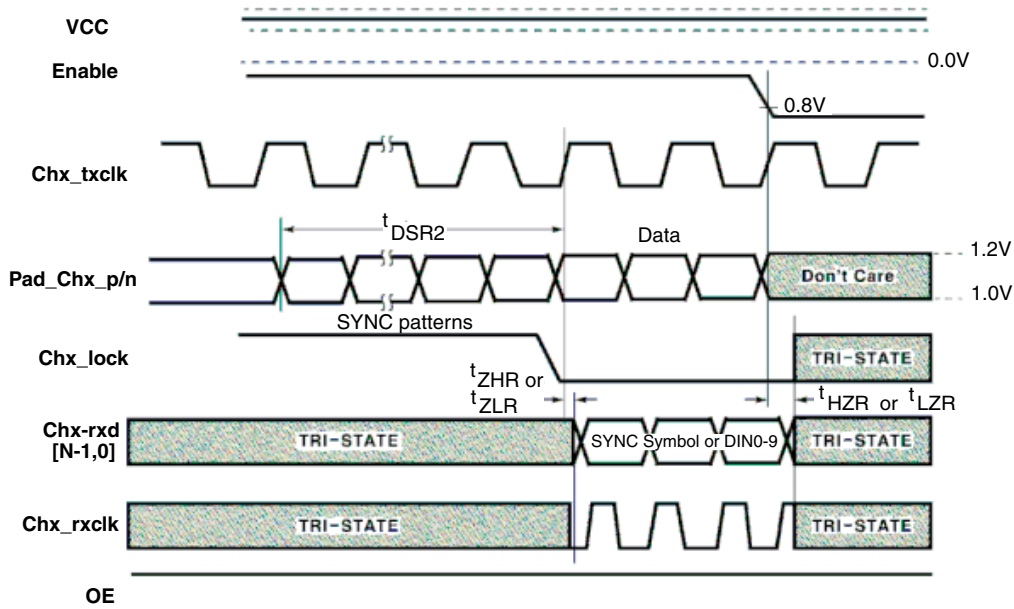

Figure 25: 10:1 Mode Deserializer PLL Lock Time from SYNC PAT

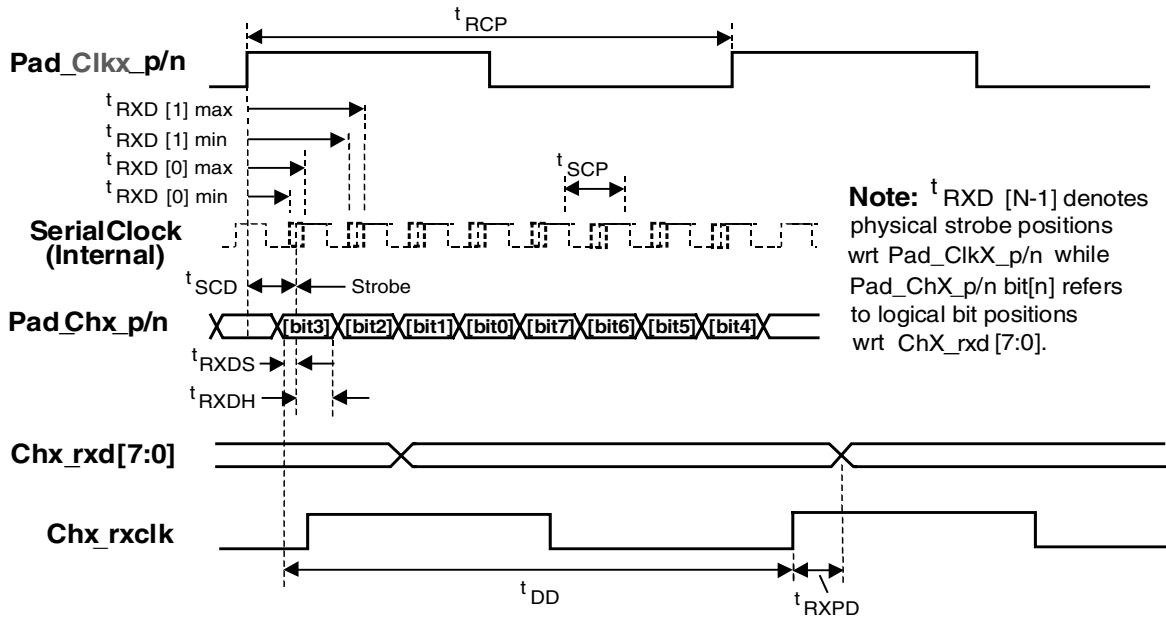

Figure 26: Channel Link Mode Deserializer Receive (Using 8:1 Mode as Example)

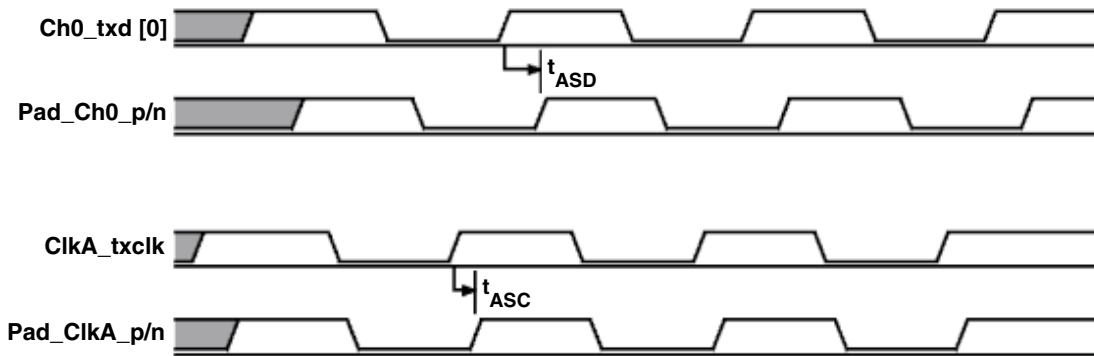

Figure 27: 1:1 Mode Asynchronous Level Conversion Mode Deserializer Delays

SERDES Bit Error Rate

The following table indicates the SERDES bit error rate at $T_A = 25^\circ \text{C}$ and $\text{PLL}V_{cc} = 2.5 \text{V}$ unless otherwise specified.

Table 18: Serializer/Deserializer Bit Error Rate

Modes	Bit Error Rate
10:1	$< 1 \times 10^{-12}$
8:1	$< 1 \times 10^{-12}$
7:1	$< 1 \times 10^{-12}$
4:1	$< 1 \times 10^{-12}$

Electrical Specification - Programmable Fabric

DC Characteristics

Table 19: DC Characteristics

Symbol	Parameter	Conditions	Min	Max	Units
I_I	I or I/O Input Leakage Current	$V_I = V_{CCIO}$ or GND	-10	10	μA
I_{OZ}	3-State Output Leakage Current	$V_I = V_{CCIO}$ or GND	-10	10	μA
C_I	Input Capacitance ^a			8	pF
I_{OS}	Output Short Circuit Current ^b	$V_o = GND$	-15	-180	mA
		$V_o = V_{CC}$	40	210	mA
I_{CC}	D.C. Supply Current ^c	$V_I, V_o = V_{CCIO}$ or GND	0.50 (typ)	2	mA
I_{CCIO}	D.C. Supply Current on V_{CCIO}		0	2	mA
I_{REF}	D.C. Supply Current on V_{REF}		-10	10	μA
I_{PD}	Pad Pull-down (programmable)	$V_{CCIO} = 3.6 V$		150	μA

- a. Capacitance is sample tested only. Clock pins are 12 pF maximum.
- b. Only one output at a time. Duration should not exceed 30 seconds.
- c. For -4/-5/-6/-7 commercial grade devices only. Maximum ICC is 3 mA for all industrial grade devices.

DC Input/Output Levels

Table 20: DC Input/Output Levels

	V_{REF}		V_{IL}		V_{IH}		V_{OL}	V_{OH}	I_{OL} mA	I_{OH} mA
	V_{MIN}	V_{MAX}	V_{MIN}	V_{MAX}	V_{MIN}	V_{MAX}	V_{MAX}	V_{MIN}		
LVTTTL	n/a	n/a	-0.3	0.8	2.0	$V_{CCIO} - 0.3$	0.40	2.40	2.0	-2.0
LVC MOS2	n/a	n/a	-0.3	0.7	1.7	$V_{CCIO} - 0.3$	0.70	1.70	2.0	-2.0
GTL+	0.88	1.12	-0.3	$V_{REF} - 2.0$	$V_{REF} + 2.0$	$V_{CCIO} - 0.3$	0.60	n/a	40	n/a
PCI	n/a	n/a	-0.3	$0.30 \times V_{CC}$	$0.50 \times V_{CC}$	$V_{CCIO} - 0.5$	$0.10 \times V_{CC}$	$0.90 \times V_{CC}$	1.5	-0.5
SSTL2	1.15	1.35	-0.3	$V_{REF} - 0.18$	$V_{REF} + 0.18$	$V_{CCIO} + 0.3$	0.74	1.76	7.6	-7.6
SSTL3	1.30	1.70	-0.3	$V_{REF} - 0.20$	$V_{REF} + 2.0$	$V_{CCIO} + 0.3$	1.10	1.90	8.0	-8.0

NOTE: The above table gives the programmable logic timing model for the QuickSD device. The programmable logic includes the following major elements: Super Logic (Flip-Flop and Combinational Circuit), Clock, and I/O.

Super Logic (Flip-Flop and Combinational Circuit) AC Characteristics at VCC = 2.5 V, TA = 25°C (K = 1)

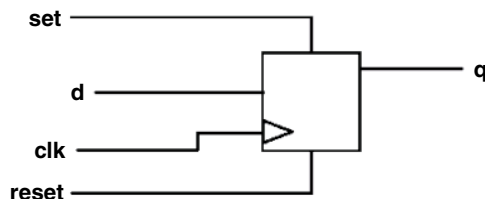

Figure 28: Super Logic Cell Flip-Flop Structure

Table 21: Logic Cells

Symbol	Parameter	Condition	Propagation delay (ns)
			Fanout = 1
t_{PD}	Combinational Delay ^a	Figure 29	0.257
t_{SU}	Setup Time ^b	Figure 30	0.22
t_H	Hold Time		0
t_{CLK}	Clock to Q Delay	Figure 31	0.255
t_{CWHI}	Clock High Time	Figure 32	0.46
t_{CWLO}	Clock Low Time		0.46
t_{SET}	Set Delay	Figure 33	0.18
t_{RESET}	Reset Delay		0.09
t_{SW}	Set Width		0.30
t_{RW}	Reset Width		0.30

- a. Stated timing for worst case Propagation Delay over process variation at VCC = 2.5 V and TA = 25°C. Multiply by the appropriate Delay Factor, K, for speed grade, voltage and temperature settings as specified in the operating range.
- b. These limits are derived from a representative selection of the slowest paths through the logic cell including typical net delays. Worst case delay values for specific paths should be determined from timing analysis of your particular design.

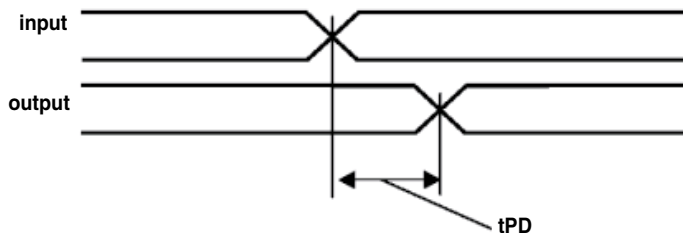

Figure 29: Combinational Delay for Logic Cell

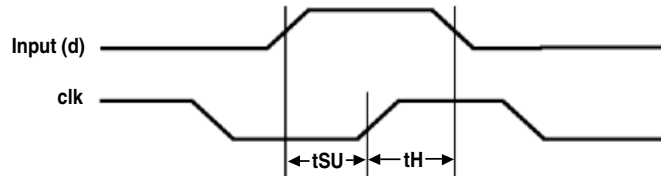

Figure 30: Setup and Hold Time for Flip-Flop

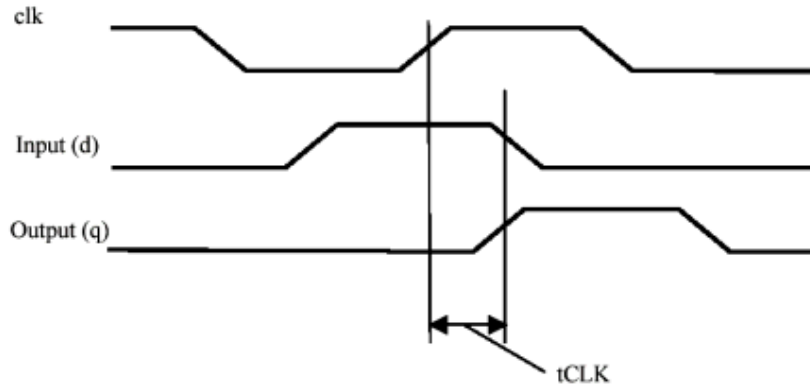

Figure 31: Delay from Clock Input to Flip-Flop Q Output

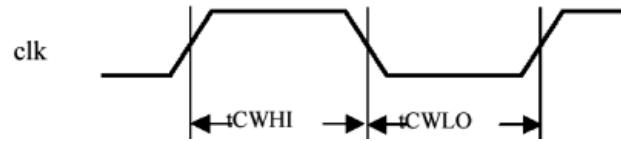

Figure 32: Clock High and Low Time for Flip-Flop

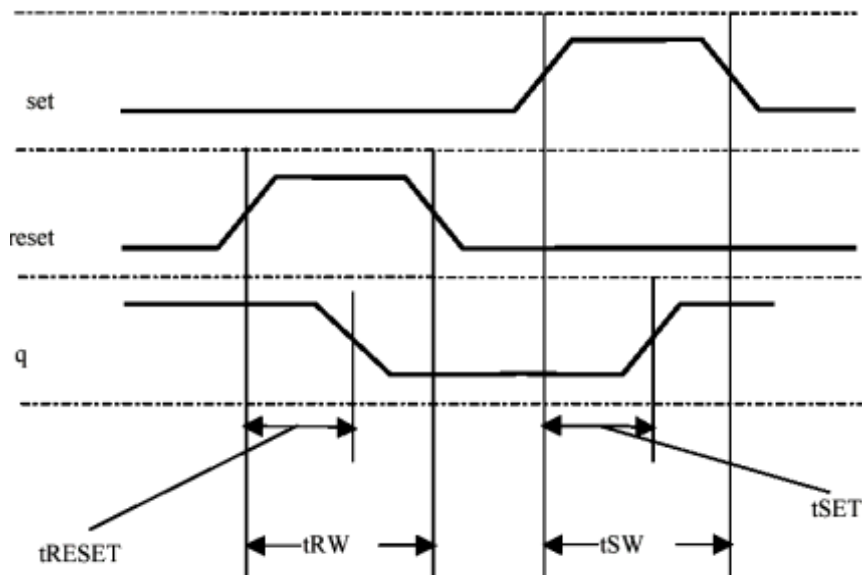

Figure 33: Timing Requirements for Flip-Flop SET and RESET

Clock AC Characteristics at VCC = 2.5 V, TA = 25 °C (K = 1)

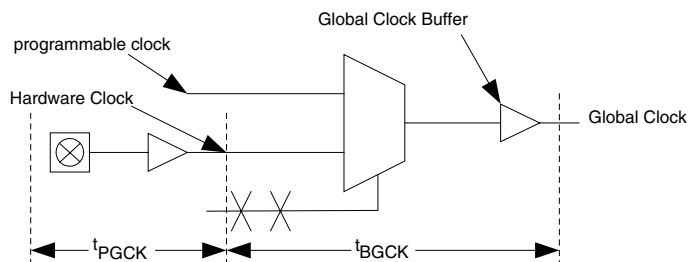

Figure 34: Clock Structure

Table 22: Clock Performance

	Clock Performance	
	Global	Dedicated
Logic Cells	1.51 ns	1.59 ns
I/Os	2.06 ns	1.73 ns
Skew	0.55 ns	0.14 ns

Table 23: Input Register Cell

Symbol Input Register Cell Only	Parameter	Propagation Delay (ns)
t_{PGCK}	Global clock pin delay to quad net	1.34
t_{BGCK}	Global clock buffer delay (quad net to flip flop)	0.56

I/O AC Characteristics at VCC = 2.5 V, TA = 25 °C (K = 1)

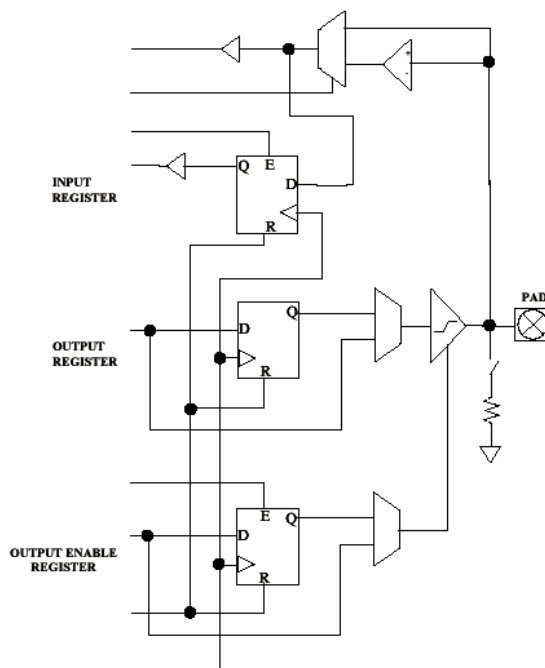

Figure 35: I/O Structure

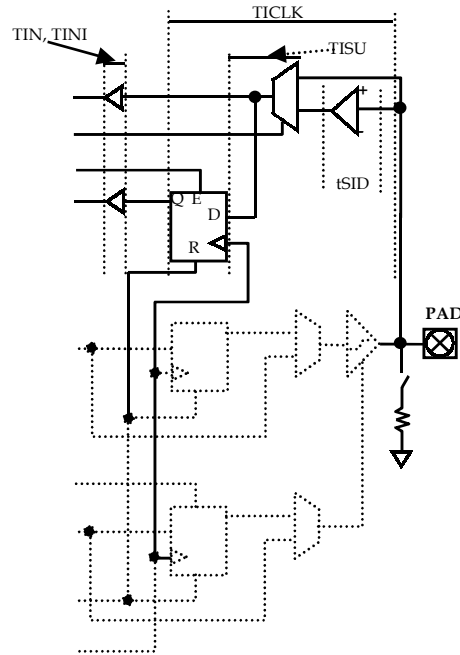

Figure 36: Input Register Cell

Table 24: Input Register Cell

Symbol	Parameter	Propagation Delay (ns)
Input Register Cell Only		
t_{SU}	Input Register Setup Time: the amount of time the synchronous input of the flip flop must be stable before the active clock edge.	3.12
t_{IH}	Input Register Hold Time: the amount of time the synchronous input of the flip flop must be stable after the active clock edge.	0
t_{CLK}	Input Register Clock to Q: the amount of time taken by the flip flop to output after the active clock edge.	1.08
t_{RST}	Input Register Reset Delay: the amount of time between when the flip flop is “reset” (low) and when Q is consequently “reset” (low).	0.99
t_{ESU}	Input Register Clock Enable Setup Time: the amount of time “enable” must be stable before the active clock edge.	0.37
t_{IEH}	Input Register Clock Enable Hold Time: the amount of time “enable” must be stable after the active clock edge.	0

Table 25: Standard Input Delays

Symbol	Parameter	Propagation delay (ns)
$t_{SID(LVTTL)}$	LVTTL input delay: Low Voltage TTL for 3.3 V applications	0.34
$t_{SID(LVCOS2)}$	LVCOS2 input delay: Low Voltage CMOS for 2.5 V and lower applications	0.42
$t_{SID(GTL+)}$	GTL+ input delay: Gunning Transceiver Logic	0.68
$t_{SID(SSTL3)}$	SSTL3 input delay: Stub Series Terminated Logic for 3.3 V	0.55
$t_{SID(SSTL2)}$	SSTL2 input delay: Stub Series Terminated Logic for 2.5V	0.607

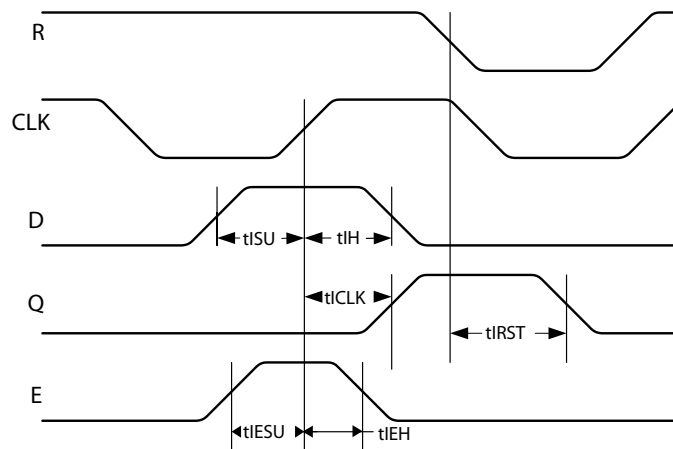

Figure 37: Input Register Timing

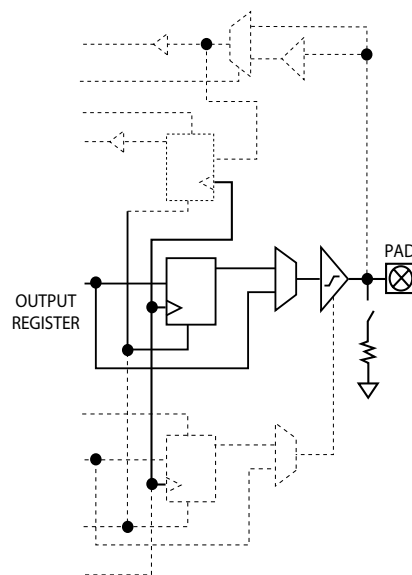

Figure 38: Output Register Cell

Table 26: Output Register Cell

Symbol	Parameter	Propagation delay (ns)
Output Register Cell Only		
t_{OUTLH}	Output Delay low to high (10% of H)	0.40
t_{OUTHHL}	Output Delay high to low (90% of H)	0.55
t_{PZH}	Output Delay tri-state to high (10% of Z)	2.94
t_{PZL}	Output Delay tri-state to low (90% of Z)	2.34
t_{PHZ}	Output Delay high to tri-State	3.07
t_{PLZ}	Output Delay low to tri-State	2.53
t_{CO}	Clock to out delay	3.15 (fast slew) 10.2(slow slew)

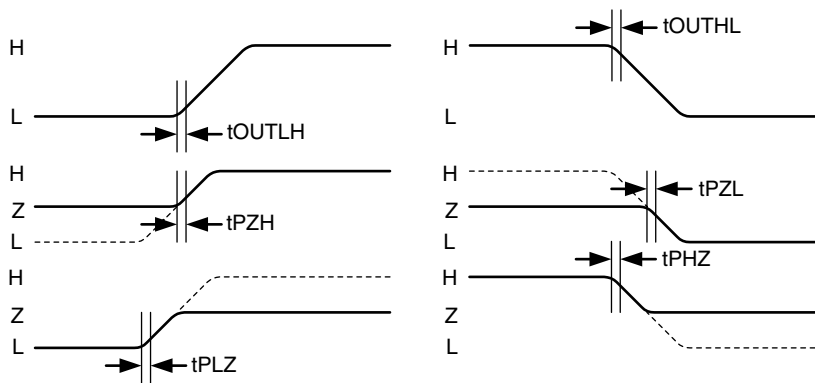

Figure 39: Output Register Cell Timing

Electrical Specification - RAM Block

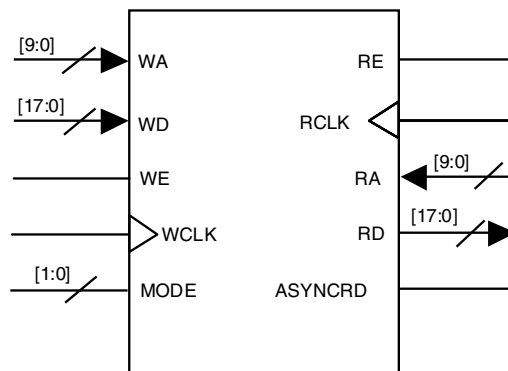

Figure 40: RAM Module

RAM Cell Synchronous Write Timing

Table 27: RAM Cell Synchronous Write Timing

Symbol	Parameter	Propagation delay (ns)
t_{SWA}	WA setup time to WCLK: the amount of time the WRITE ADDRESS must be stable before the active edge of the WRITE CLOCK	0.675
t_{HWA}	WA hold time to WCLK: the amount of time the WRITE ADDRESS must be stable after the active edge of the WRITE CLOCK	0
t_{SWD}	WD setup time to WCLK: the amount of time the WRITE DATA must be stable before the active edge of the WRITE CLOCK	0.654
t_{HWD}	WD hold time to WCLK: the amount of time the WRITE DATA must be stable after the active edge of the WRITE CLOCK	0
t_{SWE}	WE setup time to WCLK: the amount of time the WRITE ENABLE must be stable before the active edge of the WRITE CLOCK	0.623
t_{HWE}	WE hold time to WCLK: the amount of time the WRITE ENABLE must be stable after the active edge of the WRITE CLOCK	0
t_{WCRD}	WCLK to RD (WA=RA): the amount of time between the active WRITE CLOCK edge and the time when the data is available at RD	4.38

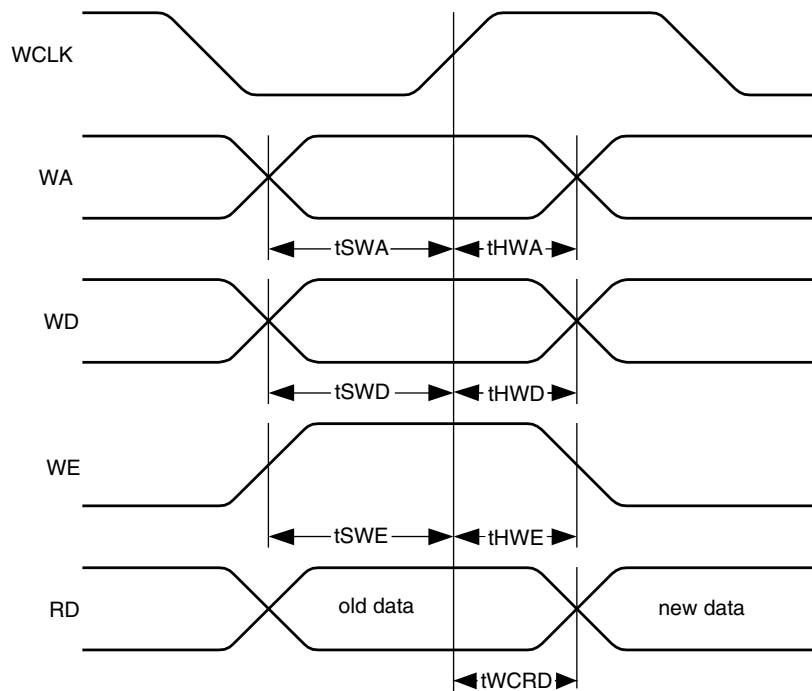

Figure 41: RAM Cell Synchronous Write Timing

RAM Cell Read Timing

Table 28: RAM Cell Synchronous and Asynchronous Read Timing

Symbol	Parameter	Propagation delay (ns)
RAM Cell Synchronous Read Timing		
t_{SRA}	RA setup time to RCLK: the amount of time the READ ADDRESS must be stable before the active edge of the READ CLOCK	0.686
t_{HRA}	RA hold time to RCLK: the amount of time the READ ADDRESS must be stable after the active edge of the READ CLOCK	0
t_{SRE}	RE setup time to WCLK: the amount of time the READ ENABLE must be stable before the active edge of the READ CLOCK	0.243
t_{HRE}	RE hold time to WCLK: the amount of time the READ ENABLE must be stable after the active edge of the READ CLOCK	0
t_{RCRD}	RCLK to RD: the amount of time between the active READ CLOCK edge and the time when the data is available at RD	4.38
RAM Cell Asynchronous Read Timing		
t_{PDRD}	RA to RD: amount of time between when the READ ADDRESS is input and when the DATA is output	2.06

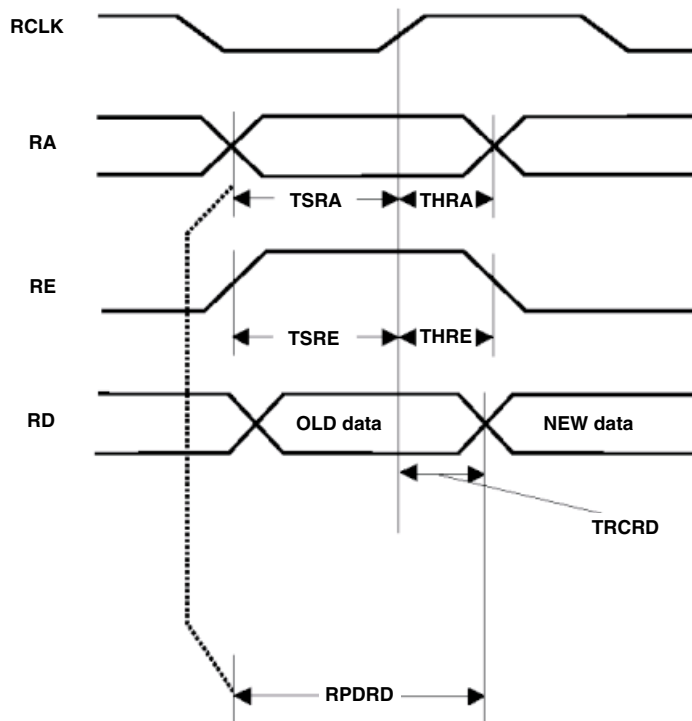

Figure 42: RAM Cell Synchronous and Asynchronous Read Timing

LVDS SERDES Description

LVDS SERDES Applications

The QL82SD device in the QuickLogic QuickSD ESP (Embedded Standard Product) device family provides a completely integrated configurable Serializer/Deserializer interface solution combined with 536 K system gates of customizable logic. This device provides a means to receive and transmit high-speed serial data and implement any proprietary high-speed serial link.

The QL82SD device is a high performance serializer/deserializer chip. It can be combined with FIFO buffer memory to build a complete serial link. The need for external FIFOs can be eliminated by configuring the available internal RAM as two 256 x 36 FIFOs.

The embedded SERDES core is a full duplex design with a serialization section for transmission and a deserialization section for reception. The transmitter and receiver can be configured for level conversion (1:1), signals that transmit a clock signal with the data (1:4, 1:7, 1:8), or applications that require clock recovery (1:10).

The embedded SERDES core has a system interface that emulates a synchronous FIFO for ease of use. FIFOs allow maximum sustained performance of 600 MB/s running a full duplex link. Their function is to handle the asynchronous interface between the bus data rate and the different serial data rates, and handle phase and frequency differences inherent in serial links. Internal FIFOs of 256 x 36 or 512 x 16 can be cascaded with external FIFOs to expand the buffering to the desired size.

The QL82SD is a versatile part that allows the system designer to create proprietary or standardized serial links by taking advantage of some, or all, of the embedded features. It has a number of useful features for system designers of proprietary links with additions of embedded computational units and customizable I/O.

LVDS SERDES Block Functional Description

The QuickSD SERDES consists of a physical layer for high-speed serial communications, handling all data translations, clocking and timing. The core is made up of eight data channels and two channel clocks. These blocks contain the circuitry necessary for all the data muxing and de-muxing, clock multiplication and division, clock and data phase alignment, and clock recovery and encoding. The core can be configured to support systems that transmit a separate clock signal or that have the clock embedded into the data stream and require clock recovery.

LVDS SERDES Data Channel Configuration

A representation of the SERDES data channel is shown in **Figure 43**. The device consists of eight identical data channels.

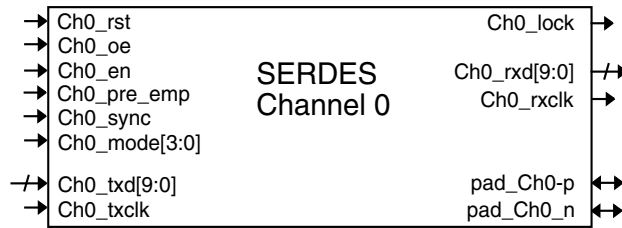

Figure 43: SERDES Channel 0

Each SERDES data channel can be operated independently. The data channels are transceivers, so they can either send or receive data on the serial LVDS wire pair. The direction of transfer is selected with the ChX_oe pin. If this pin is high, the channel is in transmit mode, if this pin is low, the channel is in receive mode.

The data channel can be configured to deal with different parallel data widths and clocking mechanisms, **Table 29** shows the settings for the ChX_mode[3:0] pins and the modes that they refer to.

For the Channel Clock A/B modes, see “**LVDS SERDES Channel Clock Configuration**” on **page 32** for more details. If the data channel is not needed, then it can be powered down (to reduce overall device power) by tying the ChX_en signal low. This signal must be held high for normal operation.

For a detailed description of how to use the various modes of the data channel to transmit and receive data, see “**LVDS SERDES Transmit and Receive Operation**” on **page 33**.

Table 29: ChX_mode[3:0]

ChX_mode[3]	Description
bit [3]	Low Frequency (1), High Frequency (0) Determines high or low frequency lock range for internal SERDES PLL. When this bit is set to '1', the low frequency range is selected. When this bit is set to '0', the high frequency range is selected.
bit [2]	In 10:1 mode, this bit must be set to '0'. In channel clock mode, the pin setting does not matter.
bit [1]	Embedded clock mode (0), channel-clock (1)
bit [0]	CLKA (1), CLKB (0) channel clock select

LVDS SERDES Channel Clock Configuration

There are two SERDES channel clocks within the core. **Figure 44** shows a representation of the channel clock. Each channel clock is identical.

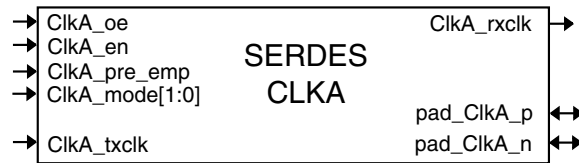

Figure 44: SERDES CLK A

Each of the two SERDES channel clocks can be configured independently. They can be configured to act as the transmit or receive clock for up to 8 SERDES data channels (for serial links where the clock is provided as a separate LVDS wire pair). Alternatively, the channel clock can be configured as a simple bi-directional IO pin, where the internal signals are CMOS, but the external pin is LVDS. In such a case, the I/O will act simply as a level converter.

Since the channel clock may act as a transmit or receive clock (or as an input or output signal in data mode), the direction of the channel clock must be selected with the ClkX_oe pin. If this pin is high, then the channel clock is transmitting a clock (or acting as an output signal in data mode). If this pin is low, then the channel clock is receiving a clock (or acting as an input signal in data mode).

When the channel clocks are used to act as the transmit or receive clock for one or more data channels, then four modes are available, using the CLKx_MODE[1:0] input. **Table 30** shows these modes.

Table 30: ClkX_mode[1:0]

ClkX_mode[1:0]	Mode
00	1:1 mode (no PLL)
01	4:1 mode
10	7:1 mode
11	8:1 mode

When a channel clock is configured with ClkX_MODE[1:0] equal to 01, 10, or 11, then any of the data channels can be configured to use that channel clock as its clock, by setting the data channel's ChX_MODE inputs to point to the correct channel clock. See the **Section**, “**LVDS SERDES Data Channel Configuration**,” on page 31 for more information.

When the channel clock is configured with ClkX_MODE[1:0] equal to 00, the channel clock becomes a simple LVDS-to-CMOS level converter.

When ClkX_oe is high, the channel clock will be configured as an output, in which the data supplied on the ClkX_txclk pin is converted to LVDS and comes out on the pad_ClkX_p and pad_ClkX_n external LDVS signals asynchronously.

When ClkX_oe is low, the channel clock is configured as an LVDS input, in which the LVDS signal on pad_ClkX_p and pad_ClkX_n is converted to CMOS levels and enters the device on the ClkX_rxclk pin.

Any data channel can also be configured as a level translator. This is done by setting that data channel's ChX_mode[3:0] input to point to a channel clock (A or B) which has also been configured in level translator mode.

LVDS SERDES Transmit and Receive Operation

The SERDES core can transmit and receive serial data across LVDS wires in many different formats. This section describes each of the various transmit and receive formats.

Transmit 10-bit Data With Embedded Clock

The waveform in **Figure 19**, illustrates how 10-bit data can be transmitted serially on the differential LVDS outputs.

NOTE: The pad_ChX_p and pad_ChX_n outputs in the diagram are representing the data changes which occur on a pair of LVDS signals.

When the SERDES is in 10-bit mode, no separate clock signal is needed, since the clock is embedded within the serial data stream. In **Figure 19**, you will notice that at t_{DIS} the rising edge of ChX_txclk registers the 10-bit data value B within the SERDES core. After about one clock period of ChX_txclk, the serialized data begins to appear on the LVDS outputs (pad_ChX_p and pad_ChX_n) in the following sequence:

1. First, a logic 1 is transmitted, which is the start bit, and part of the data used to transmit the clock.
2. Then each of the 10 bits of the data value B is transmitted in sequence.
3. Finally, a logic 0 is transmitted, which is the stop bit (MSB first). This stop bit is the remaining part of the embedded clock.

NOTE: By using a stop bit value of 0 and a start bit value of 1, there is always a guaranteed 0 to 1 transition in the bitstream (the end of one frame and the beginning of the next). Because of this, the receiver is able to recover the embedded clock from the serial bit stream.

The pertinent timing parameters shown in **Figure 19** are:

- t_{DIS} is the setup time needed for the ChX_txd bus relative to the ChX_txclk clock
- t_{DIH} is the hold time for the ChX_txd relative to the ChX_txclk clock

Receive 10-bit Data With Embedded Clock

In 10-bit mode, the clock is embedded in the serial data stream on the pad_ChX_p and pad_ChX_n LVDS signal (shown in **Figure 23**) as one signal, but actually is a pair of differential signals). When using the SERDES data channel in 10-bit receive mode, a reference clock is needed which matches the parallel clock rate of the transmitter (shown in **Figure 23** as ChX_txclk). There is no timing phase relationship between the reference clock and the received parallel clock (ChX_rxclk), but the two clocks will have the same frequency.

NOTE: The serial data bits are transmitted with a 0 as a stop bit and a 1 as a start bit, and. The SERDES block recovers the clock from this data stream, as shown with the ChX_rxclk waveform (**Figure 23**). The parallel 10-bit data is also recovered and timed appropriately with the recovered clock.

The pertinent timing parameters shown in **Figure 23** are:

- t_{DD} is the delay from the rising edge of the start bit in the serial bitstream to the rising edge of the recovered parallel clock
- t_{RXPD} is the propagation delay time provided for the recovered data with respect to the recovered clock.

Transmit 8-bit Data With Channel Clock

When the SERDES is in 8-bit mode, it must be configured to use a channel clock. The waveforms shown in **Figure 21** show the parallel transmit clock provided by the user to the clock channel (ClkX_txclk), and the converted channel clock on the LVDS outputs of the channel clock (pad_ClkX_p and pad_ClkX_n).

NOTE: The output of the channel clock has the same period as the parallel transmit clock. This is done to frame the serial data transmitted on the pad_ChX_p and pad_ChX_n pins. The LVDS channel clock (pad_ClkX_p and pad_ClkX_n) is multiplied up by the receiver to capture each bit of the transmitted data.

The 8-bit data is converted to a simple serial bit stream.

The pertinent timing parameters shown in **Figure 21** are:

- t_{DJS} is the setup time needed on the parallel transmit data (ChX_txd[7:0]) with respect to the parallel transmit clock (ClkX_txclk)
- t_{DIH} is the hold time needed on the parallel transmit data (ChX_txd[7:0]) with respect to the parallel transmit clock (ClkX_txclk)
- t_{SD} is the clock delay between the rising edge of the parallel transmit clock to the rising edge of the LVDS channel clock
- $t_{TXD[N-1]}$ is the serial data physical bit position with respect to the LVDS channel clock.

NOTE: $t_{TXD[N-1]}$ denotes physical bit positions wrt pad_ClkX_p/n while pad_ChX_p/n bit[n] refers to logical bit positions wrt ChX_txd[7:0].

Receive 8-bit Data With Channel Clock

The SERDES in 8-bit receive mode receives serial data on the pad_ChX_p and pad_ChX_n LVDS input, and a clock on the pad_ClkX_p and pad_ClkX_n LVDS input (see **Figure 26**). The LVDS input clock is multiplied by 8 within the SERDES core to capture the 8 bits of data from the pad_ChX_p and pad_ChX_n serial bitstream. The parallelized data goes out on the ChX_rxd internal 8-bit bus, and the re-timed parallel clock goes out on the ClkX_rxclk pin.

The pertinent timing parameters shown in this diagram are:

- t_{DD} is the delay between the first bit of the serial data showing up in the serial bit stream and the rising edge of the retimed parallel clock corresponding to the same data frame
- t_{RXPD} is the propagation delay time provided for the recovered data with respect to the recovered clock
- t_{RXDS} is the setup time needed for the serial data on the pad_ChX_p and pad_ChX_n LVDS inputs to the rising edge of the internal serial clock strobe
- t_{RXDH} is the hold time needed for the serial data on the pad_ChX_p and pad_ChX_n LVDS inputs relative to the internal serial clock strobe

- t_{SCD} is the delay between the rising edge of the LVDS channel clock and the first rising edge of the multiplied internal serial clock corresponding to the same data frame.
- $t_{RXD[N-1]}$ is the internal clock strobe positions with respect to the rising edge of the LVDS channel clock

NOTE: $t_{RXD[N-1]}$ denotes physical strobe positions with respect to pad ClkX_p/n while pad_ChX_p/n bit[n] refers to logical bit positions with respect to ChX_rxd[7:0]

Asynchronous Level Conversion Mode for the Data Channel and Channel Clock

When the SERDES data channel ChX_mode[3:0] pins are set to use a channel clock which is in level translator mode, then that data channel is also in level translator mode. In level translator mode, the data channel only converts the internal CMOS signal to LVDS (for output mode), or vice versa for input mode.

When the data channel or channel clock is in this asynchronous signal translation mode, and configured as outputs (ChX_oe or ClkX_oe high) the output mode waveforms in **Figure 22** apply.

When the data channel or channel clock is in this asynchronous signal translation mode, and configured as inputs (ChX_oe or ClkX_oe low) the input mode waveforms in **Figure 27** apply.

Programmable Fabric Description

The QuickSD device features an enhanced Super Logic Cell with an additional D flip-flop register and associated control logic. This advanced architectural approach addresses today's highly register intensive designs.

The QuickSD logic Supercell structure, shown in **Figure 45**, is similar to the .35 mm QuickLogic logic cell with the addition of a second register. Both registers share CLK, SET and RESET inputs. The second register has a two-to-one multiplexer controlling its input. This register can be loaded from the NZ output or directly from a dedicated input.

NOTE: The input "PP" is not an "input" in the classical sense. It can only be tied high or low using default links only and is used to select which path "NZ" or "PS" is used as an input to the register. All other inputs can be connected not only to "tiehi" and "tielo" but to multiple routing channels as well.

The complete logic cell consists of two 6-input AND gates, four two-input AND gates, seven two-to-one multiplexers, and two D flip-flops with asynchronous SET and RESET controls. The cell has a fan-in of 30 (including register control lines) and fits a wide range of functions with up to 17 simultaneous inputs. It has six outputs, of which four are combinatorial and two are registered. The high logic capacity and fan-in of the logic cell accommodate many user functions with a single level of logic delay while other architectures require two or more levels of delay.

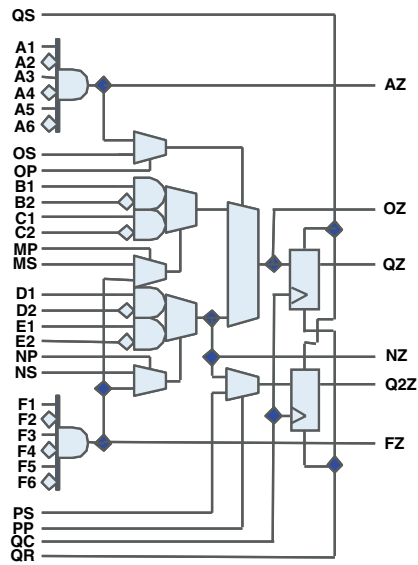

Figure 45: SERDES Logic Cell

RAM Block Description

General Description

The QuickSD device includes multiple dual-port 2,304-bit RAM modules for implementing RAM and FIFO functions. Each module is user-configurable into four different block organizations. Modules can also be cascaded horizontally to increase their effective width or vertically to increase their effective depth as shown in the following figure. The RAM can also be configured as a modified Harvard Architecture, similar to those found in DSPs.

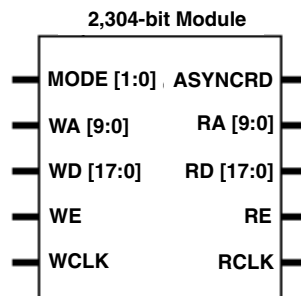

Figure 46: SERDES 2,304-bit RAM Module

There are 36 RAM blocks within the QuickSD device, for a total of 82.9 Kbits of RAM. Using two "mode" pins, designers can configure each module into 128 x 18 (Mode 0), 256 x 9 (Mode 1), 512 x 4 (Mode 2), or 1024 x 2 blocks (Mode 3). The blocks are also easily cascadable to increase their effective width and/or depth. See **Figure 47** for cascaded RAM modules.

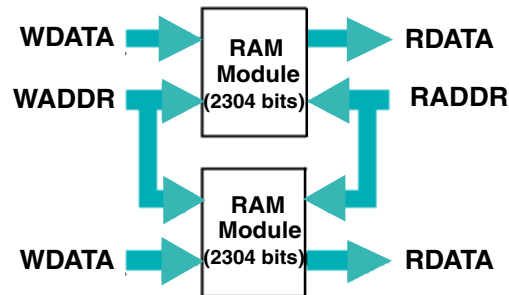

Figure 47: Cascaded RAM Modules

The RAM modules are dual-port, with completely independent READ and WRITE ports and separate READ and WRITE clocks. The READ ports support asynchronous and synchronous operation, while the WRITE ports support synchronous operation. Each port has 18 data lines and 10 address lines, allowing word lengths of up to 18 bits and address spaces of up to 1,024 words. Depending on the mode selected, however, some higher order data or address lines may not be used.

The Write Enable (WE) line acts as a clock enable for synchronous write operation.

The Read Enable (RE) acts as a clock enable for synchronous READ operation (ASYNCRD input low), or as a flow-through enable for asynchronous READ operation (ASYNCRD input high).

Designers can cascade multiple RAM modules to increase the depth or width allowed in single modules by connecting corresponding address lines together and dividing the words between modules.

A similar technique can be used to create depths greater than 512 words. In this case address signals higher than the ninth bit are encoded onto the write enable (WE) input for WRITE operations. The READ data outputs are multiplexed together using encoded higher READ address bits for the multiplexer SELECT signals.

The RAM blocks can be loaded with data generated internally (typically for RAM or FIFO functions). The RAM achieve 155 MHz performance for the lowest speed grade devices when using multiple blocks cascaded together.

Multiple Accessing of Memories

The extremely fast RAM can be used in designs that require multiple memory accessing. The RAM achieves 280 MHz performance for the fastest speed grade and 155 MHz performance for the lowest speed grade devices when using multiple blocks cascaded together. Write through of DATA is also possible with the QuickLogic RAM.

ECU Block Description

ECU Block General Description

Traditional Programmable Logic architectures do not implement arithmetic functions efficiently or effectively. These functions require high logic cell usage while garnering only moderate performance results. By embedding a dynamically reconfigurable computational unit, the QuickSD device can address various arithmetic functions efficiently and effectively providing for a robust DSP platform—this approach offers greater performance than traditional programmable logic implementations. The ECU block is ideal for complex DSP, filtering, and algorithmic functions. The QuickSD device architecture will allow functionality above and beyond that achievable using DSP processors or programmable logic devices. The embedded block is implemented at the transistor level with the following block diagram.

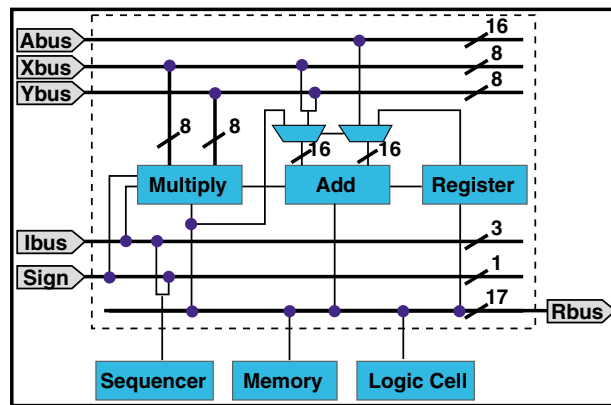

Figure 48: SERDES ECU Block Diagram

ECU Mode Select

Table 31: Instruction Set Sequencer

Instruction Set			Operation
0	0	0	Multiply
0	0	1	Multiply - Add
0	1	0	Accumulate
0	1	1	Add
1	0	0	Multiply (registered) ^a
1	0	1	Multiply - Add (registered)
1	1	0	Multiply Accumulate
1	1	1	Add (registered)

a. A[15:0] set to zero.

The ECU block can be configured for eight arithmetic functions via an instruction as shown in **Table 31**. The modes for the ECU block are Dynamically Re-programmable through the Instruction Set Sequencer.

Clock Networks Description

Global Clocks

In the QuickSD device, there are nine global clock networks: one is dedicated and eight are programmable. Global clocks can drive logic cell, I/O, ECU blocks and RAM registers in the device. Five global clocks will have access to a Quad Net (local clock network) connection with a programmable connection to the register inputs. **Figure 49** gives the global clock methodology

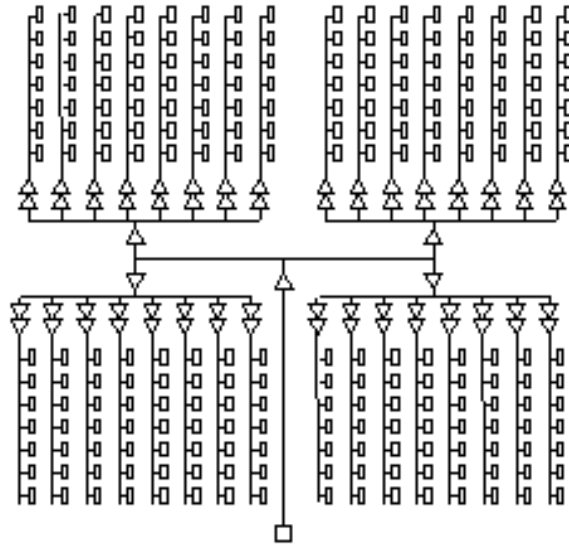

Figure 49: Global Clock

Quad-Net Network

There are five Quad-Net local clock networks in each quadrant for a total of 20 in a device. Each Quad-Net is local to a quadrant. Quad-Net is multiplexed with the clock buffer before driving the column clock buffers.

Dedicated Clock

There is one dedicated clock in QuickSD devices. It connects to the clock input of the SuperCell, I/O, and RAM registers through a hardwired connection and is multiplexed with the programmable clock input. There are four inversions from pad to register inputs and the dedicated clock takes on the same configuration as the global clock. The dedicated clock provides a fast global network with low skew. You can select either the dedicated clock or the programmable clock; **Figure 50** gives the dedicated clock circuitry within the logic cell.

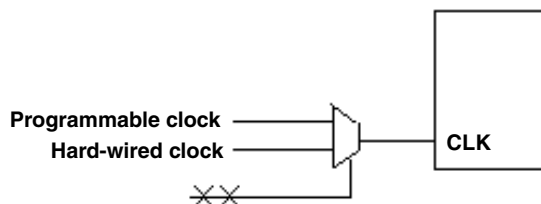

Figure 50: Dedicated Clock Circuitry

The performance of the dedicated clock is given in **Table 32**

Table 32: Dedicated Clock Performance

Clock Performance		
TT, 25C, 2.5 V	Global	Dedicated
Macro (rear)	1.51	1.59
I/O (far)	2.06	1.73
Skew	0.55	0.14

I/O Cell Structure

I/O Cell Structure General Description

The QuickSD device features a variety of distinct I/O pins to maximize performance, functionality, and flexibility with bi-directional I/O pins and input-only pins. All input and I/O pins are 2.5 V and 3.3 V tolerant and comply with the specific I/O standard selected. The outputs swing from V_{SS} to V_{CCIO} (0 V to 3.3 V \pm 10%). The V_{CCIO} pins must be tied to a 3.3 V supply to provide 3.3 V compliance.

If 3.3 V compliance is not required, then these pins must be tied to the 2.5 V supply.

Table 33 summarizes the I/O specifications that are supported.

Table 33: Supported I/O Specifications

I/O Standard	Reference Voltage	Output Voltage	Application
LVTTL	n/a	3.3	general purpose
LVC MOS2	n/a	2.5	general purpose
PCI	n/a	3.3	PCI bus applications
GTL+	1	n/a	high speed bus - Pentium Pro
SSTL3	1.5	3.3	memory bus - Hitachi, IBM
SSTL2	1.25	2.5	memory bus - Hitachi, IBM

As designs become more complex and requirements more stringent, varying I/O standards are developing for specific applications. I/O standards for processors, memories and various bus applications have become common place and a requirement for many systems. In addition, I/O timing has become a greater issue with specific requirements for setup, hold, clock to out, and switching times.

The QuickSD device has addressed these changing system requirements. The QuickSD device includes a completely new I/O cell which consists of programmable I/Os as well as a new cell structure consisting of three registers: input, output and output enable. The QuickSD device offers banks of programmable I/O that addresses many of the new bus standards that are popular today. In addition, the input register addresses the setup time, the output register addresses clock-to-out time, and the OE register addresses the switching time from high impedance to a given value.

Figure 51 shows the QuickSD device I/O cell.

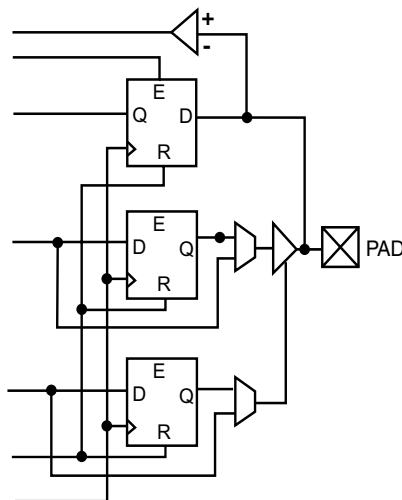

Figure 51: QuickSD I/O Cell

The bi-directional I/O pin options can be programmed for input, output, or bi-directional operation. Each bi-directional I/O pin is associated with an I/O cell which features an input/feedback register, an input buffer, output/feedback register, three-state output buffer, an output enable register, and two 2-to-1 multiplexers.

For input functions, I/O pins can provide combinatorial registered data or both options simultaneously to the logic array. For combinatorial input operation, data is routed from I/O pins through the input buffer to the array logic. For registered input operation, I/O pins drive the D input of input cell registers, allowing data to be captured with fast set-up times without consuming internal logic cell resources.

For output functions, I/O pins can receive combinatorial or registered data from the logic array. For combinatorial output operation, data is routed from the logic array through a multiplexer to the I/O pin. For registered output operation, the array logic drives the D input of the output cell register which in turn drives the I/O pin through a multiplexer. The multiplexer allows either a combinatorial or a registered signal to be driven to the I/O pin.

The three-state output buffer controls the flow of data from the array logic to the I/O pin and allows the I/O pin to act as an input and/or output. The buffer's output enable can be individually controlled by a logic cell array or any pin (through the regular routing resources), or bank-controlled through one of the global networks.

The signal can also be either combinatorial or registered. This is identical to that of the flow for the output cell. For combinatorial control operation, data is routed from the logic array through a multiplexer to the three-state control. For registered control operation, the array logic drives the D input of the OE cell register which in turn drives the three-state control through a multiplexer. The multiplexer allows either a combinatorial or a registered signal to be driven to the three-state control.

For output functions, I/O pins can be individually configured for active HIGH, active LOW, or open-drain inverting operation. In the active HIGH and active LOW modes, the pins of all devices are fully 3.3 V compliant.

When I/O pins are unused, the OE controls can be permanently disabled, allowing the output cell register to be used for registered feedback into the logic array.

I/O cell registers are controlled by clock, clock enable, and reset signals, which can come from the regular routing resources, from one of the global networks, or from two input pins per bank of I/O's. The CLK and RESET signals share a common line, while the clock enables for each register can be independently controlled. Additionally, the output and enable registers will increase a device's register count. The addition of an output register will also decrease the TCO. Since the output register does not need to drive the routing, the length of the output path is also reduced.

Extra registers add more inputs and outputs to the I/O structure. Extra routing resources are added to connect the I/O structure to the other parts of the device.

I/O interface support is programmable on a per bank basis. There are 4 I/O banks per chip. Users can not mix a 2.5 volt I/O with 3.3 volt I/O on the same I/O bank. **Figure 52** illustrates the multiple I/O bank configurations.

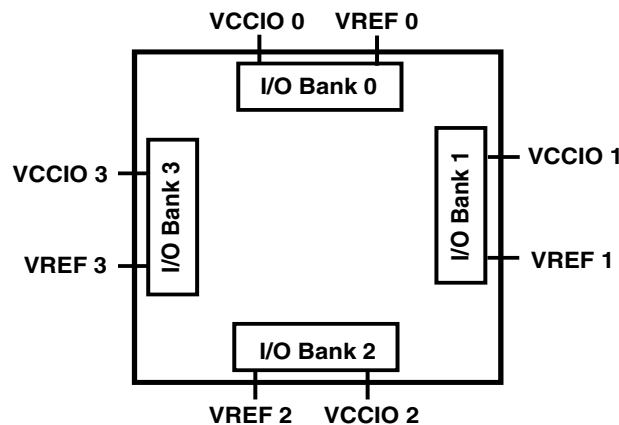

Figure 52: Multiple I/O Bank Configurations

Each I/O bank is independent of other I/O banks and each I/O bank has its own V_{CCIO} and V_{REF} supplies. A mixture of different I/O standards can be used on the device; however, there is a limitation as to which I/O standards can be supported within a given bank. Differential I/O can be shared with non differential I/O. There can only be one V_{REF} and one V_{CCIO} per bank.

Programmable Slew Rate

Each I/O has programmable slew rate capability. The rate is programmable to one of two slew rates: either fast or slow. The slower rate can be used to reduce ground bounce noise. The slow slew rate is 1 V/ns under typical conditions. The fast slew rate is 2.8 V/ns

Table 34: 3.3 V Slew Rate

VCCIO = 3.3 V	Fast Slew	Slow Slew
Rising Edge	2.8 V/nS	1.0 V/vS
Falling Edge	2.86 V/nS	1.0 V/nS

Table 35: 2.5 V Slew Rate

VCCIO = 2.5 V	Fast Slew	Slow Slew
Rising Edge	1.7 V/nS	0.6 V/vS
Falling Edge	1.9 V/nS	0.6 V/nS

NOTE: Condition: 2.5 V, 25 °C

Programmable Weak-Pull

Programmable weak pull-down resistors are available on each I/O. I/O Weak Pull-Down eliminates the need for an external pull-down resistor for used I/O. The spec for pull-down current is a maximum of 150 uA under a worst case condition. -148 uA @ 3.6 V, -55 °C, - 69 uA@ 2.5 V, 25 °C. **Figure 53** illustrates the weak pull-down circuit.

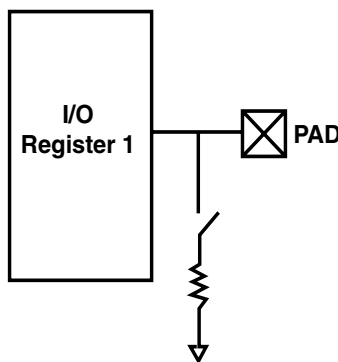

Figure 53: I/O Weak Pull-Down Circuit

I/O Control and Local Hi-Drives

Each bank of I/Os has two input-only pins that can be programmed to drive the RST, CLK, and EN inputs of I/O's in that bank. These input-only pins also double up as high-drive inputs to a quadrant. Both as an I/O control or high-drive, these buffers can be driven by the internal logic. The I/O control network and local high-drive performance is indicated in **Table 36**.

Table 36: I/O Control Network/ Local Hi-Drive Performance

TT, 25C, 2.5V	From Pad	From Array
I/O (slow)	1.00 ns	1.14 ns
I/O (fast)	0.63 ns	0.78 ns
Skew	0.37 ns	0.36 ns

Programmable Logic Routing

The QL82SD device provides six types of routing resources (as in the QuickRAM devices): short (sometimes called segmented) wires, dual wires, quad wires, express wires, distributed networks, and defaults.

- Short wires span the length of one logic cell, always in the vertical direction. Dual wires run horizontally and span the length of two logic cells.

NOTE: Short and dual wires are predominantly used for local connections. They effectively traverse one or two logic cells that utilize an interconnect element to continue to the next cell or to change direction.

- Quad wires have passive link interconnect elements every fourth logic cell. As a result, these wires are typically used to implement intermediate or medium length fan-out nets.
- Express lines run the length of the programmable logic uninterrupted. Each of these lines has a higher capacitance than a quad, dual or short wire, but less capacitance than shorter wires connected to run the length of the device. The resistance will also be lower because the express wires don't require the use of "pass" links. Express wires provide higher performance for long routes or high fan-out nets.
- Distributed networks are described in the clock/control section. These wires span the programmable logic, and are driven by "column clock" buffers. Each dedicated clock network pin buffer is hard wired to a set of column clock buffers. Five global networks "global buffers" can be connected through special purpose routing called "HSCK lines" to either a dedicated pin buffer, or any vertical routing wire crossing it.

Global POR (Power-On Reset)

The QuickSD device features a global power-on reset. This reset will be hardwired to all registers and will reset the registers upon power-up of the device. The circuitry used to support the global POR is similar to the power-up loading circuitry.

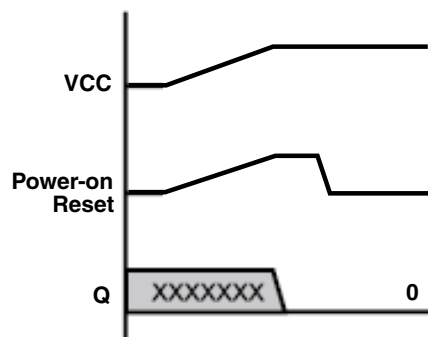

Figure 54: Power-On Reset

Separate Power & Logic Cell Power

To decrease the logic cell area and to eliminate the need for disable transistors in the input stage of the logic cell, a separate power supply for the logic cells has been added to the QuickSD device. This supply will be grounded during programming and for various test modes.

IEEE Standard 1149.1a

The QuickSD device supports IEEE standard 1149.1a. The following public instructions are supported: BYPASS, EXTEST, and SAMPLE/PRELOAD. Two additional modes RAMWT and RAMRD can be used to load the RAM.

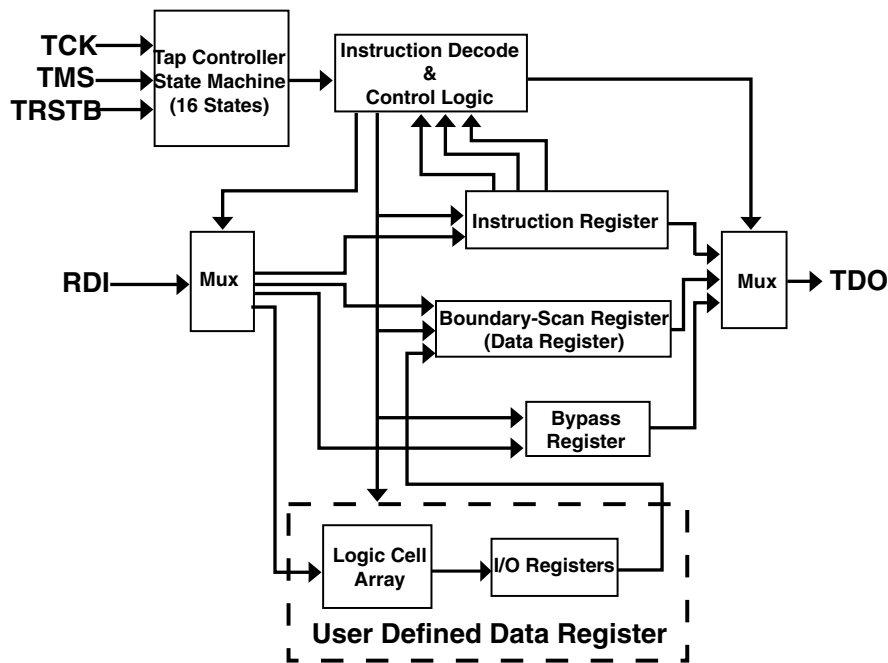

Figure 55: JTAG Block Diagram

JTAG BSDL Support

- BSDL-Boundary Scan Description Language
- Machine-readable data for test equipment to generate testing vectors and software
- BSDL files available for all device/ package combinations from QuickLogic
- Extensive industry support available and ATG (Automatic Test-vector Generation)

Security Fuses

There are two security links, one to disable reading from the array and the other to disable JTAG.

8-bit Programming

The QuickSD device has 8-bit programming capability. The addition of four extra programming supplies is used in the reduction of programming time.

Pin Type Description

General Pins

Table 37: General Pin Descriptions

Type	Description
IN	Input. A standard input-only signal
OUT	Totem pole output. A standard active output driver
T/S	Tri-state. A bi-directional, tri-state input/output pin

Table 38: General Pin/Bus Descriptions

Pin/Bus Name	Type	Function
VCC	IN	Supply pin. Tie to 2.5 V supply.
VCCIO	IN	Supply pin for I/O. Set to 2.5 V for 2.5 V I/O, 3.3 V for 3.3 V compliant I/O, or refer to the I/O Standards table.
INREF	IN	Differential I/O Reference Voltage, refer to Differential Voltage Table. Connect to GND when using TTL, PCI or LVCMOS
VCCREC	IN	LVDS Receiver VCC Supply. Connect to 3.3 V
VCCPLL	IN	PLL VCC Supply. Connect to 2.5 V
IOCTRL	IN	Low Skew I/O Control Pins. Tie to GND if unused
GNDPLL	IN	Tie to GND
CLK/PLLIN	IN	Programmable Global Clock Pin or Programmable PLL Input. Tie to VCC or GND if unused
CLK/DEDCLK/PLLIN	IN	Dedicated Global Clock Pin or Programmable PLL Input.
PLLOUT	OUT	Programmable PLL Output
PLL_RST	IN	Programmable PLL Reset. Tie to VCC if the PLL is unused.
GND	IN	Ground pin. Tie to GND on the PCB.
T/GND	IN	Thermal Ground. Used to dissipate heat from the device. Tie to GND on the PCB.
I/O	T/S	Programmable Input/Output/Tri-State/Bi-directional Pin.
CLK	IN	Programmable Global Clock Pin. Tie to VCC or GND if unused.
TDI	IN	JTAG Data In. Tie to VCC if unused.
TDO	OUT	JTAG Data Out. Leave unconnected if unused.
TCK	IN	JTAG Clock. Tie to GND if unused.
TMS	IN	JTAG Test Mode Select. Tie to VCC if unused.
TRSTB	IN	JTAG Reset. Tie to GND if unused.
NC	OUT	Must be isolated and floating at all times

LVDS SERDES External Signals

Table 39: LVDS SERDES External Signals

Signal Name	Description
CH0P, CH0N	LVDS signal pair for data channel 0
CH1P, CH1N	LVDS signal pair for data channel 1
CH2P, CH2N	LVDS signal pair for data channel 2
CH3P, CH3N	LVDS signal pair for data channel 3
CH4P, CH4N	LVDS signal pair for data channel 4
CH5P, CH5N	LVDS signal pair for data channel 5
CH6P, CH6N	LVDS signal pair for data channel 6
CH7P, CH7N	LVDS signal pair for data channel 7
CLKAP, CLKAN	LVDS signal pair for channel clock A
CLKBP, CLKBN	LVDS signal pair for channel clock B

LVDS SERDES Internal Signals (Data Channels 0 to 7)

Table 40: LVDS SERDES Internal Signals (Data Channels 0 to 7)

Signal Name	Description
Ch0_rst	Channel 0 Reset Signal
Ch0_oe	Channel 0 Output Enable (1=transmit, 0=receive)
Ch0_en	Channel 0 Enable (reduces power when set to 0)
Ch0_mode[3:0]	Channel 0 MODE pins. See the SERDES Data Channel Functional Description
Ch0_txd[9:0]	Channel 0 Parallel Transmit Data Bus
Ch0_txclk	Channel 0 Transmit/Reference Clock
Ch0_sync	Channel 0 Sync Control. When low, a sync pattern is generated on the CH0_DATA pins to provide a high-speed lock mechanism when using the embedded clock mode. When high, it will send the data in ChX_txd.
Ch0_rxd[9:0]	Channel 0 Parallel Receive Data Bus
Ch0_rxclk	Channel 0 Receive Clock
Ch0_lock	Channel 0 Lock indicator, to indicate when the SERDES is locked to the serial bitstream, when using the embedded clock mode.
Ch0_pre_emp	Channel 0 pre-emphasis signal. When high, LVDS transmitter boosts dynamic current during signal transitions.

NOTE:

All Ch0 signals above repeat for Ch1-Ch7. The eight SERDES data channels 0 through 7 are identical.

LVDS SERDES Internal Signals (Channel Clocks A and B)

Table 41: LVDS SERDES Internal Signals (Channel Clocks A and B)

Signal Name	Description
ClkA_rst	Channel Clock A Reset Signal
ClkA_oe	Channel Clock A Output Enable (1 =transmit, 0=receive)
ClkA_en	Channel Clock A Enable (reduces power when set to 0)
ClkA_mode[1:0]	Channel Clock A MODE pins. See the SERDES Channel Clock Functional Description
ClkA_txclk	Channel Clock A Parallel Transmit Clock
ClkA_rxclk	Channel Clock A Parallel Receive Clock

NOTE: All ClkA signals above repeat for ClkB. SERDES channel clocks A and B are identical.

208 PQFP Pinout Diagram

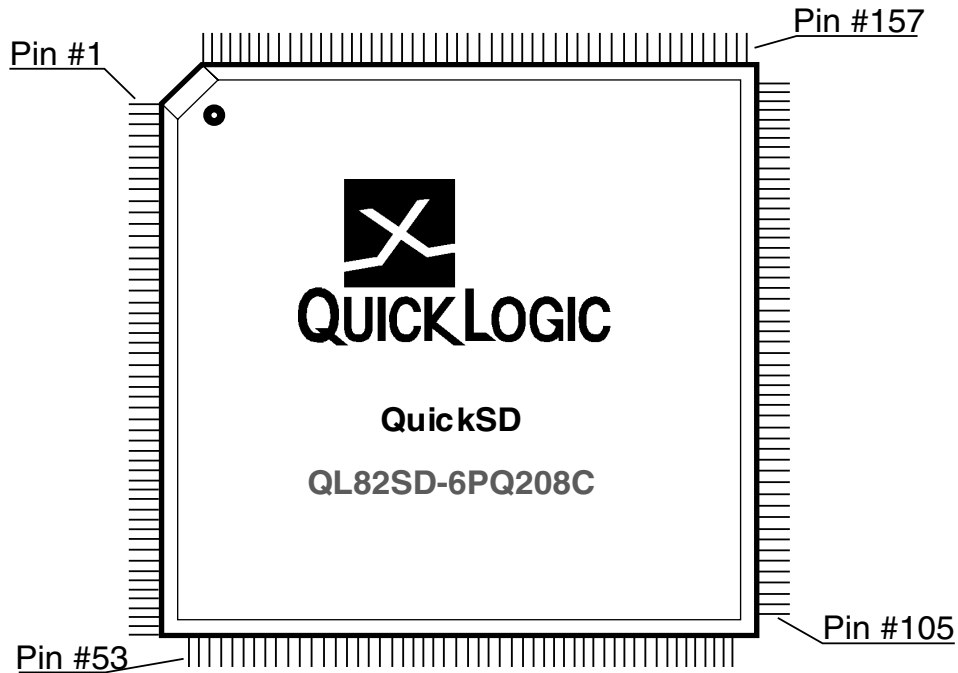

Figure 56: QL82SD - 208PQFP Pinout Diagram

208 PQFP Pinout Table

Table 42: 208 PQFP Pinout Table

PIN	Function	Pin	Function	Pin	Function	Pin	Function	Pin	Function
1	VCCPLL	43	VCCPLL	85	INREF(A)	127	GND	169	IO(D)
2	GNDPLL	44	GNDPLL	86	IOCTRL(A)	128	CLK(5)	170	VCCIO(D)
3	VCC	45	GND	87	VCC	129	CLK(6)	171	VCC
4	GND	46	Ch7N	88	IO(A)	130	CLK(7)	172	IO(D)
5	Ch0N	47	Ch7P	89	IO(A)	131	CLK(8)	173	IO(D)
6	Ch0P	48	GND	90	VCCIO(A)	132	TMS	174	IO(D)
7	GND	49	VCC	91	IO(A)	133	GND	175	IOCTRL(D)
8	VCC	50	GND	92	IO(A)	134	IO(C)	176	INREF(D)
9	GND	51	VCCREC	93	IO(A)	135	IO(C)	177	IOCTRL(D)
10	VCCREC	52	VCC	94	IO(A)	136	IO(C)	178	IO(D)
11	VCCPLL	53	GND	95	GND	137	IO(C)	179	IO(D)
12	GNDPLL	54	VCC	96	IO(A)	138	VCC	180	IO(D)
13	VCC	55	GND	97	IO(A)	139	IO(C)	181	IO(D)
14	GND	56	VCC	98	IO(B)	140	VCCIO(C)	182	VCCIO(D)
15	Ch1N	57	TRSTB	99	IO(B)	141	IO(C)	183	IO(D)
16	Ch1P	58	CLK(2)	100	IO(B)	142	VCC	184	IO(D)
17	VCC	59	CLK(3)PLL N(1)	101	IO(B)	143	IO(C)	185	VCC
18	GND	60	CLK(4)DED CLK, PLLIN(0)	102	PLLOUT(0)	144	IOCTRL(C)	186	GND
19	VCCREC	61	IO(A)	103	GNDPLL(1)	145	INREF(C)	187	IO(D)
20	GND	62	IO(A)	104	GND	146	GND	188	IO(D)
21	VCC	63	IO(A)	105	PLLRST(1)	147	IOCTRL(C)	189	IO(D)
22	GND	64	IO(A)	106	VCCPLL(1)	148	IO(C)	190	IO(D)
23	GND	65	VCC	107	VCCIO(B)	149	IO(C)	191	VCC
24	CikAN	66	GND	108	IO(B)	150	IO(C)	192	VCCIO(D)
25	CikAP	67	VCCIO(A)	109	GND	151	VCC	193	IO(D)
26	VCC	68	IO(A)	110	IO(B)	152	IO(C)	194	IO(D)
27	CikBN	69	IO(A)	111	IO(B)	153	GND	195	GND
28	CikBP	70	VCC	112	VCC	154	VCCIO(C)	196	IO(D)
29	GND	71	IO(A)	113	IO(B)	155	PLLOUT(1)	197	IO(D)
30	VCCREC	72	IO(A)	114	IO(B)	156	GNDPLL(0)	198	VCC
31	VCC	73	IO(A)	115	IO(B)	157	GND	199	CLK(0)
32	GND	74	IO(A)	116	IO(B)	158	PLLRST(0)	200	CLK(1)
33	GND	75	IO(A)	117	IOCTRL(B)	159	VCCPLL(0)	201	TCK
34	VCCPLL	76	IO(A)	118	INREF(B)	160	IO(C)	202	VCC
35	GNDPLL	77	IO(A)	119	IOCTRL(B)	161	IO(C)	203	TDI
36	Ch6N	78	IO(A)	120	GND	162	IO(C)	204	GND
37	Ch6P	79	VCCIO(A)	121	IO(B)	163	IO(D)	205	VCC
38	GND	80	VCC	122	VCCIO(B)	164	IO(D)	206	GND
39	VCC	81	IO(A)	123	IO(B)	165	IO(D)	207	TDO
40	GND	82	GND	124	VCC	166	IO(D)	208	GND
41	VCCREC	83	IO(A)	125	IO(B)	167	GND		
42	VCC	84	IOCTRL(A)	126	VCC	168	IO(D)		

280 FPBGA Pinout Diagram

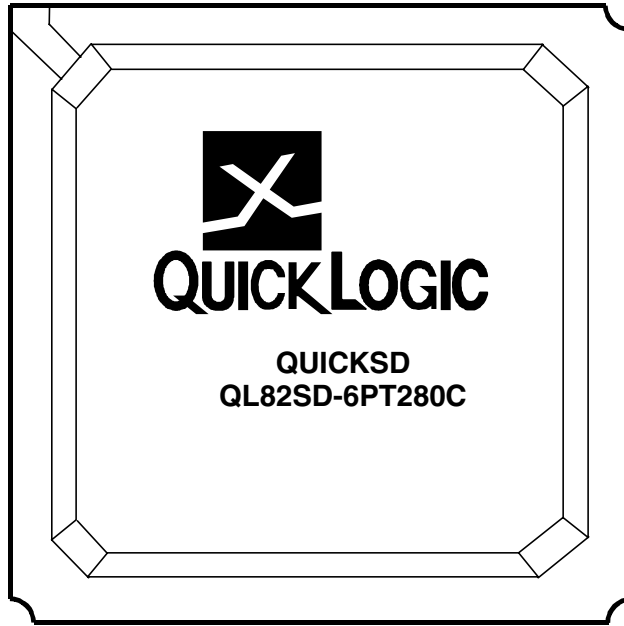

Figure 57: QL82SD - 280 FPBGA Top View

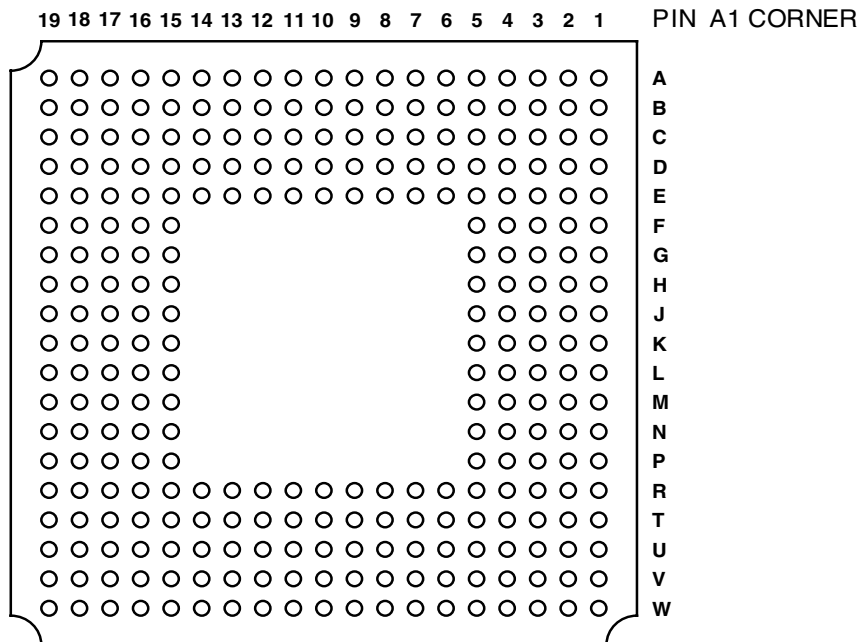

Figure 58: QL82SD - 280 FPBGA Bottom View

280 FPBGA Pinout Table

Table 43: 280 FPBGA Pinout Table

Pin	Function	Pin	Function	Pin	Function	Pin	Function	Pin	Function	Pin	Function
A1	PLLOUT(1)	C10	CLK(8)	E19	IO(B)	K16	IO(A)	R4	VCC	U13	VCCPLL
A2	IO(C)	C11	VCCIO(B)	F1	IO(D)	K17	IO(A)	R5	VCC	U14	GNDPLL
A3	IO(C)	C12	IO(B)	F2	IO(D)	K18	INREF(A)	R6	VCC	U15	VCCPLL
A4	IO(C)	C13	IO(B)	F3	IO(D)	K19	IOCTRL(A)	R7	VCC	U16	GNDPLL
A5	INREF(C)	C14	IO(B)	F4	IO(D)	L1	IO(D)	R8	VCC	U17	VCCPLL
A6	IOCTRL(C)	C15	VCCIO(B)	F5	GND	L2	IO(D)	R9	VCC	U18	GNDPLL
A7	IO(C)	C16	IO(B)	F15	VCC	L3	IO(D)	R10	VCC	U19	VCCREC
A8	IO(C)	C17	VCCPLL(1)	F16	IO(A)	L4	IO(D)	R11	VCC	V1	VCCREC
A9	IO(C)	C18	GNDPLL(1)	F17	IO(A)	L5	VCC	R12	VCC	V2	VCCREC
A10	CLK(7)	C19	PLLOUT(0)	F18	IO(A)	L15	GND	R13	VCC	V3	VCCREC
A11	IO(B)	D1	IO(C)	F19	IO(B)	L16	IO(A)	R14	VCC	V4	VCCREC
A12	IO(B)	D2	IO(C)	G1	IO(D)	L17	IO(A)	R15	VCC	V5	VCCREC
A13	IOCTRL(B)	D3	VCCPLL(0)	G2	IO(D)	L18	IO(A)	R16	CLK(2)	V6	VCCREC
A14	IOCTRL(B)	D4	IO(C)	G3	IO(D)	L19	IO(A)	R17	TRSTB	V7	VCCREC
A15	IO(B)	D5	IO(C)	G4	IO(D)	M1	IO(D)	R18	IO(A)	V8	VCCREC
A16	IO(B)	D6	IO(C)	G5	VCC	M2	IO(D)	R19	IO(A)	V9	VCCREC
A17	IO(B)	D7	IO(C)	G15	VCC	M3	VCCIO(D)	T1	IO(D)	V10	VCCREC
A18	IO(B)	D8	IO(C)	G16	IO(A)	M4	IO(D)	T2	GND	V11	VCCREC
A19	IO(B)	D9	IO(C)	G17	IO(A)	M5	VCC	T3	GND	V12	VCCREC
B1	PLL RST(0)	D10	IO(C)	G18	IO(A)	M15	VCC	T4	GND	V13	VCCREC
B2	IO(C)	D11	CLK(6)	G19	IO(A)	M16	IO(A)	T5	GND	V14	VCCREC
B3	IO(C)	D12	IO(B)	H1	IO(D)	M17	VCCIO(A)	T6	GND	V15	VCCREC
B4	IO(C)	D13	IO(B)	H2	IO(D)	M18	IO(A)	T7	GND	V16	VCCREC
B5	IOCTRL(C)	D14	IO(B)	H3	IO(D)	M19	IO(A)	T8	GND	V17	VCCREC
B6	IO(C)	D15	IO(B)	H4	IO(D)	N1	IO(D)	T9	GND	V18	VCCREC
B7	IO(C)	D16	IO(B)	H5	VCC	N2	CLK(0)	T10	GND	V19	Ch7P
B8	IO(C)	D17	IO(B)	H15	VCC	N3	IO(D)	T11	GND	W1	Ch0N
B9	TMS	D18	IO(B)	H16	IO(A)	N4	IO(D)	T12	GND	W2	Ch0P
B10	CLK(5)	D19	IO(B)	H17	IO(A)	N5	VCC	T13	GND	W3	Ch1N
B11	IO(B)	E1	IO(C)	H18	IO(A)	N15	VCC	T14	GND	W4	Ch1P
B12	IO(B)	E2	IO(C)	H19	IO(A)	N16	IO(A)	T15	GND	W5	Ch2N
B13	IO(B)	E3	VCCIO(D)	J1	IOCTRL(D)	N17	IO(A)	T16	GND	W6	Ch2P
B14	INREF(B)	E4	IO(D)	J2	INREF(D)	N18	IO(A)	T17	GND	W7	Ch3N
B15	IO(B)	E5	GND	J3	VCCIO(D)	N19	IO(A)	T18	IO(A)	W8	Ch3P
B16	IO(B)	E6	VCC	J4	IO(D)	P1	IO(D)	T19	IO(A)	W9	ClkAN
B17	IO(B)	E7	VCC	J5	GND	P2	TCK	U1	TDO	W10	ClkAP
B18	PLL RST(1)	E8	VCC	J15	VCC	P3	IO(D)	U2	VCCPLL	W11	ClkBN
B19	GND	E9	VCC	J16	IO(A)	P4	IO(D)	U3	GNDPLL	W12	ClkBP
C1	IO(C)	E10	GND	J17	VCCIO(A)	P5	VCC	U4	VCCPLL	W13	Ch4N
C2	GND	E11	GND	J18	IO(A)	P15	GND	U5	GNDPLL	W14	Ch4P
C3	GNDPLL(0)	E12	VCC	J19	IOCTRL(A)	P16	CLK(4) DEDCLK, PLLIN(0)	U6	VCCPLL	W15	Ch5N
C4	IO(C)	E13	VCC	K1	IO(D)	P17	CLK(3) PLLIN(1)	U7	GNDPLL	W16	Ch5P
C5	VCCIO(C)	E14	GND	K2	IOCTRL(D)	P18	IO(A)	U8	VCCPLL	W17	Ch6N
C6	IO(C)	E15	GND	K3	IO(D)	P19	IO(A)	U9	GNDPLL	W18	Ch6P
C7	IO(C)	E16	IO(A)	K4	IO(D)	R1	IO(D)	U10	NC	W19	Ch7N
C8	IO(C)	E17	VCCIO(A)	K5	GND	R2	TDI	U11	VCCPLL		
C9	VCCIO(C)	E18	IO(B)	K15	GND	R3	CLK(1)	U12	GNDPLL		

484 PBGA Pinout Diagram

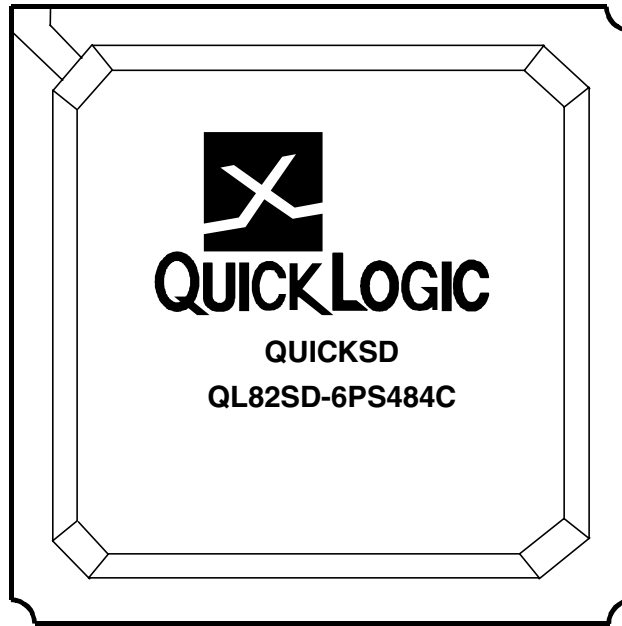

Figure 59: QL82SD - 484PBGA Top View

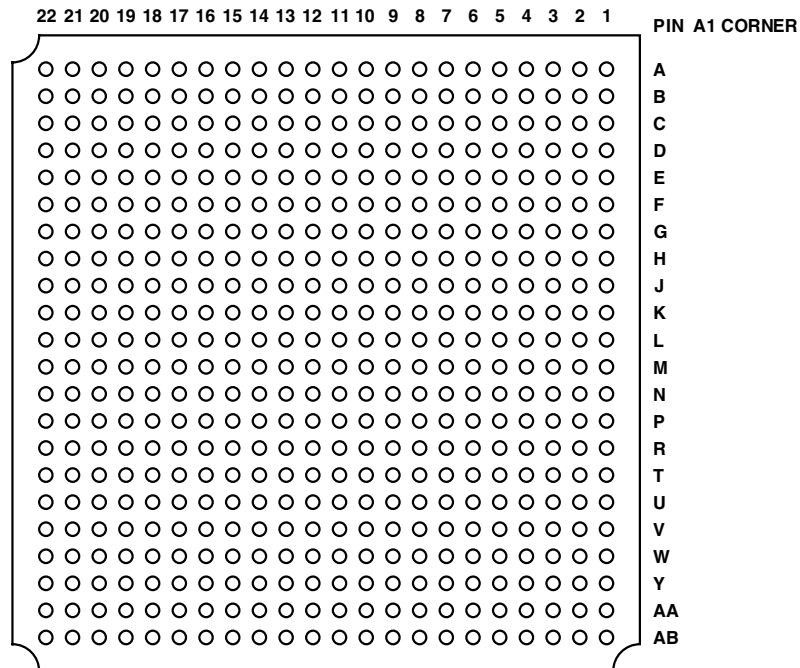

Figure 60: QL82SD - 484PBGA Bottom View

484 PBGA Pinout Table

Table 44: 484 PBGA Pinout Table

Pin	Function	Pin	Function	Pin	Function	Pin	Function	Pin	Function	Pin	Function
A1	GND	D17	I/O<D>	H11	VCC	M5	GND	R21	I/O	W15	I/O<A>
A2	NC	D18	I/O<C>	H12	GND	M6	VCC	R22	I/O	W16	I/O<A>
A3	I/O<D>	D19	VCCPLL<0>	H13	VCC	M7	VCC	T1	CH5N	W17	NC
A4	I/O<D>	D20	I/O<C>	H14	VCC	M8	VCC	T2	VCCREC	W18	I/O
A5	I/O<D>	D21	I/O<C>	H15	GND	M9	VCC	T3	VCCREC	W19	I/O
A6	I/O<D>	D22	I/O<C>	H16	NC	M10	GND	T4	VCCPLL	W20	I/O
A7	I/O<D>	E1	CH1P	H17	NC	M11	GND	T5	GND	W21	I/O
A8	I/O<D>	E2	VCCREC	H18	I/O<C>	M12	GND	T6	VCC	W22	I/O
A9	I/O<D>	E3	VCCREC	H19	I/O<C>	M13	GND	T7	GND	Y1	CH7N
A10	I/O<D>	E4	GNDPLL	H20	I/O<C>	M14	GND	T8	NC	Y2	VCCREC
A11	I/O<D>	E5	GND	H21	I/O<C>	M15	GND	T9	NC	Y3	GND
A12	IOCTRL<D>	E6	NC	H22	I/O<C>	M16	GND	T10	NC	Y4	NC
A13	I/O<D>	E7	NC	J1	CH3P	M17	I/O	T11	GND	Y5	I/O<A>
A14	I/O<D>	E8	CLK<1>	J2	VCCREC	M18	I/O	T12	NC	Y6	I/O<A>
A15	I/O<D>	E9	I/O<D>	J3	VCCREC	M19	I/O	T13	NC	Y7	I/O<A>
A16	I/O<D>	E10	I/O<D>	J4	GNDPLL	M20	CLK<7>	T14	NC	Y8	I/O<A>
A17	I/O<D>	E11	NC	J5	GND	M21	CLK<5>/PLL IN<3>	T15	NC	Y9	I/O<A>
A18	I/O<C>	E12	I/O<D>	J6	VCC	M22	TMS	T16	GND	Y10	I/O<A>
A19	I/O<C>	E13	I/O<D>	J7	VCC	N1	CLKBP	T17	I/O	Y11	I/O<A>
A20	GND	E14	I/O<D>	J8	VCC	N2	VCCREC	T18	I/O	Y12	IOCTRL<A>
A21	PLLOUT<1>	E15	I/O<D>	J9	GND	N3	VCCREC	T19	I/O	Y13	IOCTRL<A>
A22	I/O<C>	E16	I/O<C>	J10	VCC	N4	GNDPLL	T20	I/O	Y14	I/O<A>
B1	CH0N	E17	I/O<D>	J11	VCC	N5	GND	T21	IOCTRL	Y15	I/O<A>
B2	GND	E18	I/O<C>	J12	GND	N6	VCC	T22	I/O	Y16	I/O<A>
B3	TDO	E19	I/O<C>	J13	VCC	N7	VCC	U1	CH5P	Y17	I/O<A>
B4	GND	E20	I/O<C>	J14	GND	N8	VCC	U2	VCCREC	Y18	I/O
B5	I/O<D>	E21	I/O<C>	J15	VCC	N9	VCC	U3	VCCREC	Y19	PLLOUT<0>
B6	I/O<D>	E22	I/O<C>	J16	NC	N10	GND	U4	GNDPLL	Y20	PLLRST<1>
B7	TDI	F1	CH2N	J17	VCCIO<C>	N11	GND	U5	GND	Y21	I/O
B8	I/O<D>	F2	VCCREC	J18	I/O<C>	N12	GND	U6	VCC	Y22	I/O
B9	I/O<D>	F3	VCCREC	J19	I/O<C>	N13	GND	U7	VCCIO<A>	AA1	CH7P
B10	I/O<D>	F4	VCCPLL	J20	I/O<C>	N14	VCC	U8	I/O<A>	AA2	GND
B11	I/O<D>	F5	GND	J21	I/O<C>	N15	VCC	U9	VCCIO<A>	AA3	GND
B12	I/O<D>	F6	VCC	J22	I/O<C>	N16	I/O	U10	NC	AA4	I/O<A>
B13	IOCTRL<D>	F7	VCCIO<D>	K1	CLKAN	N17	VCCIO	U11	VCCIO<A>	AA5	I/O<A>
B14	I/O<D>	F8	NC	K2	VCCREC	N18	I/O	U12	VCCIO<A>	AA6	I/O<A>
B15	I/O<D>	F9	VCCIO<D>	K3	VCCREC	N19	I/O	U13	NC	AA7	I/O<A>
B16	I/O<D>	F10	I/O<D>	K4	VCCPLL	N20	I/O	U14	VCCIO<A>	AA8	I/O<A>
B17	I/O<D>	F11	VCCIO<D>	K5	GND	N21	I/O	U15	NC	AA9	I/O<A>
B18	I/O<C>	F12	VCCIO<D>	K6	VCC	N22	I/O	U16	VCCIO<A>	AA10	I/O<A>
B19	PLLRST<0>	F13	I/O<D>	K7	VCC	P1	CH4N	U17	VCCIO	AA11	I/O<A>
B20	I/O<C>	F14	VCCIO<D>	K8	VCC	P2	VCCREC	U18	I/O	AA12	INREF<A>
B21	I/O<C>	F15	I/O<D>	K9	VCC	P3	VCCREC	U19	I/O	AA13	I/O<A>
B22	I/O<C>	F16	VCCIO<D>	K10	GND	P4	VCCPLL	U20	IOCTRL	AA14	I/O<A>
C1	CH0P	F17	I/O<C>	K11	GND	P5	GND	U21	I/O	AA15	I/O<A>
C2	VCCREC	F18	I/O<C>	K12	GND	P6	VCC	U22	INREF	AA16	I/O<A>
C3	GND	F19	I/O<C>	K13	GND	P7	VCC	V1	CH6N	AA17	I/O
C4	GND	F20	IOCTRL<C>	K14	VCC	P8	VCC	V2	VCCREC	AA18	I/O
C5	NC	F21	I/O<C>	K15	VCC	P9	GND	V3	VCCREC	AA19	I/O
C6	I/O<D>	F22	IOCTRL<C>	K16	NC	P10	VCC	V4	VCCPLL	AA20	GNDPLL<1>
C7	I/O<D>	G1	CH2P	K17	I/O<C>	P11	GND	V5	GND	AA21	I/O
C8	I/O<D>	G2	VCCREC	K18	I/O<C>	P12	VCC	V6	NC	AA22	I/O

(Sheet 1 of 2)

Table 44: 484 PBGA Pinout Table

Pin	Function	Pin	Function	Pin	Function	Pin	Function	Pin	Function	Pin	Function
C9	I/O<D>	G3	VCCREC	K19	I/O<C>	P13	VCC	V7	CLK<2>/PLL IN<2>	AB1	GND
C10	I/O<D>	G4	GNDPLL	K20	I/O<C>	P14	GND	V8	NC	AB2	VCC
C11	I/O<D>	G5	GND	K21	I/O<C>	P15	VCC	V9	I/O<A>	AB3	I/O<A>
C12	INREF<D>	G6	VCC	K22	I/O<C>	P16	I/O	V10	I/O<A>	AB4	I/O<A>
C13	I/O<D>	G7	GND	L1	CLKAP	P17	I/O	V11	I/O<A>	AB5	I/O<A>
C14	I/O<D>	G8	NC	L2	VCCREC	P18	I/O	V12	I/O<A>	AB6	I/O<A>
C15	I/O<D>	G9	CLK<0>	L3	VCCREC	P19	I/O	V13	I/O<A>	AB7	I/O<A>
C16	I/O<D>	G10	NC	L4	GNDPLL	P20	I/O	V14	I/O<A>	AB8	I/O<A>
C17	I/O<C>	G11	NC	L5	GND	P21	I/O	V15	I/O<A>	AB9	I/O<A>
C18	I/O<C>	G12	GND	L6	VCC	P22	I/O	V16	I/O	AB10	I/O<A>
C19	I/O<C>	G13	NC	L7	GND	R1	CH4P	V17	NC	AB11	I/O<A>
C20	GNDPLL <0>	G14	NC	L8	GND	R2	VCCREC	V18	NC	AB12	I/O<A>
C21	I/O<C>	G15	I/O<C>	L9	GND	R3	VCCREC	V19	I/O	AB13	I/O<A>
C22	I/O<C>	G16	GND	L10	GND	R4	GNDPLL	V20	I/O	AB14	I/O<A>
D1	CH1N	G17	VCCIO<C>	L11	GND	R5	GND	V21	I/O	AB15	I/O<A>
D2	VCCREC	G18	I/O<C>	L12	GND	R6	VCC	V22	I/O	AB16	I/O<A>
D3	VCCREC	G19	I/O<C>	L13	GND	R7	VCC	W1	CH6P	AB17	I/O<A>
D4	VCCPLL	G20	I/O<C>	L14	VCC	R8	GND	W2	VCCREC	AB18	I/O
D5	NC	G21	INREF<C>	L15	VCC	R9	VCC	W3	VCCREC	AB19	I/O
D6	NC	G22	I/O<C>	L16	CLK<6>	R10	VCC	W4	GNDPLL	AB20	GND
D7	VCC	H1	CH3N	L17	VCCIO<C>	R11	GND	W5	NC	AB21	VCCPLL<1>
D8	TCK	H2	VCCREC	L18	I/O<C>	R12	VCC	W6	TRSTB	AB22	I/O
D9	I/O<D>	H3	VCCREC	L19	CLK<8>	R13	VCC	W7	CLK<3>/PLL IN<1>		
D10	I/O<D>	H4	VCCPLL	L20	I/O<C>	R14	VCC	W8	CLK<4> DEDCLK/PL LIN<0>		
D11	I/O<D>	H5	GND	L21	I/O<C>	R15	GND	W9	I/O<A>		
D12	I/O<D>	H6	VCC	L22	I/O<C>	R16	NC	W10	I/O<A>		
D13	I/O<D>	H7	VCC	M1	CLKBN	R17	VCCIO	W11	I/O<A>		
D14	I/O<D>	H8	GND	M2	VCCREC	R18	I/O	W12	I/O<A>		
D15	I/O<D>	H9	VCC	M3	VCCREC	R19	I/O	W13	I/O<A>		
D16	I/O<D>	H10	VCC	M4	VCCPLL	R20	I/O	W14	I/O<A>		

(Sheet 2 of 2)

516 PBGA Pinout Diagram

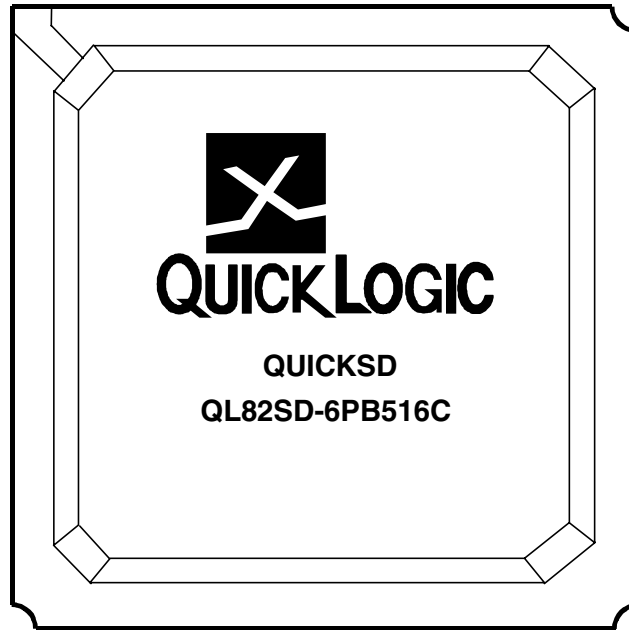

Figure 61: QL82SD - 516PBGA Top View

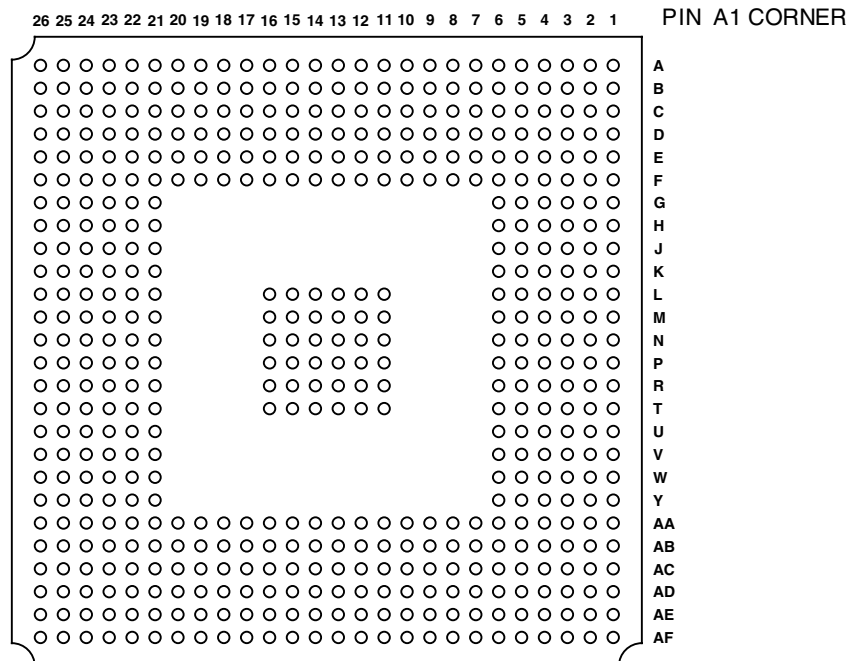

Figure 62: QL82SD - 516PBGA Bottom View

516 PBGA Pinout Table

Table 45: 516 PBGA Pinout Table

Pin	Function	Pin	Function	Pin	Function	Pin	Function	Pin	Function	Pin	Function
A01	NC	D09	IO(C)	H05	IO(C)	P01	IO(D)	W23	IO(A)	AC19	GNDPLL
A02	IO(C)	D10	IO(C)	H06	VCC	P02	IOCTRL(D)	W24	IO(A)	AC20	VCCPLL
A03	IO(C)	D11	IO(C)	H21	VCC	P03	INREF(D)	W25	IO(A)	AC21	GNDPLL
A04	IOCTRL(C)	D12	IO(C)	H22	VCC	P04	IOCTRL(D)	W26	IO(A)	AC22	GND
A05	IO(C)	D13	IO(C)	H23	PLLST(1)	P05	IO(D)	Y01	IO(D)	AC23	NC
A06	IO(C)	D14	CLK(5)	H24	GND	P06	VCCIO(D)	Y02	IO(D)	AC24	GND
A07	IO(C)	D15	IO(B)	H25	IO(B)	P11	GND	Y03	IO(D)	AC25	IO(A)
A08	IO(C)	D16	IO(B)	H26	IO(B)	P12	GND	Y04	IO(D)	AC26	IO(A)
A09	IO(C)	D17	IO(B)	J01	IO(D)	P13	GND	Y05	CLK(1)	AD01	IO(D)
A10	IO(C)	D18	IO(B)	J02	IO(D)	P14	GND	Y06	VCCIO(D)	AD02	TDI
A11	IO(C)	D19	IO(B)	J03	IO(C)	P15	GND	Y21	VCCIO(A)	AD03	GND
A12	IO(C)	D20	IO(B)	J04	IO(C)	P16	GND	Y22	CLK(4)DED CLK, PLLIN(0)	AD04	VCCREC
A13	TMS	D21	IO(B)	J05	IO(C)	P21	VCCIO(A)	Y23	IO(A)	AD05	VCCREC
A14	CLK(8)	D22	IO(B)	J06	VCCIO(D)	P22	IOCTRL(A)	Y24	IO(A)	AD06	VCCREC
A15	IO(B)	D23	IO(B)	J21	VCCIO(A)	P23	IO(A)	Y25	IO(A)	AD07	VCCREC
A16	IO(B)	D24	IO(B)	J22	PLLOUT(0)	P24	IOCTRL(A)	Y26	IO(A)	AD08	VCCREC
A17	IO(B)	D25	IO(B)	J23	IO(B)	P25	IO(A)	AA01	IO(D)	AD09	VCCREC
A18	IO(B)	D26	IO(B)	J24	IO(B)	P26	NC	AA02	IO(D)	AD10	VCCREC
A19	IO(B)	E01	IO(C)	J25	IO(B)	R01	IO(D)	AA03	IO(D)	AD11	VCCREC
A20	IO(B)	E02	IO(C)	J26	IO(A)	R02	IO(D)	AA04	CLK(0)	AD12	VCCREC
A21	IO(B)	E03	IO(C)	K01	IO(D)	R03	IO(D)	AA05	GND	AD13	VCCREC
A22	IO(B)	E04	IO(C)	K02	IO(D)	R04	IO(D)	AA06	GND	AD14	VCCREC
A23	IOCTRL(B)	E05	IO(C)	K03	IO(D)	R05	VCC	AA07	VCC	AD15	VCCREC
A24	IO(B)	E06	IO(C)	K04	IO(D)	R06	VCC	AA08	VCC	AD16	VCCREC
A25	IO(B)	E07	INREF(C)	K05	IO(C)	R11	GND	AA09	VCC	AD17	VCCREC
A26	IO(B)	E08	VCC	K06	GND	R12	GND	AA10	VCC	AD18	VCCREC
B01	IO(C)	E09	IO(C)	K21	GND	R13	GND	AA11	VCC	AD19	VCCREC
B02	IO(C)	E10	IO(C)	K22	IO(B)	R14	GND	AA12	VCC	AD20	VCCREC
B03	IO(C)	E11	IO(C)	K23	IO(B)	R15	GND	AA13	VCC	AD21	VCCREC
B04	IO(C)	E12	VCC	K24	IO(B)	R16	GND	AA14	VCC	AD22	VCCREC
B05	IO(C)	E13	IO(C)	K25	IO(A)	R21	VCC	AA15	VCC	AD23	VCCREC
B06	IO(C)	E14	IO(B)	K26	IO(A)	R22	IO(A)	AA16	VCC	AD24	GND
B07	IO(C)	E15	IO(B)	L01	IO(D)	R23	IO(A)	AA17	VCC	AD25	CLK(2)
B08	IO(C)	E16	VCC	L02	IO(D)	R24	IO(A)	AA18	VCC	AD26	IO(A)
B09	IO(C)	E17	IO(B)	L03	IO(D)	R25	IO(A)	AA19	VCC	AE01	TCK
B10	IO(C)	E18	IO(B)	L04	IO(D)	R26	INREF(A)	AA20	VCC	AE02	TDO
B11	IO(C)	E19	IO(B)	L05	VCC	T01	IO(D)	AA21	GND	AE03	GND
B12	IO(C)	E20	IO(B)	L06	VCC	T02	IO(D)	AA22	VCC	AE04	VCCREC
B13	IO(C)	E21	IO(B)	L11	GND	T03	IO(D)	AA23	IO(A)	AE05	VCCREC
B14	CLK(7)	E22	IO(B)	L12	GND	T04	IO(D)	AA24	IO(A)	AE06	VCCREC
B15	IO(B)	E23	IO(B)	L13	GND	T05	IO(D)	AA25	IO(A)	AE07	VCCREC
B16	IO(B)	E24	IO(B)	L14	GND	T06	VCC	AA26	IO(A)	AE08	VCCREC
B17	IO(B)	E25	IO(B)	L15	GND	T11	GND	AB01	IO(D)	AE09	VCCREC
B18	IO(B)	E26	IO(B)	L16	GND	T12	GND	AB02	IO(D)	AE10	VCCREC
B19	IO(B)	F01	VCCPLL(0)	L21	VCC	T13	GND	AB03	NC	AE11	VCCREC
B20	IO(B)	F02	GNDPLL(0)	L22	IO(A)	T14	GND	AB04	VCC	AE12	VCCREC
B21	NC	F03	IO(C)	L23	IO(A)	T15	GND	AB05	GND	AE13	VCCREC
B22	INREF(B)	F04	IO(C)	L24	IO(A)	T16	GND	AB06	GND	AE14	VCCREC
B23	IO(B)	F05	IO(C)	L25	IO(A)	T21	VCC	AB07	GND	AE15	VCCREC
B24	IO(B)	F06	GND	L26	IO(A)	T22	VCC	AB08	GND	AE16	VCCREC
B25	IO(B)	F07	VCCIO(C)	M01	IO(D)	T23	IO(A)	AB09	GND	AE17	VCCREC
B26	IO(B)	F08	VCC	M02	NC	T24	IO(A)	AB10	GND	AE18	VCCREC
C01	IO(C)	F09	VCCIO(C)	M03	IO(D)	T25	IO(A)	AB11	GND	AE19	VCCREC
C02	IO(C)	F10	GND	M04	IO(D)	T26	IO(A)	AB12	GND	AE20	VCCREC

(Sheet 1 of 2)

Table 45: 516 PBGA Pinout Table

Pin	Function	Pin	Function	Pin	Function	Pin	Function	Pin	Function	Pin	Function
C03	IO(C)	F11	VCC	M05	IO(D)	U01	IO(D)	AB13	GND	AE21	VCCREC
C04	IO(C)	F12	VCCIO(C)	M06	VCCIO(D)	U02	IO(D)	AB14	GND	AE22	VCCREC
C05	IOCTRL(C)	F13	GND	M11	GND	U03	IO(D)	AB15	GND	AE23	VCCREC
C06	IO(C)	F14	VCCIO(B)	M12	GND	U04	IO(D)	AB16	GND	AE24	GND
C07	IO(C)	F15	VCC	M13	GND	U05	IO(D)	AB17	GND	AE25	GND
C08	IO(C)	F16	VCC	M14	GND	U06	GND	AB18	GND	AE26	CLK(3)PLL1 N(1)
C09	IO(C)	F17	GND	M15	GND	U21	GND	AB19	GND	AF01	NC
C10	IO(C)	F18	VCCIO(B)	M16	GND	U22	IO(A)	AB20	GND	AF02	NC
C11	IO(C)	F19	VCC	M21	VCCIO(A)	U23	IO(A)	AB21	GND	AF03	GND
C12	IO(C)	F20	VCCIO(B)	M22	VCC	U24	IO(A)	AB22	GND	AF04	Ch0N
C13	IO(C)	F21	GND	M23	IO(A)	U25	IO(A)	AB23	TRSTB	AF05	Ch0P
C14	CLK(6)	F22	IO(B)	M24	IO(A)	U26	IO(A)	AB24	IO(A)	AF06	Ch1N
C15	IO(B)	F23	IO(B)	M25	IO(A)	V01	NC	AB25	IO(A)	AF07	Ch1P
C16	IO(B)	F24	IO(B)	M26	IO(A)	V02	IO(D)	AB26	NC	AF08	Ch2N
C17	IO(B)	F25	IO(B)	N01	IO(D)	V03	IO(D)	AC01	IO(D)	AF09	Ch2P
C18	IO(B)	F26	VCCPLL(1)	N02	IO(D)	V04	IO(D)	AC02	IO(D)	AF10	Ch3N
C19	IO(B)	G01	IO(C)	N03	IO(D)	V05	IO(D)	AC03	NC	AF11	Ch3P
C20	IO(B)	G02	GND	N04	IO(D)	V06	VCCIO(D)	AC04	GND	AF12	ClkAN
C21	IOCTRL(B)	G03	PLL0UT(1)	N05	IO(D)	V21	VCCIO(A)	AC05	GND	AF13	ClkAP
C22	IO(B)	G04	IO(C)	N06	GND	V22	IO(A)	AC06	VCCPLL	AF14	ClkBN
C23	IO(B)	G05	IO(C)	N11	GND	V23	IO(A)	AC07	GNDPLL	AF15	ClkBP
C24	IO(B)	G06	VCCIO(D)	N12	GND	V24	NC	AC08	VCCPLL	AF16	Ch4N
C25	IO(B)	G21	VCCIO(A)	N13	GND	V25	IO(A)	AC09	GNDPLL	AF17	Ch4P
C26	IO(B)	G22	IO(B)	N14	GND	V26	IO(A)	AC10	VCCPLL	AF18	Ch5N
D01	IO(C)	G23	IO(B)	N15	GND	W01	IO(D)	AC11	GNDPLL	AF19	Ch5P
D02	IO(C)	G24	IO(B)	N16	GND	W02	IO(D)	AC12	VCCPLL	AF20	Ch6N
D03	IO(C)	G25	IO(B)	N21	GND	W03	IO(D)	AC13	GNDPLL	AF21	Ch6P
D04	IO(C)	G26	GNDPLL(1)	N22	IO(A)	W04	NC	AC14	VCCPLL	AF22	Ch7N
D05	IO(C)	H01	IO(C)	N23	IO(A)	W05	VCC	AC15	GNDPLL	AF23	Ch7P
D06	IO(C)	H02	IO(C)	N24	IO(A)	W06	VCC	AC16	VCCPLL	AF24	NC
D07	IO(C)	H03	IO(C)	N25	IO(A)	W21	VCC	AC17	GNDPLL	AF25	NC
D08	IO(C)	H04	PLL0RST(0)	N26	IO(A)	W22	IO(A)	AC18	VCCPLL	AF26	NC

(Sheet 2 of 2)

Contact Information

Telephone: 408 990 4000 (US)
 416 497 8884 (Canada)
 44 1932 57 9011 (Europe)
 49 89 930 86 170 (Germany)
 852 8106 9091 (Asia)
 81 45 470 5525 (Japan)

E-mail: info@quicklogic.com
 Support: support@quicklogic.com
 Web site: <http://www.quicklogic.com/>

Revision History

Table 46: Revision History

Revision	Date	Originator and Comments
Rev. A - Preliminary	Sept. 2001	First Release - Paul Micallef and John Kim
Rev. B - Preliminary	Dec. 2001	Changes to diagrams and data - Paul Micallef and John Kim
Rev. C - Preliminary	June 2002	Updated performance figures - Paul Micallef and John Kim

Copyright Information

Copyright © 2002 QuickLogic Corporation. All Rights Reserved.

The information contained in this manual, and the accompanying software programs are protected by copyright—all rights are reserved by QuickLogic Corporation. QuickLogic Corporation reserves the right to make periodic modifications of this product without obligation to notify any person or entity of such revision. Copying, duplicating, selling, or otherwise distributing any part of this product without the prior written consent of an authorized representative of QuickLogic is prohibited.

QuickLogic[®], pASIC[®], and ViaLink[®] and QuickWorks[®] are registered trademarks of QuickLogic Corporation.

Verilog[®] is a registered trademark of Cadence Design Systems, Inc.

