

QM5HG-24

MEDIUM POWER SWITCHING USE
NON-INSULATED TYPE

QM5HG-24



- **IC** Collector current **5A**
- **V_{CEX}** Collector-emitter voltage **1200V**
- **h_{FE}** DC current gain **5**
- **Non-Insulated Type**

APPLICATION

Base driver for High voltage transistor modules

OUTLINE DRAWING & CIRCUIT DIAGRAM

Dimensions in mm

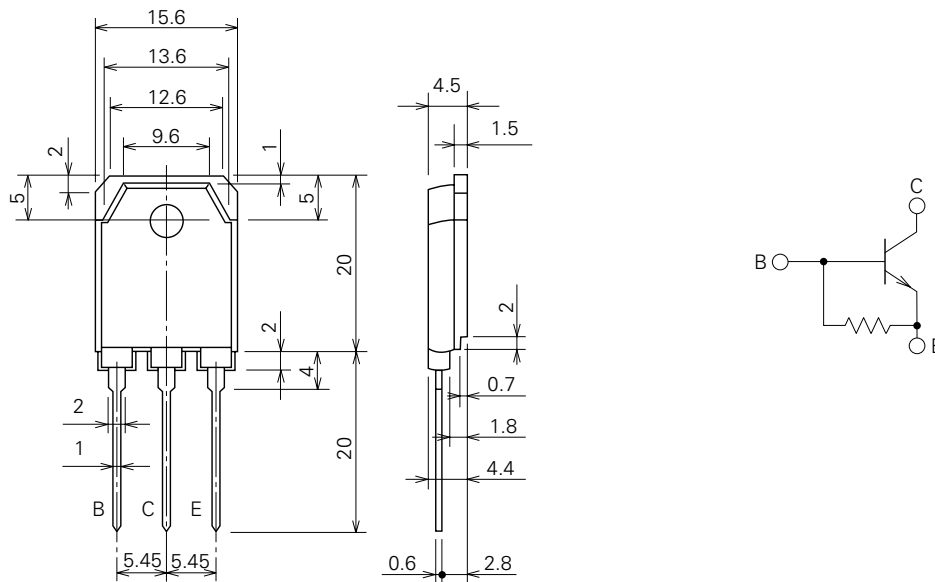

QM5HG-24

MEDIUM POWER SWITCHING USE
NON-INSULATED TYPE

ABSOLUTE MAXIMUM RATINGS (T_j=25°C, unless otherwise noted)

Symbol	Parameter	Conditions	Ratings	Unit
V _{CEX}	Collector-emitter voltage	V _{EB} =2V	1200	V
V _{CB0}	Collector-base voltage	Emitter open	1200	V
V _{EB0}	Emitter-base voltage	Collector open	7	V
I _C	Collector current	DC	5.0	A
P _C	Collector dissipation	T _C =25°C	100	W
I _B	Base current	DC	2	A
T _j	Junction temperature		-40~+150	°C
T _{stg}	Storage temperature		-40~+125	°C
—	Mounting torque	Mounting screw M3	0.59~0.98	N·m
—	Weight	Typical value	6~10	kg·cm
—	Weight	Typical value	5	g

ELECTRICAL CHARACTERISTICS (T_j=25°C, unless otherwise noted)

Symbol	Parameter	Test conditions	Limits			Unit
			Min.	Typ.	Max.	
I _{CX}	Collector cutoff current	V _{CE} =1200V, V _{EB} =2V	—	—	1.0	mA
I _{CB0}	Collector cutoff current	V _{CB} =1200V, Emitter open	—	—	1.0	mA
I _{EB0}	Emitter cutoff current	V _{EB} =7V	—	—	50	mA
V _{CE (sat)}	Collector-emitter saturation voltage	I _C =3A, I _B =0.6A	—	—	1.0	V
V _{BE (sat)}	Base-emitter saturation voltage		—	—	1.5	V
h _{FE}	DC current gain	I _C =3A, V _{CE} =1V	5	—	—	—
t _{on}	Switching time	V _{CC} =600V, I _C =3A, I _{B1} =0.6A, -I _{B2} =1.2A	—	—	1.0	μs
t _s			—	—	4.0	μs
t _f			—	—	0.8	μs
R _{th (j-c) Q}	Thermal resistance (junction to case)	Transistor part	—	—	1.25	°C/W
R _{th (j-c) R}		Diode part	—	—	—	°C/W
R _{th (c-f)}	Contact thermal resistance (case to fin)	Conductive grease applied	—	—	0.5	°C/W

QM5HG-24

MEDIUM POWER SWITCHING USE
NON-INSULATED TYPE

PERFORMANCE CURVES

COMMON EMITTER OUTPUT CHARACTERISTICS (TYPICAL)

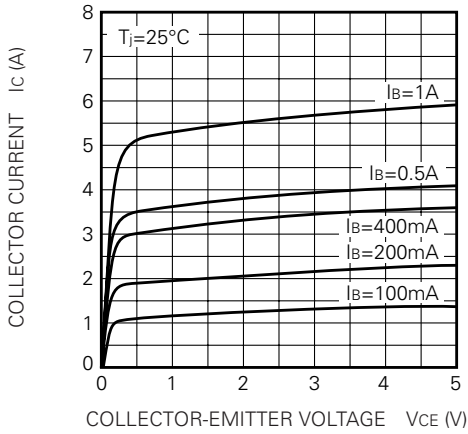

DC CURRENT GAIN VS. COLLECTOR CURRENT (TYPICAL)

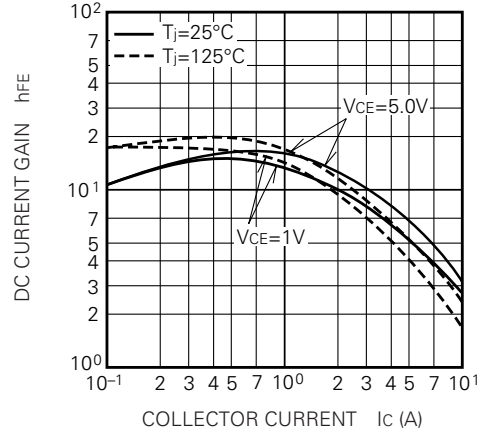

SATURATION VOLTAGE CHARACTERISTICS (TYPICAL)

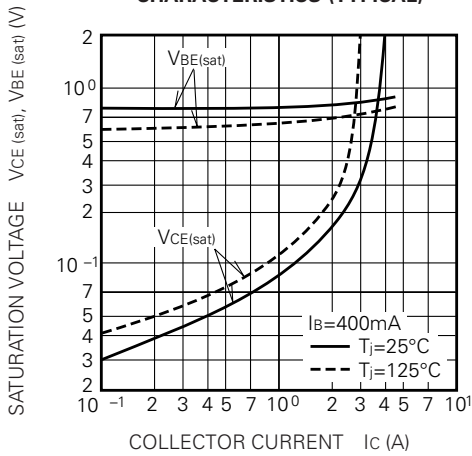

SWITCHING TIME VS. COLLECTOR CURRENT (TYPICAL)

