

Features

- 2:1 Wide Input Voltage Range
- 40 Watts Output Power
- 1.6kVDC Isolation
- Fixed Operating Frequency
- Six-Sided Continuous Shield
- Design Meet Safety Standard
- Standard 76.2 x66.0x10.2mm Package
- Efficiency to 90%

POWERLINE

DC/DC-Converter

RP40-S_D_TE Series

**40 Watt
Single, Dual,
Positive Dual &
Triple Output**



Selection Guide 12V, 24V and 48V Input Types

Part Number	Input Range VDC	Output Voltage VDC	Output Current mA	Input ⁽⁴⁾ Current mA	Efficiency ⁽⁵⁾ %	Capacitive ⁽⁶⁾ Load max. μF
RP40-123.3SE	9-18	3.3	10000	3530	85	25800
RP40-1205SE	9-18	5	8000	4170	87	13600
RP40-1212SE	9-18	12	3400	4100	88	2400
RP40-1215SE	9-18	15	2700	4100	88	1550
RP40-243.3SE	18-36	3.3	10000	1720	84	25800
RP40-2405SE	18-36	5	8000	2010	87	13600
RP40-2412SE	18-36	12	3400	1980	90	2400
RP40-2415SE	18-36	15	2700	2000	88	1550
RP40-483.3SE	36-75	3.3	10000	850	85	25800
RP40-4805SE	36-75	5	8000	980	89	13600
RP40-4812SE	36-75	12	3400	1000	89	2400
RP40-4815SE	36-75	15	2700	1000	88	1550
RP40-1205DE	9-18	±5	+7000 / -1000	4330	81	12000 / 1700
RP40-1212DE	9-18	±12	±1800	4550	83	±1200
RP40-1215DE	9-18	±15	±1400	4430	83	±750
RP40-2405DE	18-36	±5	+7000 / -1000	2130	82	12000 / 1700
RP40-2412DE	18-36	±12	±1800	2170	87	±1200
RP40-2415DE	18-36	±15	±1400	2140	86	±750
RP40-4805DE	36-75	±5	+7000 / -1000	1060	84	12000 / 1700
RP40-4812DE	36-75	±12	±1800	1100	86	±1200
RP40-4815DE	36-75	±15	±1400	1100	86	±750
RP40-123.305DE	9-18	3.3 / 5	4000 / 4000	3730	78	10300 / 6800
RP40-243.305DE	18-36	3.3 / 5	4000 / 4000	1840	79	10300 / 6800
RP40-483.305DE	36-75	3.3 / 5	4000 / 4000	910	80	10300 / 6800
RP40-120512TE	9-18	5 / ±12	4000 / ±850	4490	79	6800 / ±590
RP40-120515TE	9-18	5 / ±15	4000 / ±680	4430	80	6800 / ±380
RP40-240512TE	18-36	5 / ±12	4000 / ±850	2180	81	6800 / ±590
RP40-240515TE	18-36	5 / ±15	4000 / ±680	2160	82	6800 / ±380
RP40-480512TE	36-75	5 / ±12	4000 / ±850	1060	83	6800 / ±590
RP40-480515TE	36-75	5 / ±15	4000 / ±680	1060	83	6800 / ±380

RECOM

Derating-Graph (Ambient Temperature)

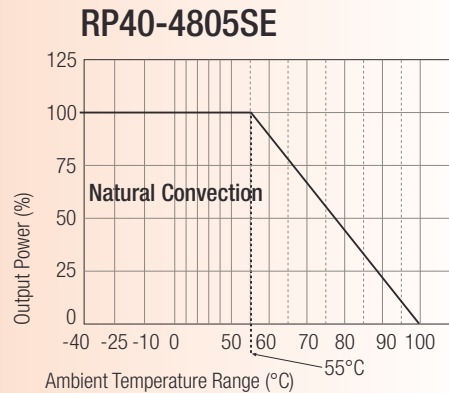

Derating graphs are valid only for the shown part numbers. If you need detailed derating-information about a part-number not shown here please contact our technical customer service at info@recom-development.at

Typical Characteristics

RP40-4805SE

Efficiency VS Input Voltage

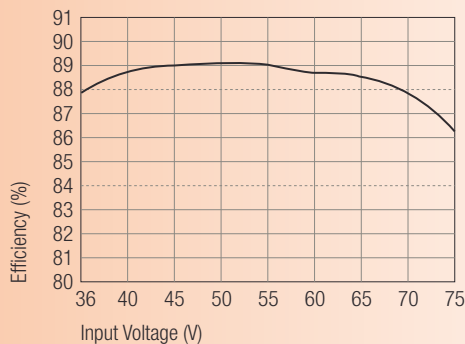

RP40-4805SE

Efficiency VS Output Load

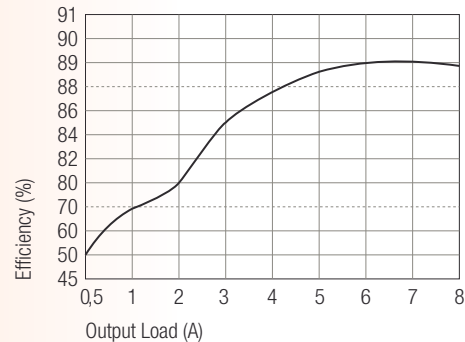

Specifications (typical at nominal input and 25°C unless otherwise noted)

Input Voltage Range	12V nominal input	9-18VDC
	24V nominal input	18-36VDC
	48V nominal input	36-75VDC
Input Filter		Pi Type
Input Surge Voltage (100 ms max.)	12V Input	36VDC
	24V Input	50VDC
	48V Input	100VDC
Input Reflected Ripple (nominal Vin and full load) (see Note 3)		40mAp-p
Start Up Time (nominal Vin and constant resistor load)		25ms typ.
Remote ON/OFF (see Note 7)	DC-DC ON	Open or 3.5V < Vr < 12V
	DC-DC OFF	Short or 0V < Vr < 1.2V
Remote OFF input current	Nominal input	30mA
Output Power		40W max.
Output Voltage Accuracy (full Load and nominal Vin)	Single & Dual	±2%
	Triple 3.3V, 5V	±2%
	Auxiliary	±5%

continued on next page

Specifications (typical at nominal input and 25°C unless otherwise noted)

Voltage Adjustability		±10%
Minimum Load (see Note 1)	RP40-xx3.305DE others	20% min. 10% of full load
Line Regulation (low line, high line at full load)	Single Dual Triple 3.3V, 5V Auxiliary	±0.5% ±1% ±2% ±5%
Load Regulation (25% to 100% full load)	Single Dual Triple 3.3V, 5V Auxiliary	±0.5% ±1% ±2% ±5%
Cross Regulation (see Note 8)	Dual Triple 3.3V, 5V Auxiliary	±1% ±1% ±5%
Ripple and Noise (20MHz bandwidth)		1%/p-p of Vout max.
Temperature Coefficient		±0.02%/°C max.
Transient Response (25% load step change)		500µs
Over Voltage Protection	3.3V	3.9V
Zener diode clamp (only single)	5V 12V 15V	6.2V 15V 18V
Short Circuit Protection		Hiccup, automatic recovery
Efficiency		see „Selection Guide“ table
Isolation Voltage		1600VDC min.
Isolation Resistance		1 GΩ min.
Isolation Capacitance		500pF max.
Operating Frequency		185kHz typ.
Operating Temperature Range		-40°C to +85°C(with derating)
Maximum Case Temperature		+100°C
Storage Temperature Range		-55°C to +105°C
Thermal Impedance	Natural convection	7.3°C/Watt
Thermal Shock		MIL-STD-810D
Vibration		10-55Hz, 2G, 30 Min. along X, Y and Z
Relative Humidity		5% to 95% RH
Case Material		Nickel plated copper
Base Material		Non-conductive black plastic FR4
Potting Material		Epoxy (UL94-V0)
Conducted Emissions (see Note 9)	EN55022	Level A
Radiated Emissions	EN55022	Level A
ESD	EN61000-4-2	Perf. Criteria 2
Radiated Immunity	EN61000-4-3	Perf. Criteria 2
Fast Transient	EN61000-4-4	Perf. Criteria 2
Surge	EN61000-4-5	Perf. Criteria 2
Conducted Immunity	EN61000-4-6	Perf. Criteria 2
Weight		48g
Dimensions		76.2 x 66.0 x 10.2mm
MTBF (see Note 2)		1315 x 10 ³ hours

Notes :

1. The RP40 series required a minimum 10% loading on the output to maintain specified regulation. Operation under no-load condition will not damage these devices, however they may not meet all listed specification.
2. BELLCORE TR-NWT-000332. Case I: 50% Stress, Temperature at 40°C (Ground fixed and controlled environment).
3. Simulated source impedance of 12μH. 12μH inductor in series with +Vin.
4. Maximum value at nominal input voltage and full load of standard type.
5. Typical value at nominal input voltage and full load.
6. Test by minimum Vin and constant resistor load.
7. The ON/OFF control pin voltage is referenced to negative input
8. Cross regulation:
Dual output—Asymmetrical load 25% to 100% full load
Triple output – 3.3V / 5V 100% load and one of auxiliary 100% load, other auxiliary load change from 25% to 100% load
9. See application notes for EMI-filtering.

Package Style and Pinning (mm)

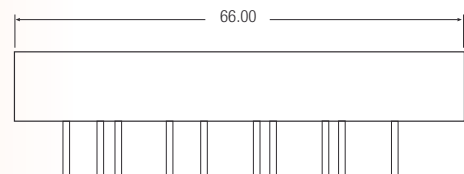
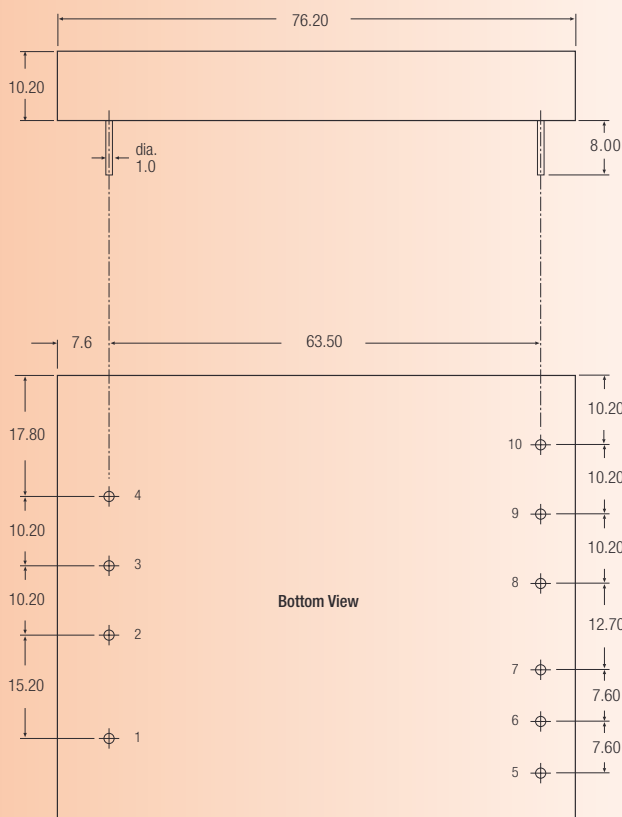

Pin Connections

Pin #	Single	Dual	Triple	3.3V / 5V
1	CTRL	CTRL	CTRL	CTRL
2	+Vin	+Vin	+Vin	+Vin
3	-Vin	-Vin	-Vin	-Vin
4	SYNC	SYNC	SYNC	SYNC
5	Trim Down	+Vout	+Aux	3.3V
6	Trim	Com	Com (Aux)	Com
7	Trim Up	-Vout	-Aux	+5V
8	+Vout	Trim	+Vout(Primary)	Trim
9	-Vout	NC	Com(Primary)	NC
10	No Pin	NC	Trim	NC

NC = No Connection

Pin Pitch Tolerance ±0.35 mm

Application of Synchronization

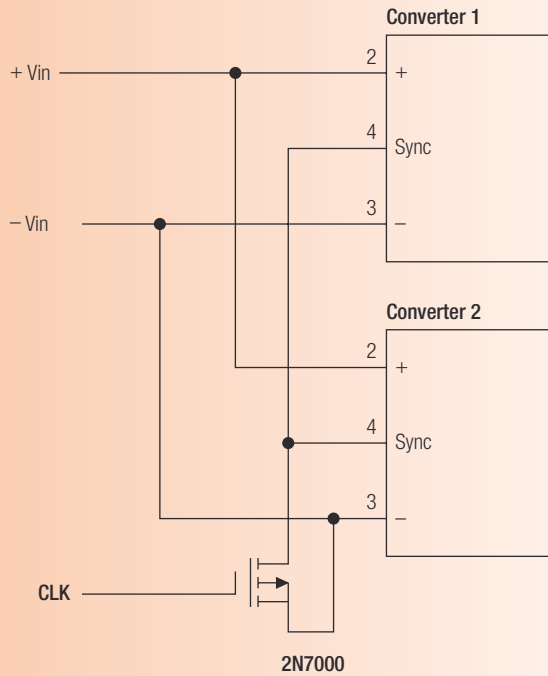

1. The unit is capable of external synchronization from an independent time base with a switching rate between 200kHz and 215 kHz.
2. The amplitude of the synchronizing pulse train is TTL compatible.
3. The duty cycle of the CLK should be 20% high and 80% low.
4. Synchronization is referenced to negative input (-Vin).

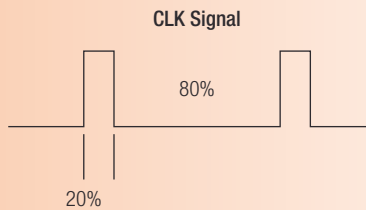
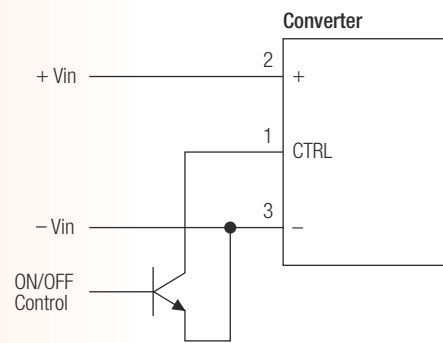

External Output Trimming

Output can be externally trimmed by using the method shown below.

- () for dual output trim
- [] for triple output trim
- { } for RP40-xx3.305DE only trim 3.3V / 5V

