

CONTENTS

Features	1
Selection Guide	1
Block Diagram	2
Pin Assignment	3
Functions of Pins	3
Absolute Maximum Ratings	3
Electrical Characteristics	4
Measurement Circuits	5
Operation	8
Operating Timing Chart	9
Battery Protection IC	10
Handling Precautions	10
Dimensions	11
Markings	11
Taping	12
Characteristics	13

The S-8491 is a series of lithium-ion rechargeable battery protection ICs incorporating high-accuracy voltage detectors and a delay circuit. This series is suitable for protecting a single-cell pack.

■ Features

(1) Built-in high-accuracy voltage detection circuits:

- ① Excess charge detection voltage V_{CU} .. 4.35 ± 0.05 V to 4.25 ± 0.05 V/0.05 V step
- ② Excess charge release voltage V_{CD} 4.15 ± 0.13 V to 3.95 ± 0.13 V/0.05 V step
 - * The difference between the excess charge detection voltage and the excess charge release voltage can be selected in the range of 0.2 V to 0.3 V.
- ③ Excess discharge detection voltage V_{DD} 2.30 ± 0.10 V
- ④ Excess discharge release voltage V_{DU} 3.00 ± 0.15 V to 2.40 ± 0.15 V/0.10 V step
- ⑤ Excess current detection voltage V_{IOV} 0.20 ± 0.06 V

(2) Built-in delay circuit

The excess charge, excess discharge or excess current is detected with delay.

(3) Ultra-low current consumption

Operation: 15.0 μ A max. (+ 25 °C)
 Power down: 0.48 μ A max. (+ 25 °C)

(4) SOT - 89 - 5 package

■ Selection Guide

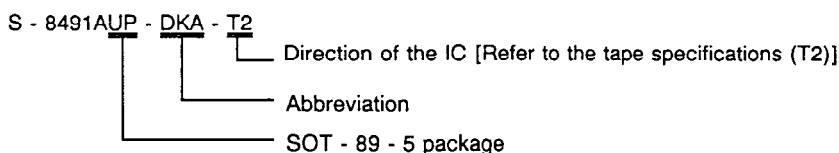

Table 1

Product	Item	Excess charge detection voltage	Excess charge release voltage	Excess discharge release voltage
S-8491AUP-DKA-T2		4.30 ± 0.05 V	4.00 ± 0.13 V	3.00 ± 0.15 V
S-8491BUP-DKB-T2		4.35 ± 0.05 V	4.10 ± 0.13 V	3.00 ± 0.15 V
S-8491CUP-DKC-T2		4.25 ± 0.05 V	4.05 ± 0.13 V	2.70 ± 0.15 V
S-8491DUP-DKD-T2		4.25 ± 0.05 V	4.05 ± 0.13 V	2.40 ± 0.15 V

Characteristics not specified in Table 1 apply commonly to the S-8491AUP/BUP/CUP/DUP.

■ Block Diagram

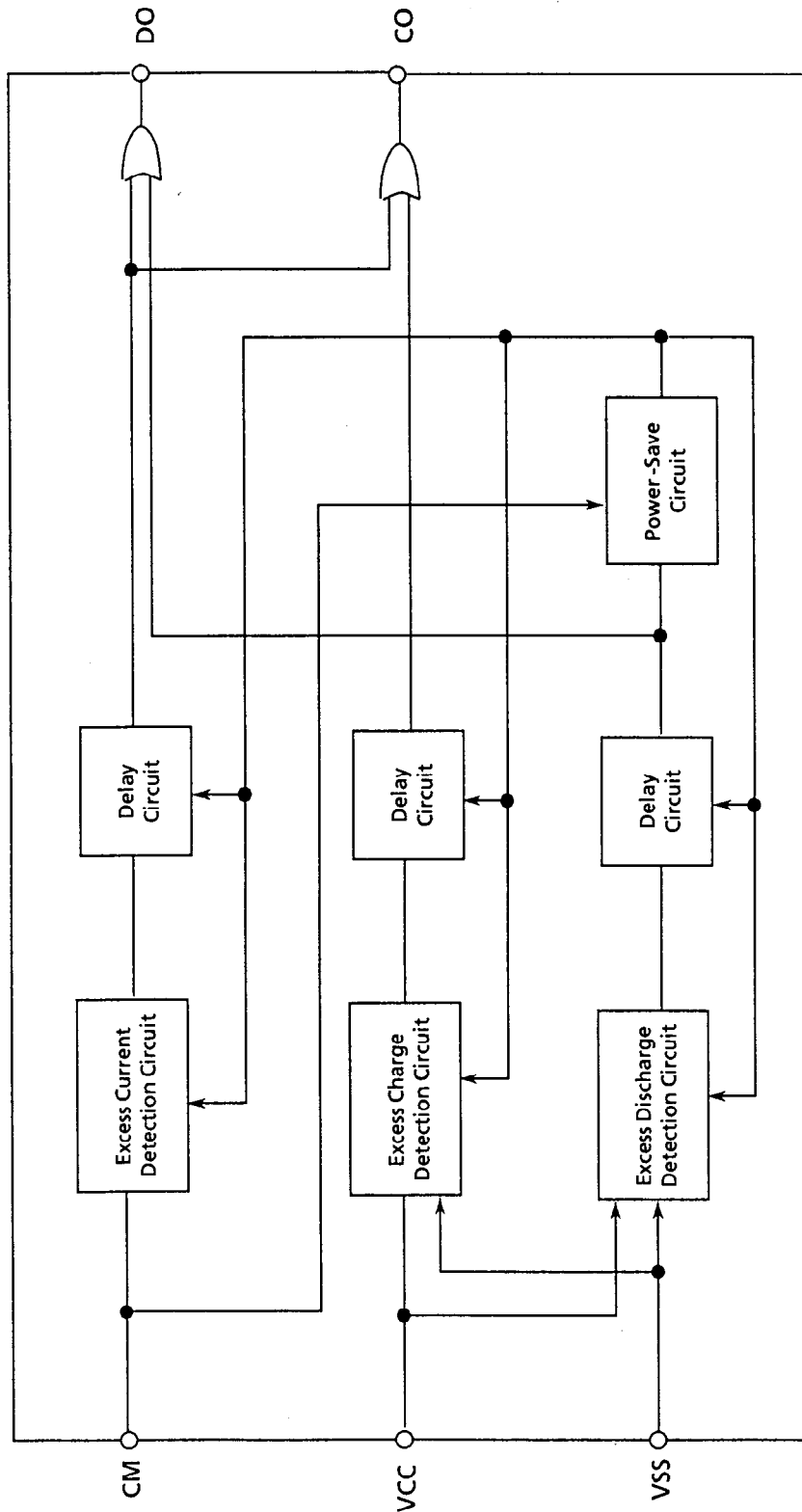

Figure 1

■ Pin Assignment

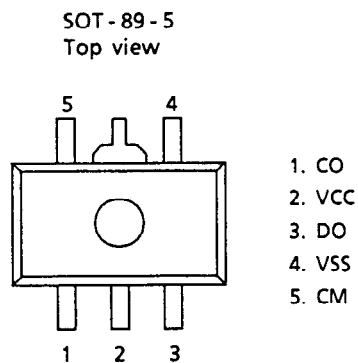

Figure 2

■ Functions of Pins

- V_{CC} (Pin No. 2) Input
Power supply pin at the positive side of the IC. :
- V_{SS} (Pin No. 4) Input
Power supply pin at the negative side of the IC.
- DO (Pin No. 3) Output (CMOS)
Gate connection pin for the discharge control Nch-FET. It turns OFF the gate during excess charge or excess current, whereas it turns ON the gate in the excess charge or the normal region.
- CO (Pin No. 1) Output (Pch open-drain)
Gate connection pin for the charge control Nch-FET. This pin turns ON the gate in the excess current region, whereas it turns ON the gate in the normal or excess discharge region.
- CM (Pin No. 5) Input
Voltage detection pin (between CM and V_{SS}). Detects the discharge current value of the battery due to a drop in the voltage of the FET.

■ Absolute Maximum Ratings

Table 2

Ta = 25°C

Item	Symbol	Ratings	Unit
Input voltage between V _{CC} - V _{SS}	V _{DS}	V _{SS} - 0.3 to + 18	V
Input voltage between V _{CC} - CM	V _{CM}	V _{CC} + 0.3 to - 18	
Input voltage between DO - V _{SS}	V _{DOS}	V _{SS} - 0.3 to V _{CC} + 0.3	V
Input voltage between V _{CC} - CO	V _{COB}	V _{CC} + 0.3 to -18	
Power dissipation	PD	500	mW
Operating temperature range	Topr	- 20 to + 60	°C
Storage temperature range	Tstg	- 40 to + 125	°C

■ **Electrical Characteristics**

Table 3

Ta = 25°C

Item	Symbol	Conditions	Min.	Typ.	Max.	Unit	
Excess charge detection voltage	V _{CU}	Measurement 1	AUP	4.25	4.30	4.35	V
			BUP	4.30	4.35	4.40	
			CUP	4.20	4.25	4.30	
			DUP	4.20	4.25	4.30	
Excess charge release voltage	V _{CD}	Measurement 1	AUP	3.87	4.00	4.13	
			BUP	3.97	4.10	4.23	
			CUP	3.92	4.05	4.18	
			DUP	3.92	4.05	4.18	
Excess discharge detection voltage	V _{DD}	Measurement 1	2.20	2.30	2.40		
Excess discharge release voltage	V _{DU}	Measurement 1	AUP	2.85	3.00	3.15	
			BUP	2.85	3.00	3.15	
			CUP	2.55	2.70	2.85	
			DUP	2.25	2.40	2.55	
Excess current detection voltage	V _{IOV}	Measurement 6	0.14	0.20	0.26		
Temperature coefficient of the detection voltage	T _{COE}	Ta = -20 to +60	-1.5	—	+1.5	mV/°C	
Delay time of excess charge detection	T _{CU}	Measurement 2	0.5	—	5.0	ms	
Delay time of excess discharge detection	T _{DD}	Measurement 2	0.5	—	5.0		
Delay time of excess current detection	T _{OFF}	Measurement 2	0.5	—	5.0		
Input voltage between V _{CC} and V _{SS}	V _{DS}	—	-0.3	—	16	V	
Input voltage between V _{CC} and CM	V _{CM}	Note 1	+0.3	—	-16		
Operating voltage between V _{CC} and V _{SS}	V _{DSOP}	—	2.0	—	16		
Normal operating current consumption	I _{OP}	Measurement 3	—	3.50	15	μA	
Power-down current consumption	I _{PDN}	Measurement 3	—	0.25	0.48		
DO 'H' voltage	V _{DO(H)}	Measurement 4	V _{CC} - 0.5	—	—	V	
DO 'L' voltage	V _{DO(L)}	Measurement 4	—	—	V _{SS} + 0.1		
CO 'H' voltage	V _{CO(H)}	Measurement 5	V _{CC} - 0.5	—	—		

Note 1: The V_{CC} pin-based voltage supplied to the CM pin.

Table 4

Ta = -20 to 60 °C

Item	Symbol	Conditions	Min.	Typ.	Max.	Unit
Temperature coefficient of detection voltage	T _{COE}	Ta = -20 to +60	-1.5	—	+1.5	mV/°C
Delay time of excess charge detection	T _{CU}	Measurement 2	0.5	—	5.0	ms
Delay time of excess discharge detection	T _{DD}	Measurement 2	0.5	—	5.0	
Delay time of excess current detection	T _{OFF}	Measurement 2	0.5	—	5.0	
Normal operating current consumption	I _{OP}	Measurement 3	—	3.50	20	μA
Power down current consumption	I _{PDN}	Measurement 3	—	0.25	0.58	
DO 'H' voltage	V _{DO(H)}	Measurement 4	V _{CC} - 0.5	—	—	V
DO 'L' voltage	V _{DO(L)}	Measurement 4	—	—	V _{SS} + 0.1	
CO 'H' voltage	V _{CO(H)}	Measurement 5	V _{CC} - 0.5	—	—	

■ Measurement Circuits

(1) Measurement 1

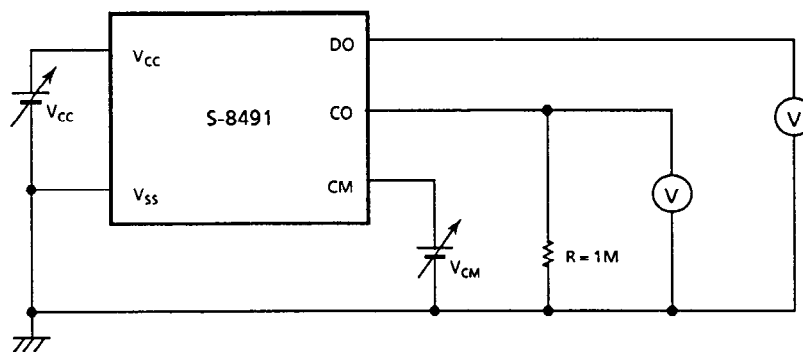

To measure excess charge detection voltage V_{CU}, excess charge release voltage V_{CD}, excess discharge detection voltage V_{DD}, and excess discharge release voltage V_{DU}, follow these steps:

- ① In the normal region with V_{CC} = V_{CD}, V_{CM} = 0 V, excess charge detection voltage V_{CU} is the voltage of V_{CC} when CO goes low after gradually increasing V_{CC}.
- ② In the excess charge region with V_{CC} = V_{CU} + 0.1 V, V_{CM} = 0 V, excess charge release voltage V_{CD} is the voltage of V_{CC} when CO goes high after gradually increasing V_{CC}.
- ③ In the normal region with V_{CC} = V_{CD}, V_{CM} = 0 V, excess discharge detection voltage V_{DD} is the voltage of V_{CC} when DO goes low after gradually decreasing V_{CC}.
- ④ In the excess discharge region with V_{CC} = 2.0 V, V_{CM} = 0 V, excess discharge release voltage V_{DU} is the voltage of V_{CC} when DO goes high after gradually increasing V_{CC}.

Note: Rise and fall speeds of V_{CC} are each specified at 150 V/sec or less.

(2) Measurement 2

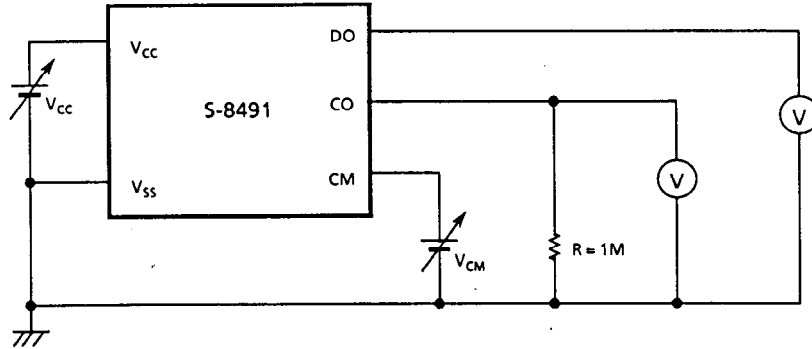

To measure excess charge detection time T_{CU} , excess discharge detection time T_{DD} , and excess current detection time T_{OFF} , follow these steps:

- ① In the normal region with $V_{CC} = V_{CU} - 0.1$ V, $V_{CM} = 0$ V, excess charge detection time T_{CU} is the time from when V_{CC} is $V_{CU} + 0.1$ V to when CO goes low.
- ② In the normal region with $V_{CC} = V_{DD} + 0.1$ V, $V_{CM} = 0$ V, excess discharge detection time T_{DD} is the time from when $V_{CC} = V_{DD} - 0.1$ V to when DO goes low.
- ③ In the normal region with $V_{CC} = 3.5$ V, $V_{CM} = 0$ V, excess current detection time T_{OFF} is the time from when V_{CM} is 3.5 V to when DO goes low.

(3) Measurement 3

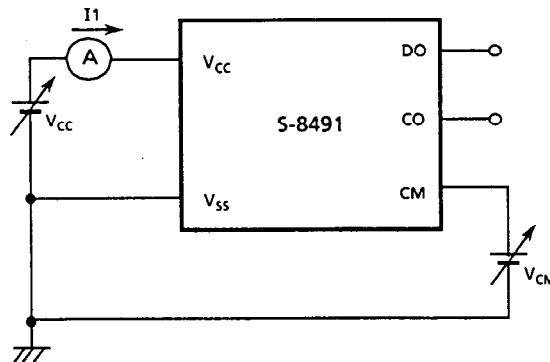

- ① In the normal region with $V_{CC} = 3.5$ V, $V_{CM} = 0$ V, normal operating current consumption I_{OPE} is I_1 .
- ② In the excess discharge region with $V_{CC} = 2.0$ V, $V_{CM} = 2.0$ V, current consumption I_{PDN} in power-down mode is I_1 .

(4) Measurement 4

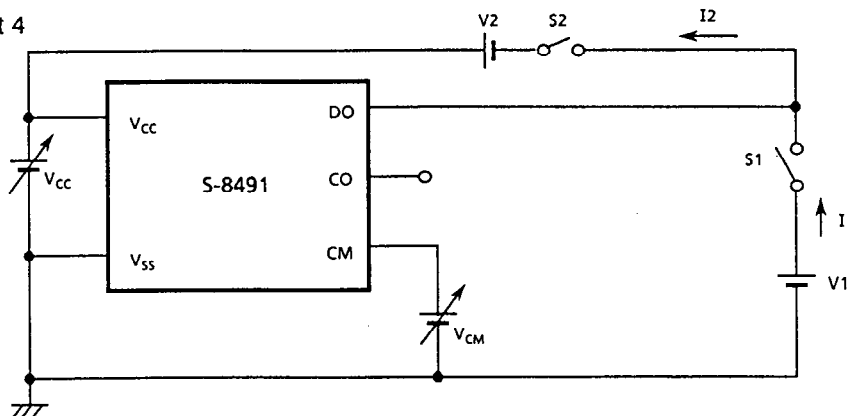

To measure DO 'H' voltage $V_{DO(H)}$, DO 'L' voltage $V_{DO(L)}$, follow these steps:

- ① In the normal region with $V_{CC} = 3.5$ V, $V_{CM} = 0$ V, $S_1 = \text{open}$, $S_2 = \text{close}$, $V_2 = 0$ V, DO 'H' voltage $V_{DO(H)}$ is the voltage of V_2 when I_2 is $10 \mu\text{A}$ after gradually increasing V_2 .
- ② In the excess current region with $V_{CC} = 3.5$ V, $V_{CM} = 3.5$ V, $S_1 = \text{close}$, $S_2 = \text{open}$, $V_1 = 0$ V, DO 'L' voltage $V_{DO(L)}$ is the voltage of V_1 when $I_1 = 10 \mu\text{A}$ after gradually increasing V_1 .

(5) Measurement 5

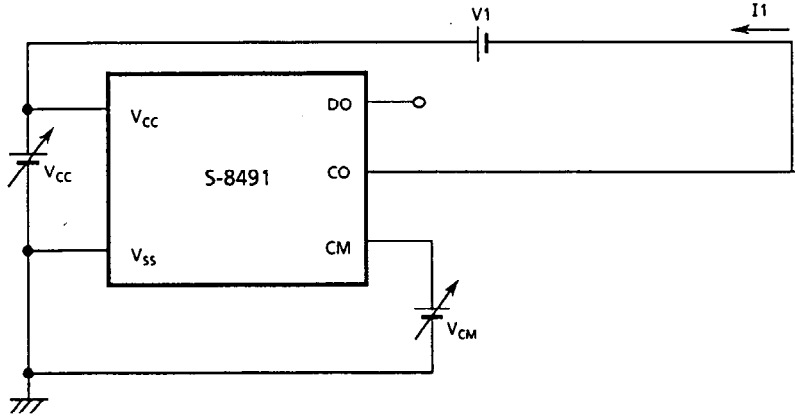

To measure CO 'H' voltage $V_{CO(H)}$, follow the step:

- ① In the normal region with $V_{CC} = 3.5\text{ V}$, $V_{CM} = 0\text{ V}$, $V1 = 0\text{ V}$, CO 'H' voltage $V_{CO(H)}$ is the voltage of V1 when $I1 = 10\ \mu\text{A}$ after gradually increasing V1.

(6) Measurement 6

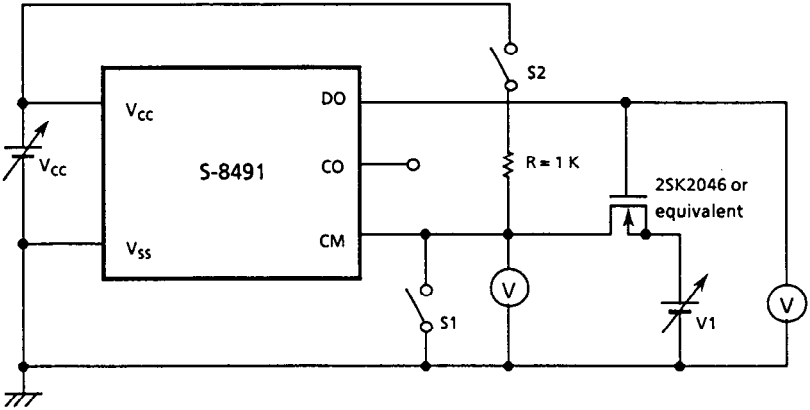

To measure excess current detection voltage V_{IOV} , follow the step:

- ① In the normal region with $V_{CC} = 3.5\text{ V}$, $V1 = 0\text{ V}$, $S1 = \text{close}$ $S2 = \text{close}$, **excess current detection voltage V_{IOV}** is the voltage of the CM pin when DO goes low after opening S1 and after gradually increasing V1.

■ **Operation**

Normal

This IC monitors both the voltage and the current of a battery connected between V_{CC} and V_{SS} , and controls charge and discharge. When the voltage of the battery is over V_{DD} , and below V_{CU} , and the voltage of the CM pin is below V_{IOV} , this IC turns ON the charge and discharge FETs. This is called the normal region.

Excess Charge

In the normal region, when the voltage of the battery being charged exceeds V_{CU} , this IC stops charge by turning OFF the charge FET. This is called the excess charge region. When the battery voltage goes below V_{CD} , the state returns to the normal.

Excess Discharge

In the normal region, when the voltage of the battery being discharged goes below V_{DU} , this IC stops discharge by turning OFF the discharge FET. Current consumption of the IC turns to I_{PDN} at this time. This is called the excess discharge region.

When a charger is connected in the excess discharge region and the battery voltage exceeds V_{DU} , the state returns to the normal.

Excess Current

In the normal region, when the voltage of the CM pin exceeds V_{IOV} during discharge, this IC stops discharge by turning OFF the discharge FET. This is called excess current.

The state is returned to the normal by being more than $500M\Omega$ resistance between EB+ and EB-, for example, by removing load.

Delay Circuit

This IC is provided with a comparator for monitoring excess charge detection, excess discharge detection or excess current. Also, it has delay time from when the comparator detects the voltage to when the output voltage is inverted at DO and CO pins.

Delay occurs only during the following operations.

- (1) The "comparator" detects the excess charge detection voltage → Delay time → CO pin changes to the Hi-Z level.
- (2) The "comparator" detects the excess discharge detection voltage → Delay time → DO pin changes to the V_{SS} level.
- (3) The "comparator" detects the excess current detection voltage → Delay time → DO pin changes to the V_{SS} level.

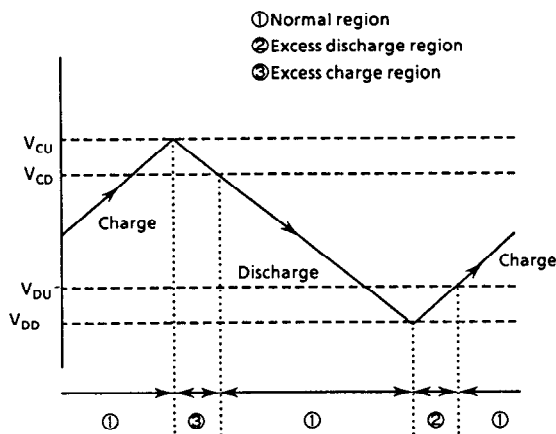

Figure 3

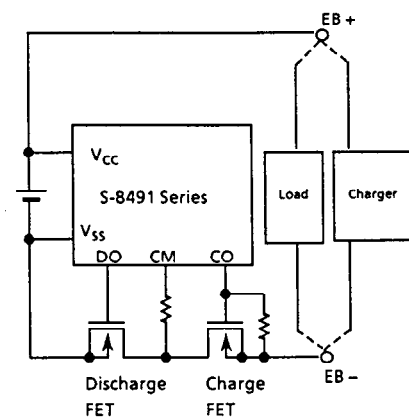

Figure 4

Table 5

Region	DO pin	CO pin
Normal → Charge → Excess charge	H	H → Delay → Hi-z
Excess charge → Discharge → Normal	H	Hi-z → H
Normal → Discharge → Excess discharge	H → Delay → L	H
Excess discharge → Charge → Normal	L → H	H
Excess charge → Excess current occurs	H → Delay → L	Hi-z
Normal region → Excess current occurs	H → Delay → L	H → Hi-z
Excess discharge → Load short	L	H

■ Operating Timing Charts

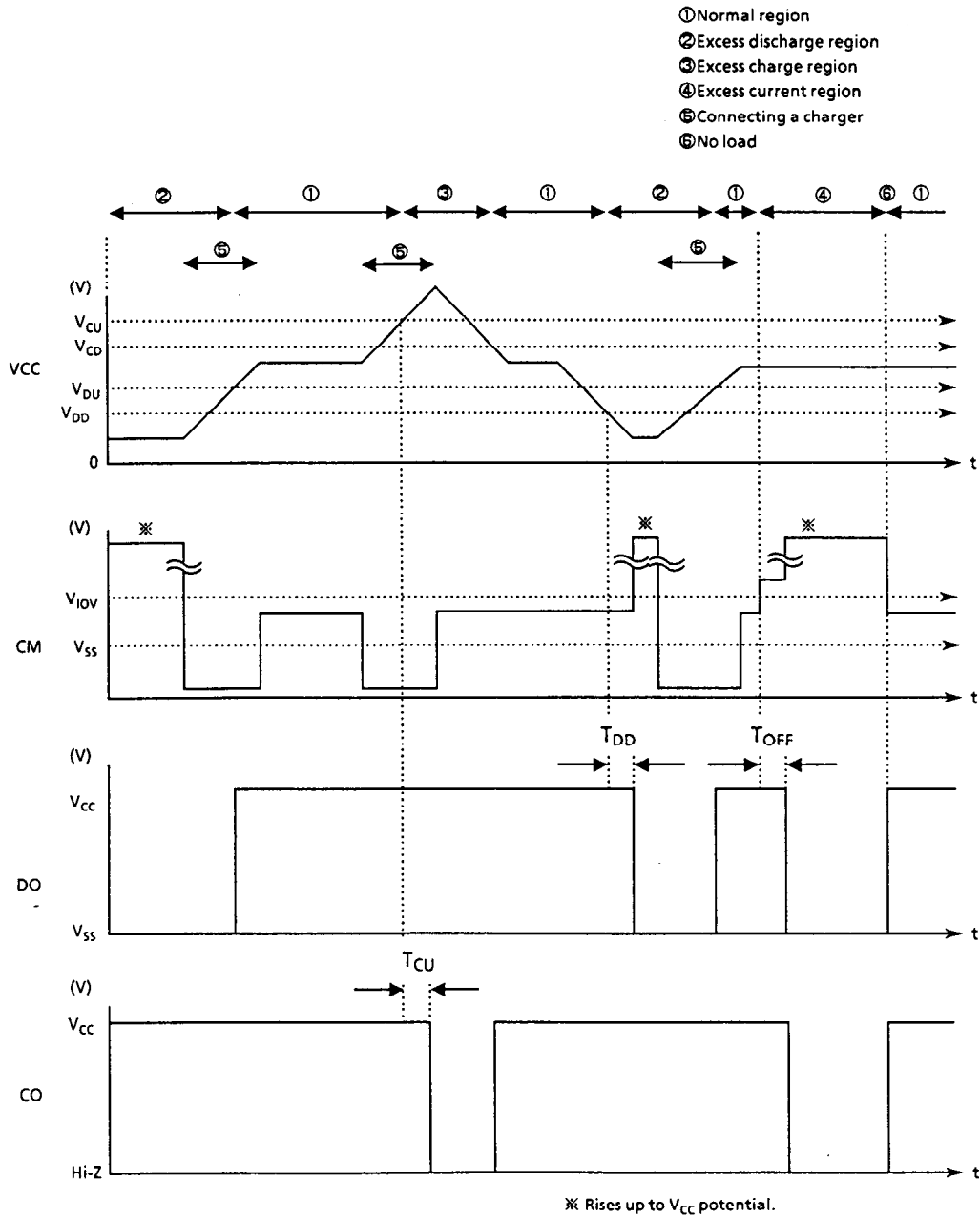

Figure 5

■ **Battery Protection IC Connection Diagram**

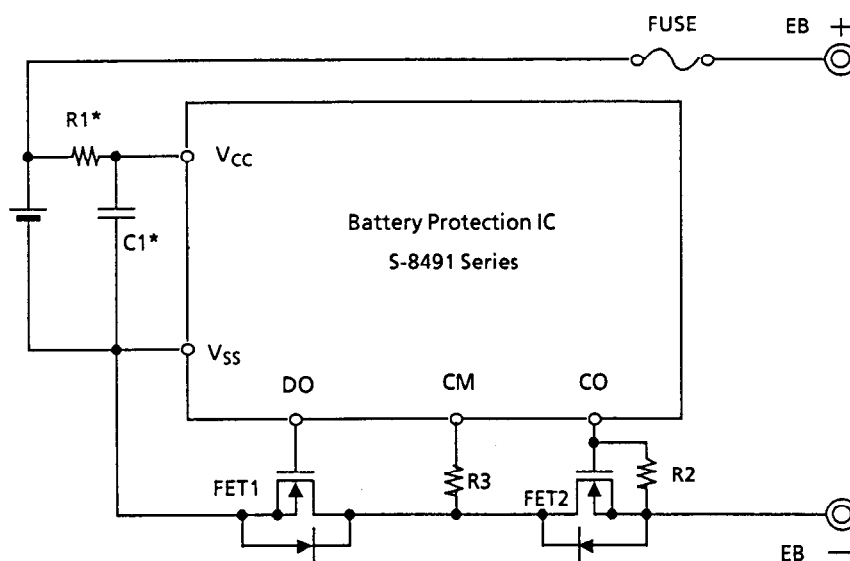

Figure 6

- Install an R1* less than 1 K Ω .
- The R2 is a pull-down resistor which turns OFF FET2. The R2 also protects the IC when the charger is connected reversely. Use a resistor from 100 K Ω or more to 1 M Ω or less.
- The R3 protects the IC when the charger is connected reversely. Use a resistor from 1 K Ω or more to 10 K Ω or less.
- Install a C1* more than 0.47 μ F.
- * if they are needed for ESD (Electric Static Discharge) protection.
- * The connection diagram explain typical applications of the products, and do not guarantee any massproduction design.

■ **Handling Precautions**

- In the excess discharge region, the voltage of the CM pin rises to the power supply voltage V_{CC} . This forces the built-in comparator to stop. Unless the CM pin is down to the V_{CC} level or less by connecting a charger, the excess discharge state can be retained.
- When initially connecting the battery to the IC, the state may go to the excess discharge state depending upon the characteristics of the capacitor or resistor attached to the CM pin. To return to the normal region, set the CM pin to the V_{SS} level or less (connect a charger).
- Oscillation may occur depending upon the value of the capacitor or resistor attached to the CM or DO pin. Select one from the following parts:
 - FET1 gate capacity: A capacitor of 5000 pF or less
 - Wiring resistance on the PCB between DO pin and FET1 gate: A resistor of 5 Ω or less
 - (Refer to Figure 4, Battery Protection IC Diagram)
- When the excess current generates, the battery voltage drops due to its internal impedance to stop discharge. If the voltage goes below the operating voltage of the IC (2.0 V), the excess discharge state may be retained even when the load is released. To return to the normal region, set the CM pin to the V_{SS} or less (connect a charger).

■ Dimensions

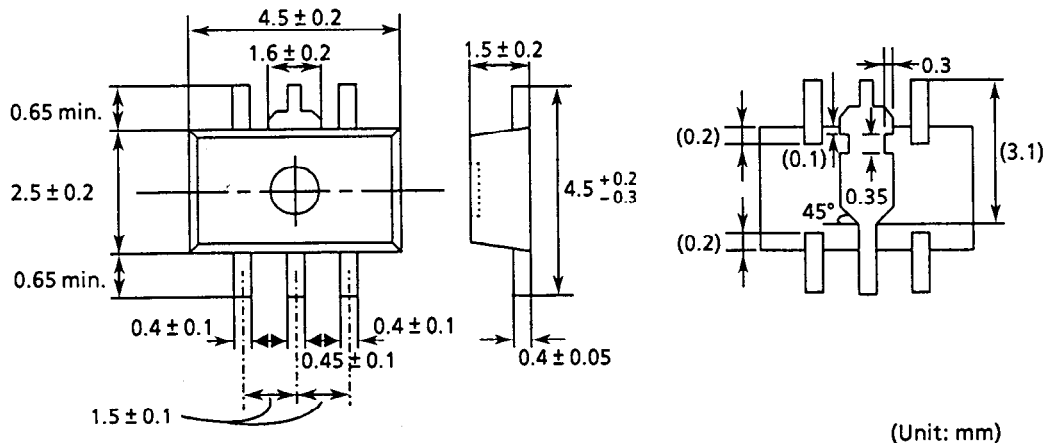

Figure 7

■ Markings

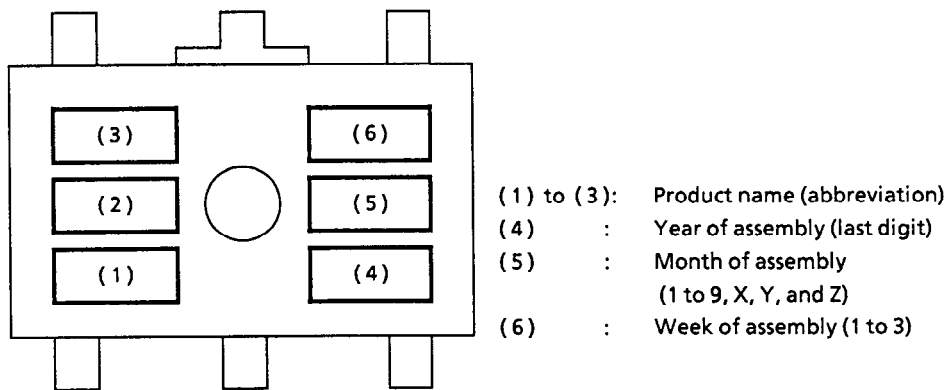

Figure 8

■ Taping

1. Tape Specifications

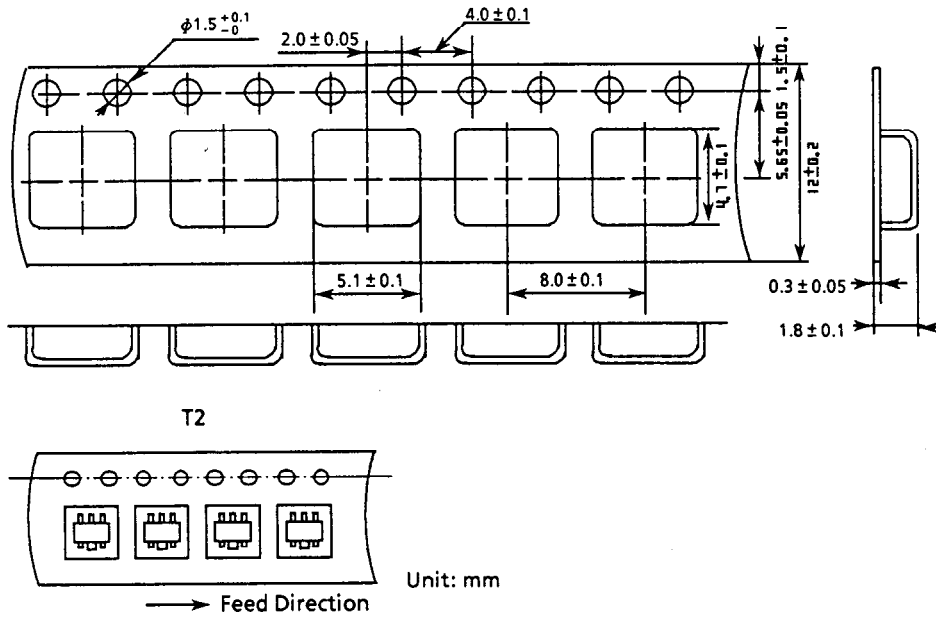

Figure 9

2. Reel Specifications

A reel holds 1000 ICs.

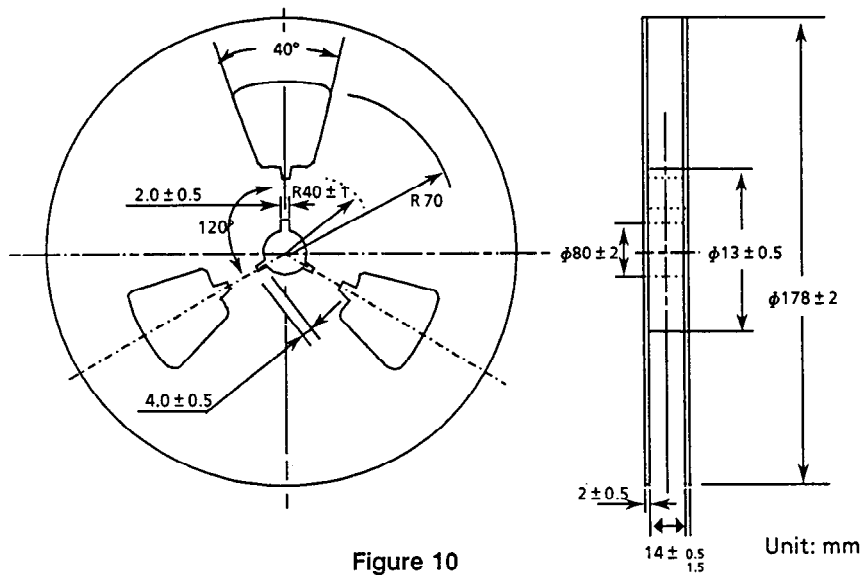
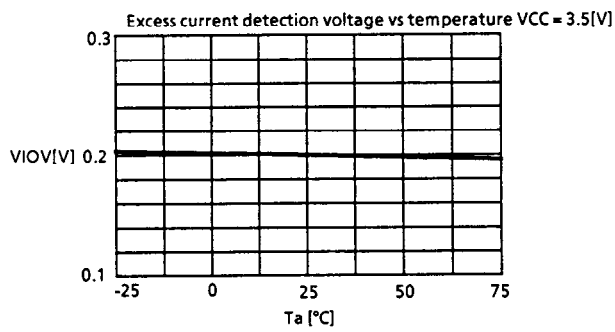
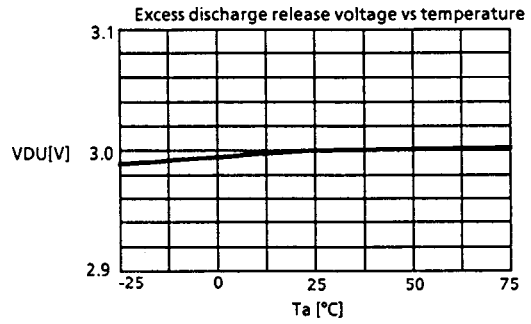
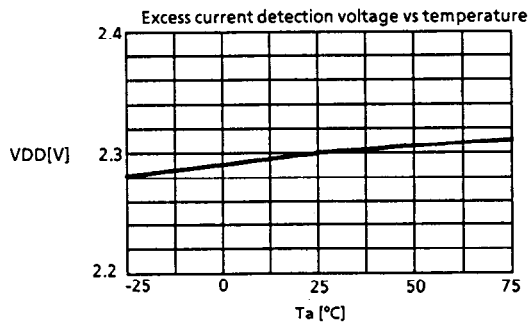
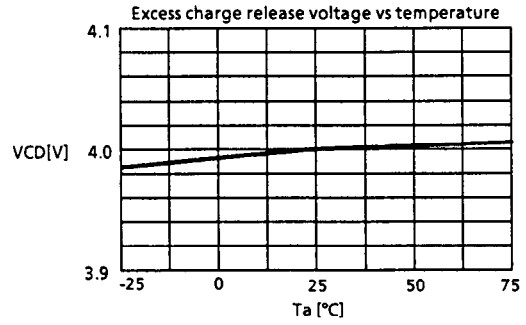
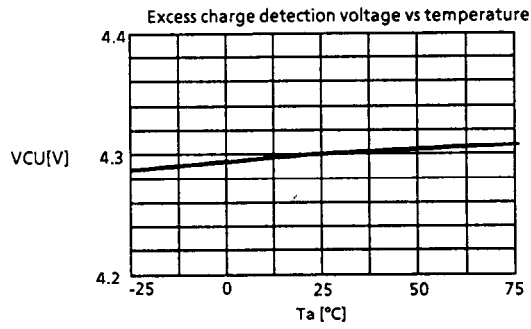

Figure 10

■ Characteristics

1. Temperature Characteristics of the Voltage Detector (Example: S8491AUP-DKA-T2)



2. Temperature characteristics of current consumption (Example: S8491AUP-DKA-T2)

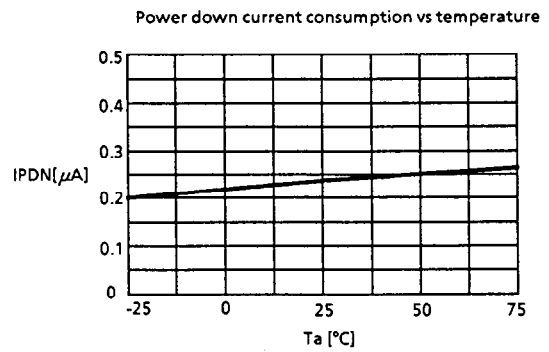
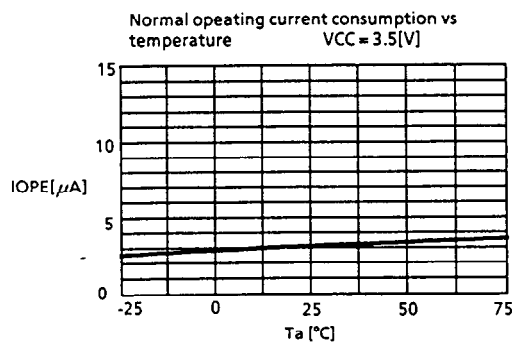

3. Temperature Characteristics of Delay Time (Example: S8491AUP-DKA-T2)

