

## INTRODUCTION

The S1T8501 is a speech network integrated circuit which includes the following components: transmit amp, receive amp, DTMF amp, voltage regulator, line equalizer, and voltage comparator. It handles the voice signal, performing the 2/4 wires interface and changing the gain on both sending and receiving amplifiers to compensate the line current. The S1T8501 can work in fixed gain mode.

## FEATURES

- Adjusts sending and receiving attenuation length
- Regulated voltage output for external dialer
- Linear interface for DTMF
- Suitable for ceramic transducers
- Mute function

## ORDERING INFORMATION

Device	Package	Operating Temperature
S1T8501X01-D0B0	16-DIP-300A	-45°C — +70°C

16-DIP-300A

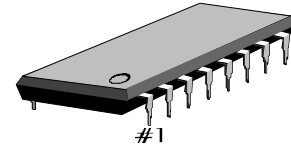

## PIN CONFIGURATION

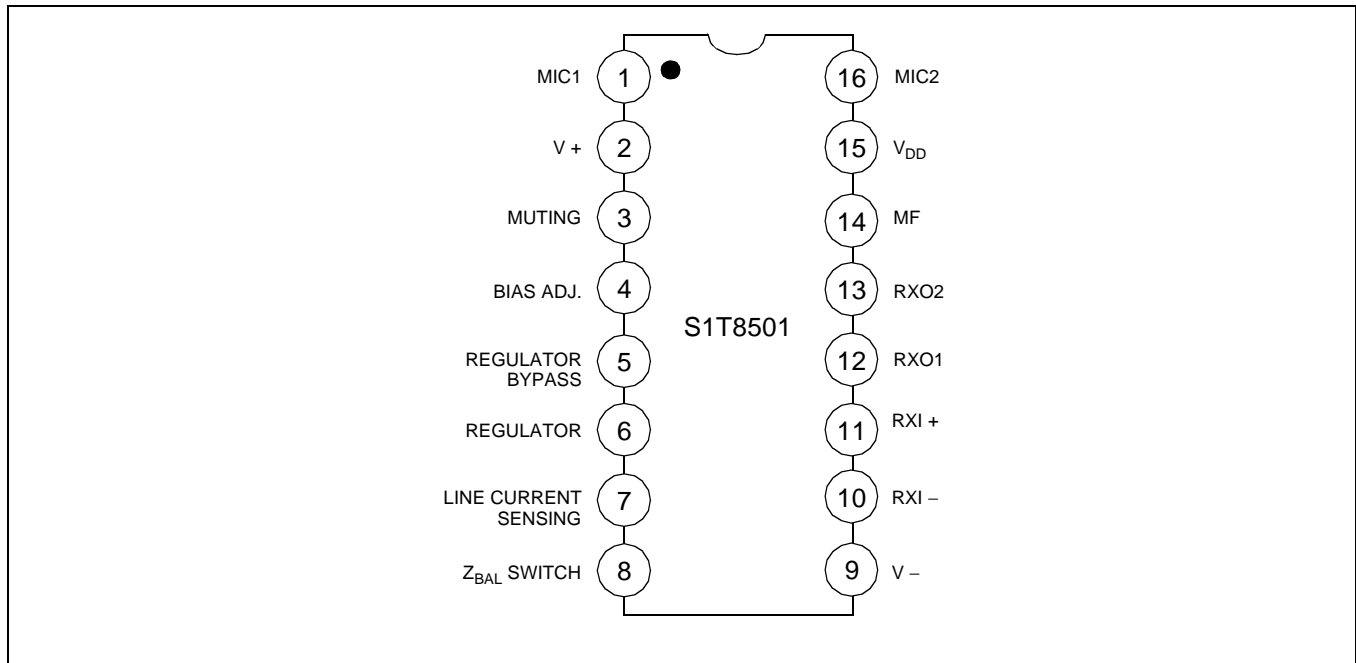

## ABSOLUTE MAXIMUM RATINGS

Characteristic	Symbol	Value	Unit
Line Voltage (3msec max)	$V_L$	22	V
Forward Line Current	$I_{LF}$	150	mA
Reverse Line Current	$I_{LR}$	-150	mA
Power Dissipation ( $T_a = 70^\circ\text{C}$ )	$P_D$	1	W
Operating Temperature	$T_{OPR}$	- 45 — + 70	$^\circ\text{C}$
Storage Temperature	$T_{STG}$	- 65 — + 150	$^\circ\text{C}$

## ELECTRICAL CHARACTERISTICS (TA = 25°C)

Characteristic	Symbol	Test Conditions		Min.	Typ.	Max.	Unit	
Line Voltage	V <sub>L</sub>	Ta = 25°C	I <sub>L</sub> = 12mA	3.9	–	4.7	V	
			I <sub>L</sub> = 20mA	–	–	5.5		
			I <sub>L</sub> = 80mA	–	–	12.2		
Common Mode Rejection Ratio	CMRR	f = 1kHz, I <sub>L</sub> = 12 to 80mA		50	–	–	dB	
Line Matching Impedance	Z <sub>L</sub>	V <sub>RI</sub> = 0.3V, I <sub>L</sub> = 12 to 80mA f = 1kHz		500	600	700	Ω	
TX Gain	G <sub>V(TX)</sub>	Ta = 25°C f = 1kHz V <sub>MI</sub> = 2mV	I <sub>L</sub> = 25mA	48	49	50	dB	
			I <sub>L</sub> = 52mA	44	45	46		
			I <sub>L</sub> = 25 to 52mA	48	49	50		
TX Gain Flatness	ΔG <sub>V(TX)</sub>	V <sub>MI</sub> = 2mV, f <sub>ref</sub> = 1kHz, I <sub>L</sub> = 12 to 80mA		–	–	± 1	dB	
TX Distortion	THD <sub>TX</sub>	f = 1kHz I <sub>L</sub> = 16 to 80mA	V <sub>SO</sub> = 1V	–	–	2	%	
			V <sub>SO</sub> = 1.3V	–	–	10		
TX Noise	V <sub>NO(TX)</sub>	V <sub>MI</sub> = 0V, I <sub>L</sub> = 40mA		–	–	–70	dBm	
Side Tone	G <sub>V(ST)</sub>	Ta = 25°C, f = 1kHz, I <sub>L</sub> = 25 to 52mA		–	–	36	dB	
MIC Input Impedance	Z <sub>I(MIC)</sub>	V <sub>MI</sub> = 2mV, I <sub>L</sub> = 12 to 80mA		40	–	–	kΩ	
Tx Loss in MF Operation	G <sub>V(LOSS)</sub>	V <sub>MI</sub> = 2mV	I <sub>L</sub> = 25mA	–30	–	–	dB	
			I <sub>L</sub> = 52mA	–30	–	–		
RX Gain	G <sub>V(RX)</sub>	Ta = 25°C V <sub>RI</sub> = 0.3V f = 1kHz	I <sub>L</sub> = 25mA	7	8	9	dB	
			I <sub>L</sub> = 52mA	2.5	3.5	4.5		
			I <sub>L</sub> = 25 to 52mA	7	8	9		
RX Gain Flatness	ΔG <sub>V(RX)</sub>	V <sub>RI</sub> = 0.3V, f <sub>ref</sub> = 1kHz, I <sub>L</sub> = 12 to 80mA		–	–	± 1	dB	
RX Distortion	THDRX	f = 1kHz	I <sub>L</sub> = 12mA	V <sub>RO</sub> = 1.6V	–	–	2	%
				V <sub>RO</sub> = 1.9V	–	–	10	
			I <sub>L</sub> = 50mA	V <sub>RO</sub> = 1.8V	–	–	2	
				V <sub>RO</sub> = 2.1V	–	–	10	
RX Noise	V <sub>NO(RX)</sub>	V <sub>RI</sub> = 0V, I <sub>L</sub> = 12 to 80mA		–	–	100	μV	
RX Output Impedance	R <sub>O(RX)</sub>	V <sub>RO</sub> = 50mV, I <sub>L</sub> = 40mA		–	–	100	Ω	
MF Supply Voltage	V <sub>DD(MF)</sub>	I <sub>L</sub> = 12 to 80mA		2.4	2.5	–	V	
MF Supply Current	Standby	I <sub>SB(MF)</sub>	I <sub>L</sub> = 12 to 80mA	0.5	–	–	mA	
	Operation	I <sub>DD(MF)</sub>		2	–	–		
MF Amplifier Gain	G <sub>V(MF)</sub>	I <sub>L</sub> = 12 to 80mA f <sub>MF</sub> = 1kHz, V <sub>MF</sub> = 80mV		15	–	17	dB	
DC Input Voltage Level (pin 14)	V <sub>I(MF)</sub>	V <sub>MF</sub> = 80mV		–	0.3V <sub>DD</sub>	–	V	
Input Impedance (pin 14)	Z <sub>I(MF)</sub>	V <sub>MF</sub> = 80mV		40	–	–	kΩ	
Distortion	THD <sub>MF</sub>	V <sub>MF</sub> = 110mV, I <sub>L</sub> = 12 to 80mA		–	–	2	%	

**ELECTRICAL CHARACTERISTICS (TA = 25°C) (Continued)**

Characteristic		Symbol	Test Conditions	Min.	Typ.	Max.	Unit
Starting Delay Time		$t_{D(ST)}$	$I_L = 12$ to $80\text{mA}$	–	–	5	mS
Muting Threshold Voltage (pin 3)		$V_{TH(MUTE)}$		–	–	1	V
				1.6	–	–	
Muting Current	Standby	$I_{SB(MUTE)}$	$I_L = 12$ to $80\text{mA}$	–	–	– 10	$\mu\text{A}$
	Operation	$I_{DD(MUTE)}$	$I_L = 12$ to $80\text{mA}$	–	–	+ 10	

APPLICATION CIRCUIT

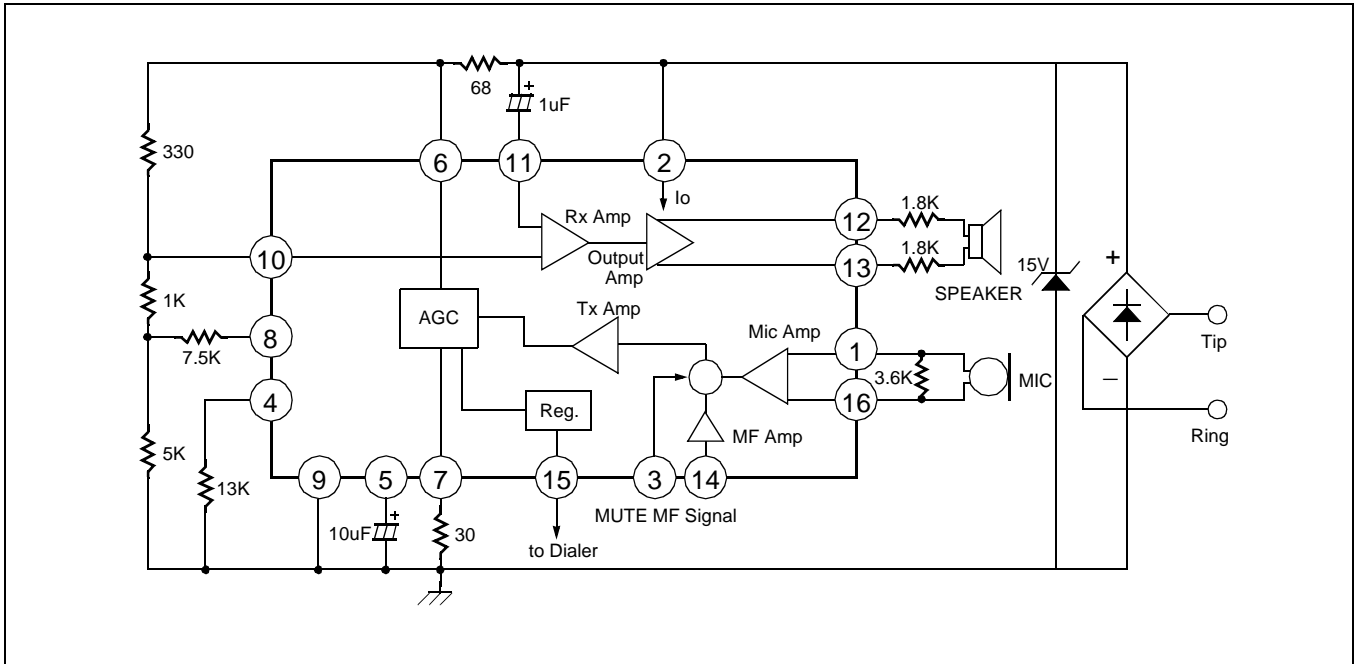

NOTES