

# S29WSI28J/064J

128/64 Megabit (8/4 M x 16-Bit)  
CMOS 1.8 Volt-only Simultaneous Read/Write,  
Burst Mode Flash Memory



## Data Sheet

## Distinctive Characteristics

### Architectural Advantages

- **Single 1.8 volt read, program and erase (1.65 to 1.95 volt)**
- **Manufactured on 0.11  $\mu$ m process technology**
- **Simultaneous Read/Write operation**
  - Data can be continuously read from one bank while executing erase/program functions in other bank
  - Zero latency between read and write operations
  - Four bank architecture: WS128J: 16Mb/48Mb/48Mb/16Mb, WS064J: 8Mb/24Mb/24Mb/8Mb
- **Programmable Burst Interface**
  - 2 Modes of Burst Read Operation
  - Linear Burst: 8, 16, and 32 words with wrap-around
  - Continuous Sequential Burst
- **Secured Silicon Sector region**
  - 128 words accessible through a command sequence, 64words for the Factory Secured Silicon Sector and 64words for the Customer Secured Silicon Sector.
- **Sector Architecture**

4 Kword x 16 boot sectors, eight at the top of the address range, and eight at the bottom of the address range

  - **WS128J:** 4 Kword X 16, 32 Kword x 254 sectors  
Bank A : 4 Kword x 8, 32 Kword x 31 sectors  
Bank B : 32 Kword x 96 sectors  
Bank C : 32 Kword x 96 sectors  
Bank D : 4 Kword x 8, 32 Kword x 31 sectors
  - **WS064J:** 4 Kword x 16, 32 Kword x 126 sectors.  
Bank A : 4 Kword x 8, 32 Kword x 15 sectors  
Bank B : 32 Kword x 48 sectors  
Bank C : 32 Kword x 48 sectors  
Bank D : 4 Kword x 8, 32 Kword x 15 sectors
- **WS128J : 84-ball (8 mm x 11.6 mm) FBGA package, WS064J : 80-ball (7 mm x 9 mm) FBGA package**
- **Cyccling Endurance : 1,000,000 cycles per sector typical**
- **Data retention : 20-years typical**

### Performance Characteristics

- **Read access times at 80/66 MHz**
  - Synchronous latency of 71/56 ns (at 30 pF)
  - Asynchronous random access times of 55/55 ns (at 30 pF)
- **Power dissipation (typical values,  $C_L = 30$  pF)**
  - Burst Mode Read: 18 mA @ 80Mhz
  - Simultaneous Operation: 60 mA @ 80Mhz
  - Program/Erase: 15 mA
  - Standby mode: 0.2  $\mu$ A

### Hardware Features

- **Handshaking feature available**
  - Provides host system with minimum possible latency by monitoring RDY
- **Hardware reset input (RESET#)**
  - Hardware method to reset the device for reading array data
- **WP# input**
  - Write protect (WP#) function allows protection of four outermost boot sectors, regardless of sector protect status
- **Persistent Sector Protection**
  - A command sector protection method to lock combinations of individual sectors and sector groups to prevent program or erase operations within that sector
  - Sectors can be locked and unlocked in-system at  $V_{CC}$  level
- **Password Sector Protection**
  - A sophisticated sector protection method to lock combinations of individual sectors and sector groups to prevent program or erase operations within that sector using a user-defined 64-bit password
- **ACC input: Acceleration function reduces programming time; all sectors locked when ACC =  $V_{IL}$**
- **CMOS compatible inputs, CMOS compatible outputs**
- **Low  $V_{CC}$  write inhibit**

### Software Features

- **Supports Common Flash Memory Interface (CFI)**
- **Software command set compatible with JEDEC 42.4 standards**
  - Backwards compatible with Am29BDS, Am29BDD, Am29BL, and MBM29BS families
- **Data# Polling and toggle bits**
  - Provides a software method of detecting program and erase operation completion
- **Erase Suspend/Resume**
  - Suspends an erase operation to read data from, or program data to, a sector that is not being erased, then resumes the erase operation
- **Unlock Bypass Program command**
  - Reduces overall programming time when issuing multiple program command sequences

## General Description

The S29WS128J/064J/S29WS064J is a 128/64 Mbit, 1.8 Volt-only, simultaneous Read/Write, Burst Mode Flash memory device, organized as 8,388,608/4,194,304 words of 16 bits each. This device uses a single  $V_{CC}$  of 1.65 to 1.95 V to read, program, and erase the memory array. A 12.0-volt  $V_{HH}$  on ACC may be used for faster program performance if desired. The device can also be programmed in standard EPROM programmers.

At 80 MHz, the device provides a burst access of 9.1 ns at 30 pF with a latency of 46 ns at 30 pF. At 66 MHz, the device provides a burst access of 11.2 ns at 30 pF with a latency of 56 ns at 30 pF. The device operates within the wireless temperature range of -25°C to +85°C, and is offered in Various FBGA packages.

The Simultaneous Read/Write architecture provides **simultaneous operation** by dividing the memory space into four banks. The device can improve overall system performance by allowing a host system to program or erase in one bank, then immediately and simultaneously read from another bank, with zero latency. This releases the system from waiting for the completion of program or erase operations.

The device is divided as shown in the following table:

Bank	Quantity		Size
	128Mb	64 Mb	
A	8	8	4 Kwords
	31	15	32 Kwords
B	96	48	32 Kwords
C	96	48	32 Kwords
D	31	15	32 Kwords
	8	8	4 Kwords

The device uses Chip Enable (CE#), Write Enable (WE#), Address Valid (AVD#) and Output Enable (OE#) to control asynchronous read and write operations. For burst operations, the device additionally requires Ready (RDY), and Clock (CLK). This implementation allows easy interface with minimal glue logic to a wide range of microprocessors/microcontrollers for high performance read operations.

The burst read mode feature gives system designers flexibility in the interface to the device. The user can preset the burst length and wrap through the same memory space, or read the flash array in continuous mode.

The clock polarity feature provides system designers a choice of active clock edges, either rising or falling. The active clock edge initiates burst accesses and determines when data will be output.

The device is entirely command set compatible with the **JEDEC 42.4 single-power-supply Flash standard**. Commands are written to the command register using standard microprocessor write timing. Register contents serve as inputs to an internal state-machine that controls the erase and programming circuitry. Write cycles also internally latch addresses and data needed for the programming and erase operations. Reading data out of the device is similar to reading from other Flash or EPROM devices.

The **Erase Suspend/Erase Resume** feature enables the user to put erase or program on hold for any period of time to read data from, or program data to, any sector that is not selected for erasure. True background erase can thus be achieved. If a read is needed from the Secured Silicon Sector area (One Time Program area) after an erase suspend, then the user must use the proper command sequence to enter and exit this region. Program suspend is also offered.

The **hardware RESET# pin** terminates any operation in progress and resets the internal state machine to reading array data. The RESET# pin may be tied to the system reset circuitry. A system reset would thus also reset the device, enabling the system microprocessor to read boot-up firmware from the Flash memory device.

The host system can detect whether a program or erase operation is complete by using the device status bit DQ7 (Data# Polling) and DQ6/DQ2 (toggle bits). After a program or erase cycle has been completed, the device automatically returns to reading array data.

The **sector erase architecture** allows memory sectors to be erased and reprogrammed without affecting the data contents of other sectors. The device is fully erased when shipped from the factory.

**Hardware data protection** measures include a low  $V_{CC}$  detector that automatically inhibits write operations during power transitions. The device also offers two types of data protection at the sector level. When at  $V_{IL}$ , **WP#** locks the four outermost boot sectors.

The device offers two power-saving features. When addresses have been stable for a specified amount of time, the device enters the **automatic sleep mode**. The system can also place the device into the **standby mode**. Power consumption is greatly reduced in both modes.

Spansion™ Flash memory products combine years of Flash memory manufacturing experience to produce the highest levels of quality, reliability and cost effectiveness. The device electrically erases all bits within a sector simultaneously via Fowler-Nordheim tunnelling. The data is programmed using hot electron injection.

## Table of Contents

<b>Notice On Data Sheet Designations</b> . . . . .	<b>ii</b>	<b>Command Definitions</b> . . . . .	<b>46</b>
Advance Information . . . . .	ii	Reading Array Data . . . . .	46
Preliminary . . . . .	ii	Set Configuration Register Command Sequence . . . . .	47
Combination . . . . .	ii	Figure 4. Synchronous/Asynchronous State Diagram . . . . .	48
Full Production (No Designation on Document) . . . . .	ii	Read Mode Setting . . . . .	48
<b>Product Selector Guide</b> . . . . .	<b>6</b>	Programmable Wait State Configuration . . . . .	48
<b>Block Diagram</b> . . . . .	<b>6</b>	Table 14. Programmable Wait State Settings . . . . .	49
<b>Block Diagram of Simultaneous Operation Circuit 7</b>	<b>7</b>	Standard wait-state Handshaking Option . . . . .	49
<b>Connection Diagram</b> . . . . .	<b>8</b>	Table 15. Wait States for Standard wait-state Handshaking . . . . .	49
Special Handling Instructions for FBGA Package . . . . .	8	Read Mode Configuration . . . . .	50
<b>Connection Diagram</b> . . . . .	<b>9</b>	Table 16. Read Mode Settings . . . . .	50
<b>Input/Output Descriptions</b> . . . . .	<b>10</b>	Burst Active Clock Edge Configuration . . . . .	50
<b>Logic Symbol</b> . . . . .	<b>11</b>	RDY Configuration . . . . .	50
<b>Ordering Information</b> . . . . .	<b>12</b>	Configuration Register . . . . .	50
128 Mb Products based on 110 nm Floating Gate Technology . . . . .	13	Table 17. Configuration Register . . . . .	51
64 Mb Products based on 110 nm Floating Gate Technology . . . . .	13	Reset Command . . . . .	51
<b>Device Bus Operations</b> . . . . .	<b>14</b>	Autoselect Command Sequence . . . . .	51
Table 1. Device Bus Operations . . . . .	14	Enter Secured Silicon Sector/Exit Secured Silicon Sector Command Sequence . . . . .	52
Requirements for Asynchronous Read Operation (Non-Burst) . . . . .	14	Program Command Sequence . . . . .	53
Requirements for Synchronous (Burst) Read Operation . . . . .	14	Unlock Bypass Command Sequence . . . . .	53
8-, 16-, and 32-Word Linear Burst with Wrap Around . . . . .	15	Figure 5. Program Operation . . . . .	54
Table 2. Burst Address Groups . . . . .	15	Chip Erase Command Sequence . . . . .	54
Configuration Register . . . . .	16	Sector Erase Command Sequence . . . . .	55
Handshaking . . . . .	16	Erase Suspend/Erase Resume Commands . . . . .	55
Simultaneous Read/Write Operations with Zero Latency . . . . .	16	Figure 6. Erase Operation . . . . .	56
Writing Commands/Command Sequences . . . . .	16	Password Program Command . . . . .	57
Accelerated Program Operation . . . . .	17	Password Verify Command . . . . .	57
Autoselect Mode . . . . .	17	Password Protection Mode Locking Bit Program Command . . . . .	57
Table 3. Autoselect Codes (High Voltage Method) . . . . .	18	Persistent Sector Protection Mode Locking Bit Program Command . . . . .	57
Sector/Sector Block Protection and Unprotection . . . . .	18	Secured Silicon Sector Protection Bit Program Command . . . . .	58
Table 4. S29WS128J/064J Boot Sector/Sector Block Addresses for Protection/Unprotection . . . . .	18	PPB Lock Bit Set Command . . . . .	58
Table 5. S29WS064J Boot Sector/Sector Block Addresses for Protection/Unprotection . . . . .	21	DPB Write/Erase/Status Command . . . . .	58
<b>Advanced Sector Protection/Unprotection</b> . . . . .	<b>23</b>	Password Unlock Command . . . . .	58
Figure 1. Advanced Sector Protection/Unprotection . . . . .	23	PPB Program Command . . . . .	59
Lock Register . . . . .	24	All PPB Erase Command . . . . .	59
Table 6. Lock Register . . . . .	24	PPB Status Command . . . . .	59
Persistent Protection Bits . . . . .	24	PPB Lock Bit Status Command . . . . .	59
Figure 2. PPB Program/Erase Algorithm . . . . .	26	Command Definitions . . . . .	60
Dynamic Protection Bits . . . . .	26	Table 18. Command Definitions . . . . .	60
Persistent Protection Bit Lock Bit . . . . .	27	<b>Write Operation Status</b> . . . . .	<b>62</b>
Password Protection Method . . . . .	27	DQ7: Data# Polling . . . . .	62
Figure 3. Lock Register Program Algorithm . . . . .	28	Figure 7. Data# Polling Algorithm . . . . .	63
Advanced Sector Protection Software Examples . . . . .	29	RDY: Ready . . . . .	63
Table 7. Sector Protection Schemes . . . . .	29	DQ6: Toggle Bit I . . . . .	64
Hardware Data Protection Methods . . . . .	29	Figure 8. Toggle Bit Algorithm . . . . .	65
WP# Method . . . . .	29	DQ2: Toggle Bit II . . . . .	65
ACC Method . . . . .	29	Table 19. DQ6 and DQ2 Indications . . . . .	66
Low V <sub>CC</sub> Write Inhibit . . . . .	29	Reading Toggle Bits DQ6/DQ2 . . . . .	66
Write Pulse “Glitch Protection” . . . . .	30	DQ5: Exceeded Timing Limits . . . . .	66
Power-Up Write Inhibit . . . . .	30	DQ3: Sector Erase Timer . . . . .	67
<b>Common Flash Memory Interface (CFI)</b> . . . . .	<b>30</b>	Table 20. Write Operation Status . . . . .	67
Table 8. CFI Query Identification String . . . . .	30	<b>Absolute Maximum Ratings</b> . . . . .	<b>68</b>
Table 9. System Interface String . . . . .	31	Figure 9. Maximum Negative Overshoot Waveform . . . . .	68
Table 10. Device Geometry Definition . . . . .	31	Figure 10. Maximum Positive Overshoot Waveform . . . . .	68
Table 11. Primary Vendor-Specific Extended Query . . . . .	32	<b>Operating Ranges</b> . . . . .	<b>69</b>
Table 12. WS128J Sector Address Table . . . . .	33	Commercial (C) Devices . . . . .	69
Table 13. WS064J Sector Address Table . . . . .	41	Wireless (W) Devices . . . . .	69
		Supply Voltages . . . . .	69

<b>DC Characteristics</b> .....	<b>70</b>	Figure 26. Synchronous Program Operation Timings: CLK Latched Addresses .....	84
<b>Test Conditions</b> .....	<b>71</b>	Figure 27. Chip/Sector Erase Command Sequence .....	85
Figure 11. Test Setup .....	71	Figure 28. Accelerated Unlock Bypass Programming Timing .....	86
Table 21. Test Specifications .....	71	Figure 29. Data# Polling Timings (During Embedded Algorithm) .....	86
<b>Key to Switching Waveforms</b> .....	<b>71</b>	Figure 30. Toggle Bit Timings (During Embedded Algorithm) .....	87
<b>Switching Waveforms</b> .....	<b>71</b>	Figure 31. Synchronous Data Polling Timings/Toggle Bit Timings .....	87
Figure 12. Input Waveforms and Measurement Levels.....	71	Figure 32. DQ2 vs. DQ6.....	88
<b>AC Characteristics</b> .....	<b>72</b>	Temporary Sector Unprotect .....	88
V <sub>CC</sub> Power-up .....	72	Figure 33. Temporary Sector Unprotect Timing Diagram .....	88
Figure 13. V <sub>CC</sub> Power-up Diagram .....	72	Figure 34. Sector/Sector Block Protect and Unprotect Timing Diagram .....	89
CLK Characterization .....	72	Figure 35. Latency with Boundary Crossing .....	89
Figure 14. CLK Characterization .....	72	Figure 36. Latency with Boundary Crossing into Program/Erase Bank .....	90
Synchronous/Burst Read .....	73	Figure 37. Example of Wait States Insertion .....	91
Figure 15. CLK Synchronous Burst Mode Read (rising active CLK). .....	74	Figure 38. Back-to-Back Read/Write Cycle Timings.....	92
Figure 16. CLK Synchronous Burst Mode Read (Falling Active Clock) .....	75	<b>Erase and Programming Performance</b> .....	<b>93</b>
Figure 17. Synchronous Burst Mode Read.....	75	<b>Physical Dimensions</b> .....	<b>94</b>
Figure 18. 8-word Linear Burst with Wrap Around.....	76	VBH084 - 84-ball Fine-Pitch Ball Grid Array (FBGA) 8x11.6 mm MCP Compatible Package (128Mb) .....	94
Figure 19. Linear Burst with RDY Set One Cycle Before Data .....	76	VBR080 - 80-ball Fine-Pitch Ball Grid Array (FBGA) 7 x 9 mm (64Mb) .....	95
Asynchronous Mode Read .....	77	<b>Revision Summary</b> .....	<b>96</b>
Figure 20. Asynchronous Mode Read with Latched Addresses ...	77	Revision A0 (July 22, 2004) .....	96
Figure 21. Asynchronous Mode Read.....	78	Revision A1 (October 6, 2004) .....	96
Hardware Reset (RESET#) .....	78	Revision A2 (December 10, 2004) .....	96
Figure 22. Reset Timings.....	79	Revision A3 (February 19, 2005) .....	96
Erase/Program Operations .....	80	Revision A4 (June 24, 2005) .....	96
Figure 23. Asynchronous Program Operation Timings: AVD# Latched Addresses .....	81	Revision A5 (March 31, 2006) .....	96
Figure 24. Asynchronous Program Operation Timings: WE# Latched Addresses .....	82	Revision A6 (April 28, 2006) .....	97
Figure 25. Synchronous Program Operation Timings: WE# Latched Addresses .....	83		

## Product Selector Guide

Synchronous/Burst			Asynchronous		
Speed Option	66 MHz	80 MHz (Note)	Speed Option	66 MHz	80 MHz (Note)
Max Latency, ns ( $t_{IACC}$ )	56	71	Max Access Time, ns ( $t_{ACC}$ )	55	55
Max Burst Access Time, ns ( $t_{BACC}$ )	11.2	9.1	Max CE# Access, ns ( $t_{CE}$ )	55	55
Max OE# Access, ns ( $t_{OE}$ )	11.2	9.1	Max OE# Access, ns ( $t_{OE}$ )	11.2	9.1

**Note:** 80 MHz option is available for S29WS064J only.

## Block Diagram

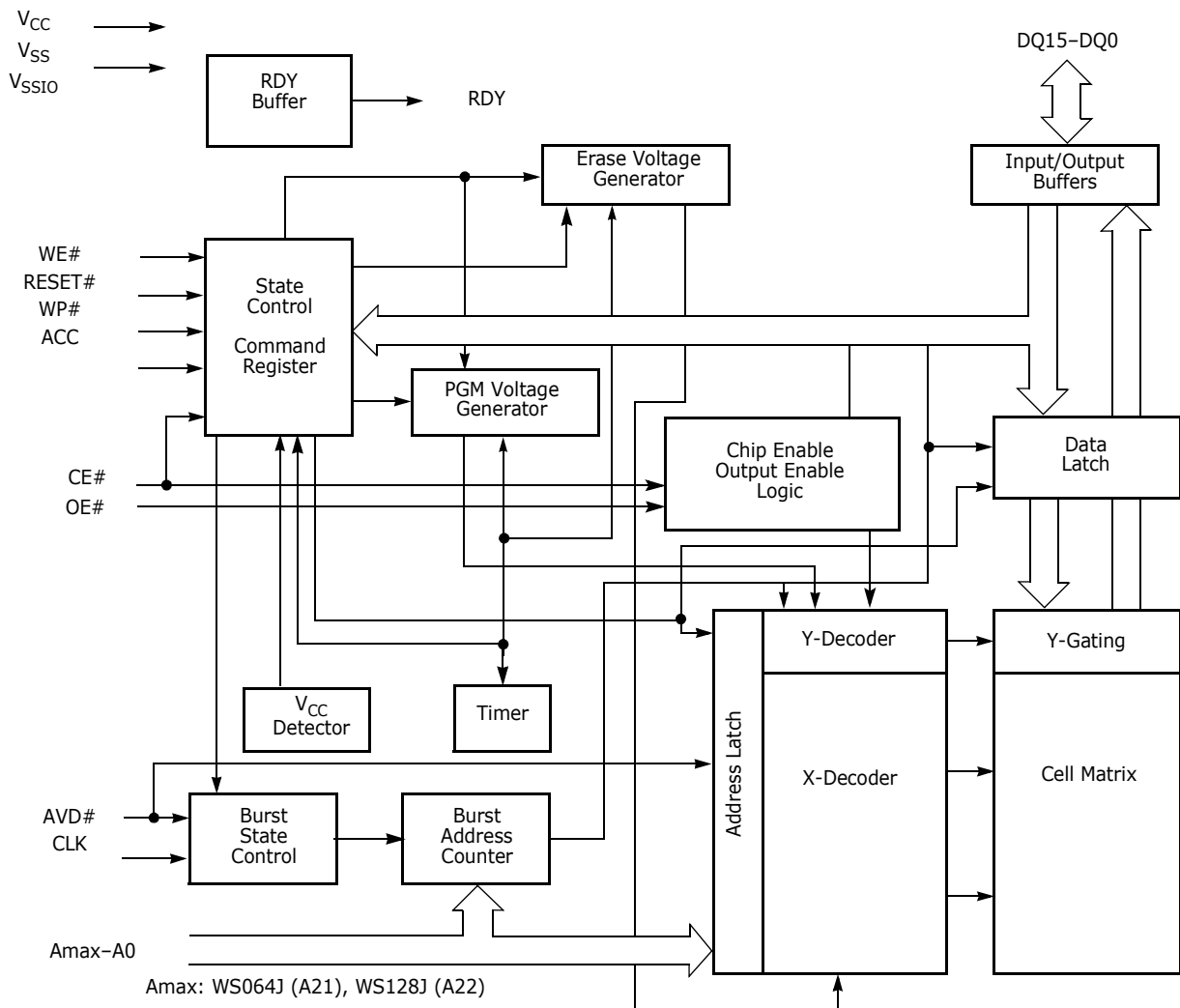

### Block Diagram of Simultaneous Operation Circuit

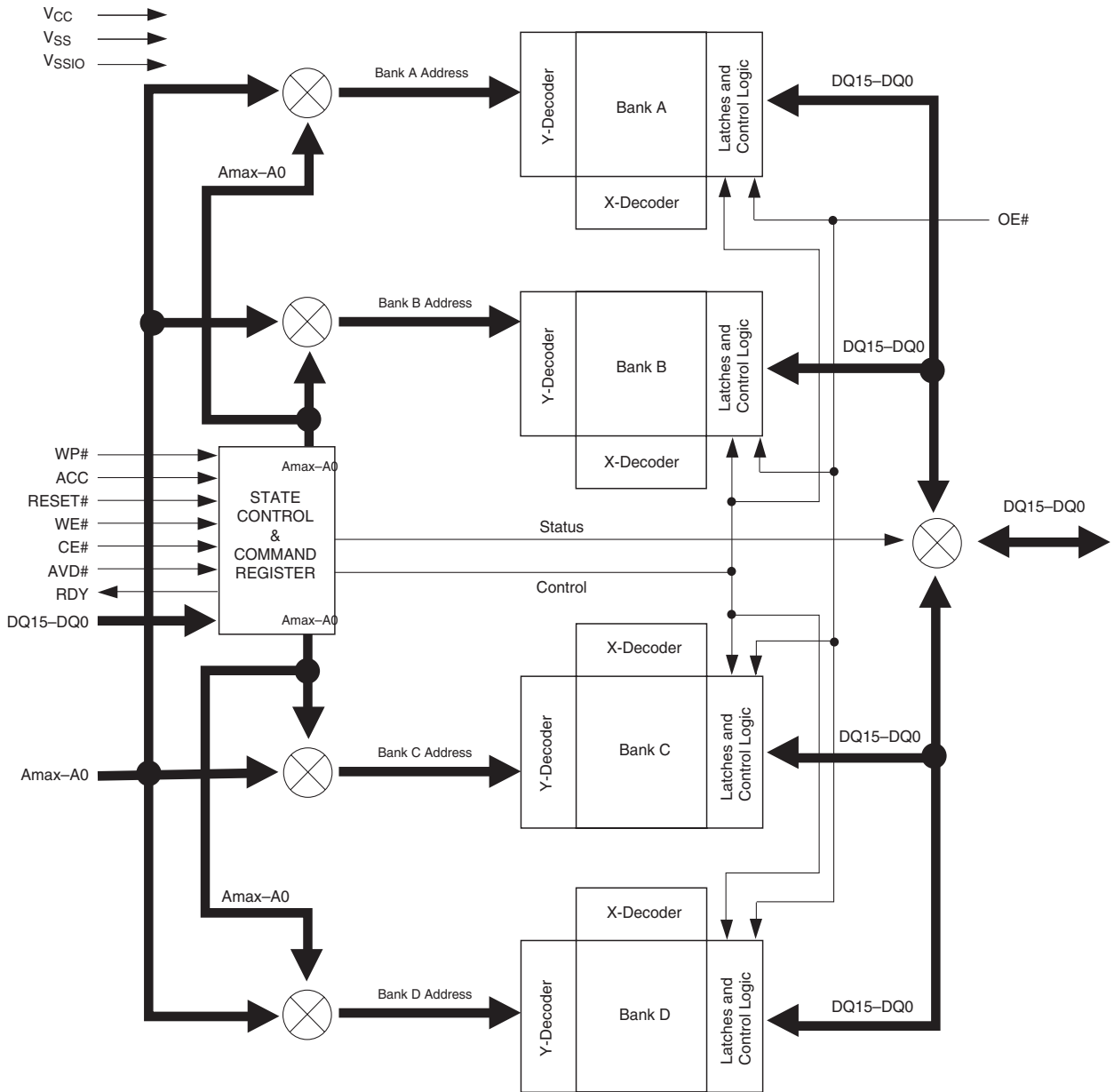

**Note:** Amax: WS064J (A21), WS128J (A22)

## Connection Diagram

### S29WS064J 80-ball Fine-Pitch Ball Grid Array (Top View, Balls Facing Down)

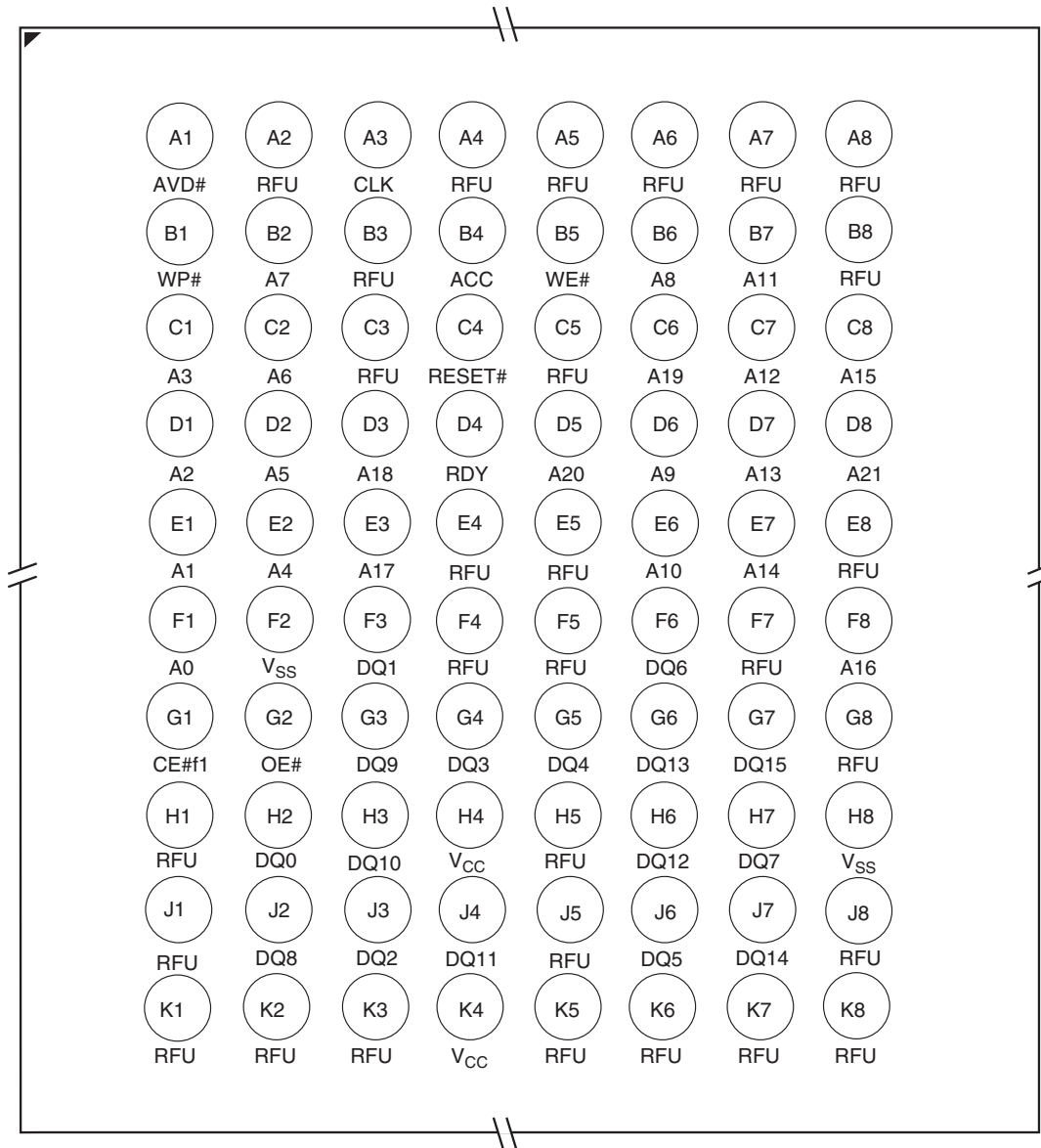

### Special Handling Instructions for FBGA Package

Special handling is required for Flash Memory products in FBGA packages.

Flash memory devices in FBGA packages may be damaged if exposed to ultrasonic cleaning methods. The package and/or data integrity may be compromised if the package body is exposed to temperatures above 150°C for prolonged periods of time.



## Connection Diagram

### S29WS128J-MCP Compatible 84-ball Fine-Pitch Ball Grid Array (Top View, Balls Facing Down)

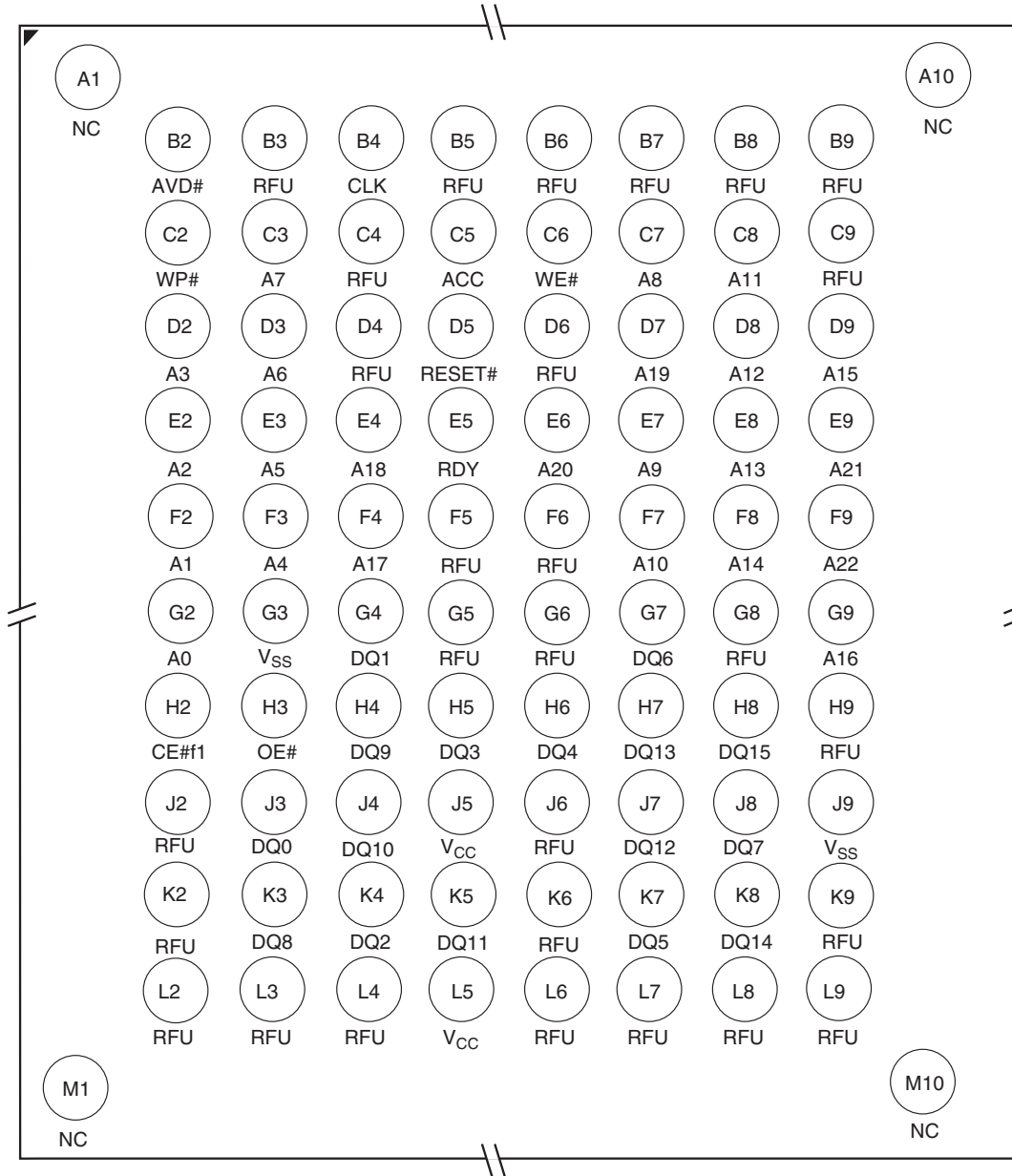

## Input/Output Descriptions

Amax-A0	=	Address inputs
DQ15-DQ0	=	Data input/output
CE#	=	Chip Enable input. Asynchronous relative to CLK for the Burst mode.
OE#	=	Output Enable input. Asynchronous relative to CLK for the Burst mode.
WE#	=	Write Enable input.
V <sub>CC</sub>	=	Device Power Supply (1.65 – 1.95 V).
V <sub>SS</sub>	=	Ground
NC	=	No Connect; not connected internally
RDY	=	Ready output; In Synchronous Mode, indicates the status of the Burst read. Low = data not valid at expected time. High = data valid. In Asynchronous Mode, indicates the status of the internal program and erase function. Low = program/erase in progress. High Impedance = program/erase completed.
CLK	=	CLK is not required in asynchronous mode. In burst mode, after the initial word is output, subsequent active edges of CLK increment the internal address counter.
AVD#	=	Address Valid input. Indicates to device that the valid address is present on the address inputs (Amax-A0). Low = for asynchronous mode, indicates valid address; for burst mode, causes starting address to be latched. High = device ignores address inputs
RESET#	=	Hardware reset input. Low = device resets and returns to reading array data
WP#	=	Hardware write protect input. At V <sub>IL</sub> , disables program and erase functions in the four outermost sectors. Should be at V <sub>IH</sub> for all other conditions.
ACC	=	At V <sub>HH</sub> , accelerates programming; automatically places device in unlock bypass mode. At V <sub>IL</sub> , locks all sectors. Should be at V <sub>IH</sub> for all other conditions.

**Note:**

1. Amax = A22 (WS128J), A21 (WS064J).

## Logic Symbol

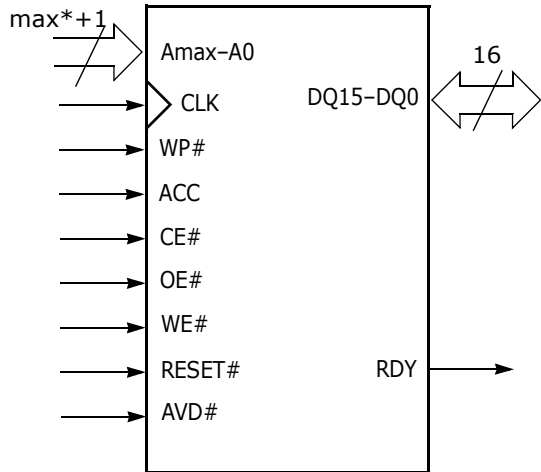

\*Max = 22 for the WS128J and 21 for the WS064J.

## Ordering Information

The order number (Valid Combination) is formed by the following:

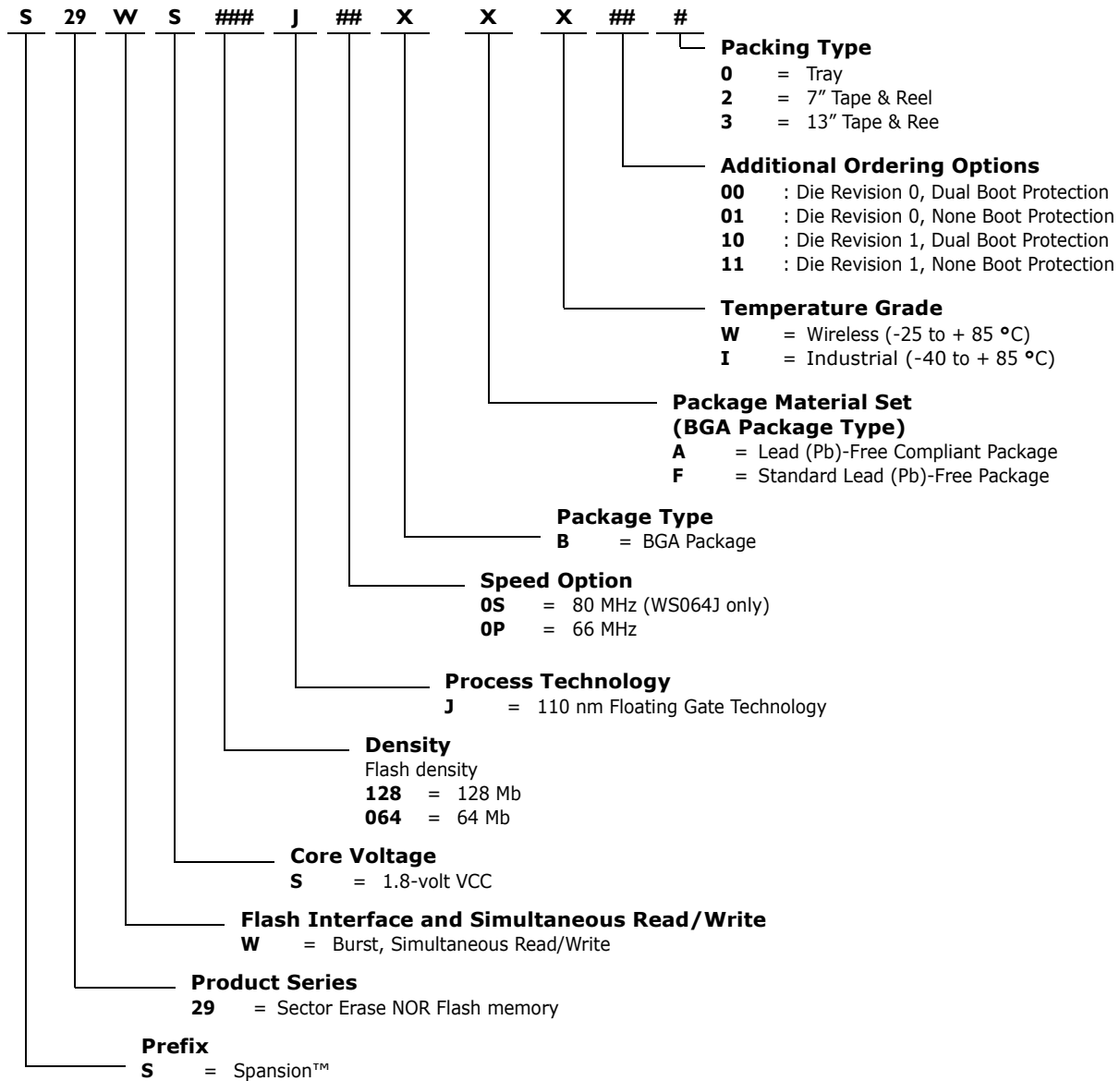

### 128 Mb Products based on 110 nm Floating Gate Technology

Valid Combinations for FBGA Packages	Package Marking	Temperature	Burst Speed	Boot Protect	Package Material Set	Package Type	
S29WS128J0PBAW00	WS128J0PBAW00	(-25 - +85 °C)	66 MHz	Dual	Lead (Pb)-Free Compliant Package	84 - ball 8mm x 11.6mm MCP Compatible	
S29WS128J0PBAW01	WS128J0PBAW01			None			
S29WS128J0PBAW10	WS128J0PBAW10			Dual			
S29WS128J0PBAW11	WS128J0PBAW11			None			
S29WS128J0PBAI10	WS128J0PBAI10	(-40 - +85 °C)		Dual			
S29WS128J0PBAI11	WS128J0PBAI11			None			
S29WS128J0PBFW00	WS128J0PBFW00	(-25 - +85 °C)		Dual	Standard Lead (Pb)-Free Package		
S29WS128J0PBFW01	WS128J0PBFW01			None			
S29WS128J0PBFW10	WS128J0PBFW10			Dual			
S29WS128J0PBFW11	WS128J0PBFW11			None			
S29WS128J0PBFI10	WS128J0PBFI10			(-40 - +85 °C)			Dual
S29WS128J0PBFI11	WS128J0PBFI11						None

### 64 Mb Products based on 110 nm Floating Gate Technology

Valid Combinations for FBGA Packages	Package Marking	Temperature	Burst Speed	Boot Protect	Package Material Set	Package Type
S29WS064J0PBAW00	WS064J0PBAW00	(-25 - +85 °C)	66 MHz	Dual	Lead (Pb)-Free Compliant Package	80 - ball 7mm x 9mm MCP Compatible
S29WS064J0SBAW00	WS064J0SBAW00	(-25 - +85 °C)	80 MHz			
S29WS064J0PBAW01	WS064J0PBAW01	(-25 - +85 °C)	66 MHz	None		
S29WS064J0SBAW01	WS064J0SBAW01	(-25 - +85 °C)	80 MHz			
S29WS064J0PBFW00	WS064J0PBFW00	(-25 - +85 °C)	66 MHz	Dual	Standard Lead (Pb)-Free Package	
S29WS064J0SBFW00	WS064J0SBFW00	(-25 - +85 °C)	80 MHz			
S29WS064J0PBFW01	WS064J0PBFW01	(-25 - +85 °C)	66 MHz	None		
S29WS064J0SBFW01	WS064J0SBFW01	(-25 - +85 °C)	80 MHz			

#### Valid Combinations

Valid Combination configuration planned to be supported for this device.

#### Notes:

1.80 MHz operation has a different Vcc(+1.70V to 1.95V).

## Device Bus Operations

This section describes the requirements and use of the device bus operations, which are initiated through the internal command register. The command register itself does not occupy any addressable memory location. The register is composed of latches that store the commands, along with the address and data information needed to execute the command. The contents of the register serve as inputs to the internal state machine. The state machine outputs dictate the function of the device. Table 1 lists the device bus operations, the inputs and control levels they require, and the resulting output. The following subsections describe each of these operations in further detail.

**Table 1. Device Bus Operations**

Operation	CE#	OE#	WE#	A22-0	DQ15-0	RESET#	CLK (See Note)	AVD#
Asynchronous Read - Addresses Latched	L	L	H	Addr In	I/O	H	X	
Asynchronous Read - Addresses Steady State	L	L	H	Addr In	I/O	H	X	L
Asynchronous Write	L	H	L	Addr In	I/O	H	X	L
Synchronous Write	L	H	L	Addr In	I/O	H		
Standby (CE#)	H	X	X	HIGH Z	HIGH Z	H	X	X
Hardware Reset	X	X	X	HIGH Z	HIGH Z	L	X	X
<b>Burst Read Operations</b>								
Load Starting Burst Address	L	X	H	Addr In	X	H		
Advance Burst to next address with appropriate Data presented on the Data Bus	L	L	H	HIGH Z	Burst Data Out	H		H
Terminate current Burst read cycle	H	X	H	HIGH Z	HIGH Z	H		X
Terminate current Burst read cycle via RESET#	X	X	H	HIGH Z	HIGH Z	L	X	X
Terminate current Burst read cycle and start new Burst read cycle	L	X	H	HIGH Z	I/O	H		

**Legend:** L = Logic 0, H = Logic 1, X = Don't Care

**Note:** Default active edge of CLK is the rising edge.

### Requirements for Asynchronous Read Operation (Non-Burst)

To read data from the memory array, the system must first assert a valid address on Amax-A0 (A22-A0 for WS128J and A21-A0 for WS064J), while driving AVD# and CE# to  $V_{IL}$ . WE# should remain at  $V_{IH}$ . The rising edge of AVD# latches the address. The data will appear on DQ15-DQ0. Since the memory array is divided into four banks, each bank remains enabled for read access until the command register contents are altered.

Address access time ( $t_{ACC}$ ) is equal to the delay from stable addresses to valid output data. The chip enable access time ( $t_{CE}$ ) is the delay from the stable addresses and stable CE# to valid data at the outputs. The output enable access time ( $t_{OE}$ ) is the delay from the falling edge of OE# to valid data at the output.

The internal state machine is set for reading array data in asynchronous mode upon device power-up, or after a hardware reset. This ensures that no spurious alteration of the memory content occurs during the power transition.

### Requirements for Synchronous (Burst) Read Operation

The device is capable of continuous sequential burst operation and linear burst operation of a pre-set length. When the device first powers up, it is enabled for asynchronous read operation.

Prior to entering burst mode, the system should determine how many wait states are desired for the initial word ( $t_{IACC}$ ) of each burst access, what mode of burst operation is desired, which edge of the clock will be the active clock edge, and how the RDY signal will transition with valid data. The system would then write the configuration register command sequence. See "Set Configuration Register Command Sequence" section on page 47 and "Command Definitions" section on page 46 for further details.

Once the system has written the "Set Configuration Register" command sequence, the device is enabled for synchronous reads only.

The initial word is output  $t_{IACC}$  after the active edge of the first CLK cycle. Subsequent words are output  $t_{BACC}$  after the active edge of each successive clock cycle, which automatically increments the internal address counter. Note that the device has a fixed internal address boundary that occurs every 64 words, starting at address 00003Fh.

During the time the device is outputting data at this fixed internal address boundary (address 00003Fh, 00007Fh, 0000BFh, etc.), a two cycle latency (WS128J/064J model numbers 00 and 01) or a three cycle latency (WS128J model numbers 10 and 11) occurs before data appears for the next address (address 000040h, 000080h, 0000C0h, etc.).

Additionally, when the device is read from an odd address, one wait state is inserted when the address pointer crosses the first boundary that occurs every 16 words. For instance, if the device is read from 000011h, 000013h, ... ,00001Fh (odd), one wait state is inserted before the data of 000020h is output. This wait is inserted only at the boundary of the first 16 words. Then, if the device is read from the odd address within the last 16 words of 64 word boundary (address 000031h,000033h, ... , 00003Fh), a three-cycle latency occurs before data appears for the next address (address 000040h). During the boundary crossing condition, the system must assert an additional wait state for WS128J model numbers 10 and 11.

The RDY output indicates this condition to the system by pulsing deactive (low). See [Figure 35, "Latency with Boundary Crossing,"](#) on page 89.

The device will continue to output sequential burst data, wrapping around to address 000000h after it reaches the highest addressable memory location, until the system drives CE# high, RESET# low, or AVD# low in conjunction with a new address. See [Table 1, "Device Bus Operations,"](#) on page 14.

If the host system crosses the bank boundary while reading in burst mode, and the device is not programming or erasing, a two-cycle latency will occur as described above in the subsequent bank. If the host system crosses the bank boundary while the device is programming or erasing, the device will provide read status information. The clock will be ignored. After the host has completed status reads, or the device has completed the program or erase operation, the host can restart a burst operation using a new address and AVD# pulse.

### 8-, 16-, and 32-Word Linear Burst with Wrap Around

The remaining three burst read modes are of the linear wrap around design, in which a fixed number of words are read from consecutive addresses. In each of these modes, the burst addresses read are determined by the group within which the starting address falls. The groups are sized according to the number of words read in a single burst sequence for a given mode (see [Table 2.](#))

**Table 2. Burst Address Groups**

Mode	Group Size	Group Address Ranges
8-word	8 words	0-7h, 8-Fh, 10-17h,...
16-word	16 words	0-Fh, 10-1Fh, 20-2Fh,...
32-word	32 words	00-1Fh, 20-3Fh, 40-5Fh,...

As an example: if the starting address in the 8-word mode is 39h, the address range to be read would be 38-3Fh, and the burst sequence would be 39-3A-3B-3C-3D-3E-3F-38h-etc. The burst sequence begins with the starting address written to the device, but wraps back to the first address in the selected group. In a similar fashion, the 16-word and 32-word Linear Wrap modes begin their burst sequence on the starting address written to the device, and then wrap back to the first address in the selected address group. **Note that in these three burst read modes the address pointer does not cross the boundary that occurs every 128 or 64 words; thus, no wait states are inserted (except during the initial access).**

The RDY pin indicates when data is valid on the bus.

## Configuration Register

The device uses a configuration register to set the various burst parameters: number of wait states, burst read mode, active clock edge, RDY configuration, and synchronous mode active.

## Handshaking

The device is equipped with a handshaking feature that allows the host system to simply monitor the RDY signal from the device to determine when the initial word of burst data is ready to be read. The host system should use the programmable wait state configuration to set the number of wait states for optimal burst mode operation. The initial word of burst data is indicated by the active edge of RDY after OE# goes low.

For optimal burst mode performance, the host system must set the appropriate number of wait states in the flash device depending on clock frequency. See "Set Configuration Register Command Sequence" section on page 47 for more information.

## Simultaneous Read/Write Operations with Zero Latency

This device is capable of reading data from one bank of memory while programming or erasing in another bank of memory. An erase operation may also be suspended to read from or program to another location within the same bank (except the sector being erased). [Figure 38, "Back-to-Back Read/Write Cycle Timings," on page 92](#) shows how read and write cycles may be initiated for simultaneous operation with zero latency. Refer to the DC Characteristics table for read-while-program and read-while-erase current specifications.

## Writing Commands/Command Sequences

The device has the capability of performing an asynchronous or synchronous write operation. While the device is configured in Asynchronous read mode, it is able to perform Asynchronous write operations only. CLK is ignored in the Asynchronous programming mode. When in the Synchronous read mode configuration, the device is able to perform both Asynchronous and Synchronous write operations. CLK and WE# address latch is supported in the Synchronous programming mode. During a synchronous write operation, to write a command or command sequence (which includes programming data to the device and erasing sectors of memory), the system must drive AVD# and CE# to  $V_{IL}$ , and OE# to  $V_{IH}$  when providing an address to the device, and drive WE# and CE# to  $V_{IL}$ , and OE# to  $V_{IH}$  when writing commands or data. During an asynchronous write operation, the system must drive CE# and WE# to  $V_{IL}$  and OE# to  $V_{IH}$  when providing an address, command, and data. Addresses are latched on the last falling edge of WE# or CE#, while data is latched on the 1st rising edge of WE# or CE#. The asynchronous and synchronous programming operation is independent of the Set Device Read Mode bit in the Configuration Register (see [Table 17, "Configuration Register," on page 51](#)).

The device features an Unlock Bypass mode to facilitate faster programming. Once the device enters the Unlock Bypass mode, only two write cycles are required to program a word, instead of four.



An erase operation can erase one sector, multiple sectors, or the entire device. [Table 12, “WS128J Sector Address Table,” on page 33](#) and [Table 13, “WS064J Sector Address Table,” on page 41](#) indicate the address space that each sector occupies. The device address space is divided into four banks. A “bank address” is the address bits required to uniquely select a bank. Similarly, a “sector address” is the address bits required to uniquely select a sector.

$I_{CC2}$  in the “DC Characteristics” section on page 70 represents the active current specification for the write mode. The AC Characteristics section contains timing specification tables and timing diagrams for write operations.

## Accelerated Program Operation

The device offers accelerated program operations through the ACC function. ACC is primarily intended to allow faster manufacturing throughput at the factory.

If the system asserts  $V_{HH}$  on this input, the device automatically enters the aforementioned Unlock Bypass mode and uses the higher voltage on the input to reduce the time required for program operations. The system would use a two-cycle program command sequence as required by the Unlock Bypass mode. Removing  $V_{HH}$  from the ACC input returns the device to normal operation. Note that sectors must be unlocked prior to raising ACC to  $V_{HH}$ . *Note that the ACC pin must not be at  $V_{HH}$  for operations other than accelerated programming, or device damage may result. In addition, the ACC pin must not be left floating or unconnected; inconsistent behavior of the device may result.*

When at  $V_{IL}$ , ACC locks all sectors. ACC should be at  $V_{IH}$  for all other conditions.

## Autoselect Mode

The autoselect mode provides manufacturer and device identification, and sector protection verification, through identifier codes output from the internal register (which is separate from the memory array) on DQ15–DQ0. This mode is primarily intended for programming equipment to automatically match a device to be programmed with its corresponding programming algorithm. However, the autoselect codes can also be accessed in-system through the command register.

When using programming equipment, the autoselect mode requires  $V_{ID}$  on address pin A9. Address pins must be as shown in [Table 3, “Autoselect Codes \(High Voltage Method\),” on page 18](#). In addition, when verifying sector protection, the sector address must appear on the appropriate highest order address bits (see [Table , “,” on page 18](#) and [Table , “,” on page 21](#)). [Table 3](#) shows the remaining address bits that are don’t care. When all necessary bits have been set as required, the programming equipment may then read the corresponding identifier code on DQ15–DQ0. However, the autoselect codes can also be accessed in-system through the command register, for instances when the device is erased or programmed in a system without access to high voltage on the A9 pin. The command sequence is illustrated in [Table 18, “Command Definitions,” on page 60](#). *Note that if a Bank Address (BA) on address bits A22, A21, and A20 for the WS128J (A21:A19 for the WS064J) is asserted during the third write cycle of the autoselect command, the host system can read autoselect data that bank and then immediately read array data from the other bank, without exiting the autoselect mode.*

To access the autoselect codes in-system, the host system can issue the autoselect command via the command register, as shown in [Table 18, “Command Definitions,” on page 60](#). This method does not require  $V_{ID}$ . Autoselect mode may only be entered and used when in the asynchronous read mode. Refer to the “Autoselect Command Sequence” section on page 51 for more information.

**Table 3. Autoselect Codes (High Voltage Method)**

Description	CE#	OE#	WE#	RESET#	Amax to A12	A11 to A10	A9	A8	A7	A6	A5 to A4	A3	A2	A1	A0	DQ15 to DQ0
Manufacturer ID: Spansion	L	L	H	H	X	X	V <sub>ID</sub>	X	X	L	X	L	L	L	L	0001h
Device ID	Read Cycle 1	L	L	H	H	X	X	V <sub>ID</sub>	X	L	L	L	L	L	H	227Eh
	Read Cycle 2											H	H	H	L	2218h (WS128J) 221Eh (WS064J)
	Read Cycle 3											H	H	H	H	2200h (WS128J) 2201h (WS064J)
Sector Protection Verification	L	L	H	H	SA	X	V <sub>ID</sub>	X	L	L	L	L	L	H	L	0001h (protected), 0000h (unprotected)
Indicator Bits	L	L	H	H	X	X	V <sub>ID</sub>	X	X	L	X	L	L	H	H	DQ15 - DQ8 = 0 DQ7 - Factory Lock Bit 1 = Locked, 0 = Not Locked DQ6 - Customer Lock Bit 1 = Locked, 0 = Not Locked DQ5 = Handshake Bit 1 = Reserved, 0 = Standard Handshake DQ4 & DQ3 - Boot Code DQ2 - DQ0 = 001
Hardware Sector Group Protection	L	L	H	H	SA	X	V <sub>ID</sub>	X	X	X	L	L	L	H	L	0001h (protected), 0000h (unprotected)

**Legend:** L = Logic Low = V<sub>IL</sub>, H = Logic High = V<sub>IH</sub>, BA = Bank Address, SA = Sector Address, X = Don't care.

**Notes:**

1. The autoselect codes may also be accessed in-system via command sequences.
2. PPB Protection Status is shown on the data bus

**Sector/Sector Block Protection and Unprotection**

The hardware sector protection feature disables both programming and erase operations in any sector. The hardware sector unprotection feature re-enables both program and erase operations in previously protected sectors. Sector protection/unprotection can be implemented via two methods.

(Note: For the following discussion, the term "sector" applies to both sectors and sector blocks. A sector block consists of two or more adjacent sectors that are protected or unprotected at the same time (see Table , " on page 18 and Table , " on page 21).)

**Table 4. S29WSI28J/064J Boot Sector/Sector Block Addresses for Protection/Unprotection (Sheet I of 3)**

Sector	A22-A12	Sector/ Sector Block Size
SA0	00000000000	4 Kwords
SA1	00000000001	4 Kwords
SA2	00000000010	4 Kwords
SA3	00000000011	4 Kwords
SA4	00000000100	4 Kwords
SA5	00000000101	4 Kwords
SA6	00000000110	4 Kwords
SA7	00000000111	4 Kwords
SA8	00000001XXX,	32 Kwords
SA9	00000010XXX,	32 Kwords
SA10	00000011XXX,	32 Kwords

**Table 4. S29WSI28J/064J Boot Sector/Sector Block Addresses for Protection/Unprotection (Sheet 2 of 3)**

Sector	A22-A12	Sector/ Sector Block Size
SA11-SA14	000001XXXXX	128 (4x32) Kwords
SA15-SA18	000010XXXXX	128 (4x32) Kwords
SA19-SA22	000011XXXXX	128 (4x32) Kwords
SA23-SA26	000100XXXXX	128 (4x32) Kwords
SA27-SA30	000101XXXXX	128 (4x32) Kwords
SA31-SA34	000110XXXXX	128 (4x32) Kwords
SA35-SA38	000111XXXXX	128 (4x32) Kwords
SA39-SA42	001000XXXXX	128 (4x32) Kwords
SA43-SA46	001001XXXXX	128 (4x32) Kwords
SA47-SA50	001010XXXXX	128 (4x32) Kwords
SA51-SA54	001011XXXXX	128 (4x32) Kwords
SA55-SA58	001100XXXXX	128 (4x32) Kwords
SA59-SA62	001101XXXXX	128 (4x32) Kwords
SA63-SA66	001110XXXXX	128 (4x32) Kwords
SA67-SA70	001111XXXXX	128 (4x32) Kwords
SA71-SA74	010000XXXXX	128 (4x32) Kwords
SA75-SA78	010001XXXXX	128 (4x32) Kwords
SA79-SA82	010010XXXXX	128 (4x32) Kwords
SA83-SA86	010011XXXXX	128 (4x32) Kwords
SA87-SA90	010100XXXXX	128 (4x32) Kwords
SA91-SA94	010101XXXXX	128 (4x32) Kwords
SA95-SA98	010110XXXXX	128 (4x32) Kwords
SA99-SA102	010111XXXXX	128 (4x32) Kwords
SA103-SA106	011000XXXXX	128 (4x32) Kwords
SA107-SA110	011001XXXXX	128 (4x32) Kwords
SA111-SA114	011010XXXXX	128 (4x32) Kwords
SA115-SA118	011011XXXXX	128 (4x32) Kwords
SA119-SA122	011100XXXXX	128 (4x32) Kwords
SA123-SA126	011101XXXXX	128 (4x32) Kwords
SA127-SA130	011110XXXXX	128 (4x32) Kwords
SA131-SA134	011111XXXXX	128 (4x32) Kwords
SA135-SA138	100000XXXXX	128 (4x32) Kwords
SA139-SA142	100001XXXXX	128 (4x32) Kwords
SA143-SA146	100010XXXXX	128 (4x32) Kwords
SA147-SA150	100011XXXXX	128 (4x32) Kwords
SA151-SA154	100100XXXXX	128 (4x32) Kwords
SA155-SA158	100101XXXXX	128 (4x32) Kwords
SA159-SA162	100110XXXXX	128 (4x32) Kwords
SA163-SA166	100111XXXXX	128 (4x32) Kwords

**Table 4. S29WSI28J/064J Boot Sector/Sector Block Addresses for Protection/Unprotection (Sheet 3 of 3)**

Sector	A22-A12	Sector/ Sector Block Size
SA167-SA170	101000XXXXX	128 (4x32) Kwords
SA171-SA174	101001XXXXX	128 (4x32) Kwords
SA175-SA178	101010XXXXX	128 (4x32) Kwords
SA179-SA182	101011XXXXX	128 (4x32) Kwords
SA183-SA186	101100XXXXX	128 (4x32) Kwords
SA187-SA190	101101XXXXX	128 (4x32) Kwords
SA191-SA194	101110XXXXX	128 (4x32) Kwords
SA195-SA198	101111XXXXX	128 (4x32) Kwords
SA199-SA202	110000XXXXX	128 (4x32) Kwords
SA203-SA206	110001XXXXX	128 (4x32) Kwords
SA207-SA210	110010XXXXX	128 (4x32) Kwords
SA211-SA214	110011XXXXX	128 (4x32) Kwords
SA215-SA218	110100XXXXX	128 (4x32) Kwords
SA219-SA222	110101XXXXX	128 (4x32) Kwords
SA223-SA226	110110XXXXX	128 (4x32) Kwords
SA227-SA230	110111XXXXX	128 (4x32) Kwords
SA231-SA234	111000XXXXX	128 (4x32) Kwords
SA235-SA238	111001XXXXX	128 (4x32) Kwords
SA239-SA242	111010XXXXX	128 (4x32) Kwords
SA243-SA246	111011XXXXX	128 (4x32) Kwords
SA247-SA250	111100XXXXX	128 (4x32) Kwords
SA251-SA254	111101XXXXX	128 (4x32) Kwords
SA255-SA258	111110XXXXX	128 (4x32) Kwords
SA259	11111100XXX	32 Kwords
SA260	11111101XXX	32 Kwords
SA261	11111110XXX	32 Kwords
SA262	11111111000	4 Kwords
SA263	11111111001	4 Kwords
SA264	11111111010	4 Kwords
SA265	11111111011	4 Kwords
SA266	11111111100	4 Kwords
SA267	11111111101	4 Kwords
SA268	11111111110	4 Kwords
SA269	11111111111	4 Kwords

**Table 5. S29WS064J Boot Sector/Sector Block Addresses for Protection/Unprotection (Sheet 1 of 2)**

Sector	A21-A12	Sector/ Sector Block Size
SA0	000000000	4 Kwords
SA1	000000001	4 Kwords
SA2	000000010	4 Kwords
SA3	000000011	4 Kwords
SA4	000000100	4 Kwords
SA5	000000101	4 Kwords
SA6	000000110	4 Kwords
SA7	000000111	4 Kwords
SA8	000001XXX	32 Kwords
SA9	000010XXX	32 Kwords
SA10	000011XXX	32 Kwords
SA11-SA14	00001XXXXX	128 (4x32) Kwords
SA15-SA18	00010XXXXX	128 (4x32) Kwords
SA19-SA22	00011XXXXX	128 (4x32) Kwords
SA23-SA26	00100XXXXX	128 (4x32) Kwords
SA27-SA30	00101XXXXX	128 (4x32) Kwords
SA31-SA34	00110XXXXX	128 (4x32) Kwords
SA35-SA38	00111XXXXX	128 (4x32) Kwords
SA39-SA42	01000XXXXX	128 (4x32) Kwords
SA43-SA46	01001XXXXX	128 (4x32) Kwords
SA47-SA50	01010XXXXX	128 (4x32) Kwords
SA51-SA54	01011XXXXX	128 (4x32) Kwords
SA55-SA58	01100XXXXX	128 (4x32) Kwords
SA59-SA62	01101XXXXX	128 (4x32) Kwords
SA63-SA66	01110XXXXX	128 (4x32) Kwords
SA67-SA70	01111XXXXX	128 (4x32) Kwords
SA71-SA74	10000XXXXX	128 (4x32) Kwords
SA75-SA78	10001XXXXX	128 (4x32) Kwords
SA79-SA82	10010XXXXX	128 (4x32) Kwords
SA83-SA86	10011XXXXX	128 (4x32) Kwords
SA87-SA90	10100XXXXX	128 (4x32) Kwords
SA91-SA94	10101XXXXX	128 (4x32) Kwords
SA95-SA98	10110XXXXX	128 (4x32) Kwords
SA99-SA102	10111XXXXX	128 (4x32) Kwords
SA103-SA106	11000XXXXX	128 (4x32) Kwords
SA107-SA110	11001XXXXX	128 (4x32) Kwords
SA111-SA114	11010XXXXX	128 (4x32) Kwords
SA115-SA118	11011XXXXX	128 (4x32) Kwords
SA119-SA122	11100XXXXX	128 (4x32) Kwords

**Table 5. S29WS064J Boot Sector/Sector Block Addresses for Protection/Unprotection (Sheet 2 of 2)**

Sector	A21-A12	Sector/ Sector Block Size
SA123-SA126	11101XXXXX	128 (4x32) Kwords
SA127-SA130	11110XXXXX	128 (4x32) Kwords
SA131	1111100XXX	32 Kwords
SA132	1111101XXX	32 Kwords
SA133	1111110XXX	32 Kwords
SA134	1111111000	4 Kwords
SA135	1111111001	4 Kwords
SA136	1111111010	4 Kwords
SA137	1111111011	4 Kwords
SA138	1111111100	4 Kwords
SA139	1111111101	4 Kwords
SA140	1111111110	4 Kwords
SA141	1111111111	4 Kwords

## Advanced Sector Protection/Unprotection

The Advanced Sector Protection/Unprotection feature disables or enables programming or erase operations in any or all sectors and can be implemented through software and/or hardware methods, which are independent of each other. This section describes the various methods of protecting data stored in the memory array. An overview of these methods is shown in Figure 1.

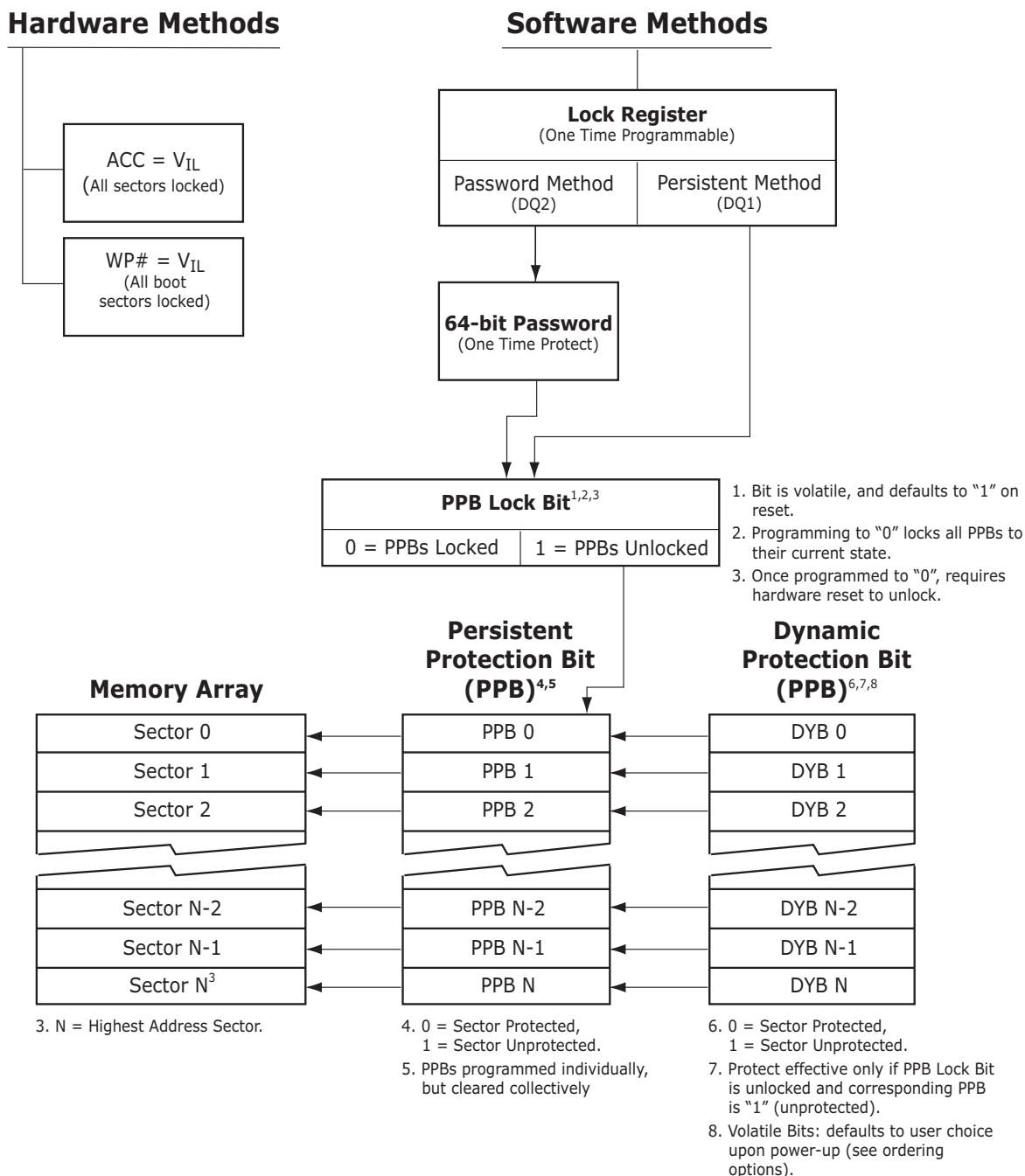

Figure 1. Advanced Sector Protection/Unprotection

## Lock Register

As shipped from the factory, all devices default to the persistent mode when power is applied, and all sectors are unprotected, unless otherwise chosen through the DYB ordering option. The device programmer or host system must then choose which sector protection method to use. Programming (setting to "0") any one of the following two one-time programmable, non-volatile bits locks the part permanently in that mode:

- Lock Register Persistent Protection Mode Lock Bit (DQ1)
- Lock Register Password Protection Mode Lock Bit (DQ2)

**Table 6. Lock Register**

Device	DQ15-05	DQ4	DQ3	DQ2	DQ1	DQ0
S29WS256N	1	1	1	Password Protection Mode Lock Bit	Persistent Protection Mode Lock Bit	Customer SecSi Sector Protection Bit
S29WS128N/ S29WS064N	Undefined	DYB Lock Boot Bit 0 = sectors power up protected 1 = sectors power up unprotected	PPB One-Time Programmable Bit 0 = All PPB erase command disabled 1 = All PPB Erase command enabled	Password Protection Mode Lock Bit	Persistent Protection Mode Lock Bit	SecSi Sector Protection Bit

### Notes

1. If the password mode is chosen, the password must be programmed before setting the corresponding lock register bit.
2. After the Lock Register Bits Command Set Entry command sequence is written, reads and writes for Bank 0 are disabled, while reads from other banks are allowed until exiting this mode.
3. If both lock bits are selected to be programmed (to zeros) at the same time, the operation aborts.
4. Once the Password Mode Lock Bit is programmed, the Persistent Mode Lock Bit is permanently disabled, and no changes to the protection scheme are allowed. Similarly, if the Persistent Mode Lock Bit is programmed, the Password Mode is permanently disabled.

After selecting a sector protection method, each sector can operate in any of the following three states:

1. *Constantly locked.* The selected sectors are protected and can not be reprogrammed unless PPB lock bit is cleared via a password, hardware reset, or power cycle.
2. *Dynamically locked.* The selected sectors are protected and can be altered via software commands.
3. *Unlocked.* The sectors are unprotected and can be erased and/or programmed.

These states are controlled by the bit types described in Sections –.

## Persistent Protection Bits

The Persistent Protection Bits are unique and nonvolatile for each sector and have the same endurance as the Flash memory. Preprogramming and verification prior to erasure are handled by the device, and therefore do not require system monitoring.

### Notes

1. Each PPB is individually programmed and all are erased in parallel.
2. While programming PPB for a sector, array data can be read from any other bank, except Bank 0 (used for Data# Polling) and the bank in which sector PPB is being programmed.
3. Entry command disables reads and writes for the bank selected.
4. Reads within that bank return the PPB status for that sector.
5. Reads from other banks are allowed while writes are not allowed.



6. All Reads must be performed using the Asynchronous mode.
7. The specific sector address (A23-A14 WS256N, A22-A14 WS128N, A21-A14 WS064N) are written at the same time as the program command.
8. If the PPB Lock Bit is set, the PPB Program or erase command does not execute and times-out without programming or erasing the PPB.
9. There are no means for individually erasing a specific PPB and no specific sector address is required for this operation.
10. Exit command must be issued after the execution which resets the device to read mode and re-enables reads and writes for Bank 0
11. The programming state of the PPB for a given sector can be verified by writing a PPB Status Read Command to the device as described by the flow chart shown in [Figure 2](#).

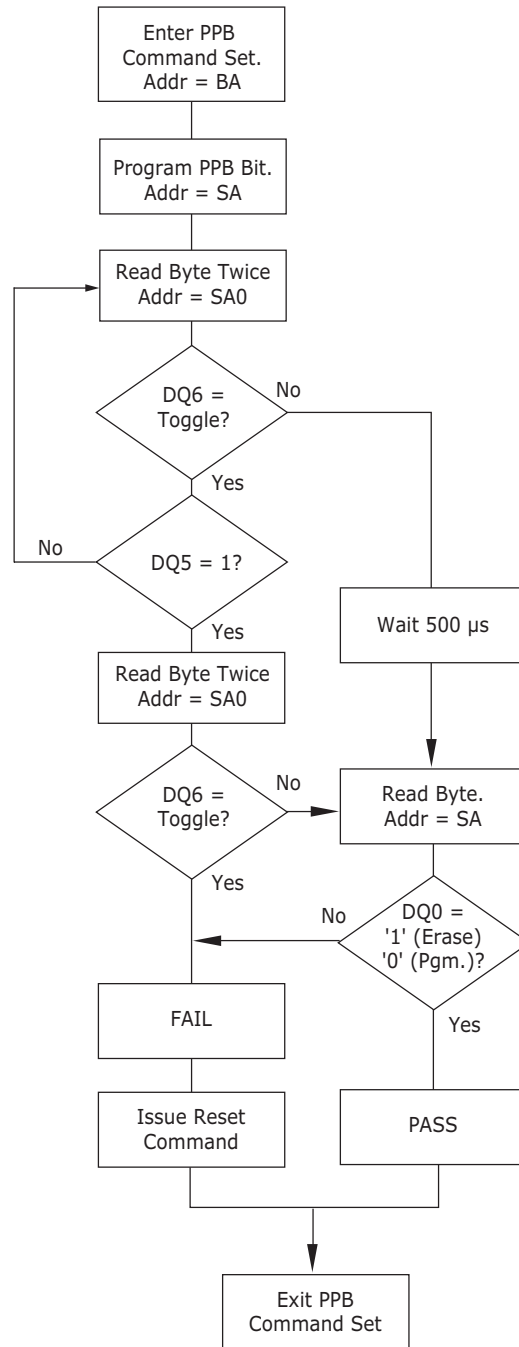

Figure 2. PPB Program/Erase Algorithm

### Dynamic Protection Bits

Dynamic Protection Bits are volatile and unique for each sector and can be individually modified. DYBs only control the protection scheme for unprotected sectors that have their PPBs cleared (erased to "1"). By issuing the DYB Set or Clear command sequences, the DYBs are set (programmed to "0") or cleared (erased to "1"), thus placing each sector in the protected or unprotected state respectively. This feature allows software to easily protect sectors against inadvertent changes yet does not prevent the easy removal of protection when changes are needed.

**Notes**

1. The DYBs can be set (programmed to "0") or cleared (erased to "1") as often as needed. When the parts are first shipped, the PPBs are cleared (erased to "1") and upon power up or reset, the DYBs can be set or cleared depending upon the ordering option chosen.
2. If the option to clear the DYBs after power up is chosen, (erased to "1"), then the sectors may be modified depending upon the PPB state of that sector (see [Table 7](#)).
3. The sectors would be in the protected state if the option to set the DYBs after power up is chosen (programmed to "0").
4. It is possible to have sectors that are persistently locked with sectors that are left in the dynamic state.
5. The DYB Set or Clear commands for the dynamic sectors signify protected or unprotected state of the sectors respectively. However, if there is a need to change the status of the persistently locked sectors, a few more steps are required. First, the PPB Lock Bit must be cleared by either putting the device through a power-cycle, or hardware reset. The PPBs can then be changed to reflect the desired settings. Setting the PPB Lock Bit once again locks the PPBs, and the device operates normally again.
6. To achieve the best protection, it is recommended to execute the PPB Lock Bit Set command early in the boot code and protect the boot code by holding  $WP\# = V_{IL}$ . Note that the PPB and DYB bits have the same function when  $ACC = V_{HH}$  as they do when  $ACC = V_{IH}$ .

**Persistent Protection Bit Lock Bit**

The Persistent Protection Bit Lock Bit is a global volatile bit for all sectors. When set (programmed to "0"), it locks all PPBs and when cleared (programmed to "1"), allows the PPBs to be changed. There is only one PPB Lock Bit per device.

**Notes**

1. No software command sequence unlocks this bit unless the device is in the password protection mode; only a hardware reset or a power-up clears this bit.
2. The PPB Lock Bit must be set (programmed to "0") only after all PPBs are configured to the desired settings.

**Password Protection Method**

The Password Protection Method allows an even higher level of security than the Persistent Sector Protection Mode by requiring a 64 bit password for unlocking the device PPB Lock Bit. In addition to this password requirement, after power up and reset, the PPB Lock Bit is set "0" to maintain the password mode of operation. Successful execution of the Password Unlock command by entering the entire password clears the PPB Lock Bit, allowing for sector PPBs modifications.

**Notes**

1. There is no special addressing order required for programming the password. Once the Password is written and verified, the Password Mode Locking Bit must be set in order to prevent access.
2. The Password Program Command is only capable of programming "0"s. Programming a "1" after a cell is programmed as a "0" results in a time-out with the cell as a "0".
3. The password is all "1"s when shipped from the factory.
4. All 64-bit password combinations are valid as a password.
5. There is no means to verify what the password is after it is set.
6. The Password Mode Lock Bit, once set, prevents reading the 64-bit password on the data bus and further password programming.
7. The Password Mode Lock Bit is not erasable.
8. The lower two address bits (A1–A0) are valid during the Password Read, Password Program, and Password Unlock.
9. The exact password must be entered in order for the unlocking function to occur.

10. The Password Unlock command cannot be issued any faster than 1  $\mu$ s at a time to prevent a hacker from running through all the 64-bit combinations in an attempt to correctly match a password.
11. Approximately 1  $\mu$ s is required for unlocking the device after the valid 64-bit password is given to the device.
12. Password verification is only allowed during the password programming operation.
13. All further commands to the password region are disabled and all operations are ignored.
14. If the password is lost after setting the Password Mode Lock Bit, there is no way to clear the PPB Lock Bit.
15. Entry command sequence must be issued prior to any of any operation and it disables reads and writes for Bank 0. Reads and writes for other banks excluding Bank 0 are allowed.
16. If the user attempts to program or erase a protected sector, the device ignores the command and returns to read mode.
17. A program or erase command to a protected sector enables status polling and returns to read mode without having modified the contents of the protected sector.
18. The programming of the DYB, PPB, and PPB Lock for a given sector can be verified by writing individual status read commands DYB Status, PPB Status, and PPB Lock Status to the device.

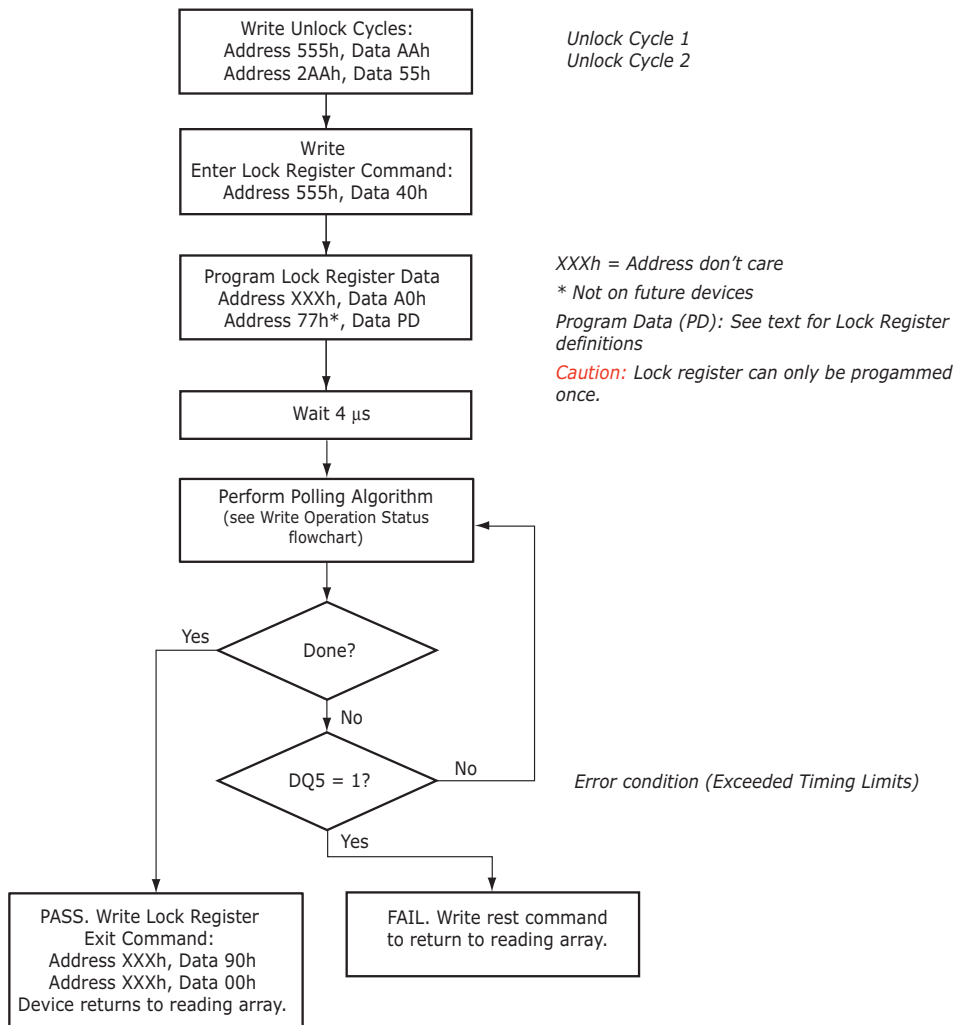

Figure 3. Lock Register Program Algorithm

## Advanced Sector Protection Software Examples

Table 7. Sector Protection Schemes

Unique Device PPB Lock Bit 0 = locked 1 = unlocked		Sector PPB 0 = protected 1 = unprotected	Sector DYB 0 = protected 1 = unprotected	Sector Protection Status
Any Sector	0	0	x	Protected through PPB
Any Sector	0	0	x	Protected through PPB
Any Sector	0	1	1	Unprotected
Any Sector	0	1	0	Protected through DYB
Any Sector	1	0	x	Protected through PPB
Any Sector	1	0	x	Protected through PPB
Any Sector	1	1	0	Protected through DYB
Any Sector	1	1	1	Unprotected

Table 7 contains all possible combinations of the DYB, PPB, and PPB Lock Bit relating to the status of the sector. In summary, if the PPB Lock Bit is locked (set to "0"), no changes to the PPBs are allowed. The PPB Lock Bit can only be unlocked (reset to "1") through a hardware reset or power cycle. See also Figure 1 for an overview of the Advanced Sector Protection feature.

### Hardware Data Protection Methods

The device offers two main types of data protection at the sector level via hardware control:

- When WP# is at  $V_{IL}$ , the four outermost sectors are locked (device specific).
- When ACC is at  $V_{IL}$ , all sectors are locked.

There are additional methods by which intended or accidental erasure of any sectors can be prevented via hardware means. The following subsections describes these methods:

#### WP# Method

The Write Protect feature provides a hardware method of protecting the four outermost sectors. This function is provided by the WP# pin and overrides the previously discussed Sector Protection/Unprotection method.

If the system asserts  $V_{IL}$  on the WP# pin, the device disables program and erase functions in the "outermost" boot sectors. The outermost boot sectors are the sectors containing both the lower and upper set of sectors in a dual-boot-configured device.

If the system asserts  $V_{IH}$  on the WP# pin, the device reverts to whether the boot sectors were last set to be protected or unprotected. That is, sector protection or unprotection for these sectors depends on whether they were last protected or unprotected.

Note that the WP# pin must not be left floating or unconnected as inconsistent behavior of the device may result.

The WP# pin must be held stable during a command sequence execution

#### ACC Method

This method is similar to above, except it protects all sectors. Once ACC input is set to  $V_{IL}$ , all program and erase functions are disabled and hence all sectors are protected.

#### Low $V_{CC}$ Write Inhibit

When  $V_{CC}$  is less than  $V_{LKO}$ , the device does not accept any write cycles. This protects data during  $V_{CC}$  power-up and power-down.

The command register and all internal program/erase circuits are disabled, and the device resets to reading array data. Subsequent writes are ignored until  $V_{CC}$  is greater than  $V_{LKO}$ . The system must provide the proper signals to the control inputs to prevent unintentional writes when  $V_{CC}$  is greater than  $V_{LKO}$ .

**Write Pulse “Glitch Protection”**

Noise pulses of less than 3 ns (typical) on OE#, CE# or WE# do not initiate a write cycle.

**Power-Up Write Inhibit**

If WE# = CE# = RESET# =  $V_{IL}$  and OE# =  $V_{IH}$  during power up, the device does not accept commands on the rising edge of WE#. The internal state machine is automatically reset to the read mode on power-up.

**Common Flash Memory Interface (CFI)**

The Common Flash Interface (CFI) specification outlines device and host system software interrogation handshake, which allows specific vendor-specified software algorithms to be used for entire families of devices. Software support can then be device-independent, JEDEC ID-independent, and forward- and backward-compatible for the specified flash device families. Flash vendors can standardize their existing interfaces for long-term compatibility.

This device enters the CFI Query mode when the system writes the CFI Query command, 98h, to address 55h any time the device is ready to read array data. The system can read CFI information at the addresses given in Tables 8-11. To terminate reading CFI data, the system must write the reset command.

The system can also write the CFI query command when the device is in the autoselect mode. The device enters the CFI query mode, and the system can read CFI data at the addresses given in Tables 8-11. The system must write the reset command to return the device to the autoselect mode.

**Table 8. CFI Query Identification String**

Addresses	Data	Description
10h 11h 12h	0051h 0052h 0059h	Query Unique ASCII string “QRY”
13h 14h	0002h 0000h	Primary OEM Command Set
15h 16h	0040h 0000h	Address for Primary Extended Table
17h 18h	0000h 0000h	Alternate OEM Command Set (00h = none exists)
19h 1Ah	0000h 0000h	Address for Alternate OEM Extended Table (00h = none exists)

**Table 9. System Interface String**

Addresses	Data	Description
1Bh	0017h	V <sub>CC</sub> Min. (write/erase) D7–D4: volt, D3–D0: 100 millivolt
1Ch	0019h	V <sub>CC</sub> Max. (write/erase) D7–D4: volt, D3–D0: 100 millivolt
1Dh	0000h	V <sub>pp</sub> Min. voltage (00h = no V <sub>pp</sub> pin present)
1Eh	0000h	V <sub>pp</sub> Max. voltage (00h = no V <sub>pp</sub> pin present)
1Fh	0003h	Typical timeout per single byte/word write 2 <sup>n</sup> μs
20h	0000h	Typical timeout for Min. size buffer write 2 <sup>n</sup> μs (00h = not supported)
21h	0009h	Typical timeout per individual block erase 2 <sup>n</sup> ms
22h	0000h	Typical timeout for full chip erase 2 <sup>n</sup> ms (00h = not supported)
23h	0004h	Max. timeout for byte/word write 2 <sup>n</sup> times typical
24h	0000h	Max. timeout for buffer write 2 <sup>n</sup> times typical
25h	0004h	Max. timeout per individual block erase 2 <sup>n</sup> times typical
26h	0000h	Max. timeout for full chip erase 2 <sup>n</sup> times typical (00h = not supported)

**Table 10. Device Geometry Definition**

Addresses	Data	Description
27h	0018h (WS128J) 0017h (WS064J)	Device Size = 2 <sup>n</sup> byte
28h 29h	0001h 0000h	Flash Device Interface description (refer to CFI publication 100)
2Ah 2Bh	0000h 0000h	Max. number of bytes in multi-byte write = 2 <sup>n</sup> (00h = not supported)
2Ch	0003h	Number of Erase Block Regions within device
2Dh 2Eh 2Fh 30h	0007h 0000h 0020h 0000h	Erase Block Region 1 Information (refer to the CFI specification or CFI publication 100)
31h	00FDh (WS128J) 007Dh (WS064J)	Erase Block Region 2 Information
32h 33h 34h	0000h 0000h 0001h	
35h 36h 37h 38h	0007h 0000h 0020h 0000h	
39h 3Ah 3Bh 3Ch	0000h 0000h 0000h 0000h	Erase Block Region 4 Information

**Table II. Primary Vendor-Specific Extended Query**

Addresses	Data	Description
40h 41h 42h	0050h 0052h 0049h	Query-unique ASCII string "PRI"
43h	0031h	Major version number, ASCII
44h	0033h	Minor version number, ASCII
45h	000Ch	Address Sensitive Unlock (Bits 1-0) 0 = Required, 1 = Not Required Silicon Technology (Bits 5-2) 0011 = 0.13 μm
46h	0002h	Erase Suspend 0 = Not Supported, 1 = To Read Only, 2 = To Read & Write
47h	0001h	Sector Protect 0 = Not Supported, X = Number of sectors in per group
48h	0001h	Sector Temporary Unprotect 00 = Not Supported, 01 = Supported
49h	0007h	Sector Protect/Unprotect scheme 07 = Advanced Sector Protection
4Ah	00E7h (WS128J) 0077h (WS064J)	Simultaneous Operation Number of Sectors in all banks except boot block
4Bh	0001h	Burst Mode Type 00 = Not Supported, 01 = Supported
4Ch	0000h	Page Mode Type 00 = Not Supported, 01 = 4 Word Page, 02 = 8 Word Page, 04 = 16 Word Page
4Dh	00B5h	ACC (Acceleration) Supply Minimum 00h = Not Supported, D7-D4: Volt, D3-D0: 100 mV
4Eh	00C5h	ACC (Acceleration) Supply Maximum 00h = Not Supported, D7-D4: Volt, D3-D0: 100 mV
4Fh	0001h	Top/Bottom Boot Sector Flag 01h = Dual Boot Device, 02h = Bottom Boot Device, 03h = Top Boot Device
50h	0000h	Program Suspend. 00h = not supported
57h	0004h	Bank Organization: X = Number of banks
58h	0027h (WS128J) 0017h (WS064J)	Bank A Region Information. X = Number of sectors in bank
59h	0060h (WS128J) 0030h (WS064J)	Bank B Region Information. X = Number of sectors in bank
5Ah	0060h (WS128J) 0030h (WS064J)	Bank C Region Information. X = Number of sectors in bank
5Bh	0027h (WS128J) 0017h (WS064J)	Bank D Region Information. X = Number of sectors in bank



Table I2. WSI28J Sector Address Table (Sheet I of 8)

Bank	Sector	Sector Size	(x16) Address Range
Bank D	SA0	4 Kwords	000000h-000FFFh
	SA1	4 Kwords	001000h-001FFFh
	SA2	4 Kwords	002000h-002FFFh
	SA3	4 Kwords	003000h-003FFFh
	SA4	4 Kwords	004000h-004FFFh
	SA5	4 Kwords	005000h-005FFFh
	SA6	4 Kwords	006000h-006FFFh
	SA7	4 Kwords	007000h-007FFFh
	SA8	32 Kwords	008000h-00FFFFFFh
	SA9	32 Kwords	010000h-017FFFh
	SA10	32 Kwords	018000h-01FFFFFFh
	SA11	32 Kwords	020000h-027FFFh
	SA12	32 Kwords	028000h-02FFFFFFh
	SA13	32 Kwords	030000h-037FFFh
	SA14	32 Kwords	038000h-03FFFFFFh
	SA15	32 Kwords	040000h-047FFFh
	SA16	32 Kwords	048000h-04FFFFFFh
	SA17	32 Kwords	050000h-057FFFh
	SA18	32 Kwords	058000h-05FFFFFFh
	SA19	32 Kwords	060000h-067FFFh
	SA20	32 Kwords	068000h-06FFFFFFh
	SA21	32 Kwords	070000h-077FFFh
	SA22	32 Kwords	078000h-07FFFFFFh
	SA23	32 Kwords	080000h-087FFFh
	SA24	32 Kwords	088000h-08FFFFFFh
	SA25	32 Kwords	090000h-097FFFh
	SA26	32 Kwords	098000h-09FFFFFFh
	SA27	32 Kwords	0A0000h-0A7FFFh
	SA28	32 Kwords	0A8000h-0AFFFFFFh
	SA29	32 Kwords	0B0000h-0B7FFFh
	SA30	32 Kwords	0B8000h-0BFFFFFFh
	SA31	32 Kwords	0C0000h-0C7FFFh
	SA32	32 Kwords	0C8000h-0CFFFFFFh
	SA33	32 Kwords	0D0000h-0D7FFFh
	SA34	32 Kwords	0D8000h-0DFFFFFFh
	SA35	32 Kwords	0E0000h-0E7FFFh
	SA36	32 Kwords	0E8000h-0EFFFFFFh
	SA37	32 Kwords	0F0000h-0F7FFFh
SA38	32 Kwords	0F8000h-0FFFFFFh	

**Table I2. WSI28J Sector Address Table (Sheet 2 of 8)**

Bank	Sector	Sector Size	(x16) Address Range
Bank C	SA39	32 Kwords	100000h-107FFFh
	SA40	32 Kwords	108000h-10FFFFh
	SA41	32 Kwords	110000h-117FFFh
	SA42	32 Kwords	118000h-11FFFFh
	SA43	32 Kwords	120000h-127FFFh
	SA44	32 Kwords	128000h-12FFFFh
	SA45	32 Kwords	130000h-137FFFh
	SA46	32 Kwords	138000h-13FFFFh
	SA47	32 Kwords	140000h-147FFFh
	SA48	32 Kwords	148000h-14FFFFh
	SA49	32 Kwords	150000h-157FFFh
	SA50	32 Kwords	158000h-15FFFFh
	SA51	32 Kwords	160000h-167FFFh
	SA52	32 Kwords	168000h-16FFFFh
	SA53	32 Kwords	170000h-177FFFh
	SA54	32 Kwords	178000h-17FFFFh
	SA55	32 Kwords	180000h-187FFFh
	SA56	32 Kwords	188000h-18FFFFh
	SA57	32 Kwords	190000h-197FFFh
	SA58	32 Kwords	198000h-19FFFFh
	SA59	32 Kwords	1A0000h-1A7FFFh
	SA60	32 Kwords	1A8000h-1AFFFFh
	SA61	32 Kwords	1B0000h-1B7FFFh
	SA62	32 Kwords	1B8000h-1BFFFFh
	SA63	32 Kwords	1C0000h-1C7FFFh
	SA64	32 Kwords	1C8000h-1CFFFFh
	SA65	32 Kwords	1D0000h-1D7FFFh
	SA66	32 Kwords	1D8000h-1DFFFFh
	SA67	32 Kwords	1E0000h-1E7FFFh
	SA68	32 Kwords	1E8000h-1EFFFFh
SA69	32 Kwords	1F0000h-1F7FFFh	
SA70	32 Kwords	1F8000h-1FFFFFh	

Table I2. WSI28J Sector Address Table (Sheet 3 of 8)

Bank	Sector	Sector Size	(x16) Address Range
Bank C	SA71	32 Kwords	200000h-207FFFh
	SA72	32 Kwords	208000h-20FFFFh
	SA73	32 Kwords	210000h-217FFFh
	SA74	32 Kwords	218000h-21FFFFh
	SA75	32 Kwords	220000h-227FFFh
	SA76	32 Kwords	228000h-22FFFFh
	SA77	32 Kwords	230000h-237FFFh
	SA78	32 Kwords	238000h-23FFFFh
	SA79	32 Kwords	240000h-247FFFh
	SA80	32 Kwords	248000h-24FFFFh
	SA81	32 Kwords	250000h-257FFFh
	SA82	32 Kwords	258000h-25FFFFh
	SA83	32 Kwords	260000h-267FFFh
	SA84	32 Kwords	268000h-26FFFFh
	SA85	32 Kwords	270000h-277FFFh
	SA86	32 Kwords	278000h-27FFFFh
	SA87	32 Kwords	280000h-287FFFh
	SA88	32 Kwords	288000h-28FFFFh
	SA89	32 Kwords	290000h-297FFFh
	SA90	32 Kwords	298000h-29FFFFh
	SA91	32 Kwords	2A0000h-2A7FFFh
	SA92	32 Kwords	2A8000h-2AFFFFh
	SA93	32 Kwords	2B0000h-2B7FFFh
	SA94	32 Kwords	2B8000h-2BFFFFh
	SA95	32 Kwords	2C0000h-2C7FFFh
	SA96	32 Kwords	2C8000h-2CFFFFh
	SA97	32 Kwords	2D0000h-2D7FFFh
	SA98	32 Kwords	2D8000h-2DFFFFh
	SA99	32 Kwords	2E0000h-2E7FFFh
	SA100	32 Kwords	2E8000h-2EFFFFh
	SA101	32 Kwords	2F0000h-2F7FFFh
	SA102	32 Kwords	2F8000h-2FFFFFh

**Table I2. WSI28J Sector Address Table (Sheet 4 of 8)**

Bank	Sector	Sector Size	(x16) Address Range
Bank C	SA103	32 Kwords	300000h-307FFFh
	SA104	32 Kwords	308000h-30FFFFh
	SA105	32 Kwords	310000h-317FFFh
	SA106	32 Kwords	318000h-31FFFFh
	SA107	32 Kwords	320000h-327FFFh
	SA108	32 Kwords	328000h-32FFFFh
	SA109	32 Kwords	330000h-337FFFh
	SA110	32 Kwords	338000h-33FFFFh
	SA111	32 Kwords	340000h-347FFFh
	SA112	32 Kwords	348000h-34FFFFh
	SA113	32 Kwords	350000h-357FFFh
	SA114	32 Kwords	358000h-35FFFFh
	SA115	32 Kwords	360000h-367FFFh
	SA116	32 Kwords	368000h-36FFFFh
	SA117	32 Kwords	370000h-377FFFh
	SA118	32 Kwords	378000h-37FFFFh
	SA119	32 Kwords	380000h-387FFFh
	SA120	32 Kwords	388000h-38FFFFh
	SA121	32 Kwords	390000h-397FFFh
	SA122	32 Kwords	398000h-39FFFFh
	SA123	32 Kwords	3A0000h-3A7FFFh
	SA124	32 Kwords	3A8000h-3AFFFFh
SA125	32 Kwords	3B0000h-3B7FFFh	
SA126	32 Kwords	3B8000h-3BFFFFh	
SA127	32 Kwords	3C0000h-3C7FFFh	
SA128	32 Kwords	3C8000h-3CFFFFh	
SA129	32 Kwords	3D0000h-3D7FFFh	
SA130	32 Kwords	3D8000h-3DFFFFh	
SA131	32 Kwords	3E0000h-3E7FFFh	
SA132	32 Kwords	3E8000h-3EFFFFh	
SA133	32 Kwords	3F0000h-3F7FFFh	
SA134	32 Kwords	3F8000h-3FFFFFh	

Table I2. WSI28J Sector Address Table (Sheet 5 of 8)

Bank	Sector	Sector Size	(x16) Address Range
Bank B	SA135	32 Kwords	400000h-407FFFh
	SA136	32 Kwords	408000h-40FFFFh
	SA137	32 Kwords	410000h-417FFFh
	SA138	32 Kwords	418000h-41FFFFh
	SA139	32 Kwords	420000h-427FFFh
	SA140	32 Kwords	428000h-42FFFFh
	SA141	32 Kwords	430000h-437FFFh
	SA142	32 Kwords	438000h-43FFFFh
	SA143	32 Kwords	440000h-447FFFh
	SA144	32 Kwords	448000h-44FFFFh
	SA145	32 Kwords	450000h-457FFFh
	SA146	32 Kwords	458000h-45FFFFh
	SA147	32 Kwords	460000h-467FFFh
	SA148	32 Kwords	468000h-46FFFFh
	SA149	32 Kwords	470000h-477FFFh
	SA150	32 Kwords	478000h-47FFFFh
	SA151	32 Kwords	480000h-487FFFh
	SA152	32 Kwords	488000h-48FFFFh
	SA153	32 Kwords	490000h-497FFFh
	SA154	32 Kwords	498000h-49FFFFh
	SA155	32 Kwords	4A0000h-4A7FFFh
	SA156	32 Kwords	4A8000h-4AFFFFh
	SA157	32 Kwords	4B0000h-4B7FFFh
	SA158	32 Kwords	4B8000h-4BFFFFh
	SA159	32 Kwords	4C0000h-4C7FFFh
	SA160	32 Kwords	4C8000h-4CFFFFh
	SA161	32 Kwords	4D0000h-4D7FFFh
	SA162	32 Kwords	4D8000h-4DFFFFh
	SA163	32 Kwords	4E0000h-4E7FFFh
	SA164	32 Kwords	4E8000h-4EFFFFh
	SA165	32 Kwords	4F0000h-4F7FFFh
	SA166	32 Kwords	4F8000h-4FFFFFh

**Table I2. WSI28J Sector Address Table (Sheet 6 of 8)**

Bank	Sector	Sector Size	(x16) Address Range
Bank B	SA167	32 Kwords	500000h-507FFFh
	SA168	32 Kwords	508000h-50FFFFh
	SA169	32 Kwords	510000h-517FFFh
	SA170	32 Kwords	518000h-51FFFFh
	SA171	32 Kwords	520000h-527FFFh
	SA172	32 Kwords	528000h-52FFFFh
	SA173	32 Kwords	530000h-537FFFh
	SA174	32 Kwords	538000h-53FFFFh
	SA175	32 Kwords	540000h-547FFFh
	SA176	32 Kwords	548000h-54FFFFh
	SA177	32 Kwords	550000h-557FFFh
	SA178	32 Kwords	558000h-55FFFFh
	SA179	32 Kwords	560000h-567FFFh
	SA180	32 Kwords	568000h-56FFFFh
	SA181	32 Kwords	570000h-577FFFh
	SA182	32 Kwords	578000h-57FFFFh
	SA183	32 Kwords	580000h-587FFFh
	SA184	32 Kwords	588000h-58FFFFh
	SA185	32 Kwords	590000h-597FFFh
	SA186	32 Kwords	598000h-59FFFFh
	SA187	32 Kwords	5A0000h-5A7FFFh
	SA188	32 Kwords	5A8000h-5AFFFFh
	SA189	32 Kwords	5B0000h-5B7FFFh
	SA190	32 Kwords	5B8000h-5BFFFFh
	SA191	32 Kwords	5C0000h-5C7FFFh
	SA192	32 Kwords	5C8000h-5CFFFFh
	SA193	32 Kwords	5D0000h-5D7FFFh
	SA194	32 Kwords	5D8000h-5DFFFFh
	SA195	32 Kwords	5E0000h-5E7FFFh
	SA196	32 Kwords	5E8000h-5EFFFFh
	SA197	32 Kwords	5F0000h-5F7FFFh
	SA198	32 Kwords	5F8000h-5FFFFFh

Table I2. WSI28J Sector Address Table (Sheet 7 of 8)

Bank	Sector	Sector Size	(x16) Address Range
Bank B	SA199	32 Kwords	600000h-607FFFh
	SA200	32 Kwords	608000h-60FFFFh
	SA201	32 Kwords	610000h-617FFFh
	SA202	32 Kwords	618000h-61FFFFh
	SA203	32 Kwords	620000h-627FFFh
	SA204	32 Kwords	628000h-62FFFFh
	SA205	32 Kwords	630000h-637FFFh
	SA206	32 Kwords	638000h-63FFFFh
	SA207	32 Kwords	640000h-647FFFh
	SA208	32 Kwords	648000h-64FFFFh
	SA209	32 Kwords	650000h-657FFFh
	SA210	32 Kwords	658000h-65FFFFh
	SA211	32 Kwords	660000h-667FFFh
	SA212	32 Kwords	668000h-66FFFFh
	SA213	32 Kwords	670000h-677FFFh
	SA214	32 Kwords	678000h-67FFFFh
	SA215	32 Kwords	680000h-687FFFh
	SA216	32 Kwords	688000h-68FFFFh
	SA217	32 Kwords	690000h-697FFFh
	SA218	32 Kwords	698000h-69FFFFh
	SA219	32 Kwords	6A0000h-6A7FFFh
	SA220	32 Kwords	6A8000h-6AFFFFh
	SA221	32 Kwords	6B0000h-6B7FFFh
	SA222	32 Kwords	6B8000h-6BFFFFh
	SA223	32 Kwords	6C0000h-6C7FFFh
	SA224	32 Kwords	6C8000h-6CFFFFh
	SA225	32 Kwords	6D0000h-6D7FFFh
	SA226	32 Kwords	6D8000h-6DFFFFh
	SA227	32 Kwords	6E0000h-6E7FFFh
	SA228	32 Kwords	6E8000h-6EFFFFh
SA229	32 Kwords	6F0000h-6F7FFFh	
SA230	32 Kwords	6F8000h-6FFFFFh	

**Table I2. WSI28J Sector Address Table (Sheet 8 of 8)**

Bank	Sector	Sector Size	(x16) Address Range
Bank A	SA231	32 Kwords	70000h-707FFFh
	SA232	32 Kwords	708000h-70FFFFh
	SA233	32 Kwords	710000h-717FFFh
	SA234	32 Kwords	718000h-71FFFFh
	SA235	32 Kwords	720000h-727FFFh
	SA236	32 Kwords	728000h-72FFFFh
	SA237	32 Kwords	730000h-737FFFh
	SA238	32 Kwords	738000h-73FFFFh
	SA239	32 Kwords	740000h-747FFFh
	SA240	32 Kwords	748000h-74FFFFh
	SA241	32 Kwords	750000h-757FFFh
	SA242	32 Kwords	758000h-75FFFFh
	SA243	32 Kwords	760000h-767FFFh
	SA244	32 Kwords	768000h-76FFFFh
	SA245	32 Kwords	770000h-777FFFh
	SA246	32 Kwords	778000h-77FFFFh
	SA247	32 Kwords	780000h-787FFFh
	SA248	32 Kwords	788000h-78FFFFh
	SA249	32 Kwords	790000h-797FFFh
	SA250	32 Kwords	798000h-79FFFFh
	SA251	32 Kwords	7A0000h-7A7FFFh
	SA252	32 Kwords	7A8000h-7AFFFFh
	SA253	32 Kwords	7B0000h-7B7FFFh
	SA254	32 Kwords	7B8000h-7BFFFFh
	SA255	32 Kwords	7C0000h-7C7FFFh
	SA256	32 Kwords	7C8000h-7CFFFFh
	SA257	32 Kwords	7D0000h-7D7FFFh
	SA258	32 Kwords	7D8000h-7DFFFFh
	SA259	32 Kwords	7E0000h-7E7FFFh
	SA260	32 Kwords	7E8000h-7EFFFFh
SA261	32 Kwords	7F0000h-7F7FFFh	
SA262	4 Kwords	7F8000h-7F8FFFh	
SA263	4 Kwords	7F9000h-7F9FFFh	
SA264	4 Kwords	7FA000h-7FAFFFh	
SA265	4 Kwords	7FB000h-7FBFFFh	
SA266	4 Kwords	7FC000h-7FCFFFh	
SA267	4 Kwords	7FD000h-7FDFFFh	
SA268	4 Kwords	7FE000h-7FEFFFh	
SA269	4 Kwords	7FF000h-7FFFFFh	



**Table I3. WS064J Sector Address Table (Sheet I of 6)**

Bank	Sector	Sector Size	(x16) Address Range
Bank D	SA0	4 Kwords	000000h-000FFFh
	SA1	4 Kwords	001000h-001FFFh
	SA2	4 Kwords	002000h-002FFFh
	SA3	4 Kwords	003000h-003FFFh
	SA4	4 Kwords	004000h-004FFFh
	SA5	4 Kwords	005000h-005FFFh
	SA6	4 Kwords	006000h-006FFFh
	SA7	4 Kwords	007000h-007FFFh
	SA8	32 Kwords	008000h-00FFFFFFh
	SA9	32 Kwords	010000h-017FFFh
	SA10	32 Kwords	018000h-01FFFFFFh
	SA11	32 Kwords	020000h-027FFFh
	SA12	32 Kwords	028000h-02FFFFFFh
	SA13	32 Kwords	030000h-037FFFh
	SA14	32 Kwords	038000h-03FFFFFFh
	SA15	32 Kwords	040000h-047FFFh
	SA16	32 Kwords	048000h-04FFFFFFh
	SA17	32 Kwords	050000h-057FFFh
	SA18	32 Kwords	058000h-05FFFFFFh
	SA19	32 Kwords	060000h-067FFFh
	SA20	32 Kwords	068000h-06FFFFFFh
	SA21	32 Kwords	070000h-077FFFh
SA22	32 Kwords	078000h-07FFFFFFh	

**Table I3. WS064J Sector Address Table (Sheet 2 of 6)**

Bank	Sector	Sector Size	(x16) Address Range
Bank C	SA23	32 Kwords	080000h-087FFFh
	SA24	32 Kwords	088000h-08FFFFh
	SA25	32 Kwords	090000h-097FFFh
	SA26	32 Kwords	098000h-09FFFFh
	SA27	32 Kwords	0A0000h-0A7FFFh
	SA28	32 Kwords	0A8000h-0AFFFFh
	SA29	32 Kwords	0B0000h-0B7FFFh
	SA30	32 Kwords	0B8000h-0BFFFFh
	SA31	32 Kwords	0C0000h-0C7FFFh
	SA32	32 Kwords	0C8000h-0CFFFFh
	SA33	32 Kwords	0D0000h-0D7FFFh
	SA34	32 Kwords	0D8000h-0DFFFFh
	SA35	32 Kwords	0E0000h-0E7FFFh
	SA36	32 Kwords	0E8000h-0EFFFFh
	SA37	32 Kwords	0F0000h-0F7FFFh
	SA38	32 Kwords	0F8000h-0FFFFFh
	SA39	32 Kwords	100000h-107FFFh
	SA40	32 Kwords	108000h-10FFFFh
	SA41	32 Kwords	110000h-117FFFh
	SA42	32 Kwords	118000h-11FFFFh
	SA43	32 Kwords	120000h-127FFFh
	SA44	32 Kwords	128000h-12FFFFh
	SA45	32 Kwords	130000h-137FFFh
	SA46	32 Kwords	138000h-13FFFFh

**Table I3. WS064J Sector Address Table (Sheet 3 of 6)**

Bank	Sector	Sector Size	(x16) Address Range
Bank C	SA47	32 Kwords	140000h-147FFFh
	SA48	32 Kwords	148000h-14FFFFh
	SA49	32 Kwords	150000h-157FFFh
	SA50	32 Kwords	158000h-15FFFFh
	SA51	32 Kwords	160000h-167FFFh
	SA52	32 Kwords	168000h-16FFFFh
	SA53	32 Kwords	170000h-177FFFh
	SA54	32 Kwords	178000h-17FFFFh
	SA55	32 Kwords	180000h-187FFFh
	SA56	32 Kwords	188000h-18FFFFh
	SA57	32 Kwords	190000h-197FFFh
	SA58	32 Kwords	198000h-19FFFFh
	SA59	32 Kwords	1A0000h-1A7FFFh
	SA60	32 Kwords	1A8000h-1AFFFFh
	SA61	32 Kwords	1B0000h-1B7FFFh
	SA62	32 Kwords	1B8000h-1BFFFFh
	SA63	32 Kwords	1C0000h-1C7FFFh
	SA64	32 Kwords	1C8000h-1CFFFFh
	SA65	32 Kwords	1D0000h-1D7FFFh
	SA66	32 Kwords	1D8000h-1DFFFFh
SA67	32 Kwords	1E0000h-1E7FFFh	
SA68	32 Kwords	1E8000h-1EFFFFh	
SA69	32 Kwords	1F0000h-1F7FFFh	
SA70	32 Kwords	1F8000h-1FFFFFh	

**Table I3. WS064J Sector Address Table (Sheet 4 of 6)**

Bank	Sector	Sector Size	(x16) Address Range
Bank B	SA71	32 Kwords	200000h-207FFFh
	SA72	32 Kwords	208000h-20FFFFh
	SA73	32 Kwords	210000h-217FFFh
	SA74	32 Kwords	218000h-21FFFFh
	SA75	32 Kwords	220000h-227FFFh
	SA76	32 Kwords	228000h-22FFFFh
	SA77	32 Kwords	230000h-237FFFh
	SA78	32 Kwords	238000h-23FFFFh
	SA79	32 Kwords	240000h-247FFFh
	SA80	32 Kwords	248000h-24FFFFh
	SA81	32 Kwords	250000h-257FFFh
	SA82	32 Kwords	258000h-25FFFFh
	SA83	32 Kwords	260000h-267FFFh
	SA84	32 Kwords	268000h-26FFFFh
	SA85	32 Kwords	270000h-277FFFh
	SA86	32 Kwords	278000h-27FFFFh
	SA87	32 Kwords	280000h-287FFFh
	SA88	32 Kwords	288000h-28FFFFh
	SA89	32 Kwords	290000h-297FFFh
	SA90	32 Kwords	298000h-29FFFFh
	SA91	32 Kwords	2A0000h-2A7FFFh
	SA92	32 Kwords	2A8000h-2AFFFFh
	SA93	32 Kwords	2B0000h-2B7FFFh
	SA94	32 Kwords	2B8000h-2BFFFFh

**Table I3. WS064J Sector Address Table (Sheet 5 of 6)**

Bank	Sector	Sector Size	(x16) Address Range
Bank B	SA95	32 Kwords	2C0000h-2C7FFFh
	SA96	32 Kwords	2C8000h-2CFFFFh
	SA97	32 Kwords	2D0000h-2D7FFFh
	SA98	32 Kwords	2D8000h-2DFFFFh
	SA99	32 Kwords	2E0000h-2E7FFFh
	SA100	32 Kwords	2E8000h-2EFFFFh
	SA101	32 Kwords	2F0000h-2F7FFFh
	SA102	32 Kwords	2F8000h-2FFFFFh
	SA103	32 Kwords	300000h-307FFFh
	SA104	32 Kwords	308000h-30FFFFh
	SA105	32 Kwords	310000h-317FFFh
	SA106	32 Kwords	318000h-31FFFFh
	SA107	32 Kwords	320000h-327FFFh
	SA108	32 Kwords	328000h-32FFFFh
	SA109	32 Kwords	330000h-337FFFh
	SA110	32 Kwords	338000h-33FFFFh
	SA111	32 Kwords	340000h-347FFFh
	SA112	32 Kwords	348000h-34FFFFh
SA113	32 Kwords	350000h-357FFFh	
SA114	32 Kwords	358000h-35FFFFh	
SA115	32 Kwords	360000h-367FFFh	
SA116	32 Kwords	368000h-36FFFFh	
SA117	32 Kwords	370000h-377FFFh	
SA118	32 Kwords	378000h-37FFFFh	

**Table I3. WS064J Sector Address Table (Sheet 6 of 6)**

Bank	Sector	Sector Size	(x16) Address Range
Bank A	SA119	32 Kwords	380000h-387FFFh
	SA120	32 Kwords	388000h-38FFFFh
	SA121	32 Kwords	390000h-397FFFh
	SA122	32 Kwords	398000h-39FFFFh
	SA123	32 Kwords	3A0000h-3A7FFFh
	SA124	32 Kwords	3A8000h-3AFFFFh
	SA125	32 Kwords	3B0000h-3B7FFFh
	SA126	32 Kwords	3B8000h-3BFFFFh
	SA127	32 Kwords	3C0000h-3C7FFFh
	SA128	32 Kwords	3C8000h-3CFFFFh
	SA129	32 Kwords	3D0000h-3D7FFFh
	SA130	32 Kwords	3D8000h-3DFFFFh
	SA131	32 Kwords	3E0000h-3E7FFFh
	SA132	32 Kwords	3E8000h-3EFFFFh
	SA133	32 Kwords	3F0000h-3F7FFFh
	SA134	4 Kwords	3F8000h-3F8FFFh
	SA135	4 Kwords	3F9000h-3F9FFFh
	SA136	4 Kwords	3FA000h-3FAFFFh
	SA137	4 Kwords	3FB000h-3FBFFFh
	SA138	4 Kwords	3FC000h-3FCFFFh
SA139	4 Kwords	3FD000h-3FDFFFh	
SA140	4 Kwords	3FE000h-3FEFFFh	
SA141	4 Kwords	3FF000h-3FFFFFh	

## Command Definitions

Writing specific address and data commands or sequences into the command register initiates device operations. [Table 18, "Command Definitions," on page 60](#) defines the valid register command sequences. Writing incorrect address and data values or writing them in the improper sequence may place the device in an unknown state. The system must write the reset command to return the device to reading array data. Refer to the AC Characteristics section for timing diagrams.

## Reading Array Data

The device is automatically set to reading array data after device power-up. No commands are required to retrieve data in asynchronous mode. Each bank is ready to read array data after completing an Embedded Program or Embedded Erase algorithm.

After the device accepts an Erase Suspend command, the corresponding bank enters the erase-suspend-read mode, after which the system can read data from any non-erase-suspended sector within the same bank. After completing a programming operation in the Erase Suspend mode, the system may once again read array data from any non-erase-suspended sector within the same bank. See the "Erase Suspend/Erase Resume Commands" section on page 55 for more information.

The system must issue the reset command to return a bank to the read (or erase-suspend-read) mode if DQ5 goes high during an active program or erase operation, or if the bank is in the autoselect mode. See the "Reset Command" section on page 51 for more information.

See also "Requirements for Asynchronous ReadOperation (Non-Burst)" section on page 14 and "Requirements for Synchronous (Burst) Read Operation" section on page 14 for more information. The Asynchronous Read and Synchronous/Burst Read tables provide the read parameters, and [Figure 15, "CLK Synchronous Burst Mode Read \(rising active CLK\)," on page 74](#), [Figure 17, "Synchronous Burst Mode Read," on page 75](#), and [Figure 20, "Asynchronous Mode Read with Latched Addresses," on page 77](#) show the timings.

### Set Configuration Register Command Sequence

The device uses a configuration register to set the various burst parameters: number of wait states, burst read mode, active clock edge, RDY configuration, and synchronous mode active. The configuration register must be set before the device will enter burst mode.

The configuration register is loaded with a three-cycle command sequence. The first two cycles are standard unlock sequences. On the third cycle, the data should be C0h, address bits A11–A0 should be 555h, and address bits A19–A12 set the code to be latched. The device will power up or after a hardware reset with the default setting, which is in asynchronous mode. The register must be set before the device can enter synchronous mode. The configuration register can not be changed during device operations (program, erase, or sector lock).

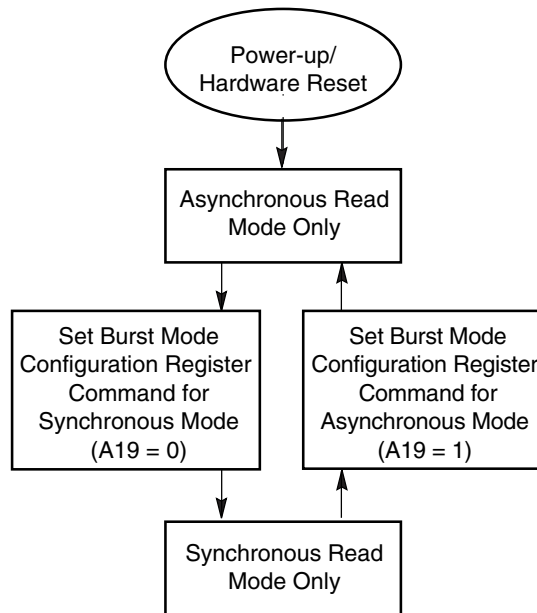

**Figure 4. Synchronous/Asynchronous State Diagram**

**Read Mode Setting**

On power-up or hardware reset, the device is set to be in asynchronous read mode. This setting allows the system to enable or disable burst mode during system operations. Address A19 determines this setting: "1" for asynchronous mode, "0" for synchronous mode.

**Programmable Wait State Configuration**

The programmable wait state feature informs the device of the number of clock cycles that must elapse after AVD# is driven active before data will be available. This value is determined by the input frequency of the device. Address bits A14–A12 determine the setting (see [Table 14, "Programmable Wait State Settings," on page 49](#)).

The wait state command sequence instructs the device to set a particular number of clock cycles for the initial access in burst mode. The number of wait states that should be programmed into the device is directly related to the clock frequency.



**Table I4. Programmable Wait State Settings**

AI4	AI3	AI2	Total Initial Access Cycles
0	0	0	2
0	0	1	3
0	1	0	4
0	1	1	5
1	0	0	6
1	0	1	7 (default)
1	1	0	Reserved
1	1	1	Reserved

**Notes:**

1. Upon power-up or hardware reset, the default setting is seven wait states.
2. RDY will default to being active with data when the Wait State Setting is set to a total initial access cycle of 2.

It is recommended that the wait state command sequence be written, even if the default wait state value is desired, to ensure the device is set as expected. A hardware reset will set the wait state to the default setting.

**Standard wait-state Handshaking Option**

The host system must set the appropriate number of wait states in the flash device depending upon the clock frequency. The host system should set address bits A14–A12 to 010 for a clock frequency of 66/80 MHz for the system/device to execute at maximum speed.

Table 15 describes the recommended number of clock cycles (wait states) for various conditions.

**Table I5. Wait States for Standard wait-state Handshaking**

Burst Mode	Typical No. of Clock Cycles after AVD# Low	
	66 MHz	80 MHz
8-Word or 16-Word or Continuous	4	6 or 7
32-Word	5	7

**Notes:**

1. In the 8-, 16- and 32-word burst read modes, the address pointer does not cross 64-word boundaries (addresses which are multiples of 3Fh).
2. For WS128J model numbers 10 and 11, an additional clock cycle is required for boundary crossings while in Continuous read mode.

The host system must set the appropriate number of wait states in the flash device depending upon the clock frequency. Note that the host system must set again the number of wait state when the host system change the clock frequency. For example, the host system must set from 6 or 7 wait state to less than 5 wait states when the host system change the clock frequency from 80MHz to less than 80MHz. The autoselect function allows the host system to determine whether the flash device is enabled for handshaking. See the "Autoselect Command Sequence" section on page 51 for more information.

### Read Mode Configuration

The device supports four different read modes: continuous mode, and 8, 16, and 32 word linear wrap around modes. A continuous sequence begins at the starting address and advances the address pointer until the burst operation is complete. If the highest address in the device is reached during the continuous burst read mode, the address pointer wraps around to the lowest address.

For example, an eight-word linear read with wrap around begins on the starting address written to the device and then advances to the next 8 word boundary. The address pointer then returns to the 1st word after the previous eight word boundary, wrapping through the starting location. The sixteen- and thirty-two linear wrap around modes operate in a fashion similar to the eight-word mode.

Table 16 shows the address bits and settings for the four read modes.

**Table 16. Read Mode Settings**

Burst Modes	Address Bits	
	A16	A15
Continuous	0	0
8-word linear wrap around	0	1
16-word linear wrap around	1	0
32-word linear wrap around	1	1

**Note:** Upon power-up or hardware reset the default setting is continuous.

### Burst Active Clock Edge Configuration

By default, the device will deliver data on the rising edge of the clock after the initial synchronous access time. Subsequent outputs will also be on the following rising edges, barring any delays. The device can be set so that the falling clock edge is active for all synchronous accesses. Address bit A17 determines this setting; "1" for rising active, "0" for falling active.

### RDY Configuration

By default, the device is set so that the RDY pin will output  $V_{OH}$  whenever there is valid data on the outputs. The device can be set so that RDY goes active one data cycle before active data. Address bit A18 determines this setting; "1" for RDY active with data, "0" for RDY active one clock cycle before valid data. Only the combination of wait state 2 and RDY active one clock cycle before data is not supported. In asynchronous mode, RDY is an open-drain output.

### Configuration Register

Table 17 shows the address bits that determine the configuration register settings for various device functions.

Table 17. Configuration Register

Address Bit	Function	Settings (Binary)
A19	Set Device Read Mode	0 = Synchronous Read (Burst Mode) Enabled 1 = Asynchronous Mode (default)
A18	RDY	0 = RDY active one clock cycle before data 1 = RDY active with data (default)
A17	Clock	0 = Burst starts and data is output on the falling edge of CLK 1 = Burst starts and data is output on the rising edge of CLK (default)
A16	Read Mode	Synchronous Mode 00 = Continuous (default) 01 = 8-word linear with wrap around 10 = 16-word linear with wrap around 11 = 32-word linear with wrap around
A15		
A14	Programmable Wait State	000 = Data is valid on the 2nd active CLK edge after AVD# transition to $V_{IH}$ 001 = Data is valid on the 3rd active CLK edge after AVD# transition to $V_{IH}$ 010 = Data is valid on the 4th active CLK edge after AVD# transition to $V_{IH}$ 011 = Data is valid on the 5th active CLK edge after AVD# transition to $V_{IH}$ 100 = Data is valid on the 6th active CLK edge after AVD# transition to $V_{IH}$ 101 = Data is valid on the 7th active CLK edge after AVD# transition to $V_{IH}$ (default) 110 = Reserved 111 = Reserved
A13		
A12		

**Note:** Device is in the default state upon power-up or hardware reset.

## Reset Command

Writing the reset command resets the banks to the read or erase-suspend-read mode. Address bits are don't cares for this command.

The reset command may be written between the sequence cycles in an erase command sequence before erasing begins. This resets the bank to which the system was writing to the read mode. Once erasure begins, however, the device ignores reset commands until the operation is complete.

The reset command may be written between the sequence cycles in a program command sequence before programming begins (prior to the third cycle). This resets the bank to which the system was writing to the read mode. If the program command sequence is written to a bank that is in the Erase Suspend mode, writing the reset command returns that bank to the erase-suspend-read mode. Once programming begins, however, the device ignores reset commands until the operation is complete.

The reset command may be written between the sequence cycles in an autoselect command sequence. Once in the autoselect mode, the reset command must be written to return to the read mode. If a bank entered the autoselect mode while in the Erase Suspend mode, writing the reset command returns that bank to the erase-suspend-read mode.

If DQ5 goes high during a program or erase operation, writing the reset command returns the banks to the read mode (or erase-suspend-read mode if that bank was in Erase Suspend).

## Autoselect Command Sequence

The autoselect command sequence allows the host system to access the manufacturer and device codes, and determine whether or not a sector is protected. [Table 18, "Command Definitions," on page 60](#) shows the address and data requirements. The autoselect command sequence may be

written to an address within a bank that is either in the read or erase-suspend-read mode. The autoselect command may not be written while the device is actively programming or erasing in the other bank.

The autoselect command sequence is initiated by first writing two unlock cycles. This is followed by a third write cycle that contains the bank address and the autoselect command. The bank then enters the autoselect mode. No subsequent data will be made available if the autoselect data is read in synchronous mode. The system may read at any address within the same bank any number of times without initiating another autoselect command sequence. Read commands to other banks will return data from the array. The following table describes the address requirements for the various autoselect functions, and the resulting data. BA represents the bank address, and SA represents the sector address. The device ID is read in three cycles.

Description	Address	Read Data
Manufacturer ID	(BA) + 00h	0001h
Device ID, Word 1	(BA) + 01h	227Eh
Device ID, Word 2	(BA) + 0Eh	2218h (WS128J) 221Eh (WS064J)
Device ID, Word 3	(BA) + 0Fh	2200h (WS128J) 2201h (WS064J)
Sector Protection Verification	(SA) + 02h	0001 (locked), 0000 (unlocked)
Indicator Bits	(BA) + 03h	DQ15 - DQ8 = 0 DQ7 - Factory Lock Bit 1 = Locked, 0 = Not Locked DQ6 - Customer Lock Bit 1 = Locked, 0 = Not Locked DQ5 - Handshake Bit 1 = Reserved, 0 = Standard Handshake DQ4 & DQ3 - Boot Code 00 = Dual Boot Sector, 01 = Top Boot Sector, 10 = Bottom Boot Sector DQ2 - DQ0 = 001

The system must write the reset command to return to the read mode (or erase-suspend-read mode if the bank was previously in Erase Suspend).

### Enter Secured Silicon Sector/Exit Secured Silicon Sector Command Sequence

The Secured Silicon Sector region provides a secured data area containing a random, eight word electronic serial number (ESN). The system can access the Secured Silicon Sector region by issuing the three-cycle Enter Secured Silicon Sector command sequence. The device continues to access the Secured Silicon Sector region until the system issues the four-cycle Exit Secured Silicon Sector command sequence. The Exit Secured Silicon Sector command sequence returns the device to normal operation. The Secured Silicon Sector is not accessible when the device is executing an Embedded Program or embedded Erase algorithm. [Table 18, "Command Definitions," on page 60](#) shows the address and data requirements for both command sequences.

The following commands are not allowed when the Secured Silicon is accessible.

- CFI
- Unlock Bypass Entry
- Unlock Bypass Program
- Unlock Bypass Reset
- Erase Suspend/Resume
- Chip Erase

## Program Command Sequence

Programming is a four-bus-cycle operation. The program command sequence is initiated by writing two unlock write cycles, followed by the program set-up command. The program address and data are written next, which in turn initiate the Embedded Program algorithm. The system is not required to provide further controls or timings. The device automatically provides internally generated program pulses and verifies the programmed cell margin. [Table 18, "Command Definitions," on page 60](#) shows the address and data requirements for the program command sequence.

When the Embedded Program algorithm is complete, that bank then returns to the read mode and addresses are no longer latched. The system can determine the status of the program operation by monitoring DQ7 or DQ6/DQ2. Refer to the "Write Operation Status" section on page 62 for information on these status bits.

Any commands written to the device during the Embedded Program Algorithm are ignored. Note that a hardware reset immediately terminates the program operation. The program command sequence should be reinitiated once that bank has returned to the read mode, to ensure data integrity.

Programming is allowed in any sequence and across sector boundaries. A bit cannot be programmed from "0" back to a "1." Attempting to do so may cause that bank to set DQ5 = 1, or cause the DQ7 and DQ6 status bit to indicate the operation was successful. However, a succeeding read will show that the data is still "0." Only erase operations can convert a "0" to a "1."

## Unlock Bypass Command Sequence

The unlock bypass feature allows the system to primarily program to a array faster than using the standard program command sequence. The unlock bypass command sequence is initiated by first writing two unlock cycles. This is followed by a third write cycle containing the unlock bypass command, 20h. The device then enters the unlock bypass mode. A two-cycle unlock bypass program command sequence is all that is required to program in this mode. The first cycle in this sequence contains the unlock bypass program command, A0h; the second cycle contains the program address and data. Additional data is programmed in the same manner. This mode dispenses with the initial two unlock cycles required in the standard program command sequence, resulting in faster total programming time. The host system may also initiate the chip erase and sector erase sequences in the unlock bypass mode. The erase command sequences are four cycles in length instead of six cycles. [Table 18, "Command Definitions," on page 60](#) shows the requirements for the unlock bypass command sequences.

During the unlock bypass mode, only the Read, Unlock Bypass Program, Unlock Bypass Sector Erase, Unlock Bypass Chip Erase, and Unlock Bypass Reset commands are valid. To exit the unlock bypass mode, the system must issue the two-cycle unlock bypass reset command sequence. The first cycle must contain the bank address and the data 90h. The second cycle need only contain the data 00h. The array then returns to the read mode.

The device offers accelerated program operations through the ACC input. When the system asserts  $V_{HH}$  on this input, the device automatically enters the Unlock Bypass mode. The system may then write the two-cycle Unlock Bypass program command sequence. The device uses the higher voltage on the ACC input to accelerate the operation.

Figure 5, "Program Operation," on page 54 illustrates the algorithm for the program operation. Refer to the Erase/Program Operations table in the AC Characteristics section for parameters, and Figure 23, "Asynchronous Program Operation Timings: AVD# Latched Addresses," on page 81 and Figure 25, "Synchronous Program Operation Timings: WE# Latched Addresses," on page 83 for timing diagrams.

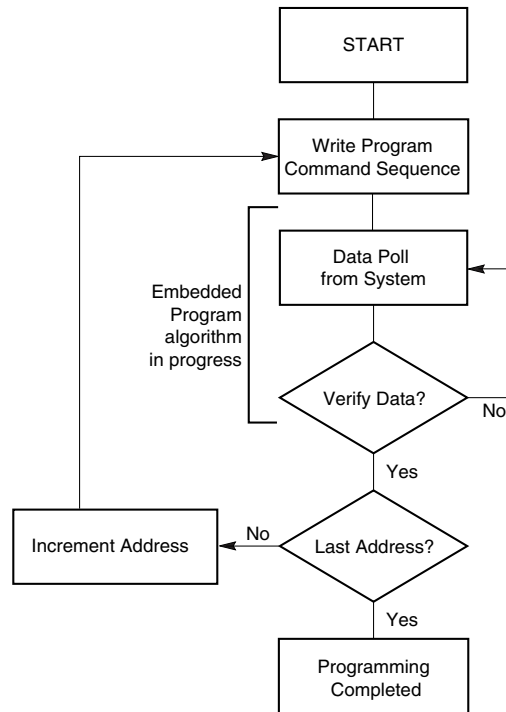

**Note:** See Table 18 for program command sequence.

**Figure 5. Program Operation**

### Chip Erase Command Sequence

Chip erase is a six bus cycle operation. The chip erase command sequence is initiated by writing two unlock cycles, followed by a set-up command. Two additional unlock write cycles are then followed by the chip erase command, which in turn invokes the Embedded Erase algorithm. The device does not require the system to preprogram prior to erase. The Embedded Erase algorithm automatically preprograms and verifies the entire memory for an all zero data pattern prior to electrical erase. The system is not required to provide any controls or timings during these operations. Table 18, "Command Definitions," on page 60 shows the address and data requirements for the chip erase command sequence.

When the Embedded Erase algorithm is complete, that bank returns to the read mode and addresses are no longer latched. The system can determine the status of the erase operation by using DQ7 or DQ6/DQ2. Refer to the "Write Operation Status" section on page 62 for information on these status bits.

Any commands written during the chip erase operation are ignored. However, note that a **hardware reset** immediately terminates the erase operation. If that occurs, the chip erase command sequence should be reinitiated once that bank has returned to reading array data, to ensure data integrity.

The host system may also initiate the chip erase command sequence while the device is in the unlock bypass mode. The command sequence is two cycles in length instead of six cycles. See [Table 18, "Command Definitions," on page 60](#) for details on the unlock bypass command sequences.

[Figure 6, "Erase Operation," on page 56](#) illustrates the algorithm for the erase operation. Refer to the Erase/Program Operations table in the AC Characteristics section for parameters and timing diagrams.

## Sector Erase Command Sequence

Sector erase is a six bus cycle operation. The sector erase command sequence is initiated by writing two unlock cycles, followed by a set-up command. Two additional unlock cycles are written, and are then followed by the address of the sector to be erased, and the sector erase command. [Table 18, "Command Definitions," on page 60](#) shows the address and data requirements for the sector erase command sequence.

The device does not require the system to preprogram prior to erase. The Embedded Erase algorithm automatically programs and verifies the entire memory for an all zero data pattern prior to electrical erase. The system is not required to provide any controls or timings during these operations.

After the command sequence is written, a sector erase time-out of no less than 50  $\mu$ s occurs. During the time-out period, additional sector addresses and sector erase commands may be written. Loading the sector erase buffer may be done in any sequence, and the number of sectors may be from one sector to all sectors. The time between these additional cycles must be less than 50  $\mu$ s, otherwise erasure may begin. Any sector erase address and command following the exceeded time-out may or may not be accepted. It is recommended that processor interrupts be disabled during this time to ensure all commands are accepted. The interrupts can be re-enabled after the last Sector Erase command is written. If any command other than 30h, B0h, F0h is input during the time-out period, the normal operation will not be guaranteed.

The system can monitor DQ3 to determine if the sector erase timer has timed out (See "DQ3: Sector Erase Timer" section on page 67.) The time-out begins from the rising edge of the final WE# pulse in the command sequence.

When the Embedded Erase algorithm is complete, the bank returns to reading array data and addresses are no longer latched. Note that while the Embedded Erase operation is in progress, the system can read data from the non-erasing bank. The system can determine the status of the erase operation by reading DQ7 or DQ6/DQ2 in the erasing bank. Refer to the "Write Operation Status" section on page 62 for information on these status bits.

Once the sector erase operation has begun, only the Erase Suspend command is valid. All other commands are ignored. However, note that a hardware reset immediately terminates the erase operation. If that occurs, the sector erase command sequence should be reinitiated once that bank has returned to reading array data, to ensure data integrity.

The host system may also initiate the sector erase command sequence while the device is in the unlock bypass mode. The command sequence is four cycles in length instead of six cycles.

[Figure 6, "Erase Operation," on page 56](#) illustrates the algorithm for the erase operation. Refer to the Erase/Program Operations table in the [AC Characteristics](#) on page 72 for parameters and timing diagrams.

## Erase Suspend/Erase Resume Commands

The Erase Suspend command, B0h, allows the system to interrupt a sector erase operation and then read data from, or program data to, any sector not selected for erasure. The bank address is required when writing this command. This command is valid only during the sector erase op-

eration, including the minimum 50  $\mu$ s time-out period during the sector erase command sequence. The Erase Suspend command is ignored if written during the chip erase operation or Embedded Program algorithm.

When the Erase Suspend command is written during the sector erase operation, the device requires a maximum of 35  $\mu$ s to suspend the erase operation. However, when the Erase Suspend command is written during the sector erase time-out, the device immediately terminates the time-out period and suspends the erase operation.

After the erase operation has been suspended, the bank enters the erase-suspend-read mode. The system can read data from or program data to any sector not selected for erasure. (The device "erase suspends" all sectors selected for erasure.) Reading at any address within erase-suspended sectors produces status information on DQ7–DQ0. The system can use DQ7, or DQ6 and DQ2 together, to determine if a sector is actively erasing or is erase-suspended. Refer to the [Figure , "Write Operation Status," on page 62](#) for information on these status bits.

After an erase-suspended program operation is complete, the bank returns to the erase-suspend-read mode. The system can determine the status of the program operation using the DQ7 or DQ6 status bits, just as in the standard program operation. Refer to the "Write Operation Status" section on page 62 for more information.

In the erase-suspend-read mode, the system can also issue the autoselect command sequence. Refer to the "Autoselect Mode" section on page 17 and "Autoselect Command Sequence" section on page 51 for details.

To resume the sector erase operation, the system must write the Erase Resume command. The bank address of the erase-suspended bank is required when writing this command. Further writes of the Resume command are ignored. Another Erase Suspend command can be written after the chip has resumed erasing.

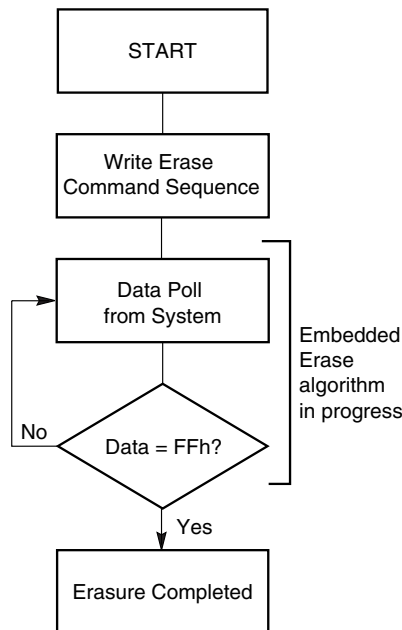

**Notes:**

1. See [Table 18](#) for erase command sequence.
2. See the section on DQ3 for information on the sector erase timer

**Figure 6. Erase Operation**



## Password Program Command

The Password Program Command permits programming the password that is used as part of the hardware protection scheme. The actual password is 64-bits long. 4 Password Program commands are required to program the password. The user must enter the unlock cycle, password program command (38h) and the program address/data for each portion of the password when programming. There are no provisions for entering the 2-cycle unlock cycle, the password program command, and all the password data. There is no special addressing order required for programming the password. Also, when the password is undergoing programming, Simultaneous Operation is disabled. Read operations to any memory location will return the programming status except DQ7. Once programming is complete, the user must issue a Read/Reset command to the device to normal operation. Once the Password is written and verified, the Password Mode Locking Bit must be set in order to prevent verification. The Password Program Command is only capable of programming "0"s. Programming a "1" after a cell is programmed as a "0" results in a time-out by the Embedded Program Algorithm™ with the cell remaining as a "0". The password is all F's when shipped from the factory. All 64-bit password combinations are valid as a password.

## Password Verify Command

The Password Verify Command is used to verify the Password. The Password is verifiable only when the Password Mode Locking Bit is not programmed. If the Password Mode Locking Bit is programmed and the user attempts to verify the Password, the device will always drive all F's onto the DQ data bus.

Also, the device will not operate in Simultaneous Operation when the Password Verify command is executed. Only the password is returned regardless of the bank address. The lower two address bits (A1–A0) are valid during the Password Verify. Writing the Secured Silicon Exit command returns the device back to normal operation.

## Password Protection Mode Locking Bit Program Command

The Password Protection Mode Locking Bit Program Command programs the Password Protection Mode Locking Bit, which prevents further verifies or updates to the password. Once programmed, the Password Protection Mode Locking Bit cannot be erased and the Persistent Protection Mode Locking Bit program circuitry is disabled, thereby forcing the device to remain in the Password Protection Mode. After issuing "PL/68h" at the fourth bus cycle, the device requires a time out period of approximately 150  $\mu$ s for programming the Password Protection Mode Locking Bit. Then by writing "PL/48h" at the fifth bus cycle, the device outputs verify data at DQ0. If DQ0 = 1, then the Password Protection Mode Locking Bit is programmed. If not, the system must repeat this program sequence from the fourth cycle of "PL/68h". Exiting the Password Protection Mode Locking Bit Program command is accomplished by writing the Secured Silicon Sector Exit command or Read/Reset command.

## Persistent Sector Protection Mode Locking Bit Program Command

The Persistent Sector Protection Mode Locking Bit Program Command programs the Persistent Sector Protection Mode Locking Bit, which prevents the Password Mode Locking Bit from ever being programmed. By disabling the program circuitry of the Password Mode Locking Bit, the device is forced to remain in the Persistent Sector Protection mode of operation, once this bit is set. After issuing "SL/68h" at the fourth bus cycle, the device requires a time out period of approximately 150  $\mu$ s for programming the Persistent Protection Mode Locking Bit. Then by writing "SMPL/48h" at the fifth bus cycle, the device outputs verify data at DQ0. If DQ0 = 1, then the Persistent Protection Mode Locking Bit is programmed. If not, the system must repeat this program sequence from the fourth cycle of "PL/68h". Exiting the Persistent Protection Mode Locking Bit Program command is accomplished by writing the Secured Silicon Sector Exit command or Read/Reset command.

## Secured Silicon Sector Protection Bit Program Command

To protect the Secured Silicon Sector, write the Secured Silicon Sector Protect command sequence while in the Secured Silicon Sector mode. After issuing "OW/48h" at the fourth bus cycle, the device requires a time out period of approximately 150  $\mu$ s to protect the Secured Silicon Sector. Then, by writing "OPBP/48" at the fifth bus cycle, the device outputs verify data at DQ0. If DQ0 = 1, then the Secured Silicon Sector is protected. If not, then the system must repeat this program sequence from the fourth cycle of "OPBP/48h". Exiting the Secured Silicon Sector Protection Mode Locking Bit Program command is accomplished by writing the Secured Silicon Sector Exit command or Read/Reset command.

## PPB Lock Bit Set Command

The PPB Lock Bit Set command is used to set the PPB Lock bit if it is cleared either at reset or if the Password Unlock command was successfully executed. There is no PPB Lock Bit Clear command. Once the PPB Lock Bit is set, it cannot be cleared unless the device is taken through a power-on clear or the Password Unlock command is executed. Upon setting the PPB Lock Bit, the PPBs are latched. If the Password Mode Locking Bit is set, the PPB Lock Bit status is reflected as set, even after a power-on reset cycle. Exiting the PPB Lock Bit Set command is accomplished by writing the Secured Silicon Exit command, only while in the Persistent Sector Protection Mode.

## DPB Write/Erase/Status Command

The DPB Write command is used to set or clear a DPB for a given sector. The high order address bits (Amax–A11) are issued at the same time as the code 01h or 00h on DQ7–DQ0. All other DQ data bus pins are ignored during the data write cycle. The DPBs are modifiable at any time, regardless of the state of the PPB or PPB Lock Bit. If the PPB is set, the sector is protected regardless of the value of the DPB. If the PPB is cleared, setting the DPB to a 1 protects the sector from programs or erases. Since this is a volatile bit, removing power or resetting the device will clear the DPBs. The programming of the DPB for a given sector can be verified by writing a DPB Status command to the device. Exiting the DPB Write/Erase command is accomplished by writing the Read/Reset command. Exiting the DPB Status command is accomplished by writing the Secured Silicon Sector Exit command

## Password Unlock Command

The Password Unlock command is used to clear the PPB Lock Bit so that the PPBs can be unlocked for modification, thereby allowing the PPBs to become accessible for modification. The exact password must be entered in order for the unlocking function to occur. This command cannot be issued any faster than 2  $\mu$ s at a time to prevent a hacker from running through the all 64-bit combinations in an attempt to correctly match a password. If the command is issued before the 2  $\mu$ s execution window for each portion of the unlock, the command will be ignored.

The Password Unlock function is accomplished by writing Password Unlock command and data to the device to perform the clearing of the PPB Lock Bit. The password is 64 bits long, so the user must write the Password Unlock command 4 times. A1 and A0 are used for matching. Writing the Password Unlock command is not address order specific. The lower address A1–A0= 00, the next Password Unlock command is to A1–A0= 01, then to A1–A0= 10, and finally to A1–A0= 11.

Once the Password Unlock command is entered for all four words, the RDY pin goes LOW indicating that the device is busy. Also, reading the Bank D results in the DQ6 pin toggling, indicating that the Password Unlock function is in progress. Reading the other bank returns actual array data. Approximately 1 $\mu$ s is required for each portion of the unlock. Once the first portion of the password unlock completes (RDY is not driven and DQ6 does not toggle when read), the Password Unlock command is issued again, only this time with the next part of the password. Four Password Unlock commands are required to successfully clear the PPB Lock Bit. As with the first Password Unlock command, the RDY signal goes LOW and reading the device results in the DQ6 pin toggling on successive read operations until complete. It is the responsibility of the microprocessor to keep

track of the number of Password Unlock commands, the order, and when to read the PPB Lock bit to confirm successful password unlock. In order to relock the device into the Password Mode, the PPB Lock Bit Set command can be re-issued. Exiting the Password Unlock command is accomplished by writing the Secured Silicon Sector Exit command.

### PPB Program Command

The PPB Program command is used to program, or set, a given PPB. Each PPB is individually programmed (but is bulk erased with the other PPBs). The specific sector address (Amax–A12) are written at the same time as the program command 60h with A6 = 0. If the PPB Lock Bit is set and the corresponding PPB is set for the sector, the PPB Program command will not execute and the command will time-out without programming the PPB.

After programming a PPB, two additional cycles are needed to determine whether the PPB has been programmed with margin. After 4th cycle, the device requires approximately 150  $\mu$ s time out period for programming the PPB. And then after 5th cycle, the device outputs verify data at DQ0.

The PPB Program command does not follow the Embedded Program algorithm. Writing the Secured Silicon Sector Exit command or Read/Reset command return the device back to normal operation.

### All PPB Erase Command

The All PPB Erase command is used to erase all PPBs in bulk. There is no means for individually erasing a specific PPB. Unlike the PPB program, no specific sector address is required. However, when the PPB erase command is written (60h) and A6 = 1, all Sector PPBs are erased in parallel. If the PPB Lock Bit is set the ALL PPB Erase command will not execute and the command will time-out without erasing the PPBs.

After erasing the PPBs, two additional cycles are needed to determine whether the PPB has been erased with margin. After 4th cycle, the device requires approximately 1.5 ms time out period for erasing the PPB. And then after 5th cycle, the device outputs verify data at DQ0.

It is the responsibility of the user to preprogram all PPBs prior to issuing the All PPB Erase command. If the user attempts to erase a cleared PPB, over-erasure may occur making it difficult to program the PPB at a later time. Also note that the total number of PPB program/erase cycles is limited to 100 cycles. Cycling the PPBs beyond 100 cycles is not guaranteed. Writing the Secured Silicon Sector Exit command or Read/Reset command return the device back to normal operation.

### PPB Status Command

The programming of the PPB for a given sector can be verified by writing a PPB status verify command to the device. Writing the Secured Silicon Sector Exit command or Read/Reset command return the device back to normal operation.

### PPB Lock Bit Status Command

The programming of the PPB Lock Bit for a given sector can be verified by writing a PPB Lock Bit status verify command to the device. Writing the Secured Silicon Sector Exit command or Read/Reset command return the device back to normal operation.

## Command Definitions

Table 18. Command Definitions

Command Sequence (Note 1)		Cycles	Bus Cycles (Notes 1-6)													
			First		Second		Third		Fourth		Fifth		Sixth		Seventh	
			Addr	Data	Addr	Data	Addr	Data	Addr	Data	Addr	Data	Addr	Data	Addr	Data
Asynchronous Read (Note 7)		1	RA	RD												
Reset (Note 8)		1	XXX	F0												
Autoselect (Note 9)	Manufacturer ID	4	555	AA	2AA	55	(BA) 555	90	(BA) X00	0001						
	Device ID (Note 10)	6	555	AA	2AA	55	(BA) 555	90	(BA) X01	227E	(BA)X0E (Note 10)	(BA) X0F (Note 10)				
	Sector Lock Verify (Note 11)	4	555	AA	2AA	55	(SA) 555	90	(SA) X02	0000/0001						
	Indicator Bits	4	555	AA	2AA	55	(BA) 555	90	(BA) X03	(Note 12)						
Program		4	555	AA	2AA	55	555	A0	PA	Data						
Chip Erase		6	555	AA	2AA	55	555	80	555	AA	2AA	55	555	10		
Sector Erase		6	555	AA	2AA	55	555	80	555	AA	2AA	55	SA	30		
Erase Suspend (Note 15)		1	BA	B0												
Erase Resume (Note 16)		1	BA	30												
Set Configuration Register (Note 17)		3	555	AA	2AA	55	(CR) 555	C0								
CFI Query (Note 18)		1	55	98												
Unlock Bypass Mode	Unlock Bypass Entry	3	555	AA	2AA	55	555	20								
	Unlock Bypass Program (Notes 13, 14)	2	XX	A0	PA	PD										
	Unlock Bypass Sector Erase (Notes 13, 14)	2	XX	80	SA	30										
	Unlock Bypass Erase (Notes 13, 14)	2	XX	80	XXX	10										
	Unlock Bypass Reset (Notes 13, 14)	2	XX	90	XXX	00										
<b>Sector Protection Command Definitions</b>																
Secured Silicon Sector	Secured Silicon Sector Entry	3	555	AA	2AA	55	555	88								
	Secured Silicon Sector Exit	4	555	AA	2AA	55	555	90	XX	00						
	Secured Silicon Protection Bit Program (Notes 19, 21)	6	555	AA	2AA	55	555	60	OW	68	OW	48	OW	RD (0)		
Password Protection	Password Program (Notes 23)	4	555	AA	2AA	55	555	38	XX0	PD0						
									XX1	PD1						
									XX2	PD2						
									XX3	PD3						
	Password Verify	4	555	AA	2AA	55	555	C8	XX0	PD0						
									XX1	PD1						
									XX2	PD2						
									XX3	PD3						
	Password Unlock (Note 23)	7	555	AA	2AA	55	555	28	XX0	PD0	XX1	PD1	XX2	PD2	XX3	PD3

Command Sequence (Note 1)		Cycles	Bus Cycles (Notes 1-6)													
			First		Second		Third		Fourth		Fifth		Sixth		Seventh	
			Addr	Data	Addr	Data	Addr	Data	Addr	Data	Addr	Data	Addr	Data	Addr	Data
PPB Commands	PPB Program (Notes 21)	6	555	AA	2AA	55	555	60	SBA + WP	68	SBA + WP	48	XX	RD (0)		
	All PPB Erase (Notes 22, 24)	6	555	AA	2AA	55	555	60	WPE	60	SBA WPE	40	XX	RD (0)		
	PPB Status (Note 25)	4	555	AA	2AA	55	SBA 555	90	SBA +WP	RD (0)						
PPB Lock Bit	PPB Lock Bit Set	3	555	AA	2AA	55	555	78								
	PPB Lock Bit Status	4	555	AA	2AA	55	(BA) 555	58	BA	RD (1)						
DPB	DPB Write	4	555	AA	2AA	55	555	48	SA	X1						
	DPB Erase	4	555	AA	2AA	55	555	48	SA	X0						
	DPB Status	4	555	AA	2AA	55	(BA) 555	58	SA	RD (0)						
Password Protection Mode Locking Bit Program (Notes 21)		6	555	AA	2AA	55	555	60	PL	68	PL	48	PL	RD (0)		
Persistent Protection Mode Locking Bit Program (Notes 21)		6	555	AA	2AA	55	555	60	SL	68	SL	48	SL	RD (0)		

**Legend:**

- X = Don't care
- RA = Address of the memory location to be read.
- RD = Data read from location RA during read operation.
- PA = Address of the memory location to be programmed. Addresses latch on the rising edge of the AVD# pulse or active edge of CLK which ever comes first.
- PD = Data to be programmed at location PA. Data latches on the rising edge of WE# or CE# pulse, whichever happens first.
- SA = Address of the sector to be verified (in autoselect mode) or erased. Address bits Amax-A12 uniquely select any sector.
- BA = Address of the bank (WS128J: A22, A21, A20, WS064J: A21, A20, A19) that is being switched to autoselect mode, is in bypass mode, or is being erased.
- SLA = Address of the sector to be locked. Set sector address (SA) and either A6 = 1 for unlocked or A6 = 0 for locked.
- SBA = sector address block to be protected.
- CR = Configuration Register address bits A19-A12.
- OW = Address (A7-A0) is (00011010).
- PD3-PD0 = Password Data. PD3-PD0 present four 16 bit combinations that represent the 64-bit Password
- PWA = Password Address. Address bits A1 and A0 are used to select each 16-bit portion of the 64-bit entity.
- PWD = Password Data.
- PL = Address (A7-A0) is (00001010)
- RD(0) = DQ0 protection indicator bit. If protected, DQ0 = 1, if unprotected, DQ0 = 0.
- RD(1) = DQ1 protection indicator bit. If protected, DQ1 = 1, if unprotected, DQ1 = 0.
- SL = Address (A7-A0) is (00010010)
- WD = Write Data. See "Configuration Register" definition for specific write data
- WP = Address (A7-A0) is (00000010)
- WPE = address(A7-A0) is (01000010)

**Notes:**

1. See Table 1 for description of bus operations.
2. All values are in hexadecimal.
3. Except for the following, all bus cycles are write cycle: read cycle, fourth through sixth cycles of the Autoselect commands, fourth cycle of the configuration register verify and password verify commands, and any cycle reading at RD(0) and RD(1).
4. Data bits DQ15-DQ8 are don't care in command sequences, except for RD, PD, WD, PWD, and PD3-PD0.
5. Unless otherwise noted, address bits Amax-A12 are don't cares.
6. Writing incorrect address and data values or writing them in the improper sequence may place the device in an unknown state. The system must write the reset command to return the device to reading array data.
7. No unlock or command cycles required when bank is reading array data.
8. The Reset command is required to return to reading array data (or to the erase-suspend-read mode if previously in Erase Suspend) when a bank is in the autoselect mode, or if DQ5 goes high (while the bank is providing status information) or performing sector lock/unlock.
9. The fourth cycle of the autoselect command sequence is a read cycle. The system must provide the bank address. See the Autoselect Command Sequence section for more information.
10. (BA)X0Fh = 2200h (WS128J), (BA)X0Eh = 2218h (WS128J), (BA)X0Fh = 221Eh (WS064J), (BA)X0Eh = 2201h (WS064J)
11. The data is 0000h for an unlocked sector and 0001h for a locked sector
12. DQ15 - DQ8 = 0, DQ7 - Factory Lock Bit (1 = Locked, 0 = Not Locked), DQ6 - Customer Lock Bit (1 = Locked, 0 = Not Locked), DQ5 = Handshake Bit (1 = Reserved, 0 = Standard Handshake), DQ4 & DQ3 - Boot Code (00= Dual Boot Sector, 01= Top Boot Sector, 10= Bottom Boot Sector, 11=No Boot Sector), DQ2 - DQ0 = 001
13. The Unlock Bypass command sequence is required prior to this command sequence.

14. The Unlock Bypass Reset command is required to return to reading array data.
15. The system may read and program in non-erasing sectors, or enter the autoselect mode, when in the Erase Suspend mode. The Erase Suspend command is valid only during a sector erase operation, and requires the bank address.
16. The Erase Resume command is valid only during the Erase Suspend mode, and requires the bank address.
17. See "Set Configuration Register Command Sequence" for details.
18. Command is valid when device is ready to read array data or when device is in autoselect mode.
19. Regardless of CLK and AVD# interaction or Control Register bit 15 setting, command mode verifies are always asynchronous read operations.
20. ACC must be at  $V_{HH}$  during the entire operation of this command
21. The fourth cycle programs the addressed locking bit. The fifth and sixth cycles are used to validate whether the bit has been fully programmed. If DQ0 (in the sixth cycle) reads 0, the program command must be issued and verified again.
22. The fourth cycle erases all PPBs. The fifth and sixth cycles are used to validate whether the bits have been fully erased. If DQ0 (in the sixth cycle) reads 1, the erase command must be issued and verified again.
23. The entire four bus-cycle sequence must be entered for each portion of the password.
24. Before issuing the erase command, all PPBs should be programmed in order to prevent over-erasure of PPBs.
25. In the fourth cycle, 01h indicates PPB set; 00h indicates PPB not set.

## Write Operation Status

The device provides several bits to determine the status of a program or erase operation: DQ2, DQ3, DQ5, DQ6, and DQ7. [Table 20, "Write Operation Status," on page 67](#) and the following subsections describe the function of these bits. DQ7 and DQ6 each offers a method for determining whether a program or erase operation is complete or in progress.

### DQ7: Data# Polling

The Data# Polling bit, DQ7, indicates to the host system whether an Embedded Program or Erase algorithm is in progress or completed, or whether a bank is in Erase Suspend. Data# Polling is valid after the rising edge of the final WE# pulse in the command sequence.

During the Embedded Program algorithm, the device outputs on DQ7 the complement of the datum programmed to DQ7. This DQ7 status also applies to programming during Erase Suspend. When the Embedded Program algorithm is complete, the device outputs the datum programmed to DQ7. The system must provide the program address to read valid status information on DQ7. If a program address falls within a protected sector, Data# Polling on DQ7 is active for approximately 1  $\mu$ s, then that bank returns to the read mode.

During the Embedded Erase algorithm, Data# Polling produces a "0" on DQ7. When the Embedded Erase algorithm is complete, or if the bank enters the Erase Suspend mode, Data# Polling produces a "1" on DQ7. The system must provide an address within any of the sectors selected for erasure to read valid status information on DQ7.

After an erase command sequence is written, if all sectors selected for erasing are protected, Data# Polling on DQ7 is active for approximately 100  $\mu$ s, then the bank returns to the read mode. If not all selected sectors are protected, the Embedded Erase algorithm erases the unprotected sectors, and ignores the selected sectors that are protected. However, if the system reads DQ7 at an address within a protected sector, the status may not be valid.

Just prior to the completion of an Embedded Program or Erase operation, DQ7 may change asynchronously with DQ6–DQ0 while Output Enable (OE#) is asserted low. That is, the device may change from providing status information to valid data on DQ7. Depending on when the system samples the DQ7 output, it may read the status or valid data. Even if the device has completed the program or erase operation and DQ7 has valid data, the data outputs on DQ6–DQ0 may be still invalid. Valid data on DQ7–DQ0 will appear on successive read cycles.

[Table 20, "Write Operation Status," on page 67](#) shows the outputs for Data# Polling on DQ7. [Figure 7, "Data# Polling Algorithm," on page 63](#) shows the Data# Polling algorithm. [Figure 29, "Data# Polling Timings \(During Embedded Algorithm\)," on page 86](#) in the AC Characteristics section shows the Data# Polling timing diagram.

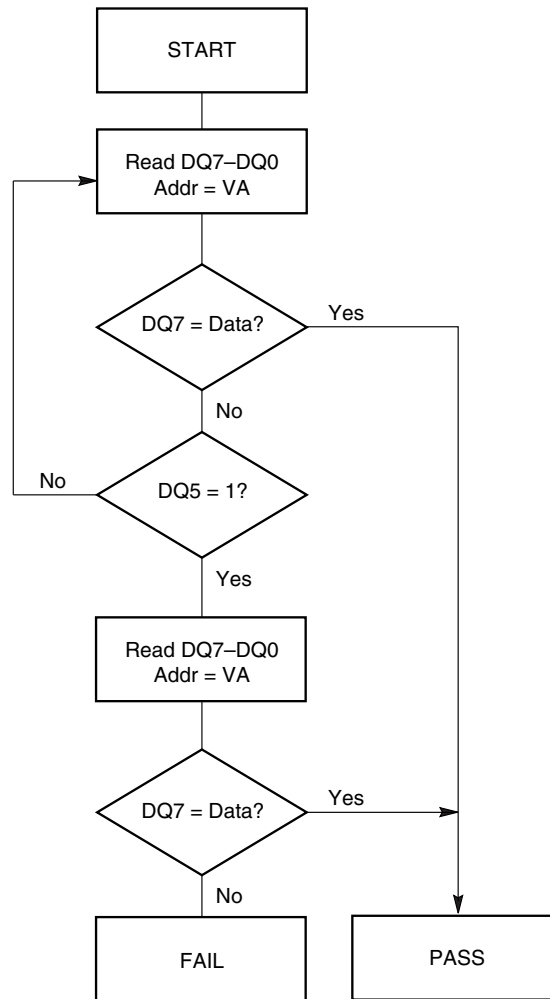
**Notes:**

1. *VA = Valid address for programming. During a sector erase operation, a valid address is any sector address within the sector being erased. During chip erase, a valid address is any non-protected sector address.*
2. *DQ7 should be rechecked even if DQ5 = "1" because DQ7 may change simultaneously with DQ5.*

**Figure 7. Data# Polling Algorithm****RDY: Ready**

The RDY is a dedicated output that, when the device is configured in the Synchronous mode, indicates (when at logic low) the system should wait 1 clock cycle before expecting the next word of data. The RDY pin is only controlled by CE#. Using the RDY Configuration Command Sequence, RDY can be set so that a logic low indicates the system should wait 2 clock cycles before expecting valid data.

The following conditions cause the RDY output to be low: during the initial access (in burst mode), and after the boundary that occurs every 64 words beginning with the 64th address, 3Fh.

When the device is configured in Asynchronous Mode, the RDY is an open-drain output pin which indicates whether an Embedded Algorithm is in progress or completed. The RDY status is valid after the rising edge of the final WE# pulse in the command sequence.



If the output is low (Busy), the device is actively erasing or programming. (This includes programming in the Erase Suspend mode.) If the output is in high impedance (Ready), the device is in the read mode, the standby mode, or in the erase-suspend-read mode. [Table 20, "Write Operation Status,"](#) on [page 67](#) shows the outputs for RDY.

### DQ6: Toggle Bit I

Toggle Bit I on DQ6 indicates whether an Embedded Program or Erase algorithm is in progress or complete, or whether the device has entered the Erase Suspend mode. Toggle Bit I may be read at any address in the same bank, and is valid after the rising edge of the final WE# pulse in the command sequence (prior to the program or erase operation), and during the sector erase timeout.

During an Embedded Program or Erase algorithm operation, successive read cycles to any address cause DQ6 to toggle. When the operation is complete, DQ6 stops toggling.

After an erase command sequence is written, if all sectors selected for erasing are protected, DQ6 toggles for approximately 100  $\mu$ s, then returns to reading array data. If not all selected sectors are protected, the Embedded Erase algorithm erases the unprotected sectors, and ignores the selected sectors that are protected.

The system can use DQ6 and DQ2 together to determine whether a sector is actively erasing or is erase-suspended. When the device is actively erasing (that is, the Embedded Erase algorithm is in progress), DQ6 toggles. When the device enters the Erase Suspend mode, DQ6 stops toggling. However, the system must also use DQ2 to determine which sectors are erasing or erase-suspended. Alternatively, the system can use DQ7 (see the subsection on DQ7: Data# Polling).

If a program address falls within a protected sector, DQ6 toggles for approximately 1 ms after the program command sequence is written, then returns to reading array data.

DQ6 also toggles during the erase-suspend-program mode, and stops toggling once the Embedded Program algorithm is complete.

See the following for additional information: [Figure 8, "Toggle Bit Algorithm,"](#) on [page 65](#), [DQ6: Toggle Bit I](#) on [page 64](#), [Figure 30, "Toggle Bit Timings \(During Embedded Algorithm\),"](#) on [page 87](#) (toggle bit timing diagram), and [Table 19, "DQ6 and DQ2 Indications,"](#) on [page 66](#).

Toggle Bit I on DQ6 requires either OE# or CE# to be deasserted and reasserted to show the change in state.



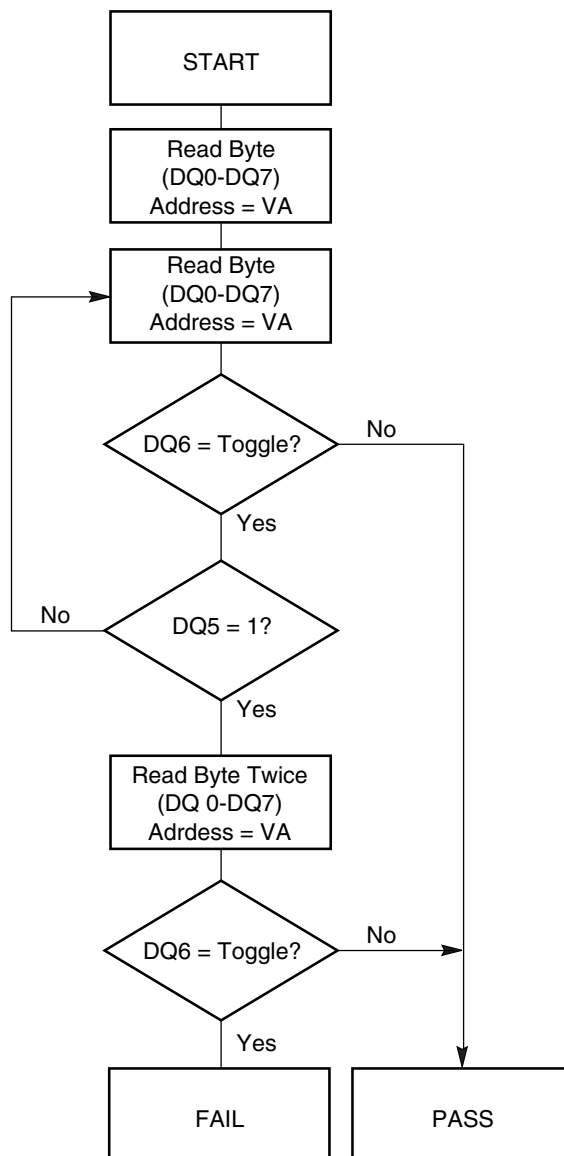

**Note:** The system should recheck the toggle bit even if  $DQ5 = "1"$  because the toggle bit may stop toggling as  $DQ5$  changes to "1." See the subsections on  $DQ6$  and  $DQ2$  for more information.

**Figure 8. Toggle Bit Algorithm**

## DQ2: Toggle Bit II

The "Toggle Bit II" on  $DQ2$ , when used with  $DQ6$ , indicates whether a particular sector is actively erasing (that is, the Embedded Erase algorithm is in progress), or whether that sector is erase-suspended. Toggle Bit II is valid after the rising edge of the final  $WE\#$  pulse in the command sequence.

$DQ2$  toggles when the system reads at addresses within those sectors that have been selected for erasure. But  $DQ2$  cannot distinguish whether the sector is actively erasing or is erase-suspended.  $DQ6$ , by comparison, indicates whether the device is actively erasing, or is in Erase

Suspend, but cannot distinguish which sectors are selected for erasure. Thus, both status bits are required for sector and mode information. Refer to [Table 19, "DQ6 and DQ2 Indications,"](#) on [page 66](#) to compare outputs for DQ2 and DQ6.

See the following for additional information: [Figure 8, "Toggle Bit Algorithm,"](#) on [page 65](#), See [DQ6: Toggle Bit I](#) on [page 64](#), [Figure 30, "Toggle Bit Timings \(During Embedded Algorithm\),"](#) on [page 87](#), and [Table 19, "DQ6 and DQ2 Indications,"](#) on [page 66](#).

**Table 19. DQ6 and DQ2 Indications**

If device is	and the system reads	then DQ6	and DQ2
programming,	at any address,	toggles,	does not toggle.
actively erasing,	at an address within a sector selected for erasure,	toggles,	also toggles.
	at an address within sectors <i>not</i> selected for erasure,	toggles,	does not toggle.
erase suspended,	at an address within a sector selected for erasure,	does not toggle,	toggles.
	at an address within sectors <i>not</i> selected for erasure,	returns array data,	returns array data. The system can read from any sector not selected for erasure.
programming in erase suspend	at any address,	toggles,	is not applicable.

### Reading Toggle Bits DQ6/DQ2

Refer to [Figure 8, "Toggle Bit Algorithm,"](#) on [page 65](#) for the following discussion. Whenever the system initially begins reading toggle bit status, it must read DQ7–DQ0 at least twice in a row to determine whether a toggle bit is toggling. Typically, the system would note and store the value of the toggle bit after the first read. After the second read, the system would compare the new value of the toggle bit with the first. If the toggle bit is not toggling, the device has completed the program or erase operation. The system can read array data on DQ7–DQ0 on the following read cycle.

However, if after the initial two read cycles, the system determines that the toggle bit is still toggling, the system also should note whether the value of DQ5 is high (see the section on DQ5). If it is, the system should then determine again whether the toggle bit is toggling, since the toggle bit may have stopped toggling just as DQ5 went high. If the toggle bit is no longer toggling, the device has successfully completed the program or erase operation. If it is still toggling, the device did not completed the operation successfully, and the system must write the reset command to return to reading array data.

The remaining scenario is that the system initially determines that the toggle bit is toggling and DQ5 has not gone high. The system may continue to monitor the toggle bit and DQ5 through successive read cycles, determining the status as described in the previous paragraph. Alternatively, it may choose to perform other system tasks. In this case, the system must start at the beginning of the algorithm when it returns to determine the status of the operation ([Figure 8, "Toggle Bit Algorithm,"](#) on [page 65](#)).

### DQ5: Exceeded Timing Limits

DQ5 indicates whether the program or erase time has exceeded a specified internal pulse count limit. Under these conditions DQ5 produces a "1," indicating that the program or erase cycle was not successfully completed.

The device may output a "1" on DQ5 if the system tries to program a "1" to a location that was previously programmed to "0." Only an erase operation can change a "0" back to a "1." Under this condition, the device halts the operation, and when the timing limit has been exceeded, DQ5 produces a "1."

Under both these conditions, the system must write the reset command to return to the read mode (or to the erase-suspend-read mode if a bank was previously in the erase-suspend-program mode).

### DQ3: Sector Erase Timer

After writing a sector erase command sequence, the system may read DQ3 to determine whether or not erasure has begun. (The sector erase timer does not apply to the chip erase command.) If additional sectors are selected for erasure, the entire time-out also applies after each additional sector erase command. When the time-out period is complete, DQ3 switches from a "0" to a "1." If the time between additional sector erase commands from the system can be assumed to be less than 50  $\mu$ s, the system need not monitor DQ3. See also [Sector Erase Command Sequence](#) on page 55.

After the sector erase command is written, the system should read the status of DQ7 (Data# Polling) or DQ6 (Toggle Bit I) to ensure that the device has accepted the command sequence, and then read DQ3. If DQ3 is "1," the Embedded Erase algorithm has begun; all further commands (except Erase Suspend) are ignored until the erase operation is complete. If DQ3 is "0," the device will accept additional sector erase commands. To ensure the command has been accepted, the system software should check the status of DQ3 prior to and following each subsequent sector erase command. If DQ3 is high on the second status check, the last command might not have been accepted.

[Table 20](#) shows the status of DQ3 relative to the other status bits.

**Table 20. Write Operation Status**

Status		DQ7 (Note 2)	DQ6	DQ5 (Note 1)	DQ3	DQ2 (Note 2)	RDY (Note 5)	
Standard Mode	Embedded Program Algorithm	DQ7#	Toggle	0	N/A	No toggle (Note 6)	0	
	Embedded Erase Algorithm	0	Toggle	0	1	Toggle	0	
Erase Suspend Mode	Erase-Suspend-Read (Note 4)	Erase Suspended Sector	1	No toggle (Note 6)	0	N/A	Toggle	High Impedance
		Non-Erase Suspended Sector	Data	Data	Data	Data	Data	High Impedance
	Erase-Suspend-Program	DQ7#	Toggle	0	N/A	N/A	0	

#### Notes:

1. DQ5 switches to '1' when an Embedded Program or Embedded Erase operation has exceeded the maximum timing limits. Refer to the section on DQ5 for more information.
2. DQ7 and DQ2 require a valid address when reading status information. Refer to the appropriate subsection for further details.
3. When reading write operation status bits, the system must always provide the bank address where the Embedded Algorithm is in progress. The device outputs array data if the system addresses a non-busy bank.
4. The system may read either asynchronously or synchronously (burst) while in erase suspend.
5. The RDY pin acts a dedicated output to indicate the status of an embedded erase or program operation is in progress. This is available in the Asynchronous mode only.
6. When the device is set to Asynchronous mode, these status flags should be read by CE# toggle.

## Absolute Maximum Ratings

Storage Temperature, Plastic Packages . . . . .	-65°C to +150°C
Ambient Temperature with Power Applied . . . . .	-65°C to +125°C
Voltage with Respect to Ground:	
All Inputs and I/Os except as noted below (Note 1). . . . .	-0.5 V to $V_{CC} + 0.5$ V
$V_{CC}$ (Note 1). . . . .	-0.5 V to +2.5 V
A9, RESET#, ACC (Note 1). . . . .	-0.5 V to +12.5 V
Output Short Circuit Current (Note 3) . . . . .	100 mA

**Notes:**

1. Minimum DC voltage on input or I/Os is -0.5 V. During voltage transitions, inputs or I/Os may undershoot  $V_{SS}$  to -2.0 V for periods of up to 20 ns. See Figure 9. Maximum DC voltage on input or I/Os is  $V_{CC} + 0.5$  V. During voltage transitions outputs may overshoot to  $V_{CC} + 2.0$  V for periods up to 20 ns. See Figure 10.
2. No more than one output may be shorted to ground at a time. Duration of the short circuit should not be greater than one second.
3. Stresses above those listed under "Absolute Maximum Ratings" may cause permanent damage to the device. This is a stress rating only; functional operation of the device at these or any other conditions above those indicated in the operational sections of this data sheet is not implied. Exposure of the device to absolute maximum rating conditions for extended periods may affect device reliability.

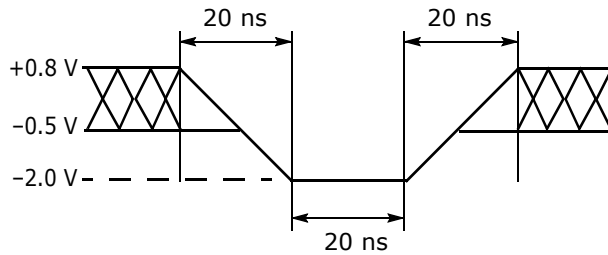

Figure 9. Maximum Negative Overshoot Waveform

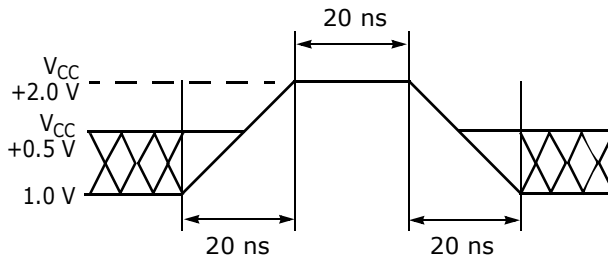

Figure 10. Maximum Positive Overshoot Waveform

## Operating Ranges

### Wireless (W) Devices

Ambient Temperature ( $T_A$ ) . . . . . -25°C to +85°C

### Industrial (I) Devices

Ambient Temperature ( $T_A$ ) . . . . . -40°C to +85°C

### Supply Voltages

$V_{CC}$  Supply Voltages . . . . . 1.65 V to 1.95 V (66MHz)  
 . . . . . 1.70 V to 1.95 V (80MHz)

**Note:** Operating ranges define those limits between which the functionality of the device is guaranteed.

## DC Characteristics

### CMOS Compatible

Parameter	Description	Test Conditions <b>Notes: 1</b>	Min	Typ	Max	Unit
$I_{LI}$	Input Load Current	$V_{IN} = V_{SS}$ to $V_{CC}$ , $V_{CC} = V_{CCmax}$			$\pm 1$	$\mu A$
$I_{LO}$	Output Leakage Current	$V_{OUT} = V_{SS}$ to $V_{CC}$ , $V_{CC} = V_{CCmax}$			$\pm 1$	$\mu A$
$I_{CCB}$	$V_{CC}$ Active burst Read Current	CE# = $V_{IL}$ , OE# = $V_{IH}$ , WE# = $V_{IH}$ , burst length = 8	66 MHz	15	30	mA
			80 MHz	18	36	mA
		CE# = $V_{IL}$ , OE# = $V_{IH}$ , WE# = $V_{IH}$ , burst length = 16	66 MHz	15	30	mA
			80 MHz	18	36	mA
		CE# = $V_{IL}$ , OE# = $V_{IH}$ , WE# = $V_{IH}$ , burst length = Continuous	66 MHz	15	30	mA
80 MHz	18	36	mA			
$I_{IO1}$	$V_{CC}$ Non-active Output	OE# = $V_{IH}$		0.2	10	$\mu A$
$I_{CC1}$	$V_{CC}$ Active Asynchronous Read Current (Note 2)	CE# = $V_{IL}$ , OE# = $V_{IH}$ , WE# = $V_{IH}$	10 MHz	20	30	mA
			5 MHz	12	16	mA
			1 MHz	3.5	5	mA
$I_{CC2}$	$V_{CC}$ Active Write Current (Note 3)	CE# = $V_{IL}$ , OE# = $V_{IH}$ , ACC = $V_{IH}$		15	40	mA
$I_{CC3}$	$V_{CC}$ Standby Current (Note 4)	CE# = RESET# = $V_{CC} \pm 0.2 V$		0.2	50	$\mu A$
$I_{CC4}$	$V_{CC}$ Reset Current	RESET# = $V_{IL}$ , CLK = $V_{IL}$		0.2	50	$\mu A$
$I_{CC5}$	$V_{CC}$ Active Current (Read While Write)	CE# = $V_{IL}$ , OE# = $V_{IH}$	66 MHz	22	54	mA
			80 MHz	25	60	mA
$I_{CC6}$	$V_{CC}$ Sleep Current	CE# = $V_{IL}$ , OE# = $V_{IH}$		0.2	50	$\mu A$
$I_{ACC}$	Accelerated Program Current (Note 5)	CE# = $V_{IL}$ , OE# = $V_{IH}$ , $V_{ACC} = 12.0 \pm 0.5 V$	$V_{ACC}$	7	15	mA
			$V_{CC}$	5	10	mA
$V_{IL}$	Input Low Voltage		-0.5		0.4	V
$V_{IH}$	Input High Voltage		$V_{CC} - 0.4$		$V_{CC} + 0.4$	
$V_{OL}$	Output Low Voltage	$I_{OL} = 100 \mu A$ , $V_{CC} = V_{CC min} = V_{IO}$			0.1	V
$V_{OH}$	Output High Voltage	$I_{OH} = -100 \mu A$ , $V_{CC} = V_{CC min}$	$V_{CC} - 0.1$			V
$V_{ID}$	Voltage for Autoselect and Temporary Sector Unprotect	$V_{CC} = 1.8 V$	11.5		12.5	V
$V_{HH}$	Voltage for Accelerated Program		11.5		12.5	V
$V_{LKO}$	Low $V_{CC}$ Lock-out Voltage		1.0		1.4	V

#### Notes:

1. Maximum  $I_{CC}$  specifications are tested with  $V_{CC} = V_{CCmax}$ .
2. The  $I_{CC}$  current listed is typically less than 2 mA/MHz, with OE# at  $V_{IH}$ .
3.  $I_{CC}$  active while Embedded Erase or Embedded Program is in progress.
4. Device enters automatic sleep mode when addresses are stable for  $t_{ACC} + 60 ns$ . Typical sleep mode current is equal to  $I_{CC3}$ .
5. Total current during accelerated programming is the sum of  $V_{ACC}$  and  $V_{CC}$  currents.
6. 80 MHz applies only to the WS064J.

## Test Conditions

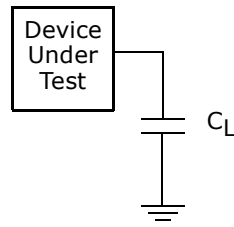

Figure II. Test Setup

Table 2I. Test Specifications

Test Condition	All Speed Options	Unit
Output Load Capacitance, $C_L$ (including jig capacitance)	30	pF
Input Rise and Fall Times	2.5 - 3	ns
Input Pulse Levels	0.0- $V_{CC}$	V
Input timing measurement reference levels	$V_{CC}/2$	V
Output timing measurement reference levels	$V_{CC}/2$	V

## Key to Switching Waveforms

Waveform	Inputs	Outputs
	Steady	
	Changing from H to L	
	Changing from L to H	
	Don't Care, Any Change Permitted	Changing, State Unknown
	Does Not Apply	Center Line is High Impedance State (High Z)

## Switching Waveforms

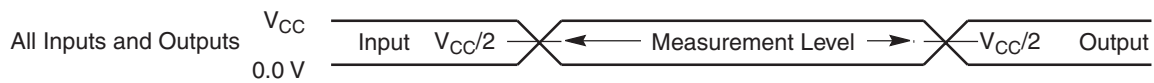

Figure I2. Input Waveforms and Measurement Levels

## AC Characteristics

### V<sub>CC</sub> Power-up

Parameter	Description	Test Setup	Speed	Unit
t <sub>VCS</sub>	V <sub>CC</sub> Setup Time	Min	50	μs
t <sub>RSTH</sub>	RESET# Low Hold Time	Min	50	μs

**Notes:**

- V<sub>CC</sub> ramp rate is > 1V / 100μs
- V<sub>CC</sub> ramp rate < 1V / 100μs, a Hardware Reset will be required.

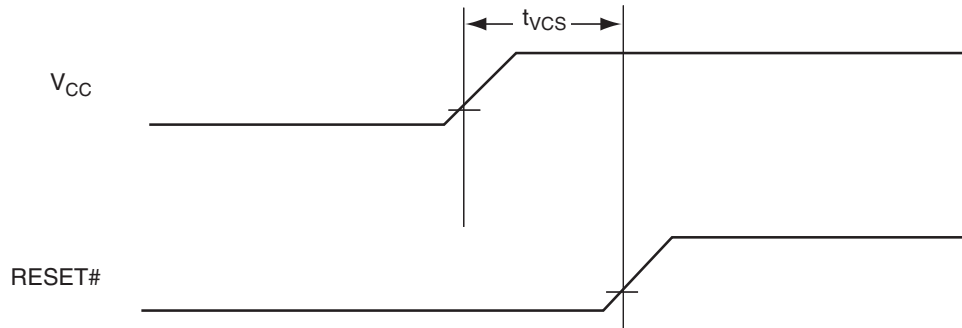
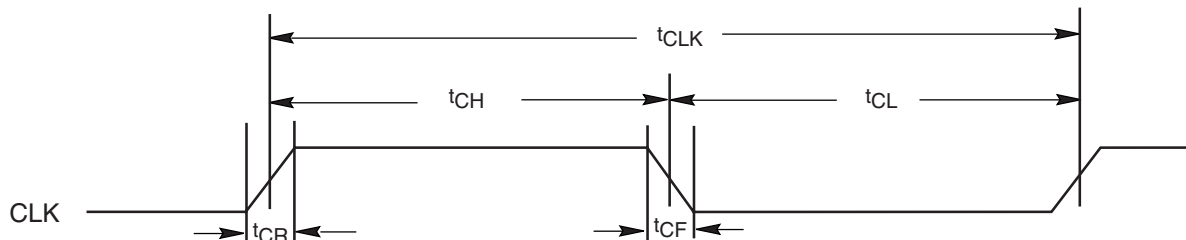

Figure I3. V<sub>CC</sub> Power-up Diagram

### CLK Characterization

Parameter	Description		66 MHz	80 MHz (WaitState=6,7)	80 MHz (WaitState less than 5)	Unit	Condition
f <sub>CLK</sub>	CLK Frequency	Max	66.0	80.0	66.0	MHz	
		Min	15.2	66.0	18.2	MHz	continuous burst , CLK duty 50% +/- 10%
		Min	32.0	-	32.0	KHz	8/16/32-word burst, CLK duty 50% +/- 10%
t <sub>CLKH</sub>	CLK high time	Min	39.6	-	33.0	ns	continuous burst
		Min	7	5	5	ns	8/16/32-word burst
t <sub>CLKL</sub>	CLK Low Time	Min	7.0	5.0	5.0	ns	
t <sub>CR</sub>	CLK Rise Time	Max	3	2.5	2.5	ns	
t <sub>CF</sub>	CLK Fall Time						

**Note:** 80 MHz applies only to the WS064J.



**Note:** For WS128J (model numbers 10 and 11), and additional clock cycle is required during boundary crossing while in continuous read mode.

Figure I4. CLK Characterization



## Synchronous/Burst Read

Parameter		Description		66 MHz	80 MHz (WS064J only)	Unit
JEDEC	Standard					
	t <sub>IACC</sub>	Latency (Standard wait-state Handshake mode) for 8-Word and Continuous 16-Word Burst	Max	56	71	ns
	t <sub>IACC</sub>	Latency (Standard wait-state Handshake mode) for 32-Word Burst	Max	71	84	ns
	t <sub>BACC</sub>	Burst Access Time Valid Clock to Output Delay	Max	11.2	9.1	ns
	t <sub>ACS</sub>	Address Setup Time to CLK (Note 1)	Min	4		ns
	t <sub>ACH</sub>	Address Hold Time from CLK (Note 1)	Min	5.5		ns
	t <sub>BDH</sub>	Data Hold Time from Next Clock Cycle	Min	2		ns
	t <sub>CR</sub>	Chip Enable to RDY Valid	Max	11.2	9.1	ns
	t <sub>OE</sub>	Output Enable to Output Valid	Max	11.2	9.1	ns
	t <sub>CEZ</sub>	Chip Enable to High Z	Max	8		ns
	t <sub>OEZ</sub>	Output Enable to High Z	Max	8		ns
	t <sub>CES</sub>	CE# Setup Time to CLK	Min	4		ns
	t <sub>RDYS</sub>	RDY Setup Time to CLK	Min	4		ns
	t <sub>RACC</sub>	Ready Access Time from CLK	Max	11.2	9.1	ns
	t <sub>AAS</sub>	Address Setup Time to AVD# (Note 1)	Min	4		ns
	t <sub>AAH</sub>	Address Hold Time to AVD# (Note 1)	Min	5.5		ns
	t <sub>CAS</sub>	CE# Setup Time to AVD#	Min	0		ns
	t <sub>AVC</sub>	AVD# Low to CLK	Min	4		ns
	t <sub>AVD</sub>	AVD# Pulse	Min	10		ns
	t <sub>ACC</sub>	Access Time	Max	55	55	ns
	t <sub>CKA</sub>	CLK to access resume	Max	11.2	9.1	ns
	t <sub>CKZ</sub>	CLK to High Z	Max	8		ns
	t <sub>OES</sub>	Output Enable Setup Time	Min	4		ns

**Notes:**

1. Addresses are latched on the first of either the active edge of CLK or the rising edge of AVD#.

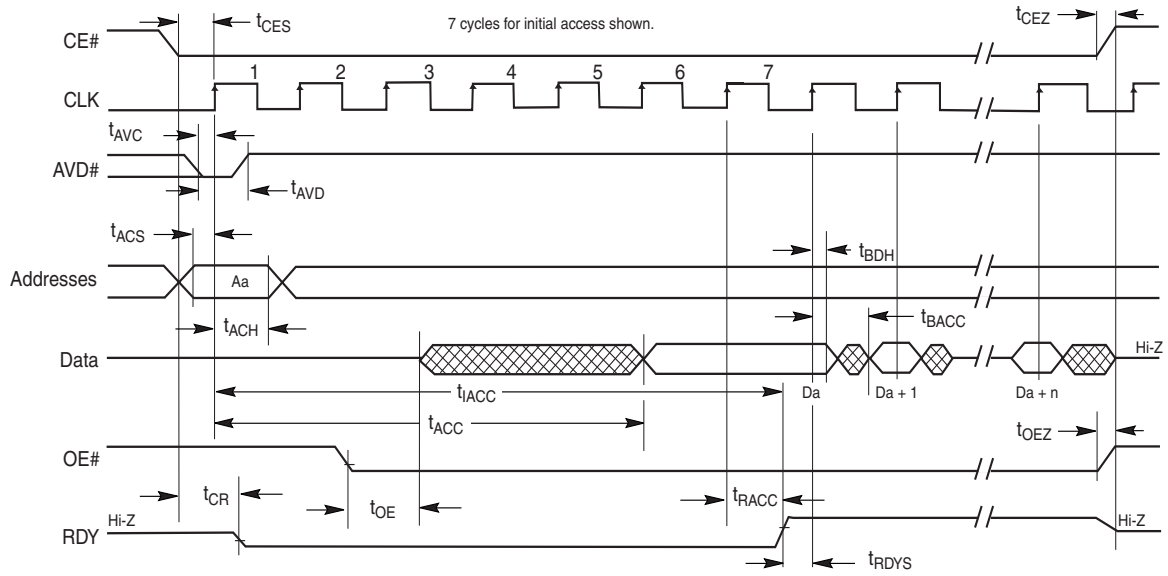

**Notes:**

1. Figure shows total number of wait states set to seven cycles. The total number of wait states can be programmed from two cycles to seven cycles.
2. If any burst address occurs at a 64-word boundary, two additional clock cycle when wait state is set to less than 5 or three additional clock cycle when wait state is set to 6 & 7 are inserted, and is indicated by RDY.
3. The device is in synchronous mode.

**Figure 15. CLK Synchronous Burst Mode Read (rising active CLK)**

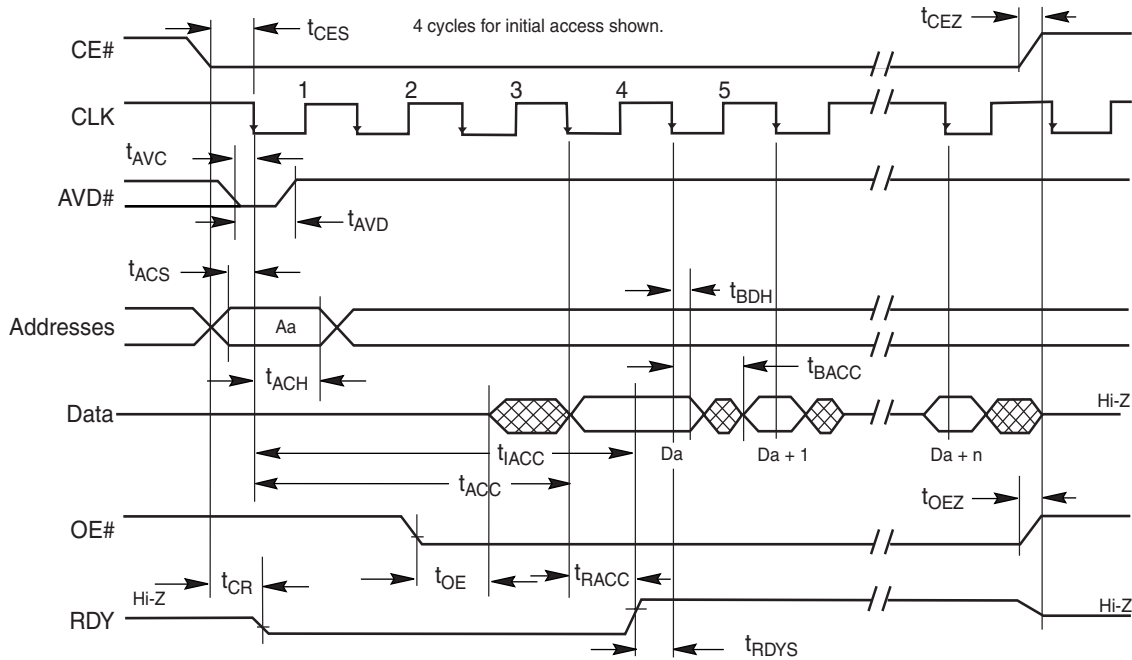

**Notes:**

1. Figure shows total number of wait states set to four cycles. The total number of wait states can be programmed from two cycles to seven cycles. Clock is set for active falling edge.
2. If any burst address occurs at a 64-word boundary, two additional clock cycle when wait state is set to less than 5 or three additional clock cycle when wait state is set to 6 & 7 are inserted, clock cycle are inserted, and is indicated by RDY.
3. The device is in synchronous mode.

**Figure 16. CLK Synchronous Burst Mode Read (Falling Active Clock)**

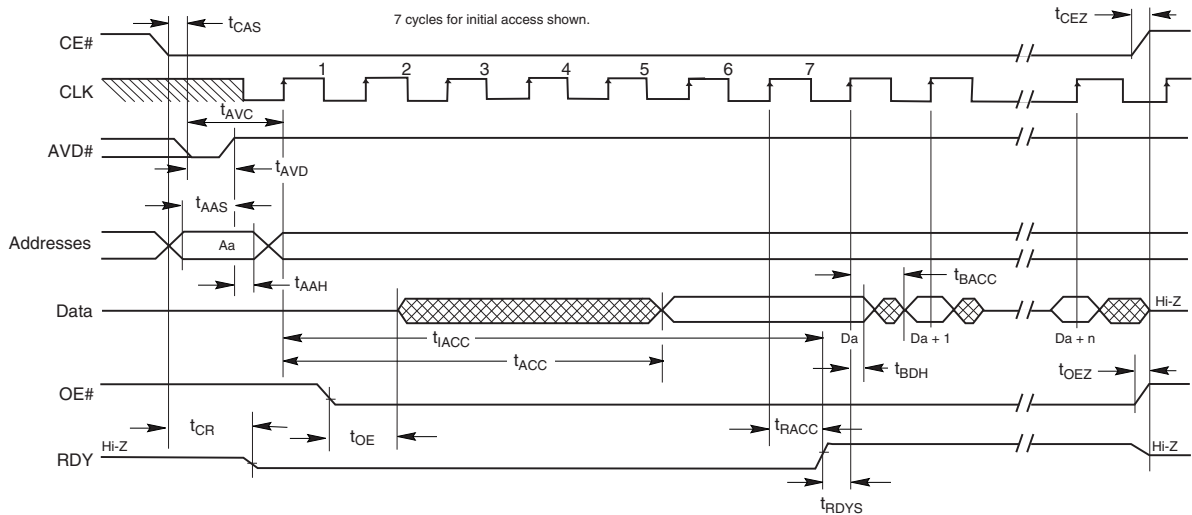

**Notes:**

1. Figure shows total number of wait states set to seven cycles. The total number of wait states can be programmed from two cycles to seven cycles. Clock is set for active rising edge.
2. If any burst address occurs at a 64-word boundary, two additional clock cycle are inserted, and is indicated by RDY.
3. The device is in synchronous mode.

**Figure 17. Synchronous Burst Mode Read**

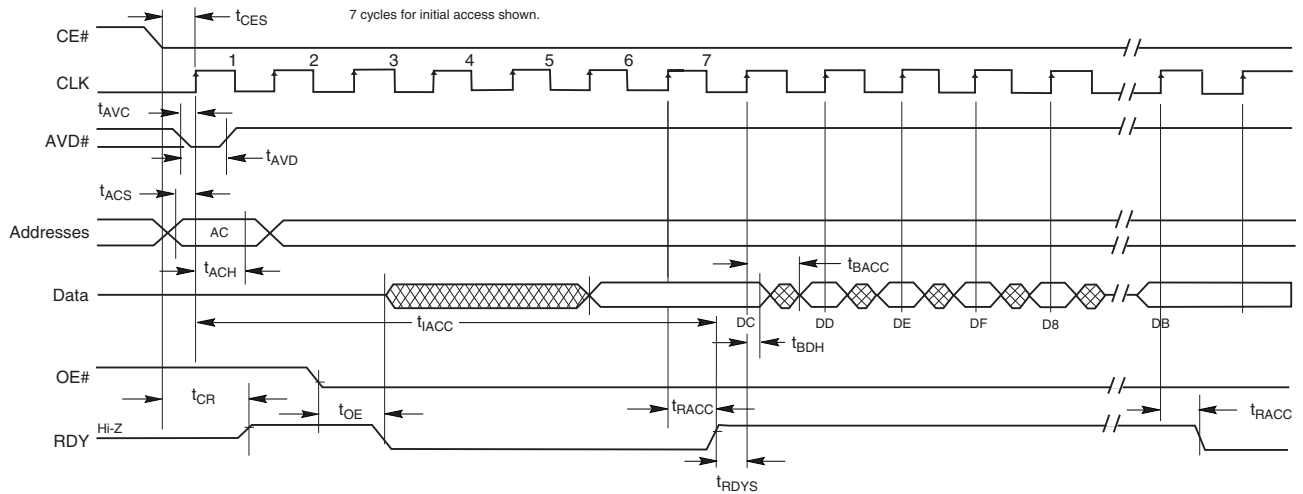

**Notes:**

1. Figure shows total number of wait states set to seven cycles. The total number of wait states can be programmed from two cycles to seven cycles. Clock is set for active rising edge.
2. If any burst address occurs at a 64-word boundary, two additional clock cycle are inserted, and is indicated by RDY.
3. The device is in synchronous mode with wrap around.
4. D0-D7 in data waveform indicates the order the data within a given 8-word address range, from lowest to highest. Starting address in figure is the 4th address in range (AC)

**Figure 18. 8-word Linear Burst with Wrap Around**

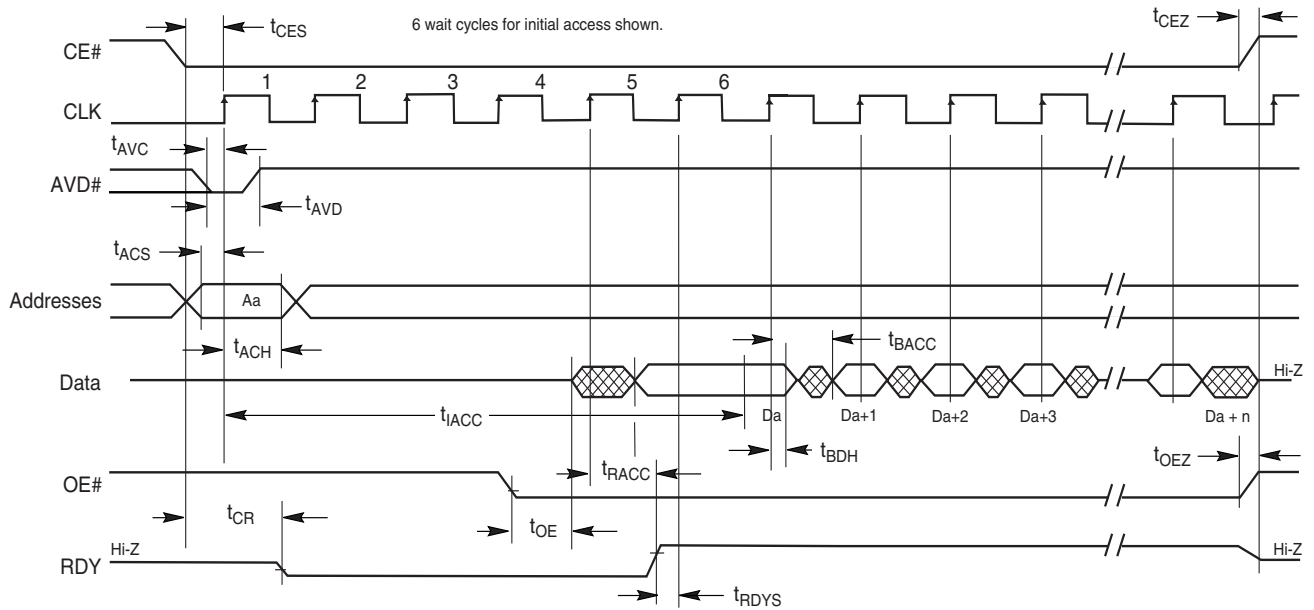

**Notes:**

1. Figure assumes 6 wait states for initial access and synchronous read.
2. The Set Configuration Register command sequence has been written with A18=0; device will output RDY one cycle before valid data.

**Figure 19. Linear Burst with RDY Set One Cycle Before Data**

### Asynchronous Mode Read

Parameter		Description		66 MHz	80 MHz (WS064J only)	Unit
JEDEC	Standard					
	$t_{CE}$	Access Time from CE# Low	Max	55	55	ns
	$t_{ACC}$	Asynchronous Access Time	Max	55	55	ns
	$t_{AVDP}$	AVD# Low Time	Min	10		ns
	$t_{AAVDS}$	Address Setup Time to Rising Edge of AVD	Min	4		ns
	$t_{AAVDH}$	Address Hold Time from Rising Edge of AVD	Min	5.5		ns
	$t_{OE}$	Output Enable to Output Valid	Max	11.2	9.1	ns
	$t_{OEh}$	Output Enable Hold Time	Read	0		ns
		Toggle and Data# Polling	Min	8		ns
	$t_{OEZ}$	Output Enable to High Z	Max	8		ns
	$t_{CAS}$	CE# Setup Time to AVD#	Min	0		ns

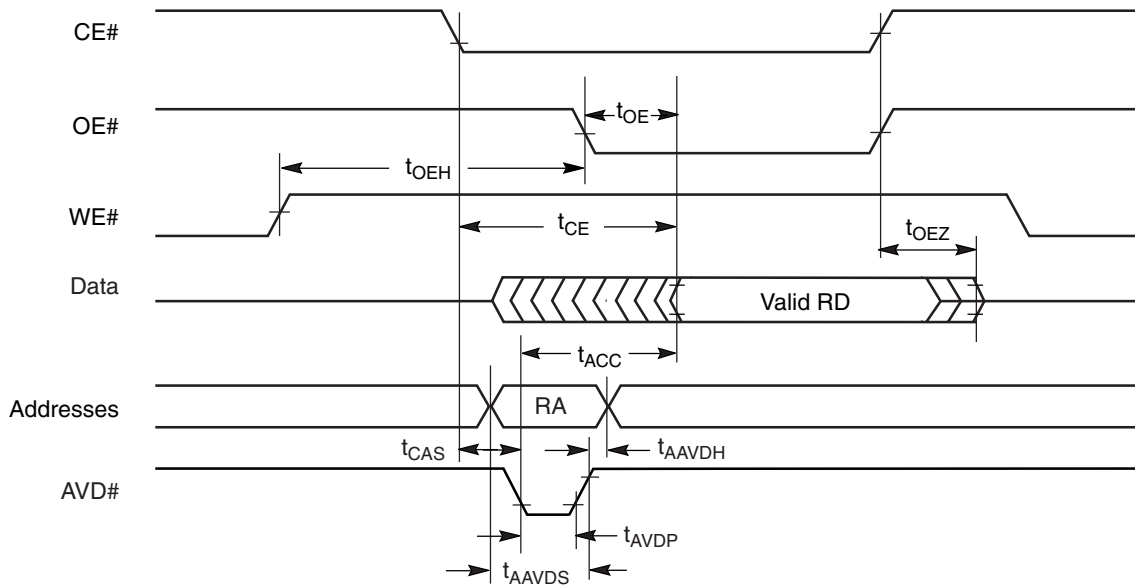

**Note:** RA = Read Address, RD = Read Data.

**Figure 20. Asynchronous Mode Read with Latched Addresses**

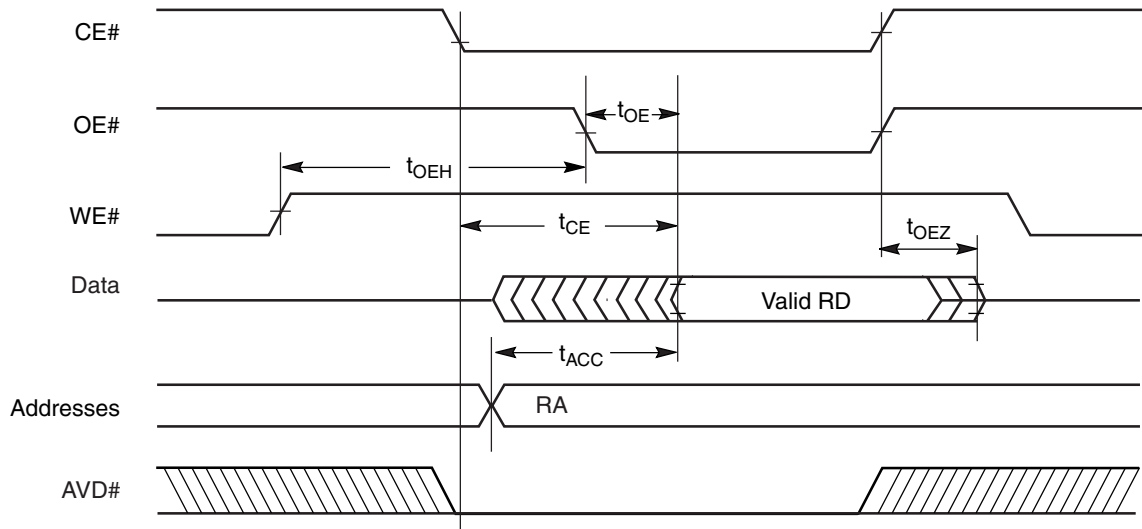

**Note:** RA = Read Address, RD = Read Data.

**Figure 21. Asynchronous Mode Read**

### Hardware Reset (RESET#)

Parameter		Description		All Speed Options	Unit
JEDEC	Std				
	$t_{Ready}$	RESET# Pin Low (During Embedded Algorithms) to Read Mode (See Note)	Max	35	$\mu s$
	$t_{Ready}$	RESET# Pin Low (NOT During Embedded Algorithms) to Read Mode (See Note)	Max	500	ns
	$t_{RP}$	RESET# Pulse Width	Min	500	ns
	$t_{RH}$	Reset High Time Before Read (See Note)	Min	200	ns
	$t_{RPD}$	RESET# Low to Standby Mode	Min	20	$\mu s$

**Note:** Not 100% tested.

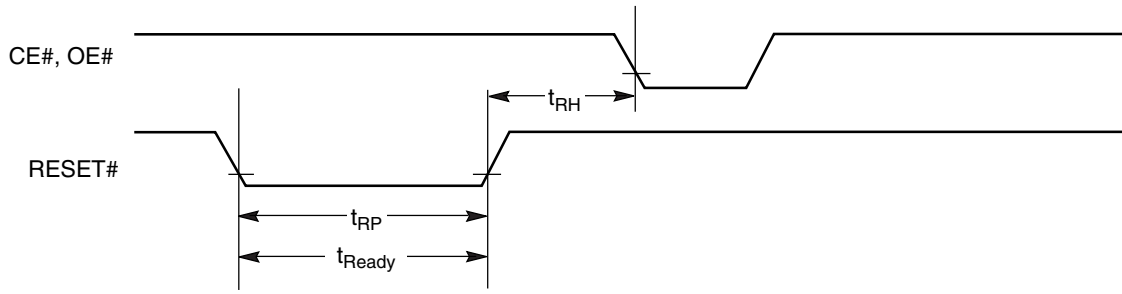

Reset Timings NOT during Embedded Algorithms

Reset Timings during Embedded Algorithms

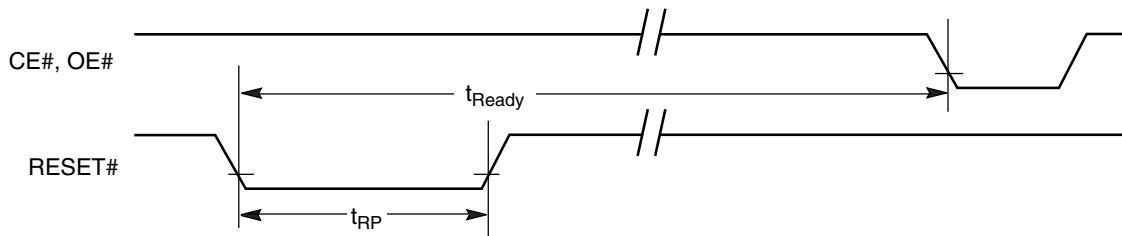

Figure 22. Reset Timings

### Erase/Program Operations

Parameter		Description		66 MHz	80 MHz (WS064J only)	Unit
JEDEC	Standard					
$t_{AVAV}$	$t_{WC}$	Write Cycle Time (Note 1)	Min	45		ns
$t_{AVWL}$	$t_{AS}$	Address Setup Time (Notes 2, 3)	Synchronous	Min	4	ns
			Asynchronous		0	
$t_{WLAX}$	$t_{AH}$	Address Hold Time (Notes 2, 3)	Synchronous	Min	5.5	ns
			Asynchronous		20	
	$t_{AVDP}$	AVD# Low Time	Min	10		ns
$t_{DVWH}$	$t_{DS}$	Data Setup Time	Min	20		ns
$t_{WHDX}$	$t_{DH}$	Data Hold Time	Min	0		ns
$t_{GHWL}$	$t_{GHWL}$	Read Recovery Time Before Write	Min	0		ns
	$t_{CAS}$	CE# Setup Time to AVD#	Min	0		ns
$t_{WHEH}$	$t_{CH}$	CE# Hold Time	Min	0		ns
$t_{WLWH}$	$t_{WP}$	Write Pulse Width	Min	20		ns
$t_{WHWL}$	$t_{WPH}$	Write Pulse Width High	Min	20		ns
	$t_{SR/W}$	Latency Between Read and Write Operations	Min	0		ns
$t_{WHWH1}$	$t_{WHWH1}$	Programming Operation (Note 4)	Typ	<7		$\mu$ s
$t_{WHWH1}$	$t_{WHWH1}$	Accelerated Programming Operation (Note 4)	Typ	<4		$\mu$ s
$t_{WHWH2}$	$t_{WHWH2}$	Sector Erase Operation (Notes 4, 5)	Typ	<0.2		sec
		Chip Erase Operation (Notes 4, 5)		<104		
	$t_{VID}$	$V_{ACC}$ Rise and Fall Time	Min	500		ns
	$t_{VIDS}$	$V_{ACC}$ Setup Time (During Accelerated Programming)	Min	1		$\mu$ s
	$t_{VCS}$	$V_{CC}$ Setup Time	Min	50		$\mu$ s
$t_{ELWL}$	$t_{CS}$	CE# Setup Time to WE#	Min	0		ns
	$t_{AVSW}$	AVD# Setup Time to WE#	Min	4		ns
	$t_{AVHW}$	AVD# Hold Time to WE#	Min	4		ns
	$t_{AVHC}$	AVD# Hold Time to CLK	Min	4		ns
	$t_{CSW}$	Clock Setup Time to WE#	Min	5		ns

**Notes:**

1. Not 100% tested.
2. Asynchronous mode allows both Asynchronous and Synchronous program operation. Synchronous mode allows both Asynchronous and Synchronous program operation.
3. In asynchronous program operation timing, addresses are latched on the falling edge of WE# or rising edge of AVD#. In synchronous program operation timing, addresses are latched on the first of either the rising edge of AVD# or the active edge of CLK.
4. See the [Erase and Programming Performance](#) section for more information.
5. Does not include the preprogramming time.



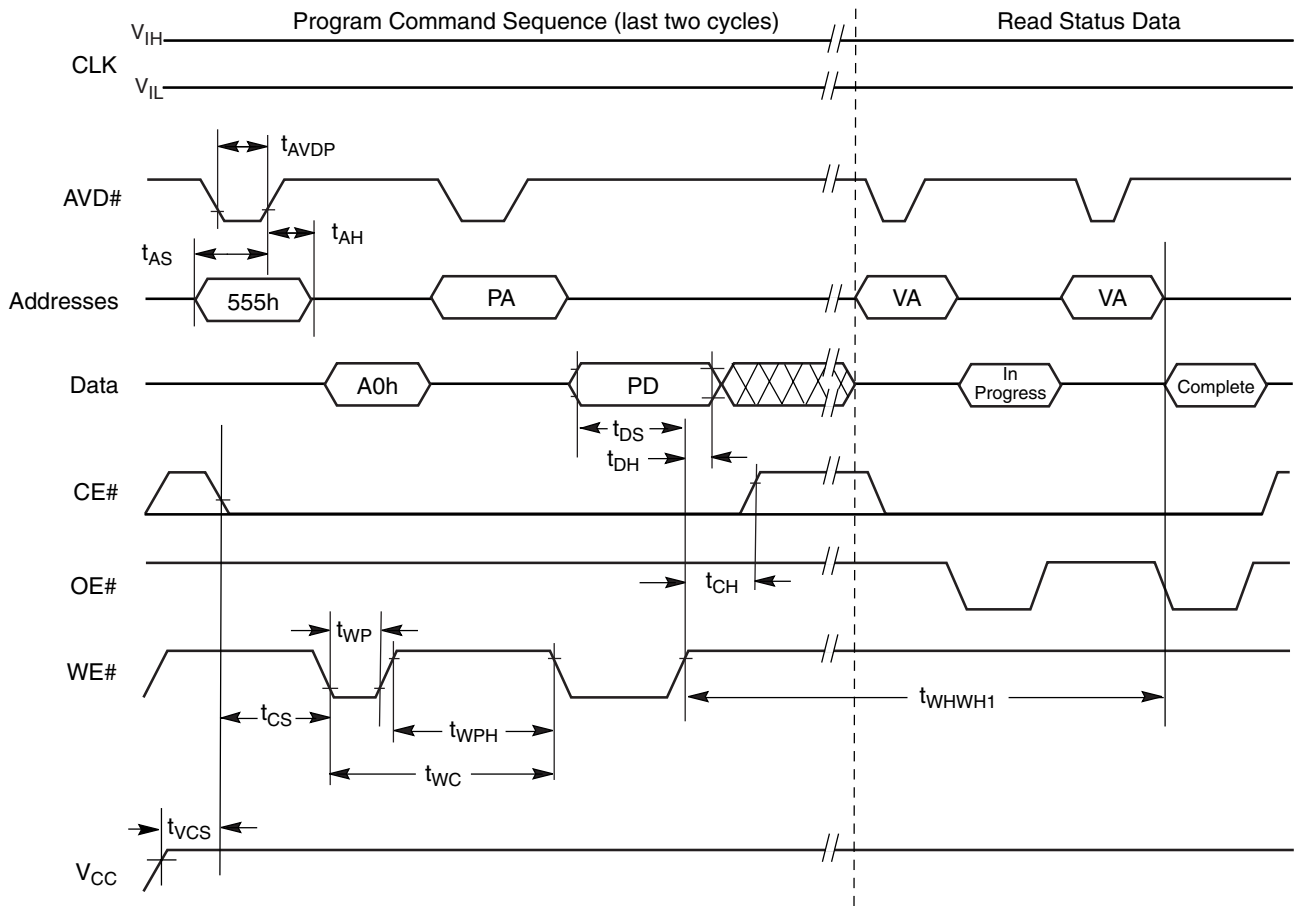

**Notes:**

1. PA = Program Address, PD = Program Data, VA = Valid Address for reading status bits.
2. "In progress" and "complete" refer to status of program operation.
3. A22-A12 are don't care during command sequence unlock cycles.
4. CLK can be either  $V_{IL}$  or  $V_{IH}$ .
5. The Asynchronous programming operation is independent of the Set Device Read Mode bit in the Configuration Register.

**Figure 23. Asynchronous Program Operation Timings: AVD# Latched Addresses**

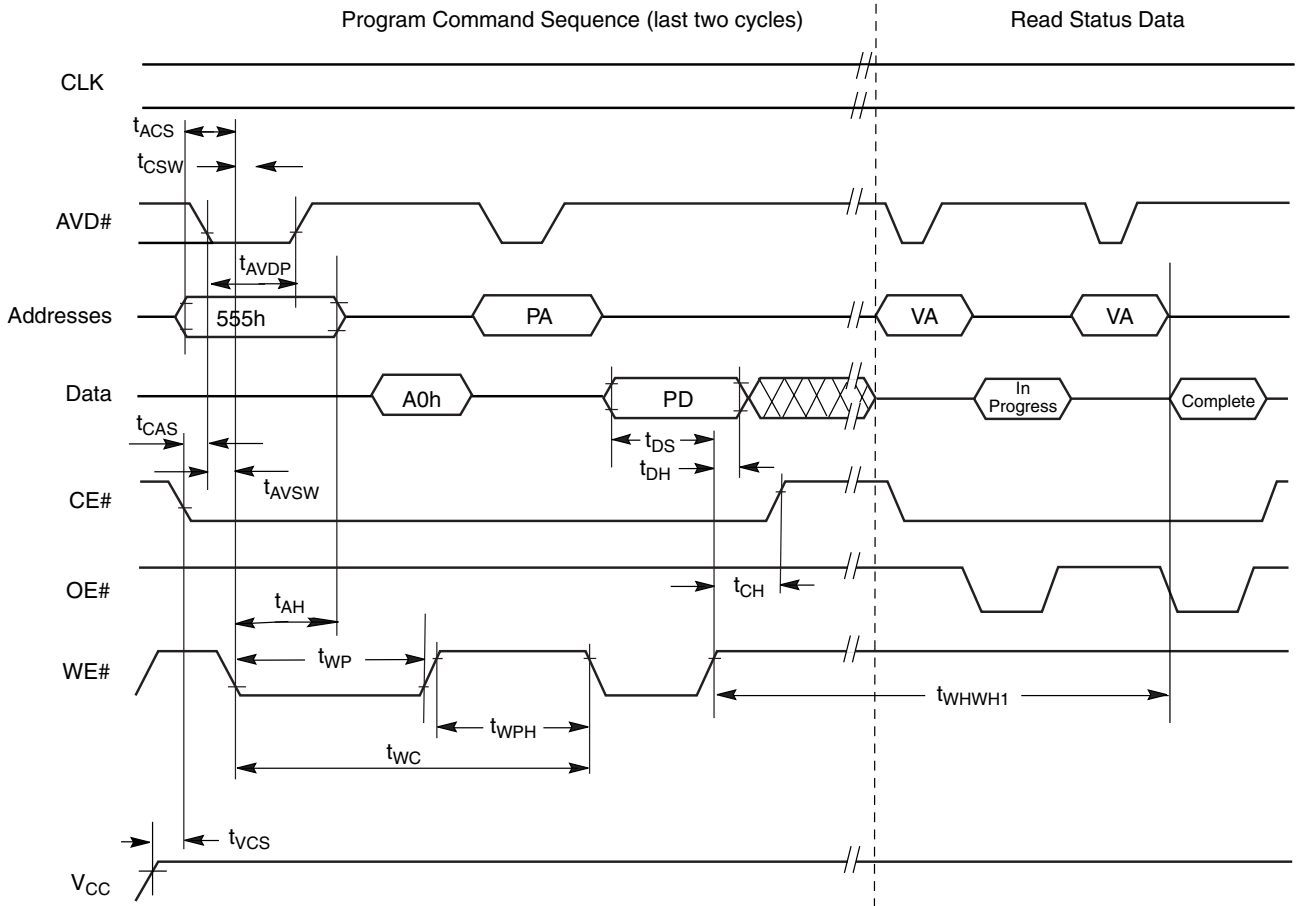

**Notes:**

1. PA = Program Address, PD = Program Data, VA = Valid Address for reading status bits.
2. "In progress" and "complete" refer to status of program operation.
3. A22-A12 are don't care during command sequence unlock cycles.
4. CLK can be either  $V_{IL}$  or  $V_{IH}$ .
5. The Asynchronous programming operation is independent of the Set Device Read Mode bit in the Configuration Register.

**Figure 24. Asynchronous Program Operation Timings: WE# Latched Addresses**

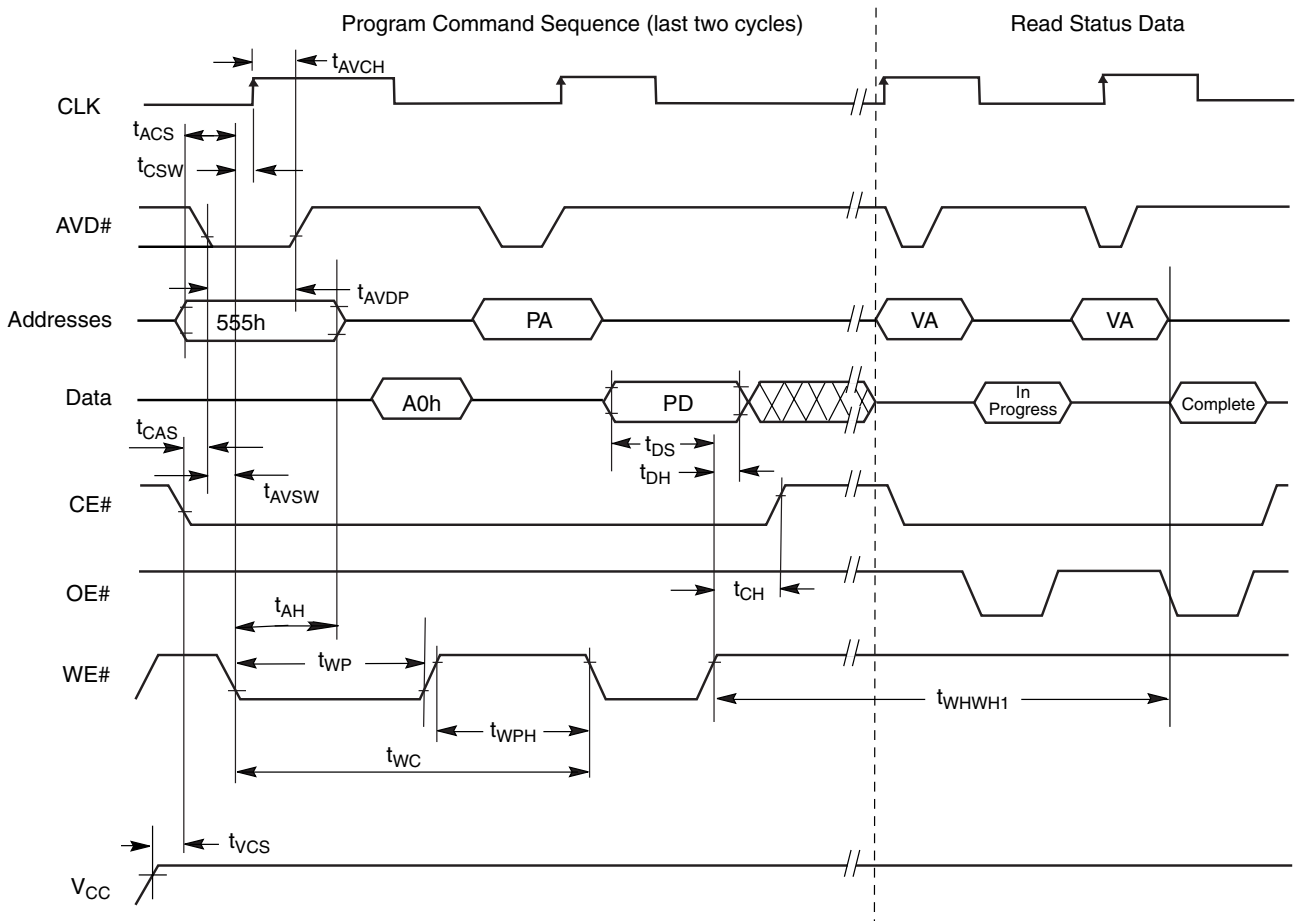

**Notes:**

1. PA = Program Address, PD = Program Data, VA = Valid Address for reading status bits.
2. "In progress" and "complete" refer to status of program operation.
3. A22-A12 are don't care during command sequence unlock cycles.
4. Addresses are latched on the first of either the rising edge of AVD# or the active edge of CLK.
5. Either CE# or AVD# is required to go from low to high in between programming command sequences.
6. The Synchronous programming operation is dependent of the Set Device Read Mode bit in the Configuration Register. The Configuration Register must be set to the Synchronous Read Mode.

**Figure 25. Synchronous Program Operation Timings: WE# Latched Addresses**

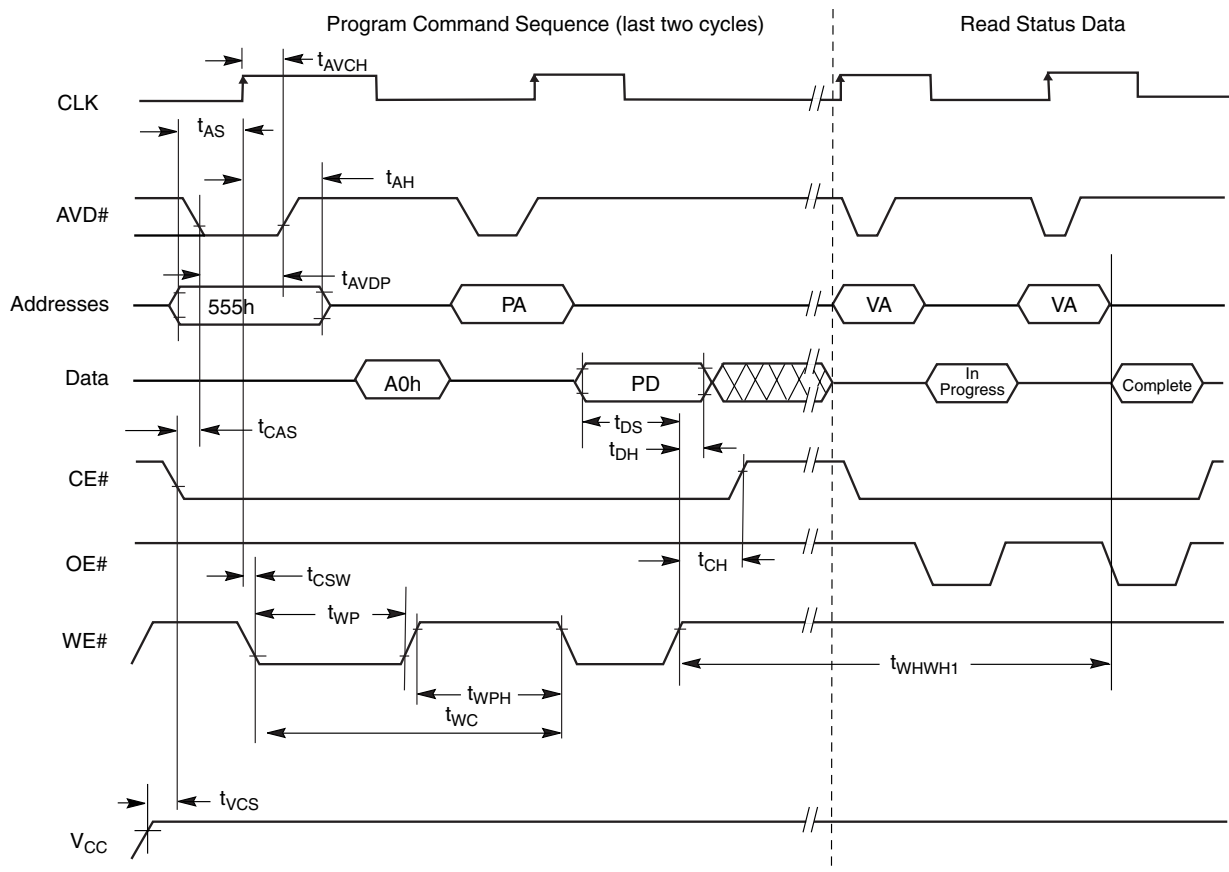

**Notes:**

1. PA = Program Address, PD = Program Data, VA = Valid Address for reading status bits.
2. "In progress" and "complete" refer to status of program operation.
3. A22-A12 are don't care during command sequence unlock cycles.
4. Addresses are latched on the first of either the rising edge of AVD# or the active edge of CLK.
5. Either CE# or AVD# is required to go from low to high in between programming command sequences.
6. The Synchronous programming operation is dependent of the Set Device Read Mode bit in the Configuration Register. The Configuration Register must be set to the Synchronous Read Mode.

**Figure 26. Synchronous Program Operation Timings: CLK Latched Addresses**

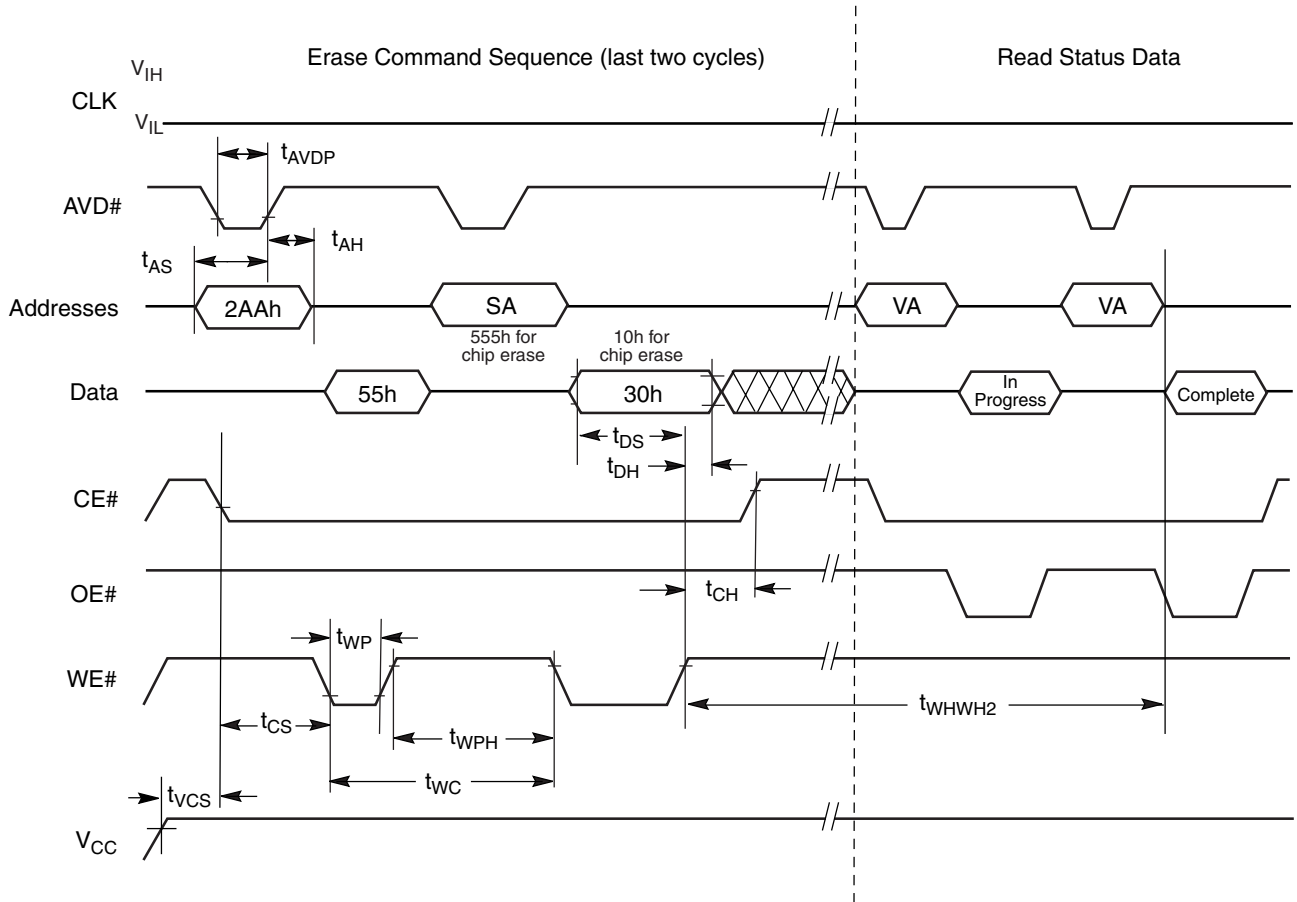

**Notes:**

1. SA is the sector address for Sector Erase.
2. Address bits A22–A12 are don't cares during unlock cycles in the command sequence.

**Figure 27. Chip/Sector Erase Command Sequence**

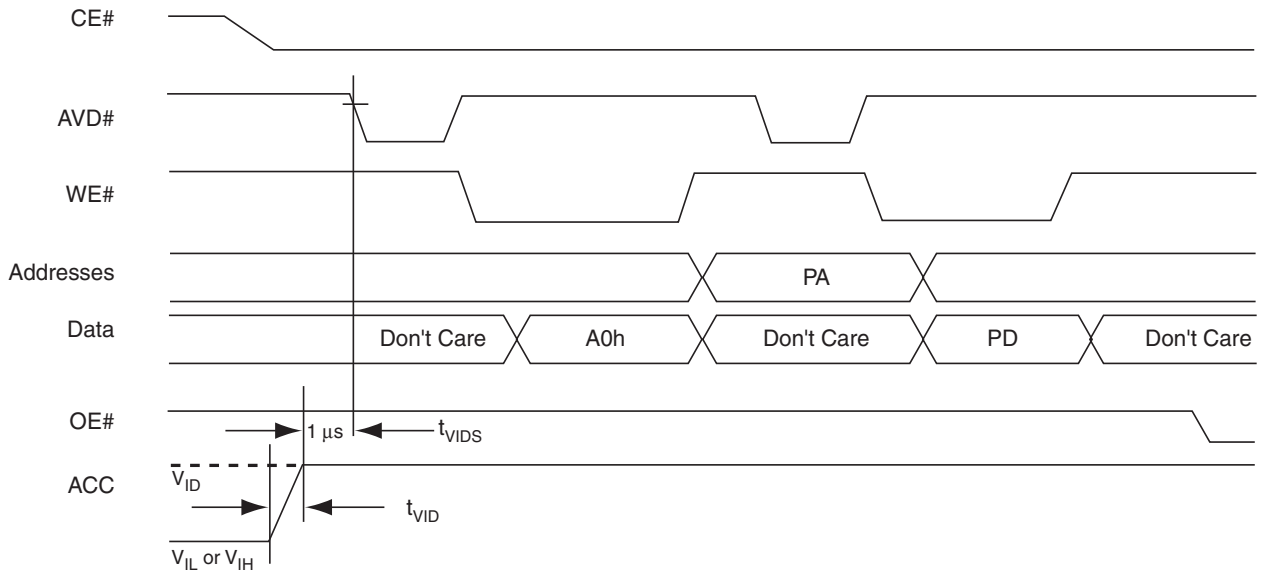

**Note:** Use setup and hold times from conventional program operation.

**Figure 28. Accelerated Unlock Bypass Programming Timing**

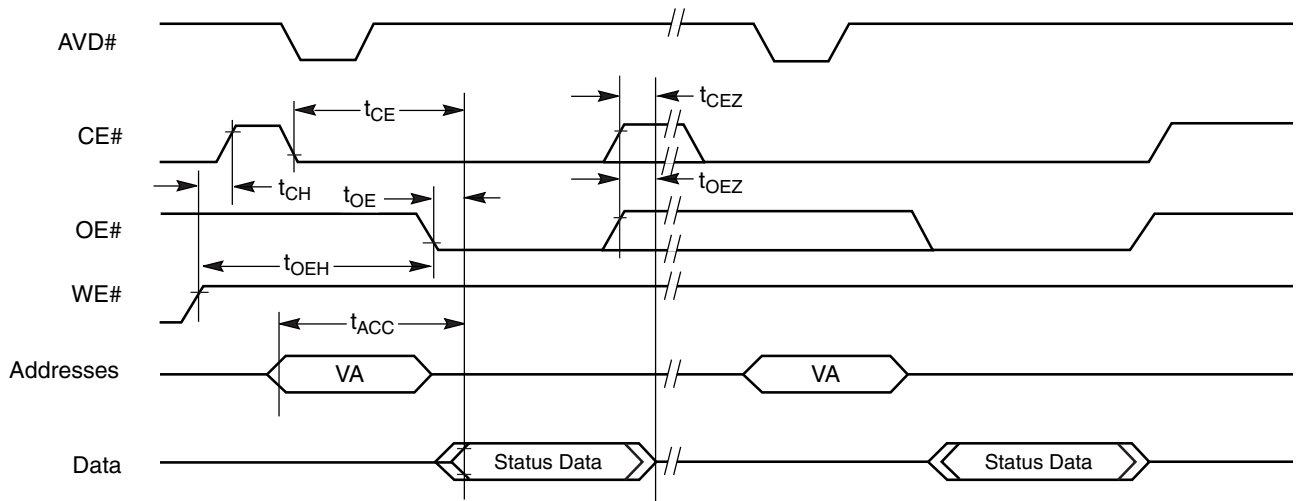

**Notes:**

1. Status reads in figure are shown as asynchronous.
2. VA = Valid Address. Two read cycles are required to determine status. When the Embedded Algorithm operation is complete, and Data# Polling will output true data.
3. While in Asynchronous mode, RDY will be low while the device is in embedded erase or programming mode.

**Figure 29. Data# Polling Timings (During Embedded Algorithm)**

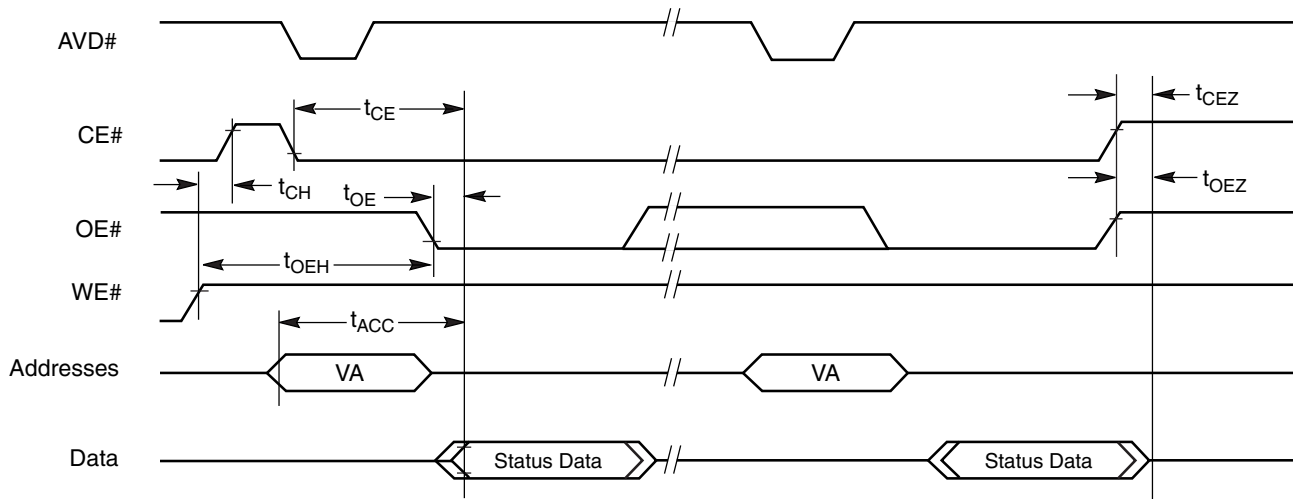

**Notes:**

1. Status reads in figure are shown as asynchronous.
2. VA = Valid Address. Two read cycles are required to determine status. When the Embedded Algorithm operation is complete, the toggle bits will stop toggling.
3. While in Asynchronous mode, RDY will be low while the device is in embedded erase or programming mode.

**Figure 30. Toggle Bit Timings (During Embedded Algorithm)**

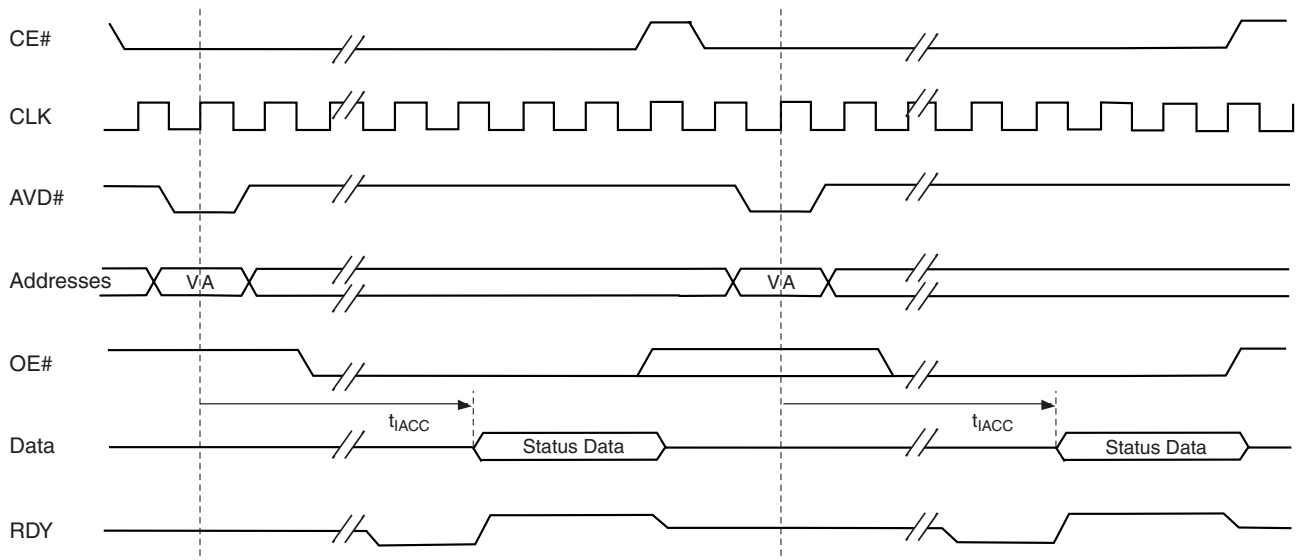

**Notes:**

1. The timings are similar to synchronous read timings.
2. VA = Valid Address. Two read cycles are required to determine status. When the Embedded Algorithm operation is complete, the toggle bits will stop toggling.
3. RDY is active with data (A18 = 0 in the Configuration Register). When A18 = 1 in the Configuration Register, RDY is active one clock cycle before data.

**Figure 31. Synchronous Data Polling Timings/Toggle Bit Timings**

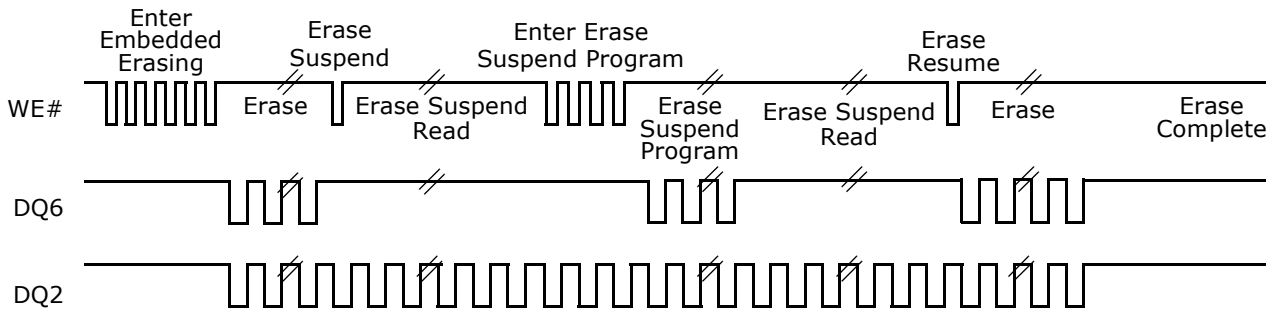

**Note:** DQ2 toggles only when read at an address within an erase-suspended sector. The system may use OE# or CE# to toggle DQ2 and DQ6.

Figure 32. DQ2 vs. DQ6

### Temporary Sector Unprotect

Parameter		Description		All Speed Options	Unit
JEDEC	Std				
	$t_{VIDR}$	$V_{ID}$ Rise and Fall Time (See Note)	Min	500	ns
	$t_{VHH}$	$V_{HH}$ Rise and Fall Time (See Note)	Min	250	ns
	$t_{RSP}$	RESET# Setup Time for Temporary Sector Unprotect	Min	4	$\mu$ s
	$t_{RRB}$	RESET# Hold Time from RDY High for Temporary Sector Unprotect	Min	4	$\mu$ s

**Note:** Not 100% tested.

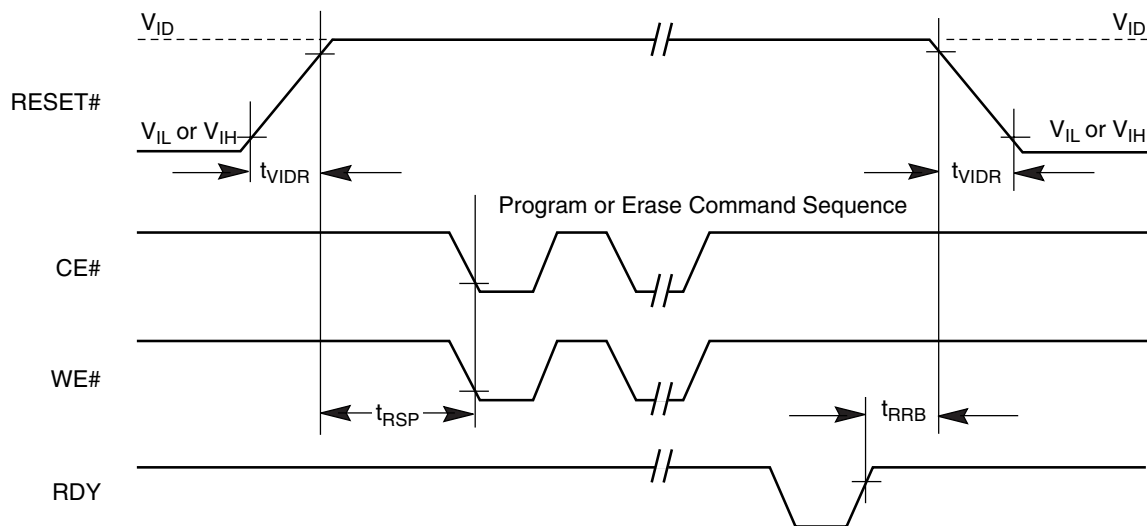
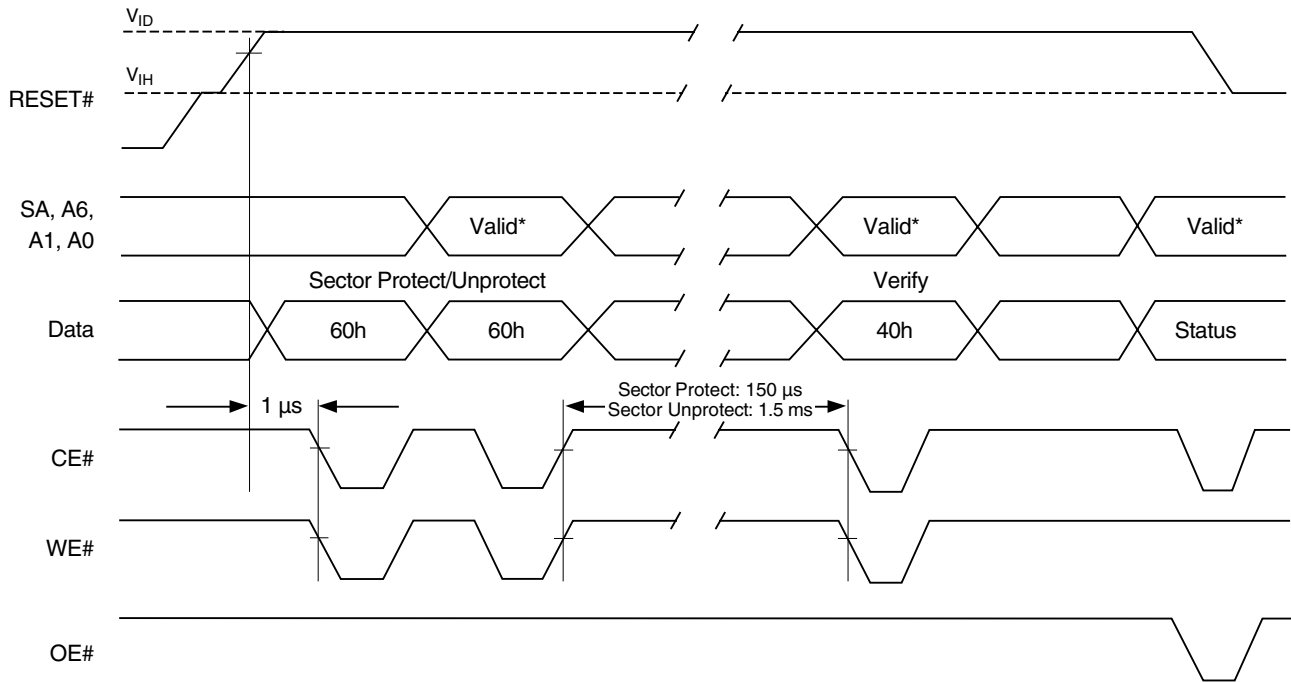

Figure 33. Temporary Sector Unprotect Timing Diagram





**Note:** For sector protect, A6 = 0, A1 = 1, A0 = 0. For sector unprotect, A6 = 1, A1 = 1, A0 = 0.

**Figure 34. Sector/Block Protect and Unprotect Timing Diagram**

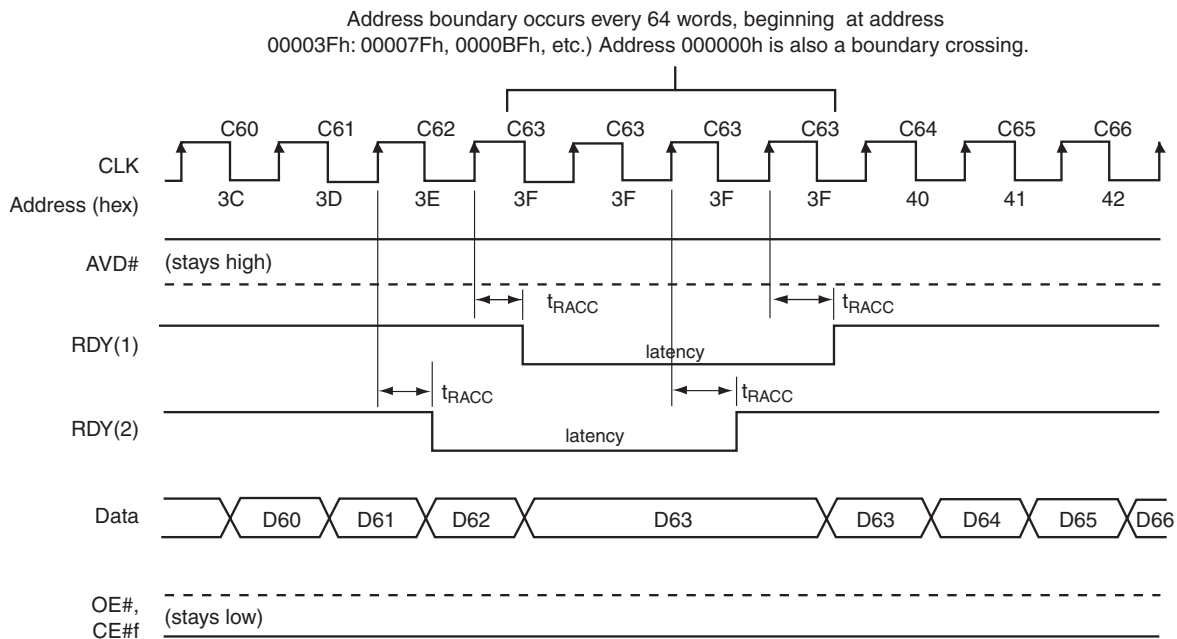

**Notes:**

1. RDY active with data (A18 = 0 in the Configuration Register).
2. RDY active one clock cycle before data (A18 = 1 in the Configuration Register).
3. Cxx indicates the clock that triggers Dxx on the outputs; for example, C60 triggers D60. Figure shows the device not crossing a bank in the process of performing an erase or program.
4. If the starting address latched in is either 3Eh or 3Fh (or some 64 multiple of either), there is no additional 2 cycle latency at the boundary crossing.

**Figure 35. Latency with Boundary Crossing**

Address boundary occurs every 64 words, beginning at address 00003Fh: (00007Fh, 0000BFh, etc.) Address 000000h is also a boundary crossing.

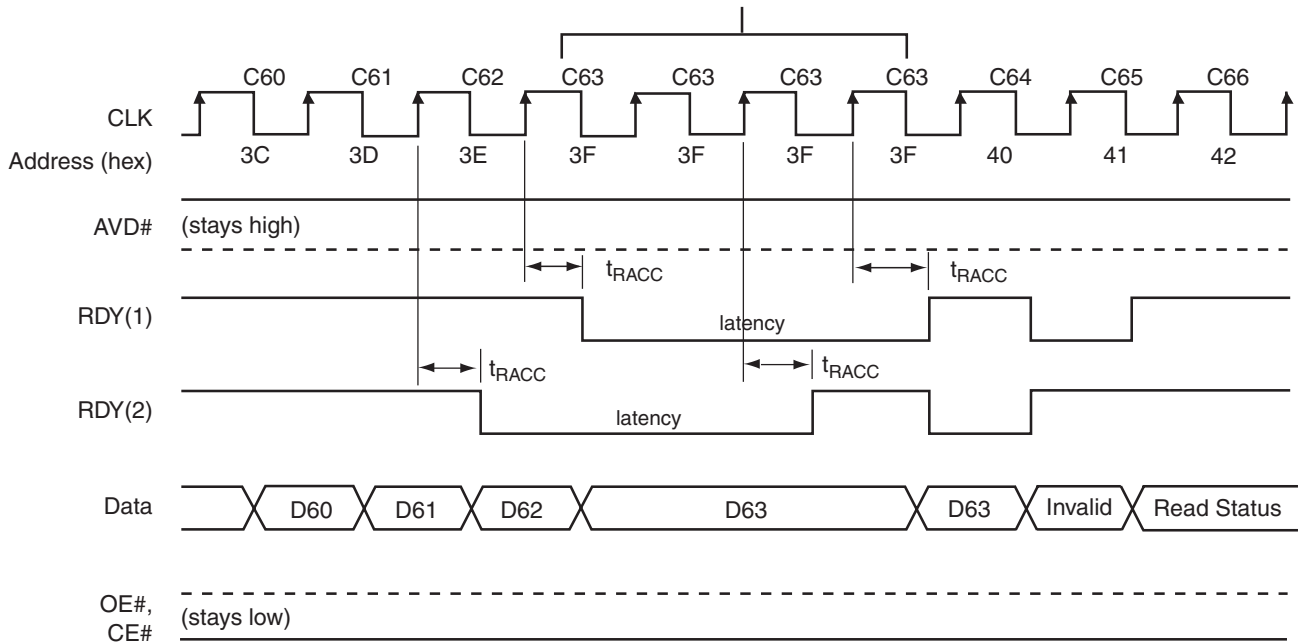

**Notes:**

1. RDY active with data (A18 = 0 in the Configuration Register).
2. RDY active one clock cycle before data (A18 = 1 in the Configuration Register).
3. Cxx indicates the clock that triggers Dxx on the outputs; for example, C60 triggers D60. Figure shows the device crossing a bank in the process of performing an erase or program.

**Figure 36. Latency with Boundary Crossing into Program/Erase Bank**

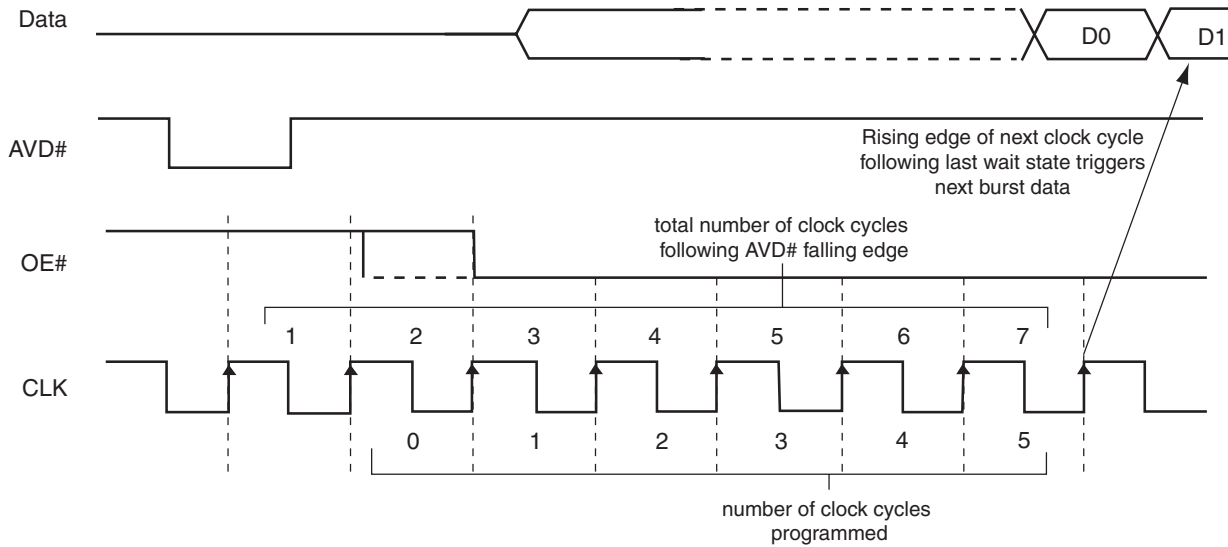

**Wait State Decoding Addresses:**

*A14, A13, A12 = "111" ⇒ Reserved*

*A14, A13, A12 = "110" ⇒ Reserved*

*A14, A13, A12 = "101" ⇒ 5 programmed, 7 total*

*A14, A13, A12 = "100" ⇒ 4 programmed, 6 total*

*A14, A13, A12 = "011" ⇒ 3 programmed, 5 total*

*A14, A13, A12 = "010" ⇒ 2 programmed, 4 total*

*A14, A13, A12 = "001" ⇒ 1 programmed, 3 total*

*A14, A13, A12 = "000" ⇒ 0 programmed, 2 total*

**Note:** Figure assumes address D0 is not at an address boundary, active clock edge is rising, and wait state is set to "101".

**Figure 37. Example of Wait States Insertion**

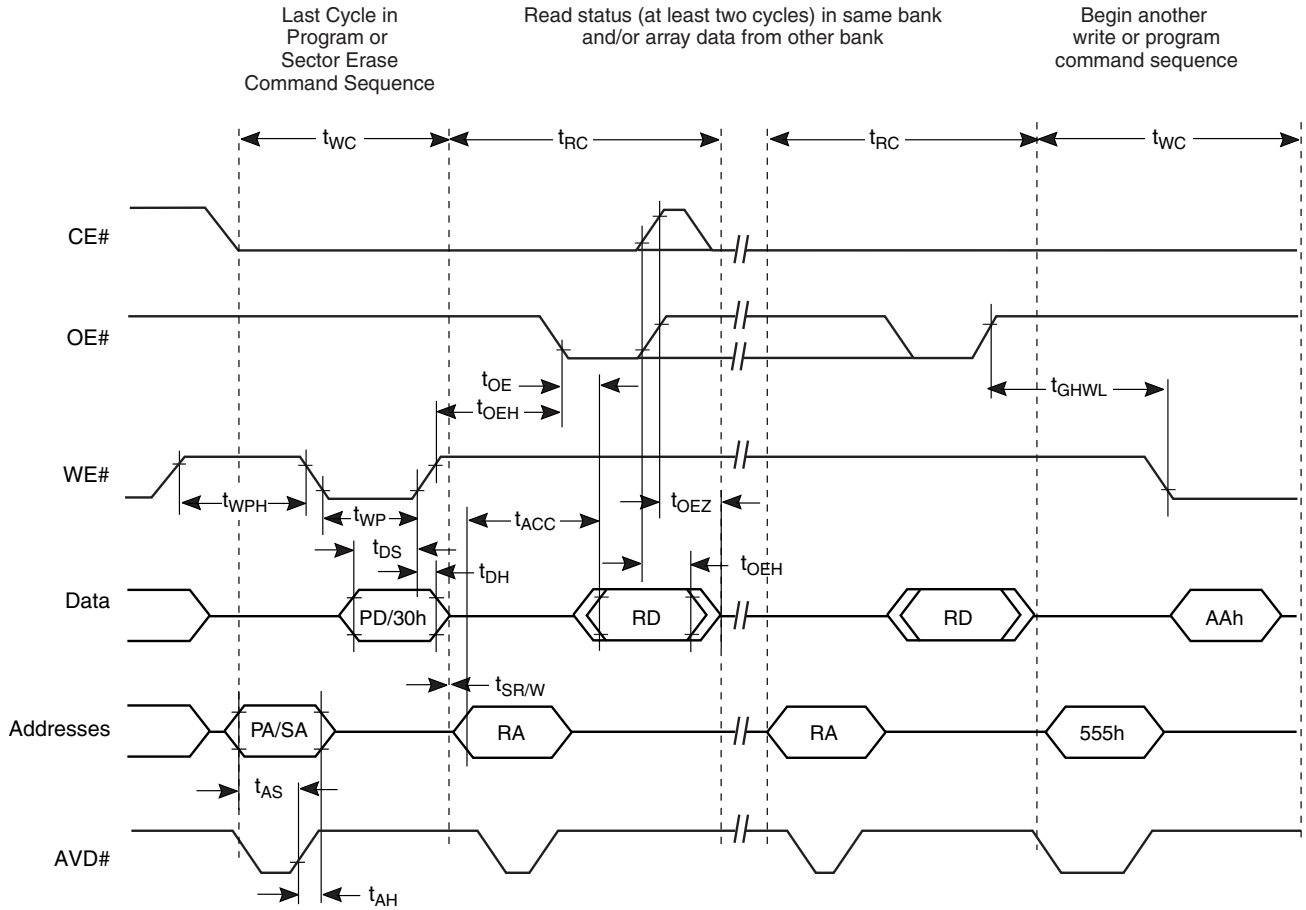

**Note:** Breakpoints in waveforms indicate that system may alternately read array data from the "non-busy bank" while checking the status of the program or erase operation in the "busy" bank. The system should read status twice to ensure valid information.

**Figure 38. Back-to-Back Read/Write Cycle Timings**

## Erase and Programming Performance

Parameter		Typ (Note 1)	Max (Note 2)	Unit	Comments
Sector Erase Time	32 Kword	<0.4	<2	s	Excludes 00h programming prior to erasure (Note 4)
	4 Kword	<0.2	<2		
Chip Erase Time	128J	<103		s	
	064J	<53			
Word Programming Time		<6	<100	μs	Excludes system level overhead (Note 5)
Accelerated Word Programming Time		<4	<67	μs	
Chip Programming Time (Note 3)	128J	<50.4		s	Excludes system level overhead (Note 5)
	064J	<25.2			
Accelerated Chip Programming Time	128J	<33		s	
	064J	<17			

### Notes:

1. Typical program and erase times assume the following conditions: 25°C, 1.8 V  $V_{CC}$ , 100K cycles. Additionally, programming typicals assumes a checkerboard pattern.
2. Under worst case conditions of 90°C,  $V_{CC} = 1.65$  V, 1,000,000 cycles.
3. The typical chip programming time is considerably less than the maximum chip programming time listed.
4. In the pre-programming step of the Embedded Erase algorithm, all words are programmed to 00h before erasure.
5. System-level overhead is the time required to execute the two- or four-bus-cycle sequence for the program command. See Table 18, "Command Definitions," on page 60 for further information on command definitions.
6. The device has a minimum erase and program cycle endurance of 100,000 cycles.

# Physical Dimensions

## VBH084 - 84-ball Fine-Pitch Ball Grid Array (FBGA) 8x11.6 mm MCP Compatible Package (I28Mb)

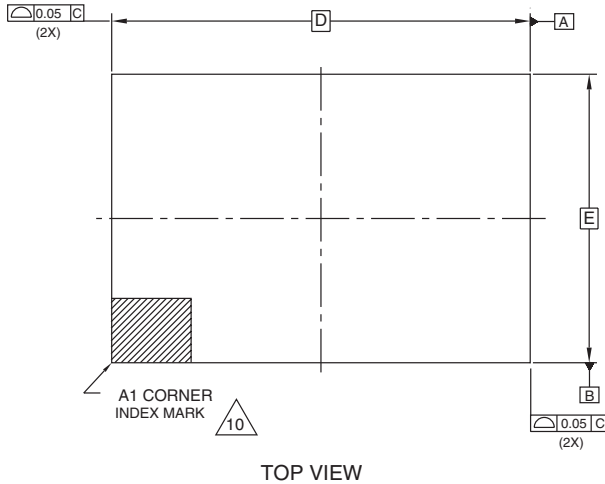

TOP VIEW

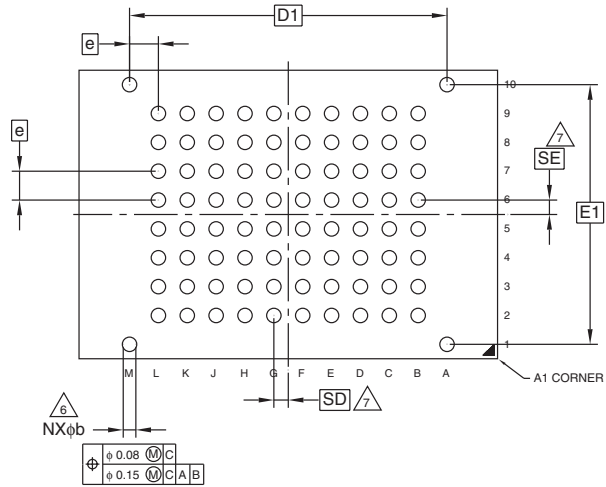

BOTTOM VIEW

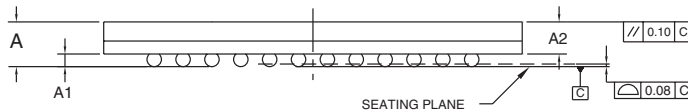

SIDE VIEW

PACKAGE	VBH 084			NOTE
JEDEC	N/A			
	11.60 mm x 8.00 mm NOM PACKAGE			
SYMBOL	MIN	NOM	MAX	NOTE
A	---	---	1.00	OVERALL THICKNESS
A1	0.18	---	---	BALL HEIGHT
A2	0.62	---	0.76	BODY THICKNESS
D	11.60 BSC.			BODY SIZE
E	8.00 BSC.			BODY SIZE
D1	8.80 BSC.			BALL FOOTPRINT
E1	7.20 BSC.			BALL FOOTPRINT
MD	12			ROW MATRIX SIZE D DIRECTION
ME	10			ROW MATRIX SIZE E DIRECTION
N	84			TOTAL BALL COUNT
φb	0.33	---	0.43	BALL DIAMETER
e	0.80 BSC.			BALL PITCH
SD / SE	0.40 BSC.			SOLDER BALL PLACEMENT
	(A2-A9, B10-L10, M2-M9, B1-L1)			DEPOPULATED SOLDER BALLS

NOTES:

1. DIMENSIONING AND TOLERANCING PER ASME Y14.5M-1994.
2. ALL DIMENSIONS ARE IN MILLIMETERS.
3. BALL POSITION DESIGNATION PER JESD 95-1, SPP-010 (EXCEPT AS NOTED).
4.  $e$  REPRESENTS THE SOLDER BALL GRID PITCH.
5. SYMBOL "MD" IS THE BALL ROW MATRIX SIZE IN THE "D" DIRECTION.  
SYMBOL "ME" IS THE BALL COLUMN MATRIX SIZE IN THE "E" DIRECTION.

N IS THE TOTAL NUMBER OF SOLDER BALLS.

- 6. DIMENSION "b" IS MEASURED AT THE MAXIMUM BALL DIAMETER IN A PLANE PARALLEL TO DATUM C.
- 7. SD AND SE ARE MEASURED WITH RESPECT TO DATUMS A AND B AND DEFINE THE POSITION OF THE CENTER SOLDER BALL IN THE OUTER ROW.

WHEN THERE IS AN ODD NUMBER OF SOLDER BALLS IN THE OUTER ROW PARALLEL TO THE D OR E DIMENSION, RESPECTIVELY, SD OR SE = 0.000.

WHEN THERE IS AN EVEN NUMBER OF SOLDER BALLS IN THE OUTER ROW, SD OR SE =  $e/2$

8. NOT USED.
9. "+" INDICATES THE THEORETICAL CENTER OF DEPOPULATED BALLS.
10. A1 CORNER TO BE IDENTIFIED BY CHAMFER, LASER OR INK MARK, METALLIZED MARK INDENTATION OR OTHER MEANS.

**Note:** BSC is an ANSI standard for Basic Space Centering

### VBR080 - 80-ball Fine-Pitch Ball Grid Array (FBGA) 7 x 9 mm (64Mb)

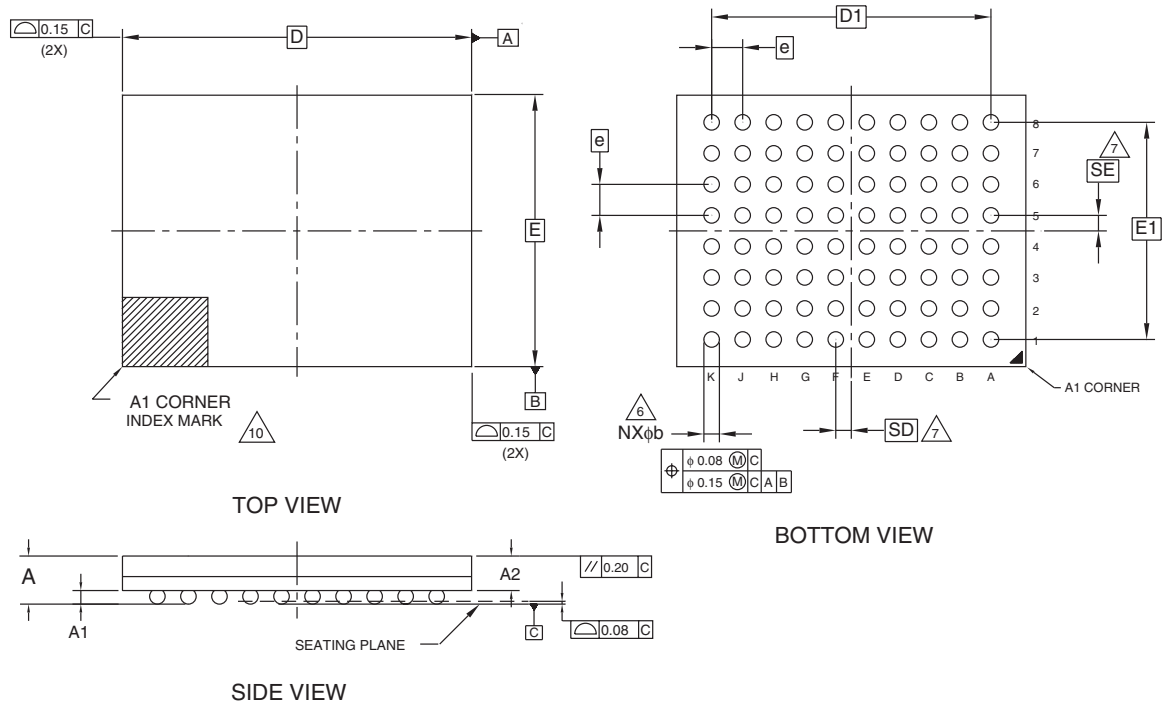

PACKAGE	VBR 080			NOTE
JEDEC	N/A			
	9.00 mm x 7.00 mm NOM PACKAGE			
SYMBOL	MIN	NOM	MAX	
A	---	---	1.00	OVERALL THICKNESS
A1	0.17	---	---	BALL HEIGHT
A2	0.62	---	0.73	BODY THICKNESS
D	9.00 BSC.			BODY SIZE
E	7.00 BSC.			BODY SIZE
D1	7.20 BSC.			BALL FOOTPRINT
E1	5.60 BSC.			BALL FOOTPRINT
MD	10			ROW MATRIX SIZE D DIRECTION
ME	8			ROW MATRIX SIZE E DIRECTION
N	80			TOTAL BALL COUNT
φb	0.35	---	0.45	BALL DIAMETER
e	0.80 BSC.			BALL PITCH
SD / SE	0.40 BSC.			SOLDER BALL PLACEMENT
	NONE			DEPOPULATED SOLDER BALLS

NOTES:

- DIMENSIONING AND TOLERANCING PER ASME Y14.5M-1994.
- ALL DIMENSIONS ARE IN MILLIMETERS.
- BALL POSITION DESIGNATION PER JEDEC 95-1, SPP-010 (EXCEPT AS NOTED).
- [e] REPRESENTS THE SOLDER BALL GRID PITCH.
- SYMBOL "MD" IS THE BALL ROW MATRIX SIZE IN THE "D" DIRECTION.  
SYMBOL "ME" IS THE BALL COLUMN MATRIX SIZE IN THE "E" DIRECTION.  
N IS THE TOTAL NUMBER OF SOLDER BALLS.
- [6] DIMENSION "b" IS MEASURED AT THE MAXIMUM BALL DIAMETER IN A PLANE PARALLEL TO DATUM C.
- [7] SD AND SE ARE MEASURED WITH RESPECT TO DATUMS A AND B AND DEFINE THE POSITION OF THE CENTER SOLDER BALL IN THE OUTER ROW.  
WHEN THERE IS AN ODD NUMBER OF SOLDER BALLS IN THE OUTER ROW PARALLEL TO THE D OR E DIMENSION, RESPECTIVELY, SD OR SE = 0.000.  
WHEN THERE IS AN EVEN NUMBER OF SOLDER BALLS IN THE OUTER ROW, SD OR SE = [e/2]
- NOT USED.
- "+" INDICATES THE THEORETICAL CENTER OF DEPOPULATED BALLS.
- [10] A1 CORNER TO BE IDENTIFIED BY CHAMFER, LASER OR INK MARK, METALLIZED MARK INDENTATION OR OTHER MEANS.

Note: BSC is an ANSI standard for Basic Space Centering

3366 \ 16-038.25d1

## Revision Summary

### Revision A0 (July 22, 2004)

Initial release.

### Revision A1 (October 6, 2004)

Add 'BF' parts on Valid Combination table.

### Revision A2 (December 10, 2004)

Remove all in terms of 104MHz speed bin.

Change statement of command during time-out period of sector erase.

Change exit command statement about password program command

Change exit command statement about password protection mode locking bit program command

Change exit command statement about persistentsector protection mode locking bit program command

Change exit command statement about Secured Silicon sector protection bit program command

Change exit command statement about PPB program command

Change exit command statement about All PPB erase command

Change exit command statement about PPB/PPB lock bit status command

Change PPB command table.

Remove note 19 in command table.

Change waveform about boundary crossing.

Remove DC spec output disable status in synchronous read mode.

Change the word from SMPL to PL , from OPBP to OW.

Change the statement PPB Lock Bit Set Command.

Delete V<sub>IO</sub> pin

Added description at "RDY Configuration" in page56

Modified t<sub>AH</sub> in Asynchronous mode to 20ns in page89

### Revision A3 (February 19, 2005)

Change "Secsi" to "Secured Silicon"

Add migration statement.

Modify "Sync Latency", "Asyn Access time" @80MHz

Update "Product Selector Guide" on tACC, tCE, tIACC@80MHz

Modify Table 15( "Wait States for Standard Wait-state Handshaking")

Change "Supply Voltage" to "1.70V to 1.95V for 80MHz parts

Modify "CLK Characterization" table

### Revision A4 (June 24, 2005)

Added information for "Revision 1" for boundary crossing while in Continuous read mode

Removed all references to WS128J 80 MHz and WS064J Industrial grades

### Revision A5 (March 31, 2006)

Updated the Valid Combinations table for the 128 Mb device



**Revision A6 (May 11, 2006)**

Add new OPNs, supporting Industrial temperature

**Colophon**

The products described in this document are designed, developed and manufactured as contemplated for general use, including without limitation, ordinary industrial use, general office use, personal use, and household use, but are not designed, developed and manufactured as contemplated (I) for any use that includes fatal risks or dangers that, unless extremely high safety is secured, could have a serious effect to the public, and could lead directly to death, personal injury, severe physical damage or other loss (i.e., nuclear reaction control in nuclear facility, aircraft flight control, air traffic control, mass transport control, medical life support system, missile launch control in weapon system), or (2) for any use where chance of failure is intolerable (i.e., submersible repeater and artificial satellite). Please note that Spansion will not be liable to you and/or any third party for any claims or damages arising in connection with above-mentioned uses of the products. Any semiconductor device has an inherent chance of failure. You must protect against injury, damage or loss from such failures by incorporating safety design measures into your facility and equipment such as redundancy, fire protection, and prevention of over-current levels and other abnormal operating conditions. If any products described in this document represent goods or technologies subject to certain restrictions on export under the Foreign Exchange and Foreign Trade Law of Japan, the US Export Administration Regulations or the applicable laws of any other country, the prior authorization by the respective government entity will be required for export of those products.

**Trademarks and Notice**

The contents of this document are subject to change without notice. This document may contain information on a Spansion product under development by Spansion. Spansion reserves the right to change or discontinue work on any product without notice. The information in this document is provided as is without warranty or guarantee of any kind as to its accuracy, completeness, operability, fitness for particular purpose, merchantability, non-infringement of third-party rights, or any other warranty, express, implied, or statutory. Spansion assumes no liability for any damages of any kind arising out of the use of the information in this document.

Copyright © 2005-2006 Spansion LLC. All Rights Reserved. Spansion, the Spansion logo, MirrorBit, ORNAND, and combinations thereof are trademarks of Spansion LLC. Other names are for informational purposes only and may be trademarks of their respective owners.