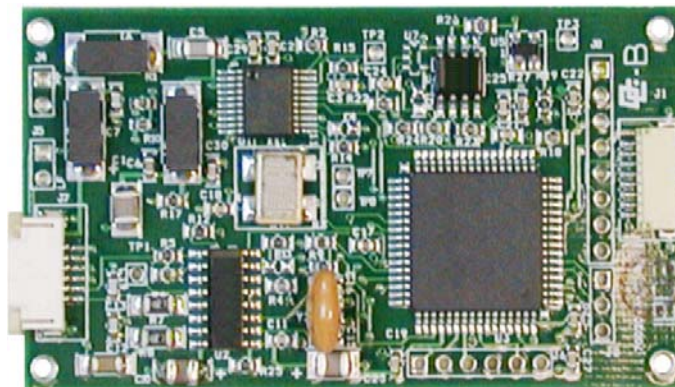

S4100 Multi-Function Reader Module Data Sheet

FEATURES:

- **USART** for I/O Communication
- **Three General Purpose I/O lines**
- **Dual Frequency Operation**
 - 134.4KHz
 - 13.56 MHz
- **Multi-Protocol**
 - TI Rfid LF Products
 - TI Rfid HF Tag-It
 - ISO 15693
 - ISO 14443 A/B
- **Custom Firmware Downloadable**
- **Scalability/Modular Architecture**
- **Power On-Reset Operation**
- **Firmware Upgradable**

Figure 1. S4100 Multi-Function Reader Module
APPLICATIONS:

- | | |
|----------------------------------|----------------------------|
| • Access Control | • Printers |
| • Vending Machines | • Wireless Payments |
| • Point of Sale Terminals | • Handheld Devices |

DESCRIPTION

Texas Instruments' Rfid S4100 Multi-Function Reader communicates with transponders and vicinity/proximity cards compliant with ISO/IEC 14443 A/B and ISO/IEC 15693. It also supports Texas Instruments' Low Frequency DST, Read-Only, and Read-Write Transponders at 134.2kHz, along with Tag-it High Frequency Transponders at 13.56MHz. This is accomplished through dedicated RF Analog Front End (AFE) sections controlled by a high-performance 8-bit Advanced RISC microcontroller with a Harvard architecture, onboard FLASH, EEPROM, and SRAM. The power and flexibility of this platform offer a scalable

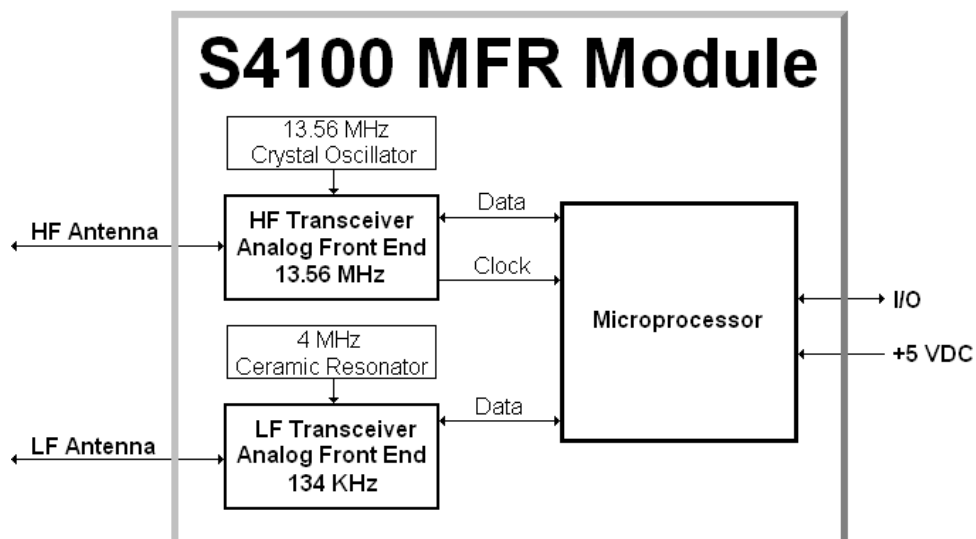
Figure 2. S4100 MFR Block Diagram

solution that can be fitted to a broad range of applications.

The modular firmware architecture makes it easy to produce and download custom firmware to the unit, and further simplifies integration into

new or existing products.

With support for a multitude of contactless technologies, this module is ideal for any contactless application, and makes transitioning to new technologies painless and transparent.

S4100 MULTI-FUNCTION READER MODULE

11-06-22-715 10/2003

SPECIFICATIONS

Attributes

Part Number	RF-MGR-MNMN-N0
Operating Frequency (HF)	13.56 MHz
Operating Frequency (LF)	134.2 kHz
Supported Transponders (HF)	TI Tag-it™ inlays and transponders ISO 15693 compliant inlays and transponders ISO 14443 Type A/B compliant inlays and transponders
Supported Transponders (LF)	TI LF transponders (DST, R/W & R/O)
Supported ISO Standards	ISO 15693 ISO 14443 Type A & B
Transmitter Power (HF)	200 mW
Transmitter Peak-Current (LF)	1.1 Amps Peak
Antenna Impedance (HF)	50 Ohms @ 13.56 MHz
Antenna Impedance (LF)	440 μ H (Approximately)
Antenna Connection	Independent on-board LF & HF Connections
User Interface response	Three General Purpose Inputs/Outputs
Communication Interface	USART with up to 38.4 kbps data rate
Synchronization	Protocol synchronization via host
Approximate Dimensions:	PWB: 2.75" x 1.5" x 0.4" (69 mm x 38 mm x 10 mm)
Approximate Weight	Module: 0.43 Oz (12.2 g)

Absolute Maximum Ratings*

Parameter	Symbol	Value		Units
		Min	Max	
Supply Voltage	V _{cc}	+4.5	+5.5	Volts
Operating Temperature		-20	+70	°C
Storage Temperature		-45	+85	°C
Soldering Temperature**			260	°C
Soldering Time**			5	Sec

DC Electrical Parameters

Parameter	Symbol	Condition	Value			Units
			Min	Typ	Max	
Supply Voltage	V _{cc}		+4.75	5.0	+5.25	Volts
Power On Reset	POR	Reset μ C	+4.25	+4.38	+4.5	Volts

Current Parameters

Parameter	Symbol	Value			Units
		Min	Typ	Max	
Receive Current		30	60	100	mA
LF Transmit Current		95	140	200	mA
HF Transmit Current		75	120	180	mA

* Stresses beyond Absolute Maximum Ratings may cause permanent damage to the device. Exposure to Absolute Maximum Ratings for extended periods may affect device reliability. As with all semiconductor products, proper measures with respect to ESD should be taken.

** Recommended solder: Kester 245 (SN63PB37), Recommended flux: Kester 951 (no clean flux)

CONNECTOR PIN-OUTS AND INTERFACE

Connector J1:

Connector Pins	Input / Output	Signal Name	Connected to	Interface, Sink / Source Current*
8	Input	RX Data	J8 pin 8	Isink_max = 20 mA at 5V
7	Output	TX Data	J8 pin 7	Isource_max = 20 mA at 5V
6	GP I/O	OUT 1	J8 pin 6, J7 pin 3	Isource_max = 20 mA at 5V
5	No Connection	No Connection	J8 pin 5	
4	GP I/O	OUT 2	J8 pin 4, J7 pin 4	Isource_max = 20 mA at 5V
3	GP I/O	OUT 3	J8 pin 3	Isource_max = 20 mA at 5V
2	Ground	Ground	J8 pin 2	System Ground
1	Input	Vcc	J8 pin 1	Regulated Power Input

Connector: Oupiin 4472-8TD1

Mating Connector: Oupiin P/N 4472-1X8H (Housing), 4472-PIN-T (Pin)

Connector J8:

Connector Pins	Input / Output	Signal Name	Connected to	Interface, Sink / Source Current*
1	Input	Vcc	J1 pin 1	Regulated Power Input
2	Ground	Ground	J1 pin 2	System Ground
3	GP I/O	OUT 3	J1 pin 3	Isource_max = 20 mA at 5V
4	GP I/O	OUT 2	J1 pin 4, J7 pin 4	Isource_max = 20 mA at 5V
5	No Connection	No Connection	J1 pin 5	
6	GP I/O	OUT 1	J1 pin 6, J7 pin 3	Isource_max = 20 mA at 5V
7	Output	TX Data	J1 pin 7	Isource_max = 20 mA at 5V
8	Input	RX Data	J1 pin 8	Isink_max = 20 mA at 5V

Connector Type: Header 8 pin 100 mil center

* Connectors J1 and J8 are connected in parallel. If using both connectors, please observe maximum current limits.

Connector J4:

Connector Pins	Input / Output	Signal Name	Connected to	Notes
1	Ground	HF Antenna Ground	J7 pin 1	
2	Output	HF Antenna Output	J7 pin 2	50 Ω

Connector Type: Header 8 pin 100 mil center

Connector J5:

Connector Pins	Input / Output	Signal Name	Connected to	Notes
1	Output	LF Ant High	J7 pin 6	
2	Output	LF Ant Low	J7 pin 5	

Connector Type: Header 2 pin 100 mil center

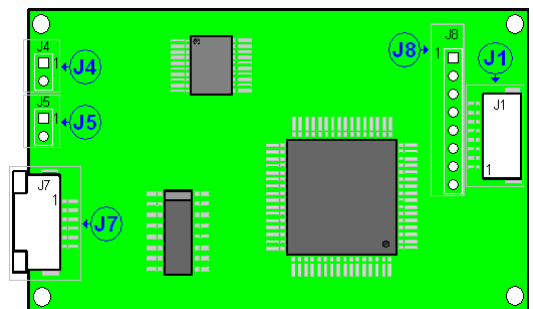

Figure 3. Connector Locations

Connector J7:

Connector Pins	Input / Output	Signal Name	Connected to	Interface, Sink / Source Current
1	Ground	HF Antenna Ground	J4 pin 1	
2	Output	HF Antenna Output	J4 pin 2	50 Ω
3	GP I/O	OUT 1	J1 pin 6, J8 pin 6	Isource_max = 20 mA at 5V
4	GP I/O	OUT 2	J1 pin 4, J8 pin 4	Isource_max = 20 mA at 5V
5	Output	LF Ant Low	J5 pin 2	400 to 700 uH, 440 uH typical between LF Ant 1 and LF Ant 2
6	Output	LF Ant High	J5 pin 1	

Connector: Molex P/N 52207-0690

S4100 MULTI-FUNCTION READER MODULE

11-06-22-715 10/2003

INPUT/OUTPUT INTERFACE

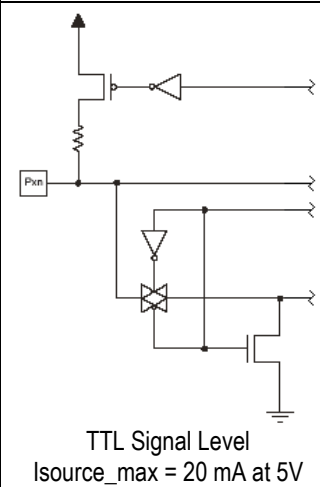
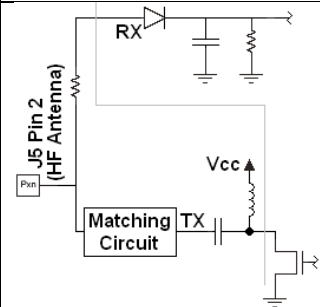
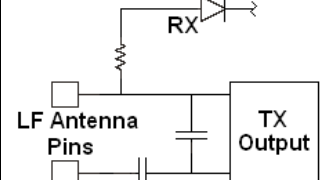
Signal Name	Input / Output	Location	Signal Definition	Interface Circuitry	Max Values*
Vcc	Input	J1 pin 1, J8 pin 1	Input voltage from low-noise regulated power supply.		5.5 V
Ground	Ground	J1 pin 2, J8 pin 2	Ground		
OUT 3	GP I/O	J1 pin 3, J8 pin 3	A low to high transition of this signal line indicates a successful read of a LF transponder.	 <p>TTL Signal Level Isource_max = 20 mA at 5V</p>	5.5 V
OUT 2	GP I/O	J1 pin 4, J7 pin 4, J8 pin 4	A low to high transition of this signal line indicates a successful read of a HF transponder.		5.5 V
OUT 1	GP I/O	J1 pin 6, J7 pin 3, J8 pin 6	A low to high transition of this signal line indicates a successful read of a LF or HF transponder.		5.5 V
TX Data	Output	J1 pin 7, J8 pin 7	Transmit serial data (DCE) to application communications interface. Max data rate is 38.4 kbps.		5.5 V
RX Data	Input	J1 pin 8, J8 pin 8	Receive serial data (DCE) from application communications interface. Max data rate is 38.4 kbps.		5.5 V
HF Antenna Ground	Ground	J4 pin 1, J7 pin 1	Only J4 pin 1 should be used for antenna ground.		5.5 V
HF Antenna Output	Output	J4 pin 2, J7 pin 2	Output to matched 50 Ω HF antenna.		5.5 V
LF Ant High	Output	J5 pin 1, J7 pin 6	LF Antenna Coil Balanced Output - Neither leg should be grounded.		5.5 V
LF Ant Low	Output	J5 Pin 2, J7 pin 5			5.5 V

* Externally applied voltages from pin to ground cannot exceed these values.

MFR READER SYSTEM OVERVIEW

A complete reader system employing the S4100 MFR module consists of the module, an HF (13.56 MHz) section and/or an LF (134.2 kHz) section, an I/O section, and a power supply. Communication with the circuit is achieved by means of a three wire serial link (USART). The microprocessor interface provides on-chip data encoding and recovery, thereby minimizing software design efforts on the part of the user.

The S4100 allows access to the full feature set and onboard data storage of each contactless technology using high-level and low-level commands available through the onboard USART, or directly coded into application-specific firmware loaded into the onboard FLASH. The S4100 provides a boot loader that allows standard or customized firmware to be downloaded via the onboard USART. The ability to execute application-specific firmware onboard the S4100 offers a mechanism for maximizing RF processing speed while minimizing the total cost of new contactless applications.

The HF and LF Analog Front Ends (AFE) produce the necessary RF transmit signals for each technology as driven by the onboard microcontroller. The AFEs also contain the receiver function to filter and demodulate transponder response signals for further decoding by the microcontroller. The S4100 provides the ability to read multiple tokens across multiple technologies by polling each technology individually and performing the anticollision/arbitration required.

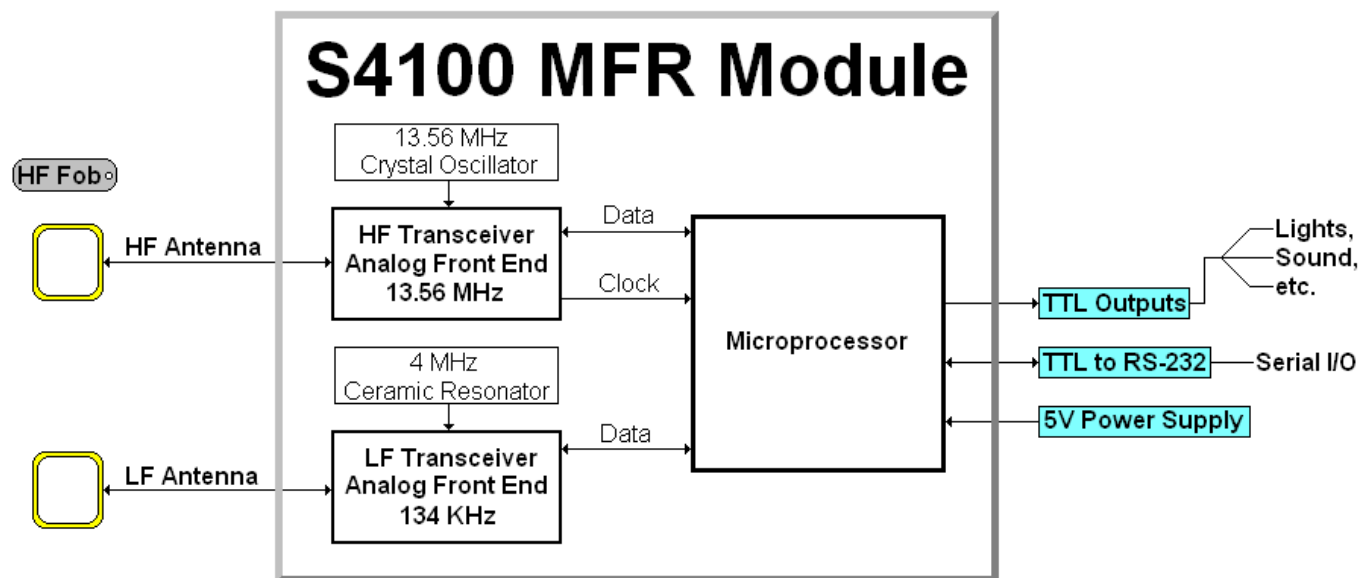

Figure 4. A Complete System Diagram Which includes the S4100 Module.

S4100 MULTI-FUNCTION READER MODULE

11-06-22-715 10/2003

13.56 MHz OPERATION

The 13.56MHz AFE transmitter consists of low impedance MOSFET with a matching network optimized to drive a 50Ω antenna resonating at 13.56MHz. The receiver section is also coupled into this network, detecting the token's load-modulated response. The board matching network transforms the antenna's nominal 50Ω characteristic impedance to the proper load impedance required for the AFE. The output of the HF AFE is single-ended with one side connected to ground. The antenna should be connected using a coaxial connection.

Depending upon the protocol used, the transmitted carrier is modulated as needed for that transponder (10% or 100% modulation), then held at full power in order to detect the load-modulated response. This response is then demodulated, filtered, and prepared (via configurable gain and demodulation sections) for final decoding by the microcontroller.

The HF Section of the S4100 MFR module offers a path for the development of a broad range of 13.56 MHz RFID readers, providing the receive/transmit functions required to communicate with a variety of transponders operating in the 13.56 MHz ISM band.

The transmitter provides a nominal 200 mW of RF power to a matched 50 ohm load.

Using a 1.5" diameter antenna and TI's ISO 15693 compliant rectangular inlay, read ranges are typically equal to or greater than 4". Using the same antenna with TI's ISO 14443 Key Fob inlay, read ranges are typically equal to or greater than 1.5". Using larger antennas may significantly increase these read ranges.

134.2 kHz OPERATION

The 134.2kHz AFE consists of a bridge driver for carrier transmission and a high-gain receiver section for detecting the transponder response. These sections are coupled together and designed for optimal resonance with a 440uH coil antenna attached to the two-pin LF antenna port. Although the full bridge is protected against a direct or resistive short to GROUND, it is designed to drive the antenna differentially. Thus, the two-port coil antenna must be isolated from ground for proper operation.

The full bridge drives the antenna current at the 134.2kHz carrier frequency during the charge phase and the active time of the write phase. When the full bridge is not active, the two driver outputs switch to GROUND. With one driver port coupled to the connected antenna through the resonance capacitor, the circuit produced by the grounded outputs allows the antenna to resonate for reception of the transponder signal (uplink).

After an initial gain stage, the received transponder uplink signal is band-pass filtered from 65kHz to 260kHz to capture the FSK uplink nominal frequencies of 134.2kHz and 123.2kHz and reject out-of-band noise. The received signal is then limited for decoding.

The LF antenna consists of an antenna coil connected to connector J5 pins 1 and 2. The coil inductance can vary anywhere from 400 μH to 700 μH, with 440 μH being optimum.

Using a coil antenna approximately 2" in diameter and TI's DST Key Fob, read ranges are typically greater than or equal to 4 inches.

TYPICAL APPLICATION

Figure 7 is a schematic showing example circuitry for typical I/O schemes. Circuitry for RS-232 serial communications is provided, as well as that for user feedback elements such as LEDs and audio transducers. The connections available at connector J1 are also available from the header connector J8.

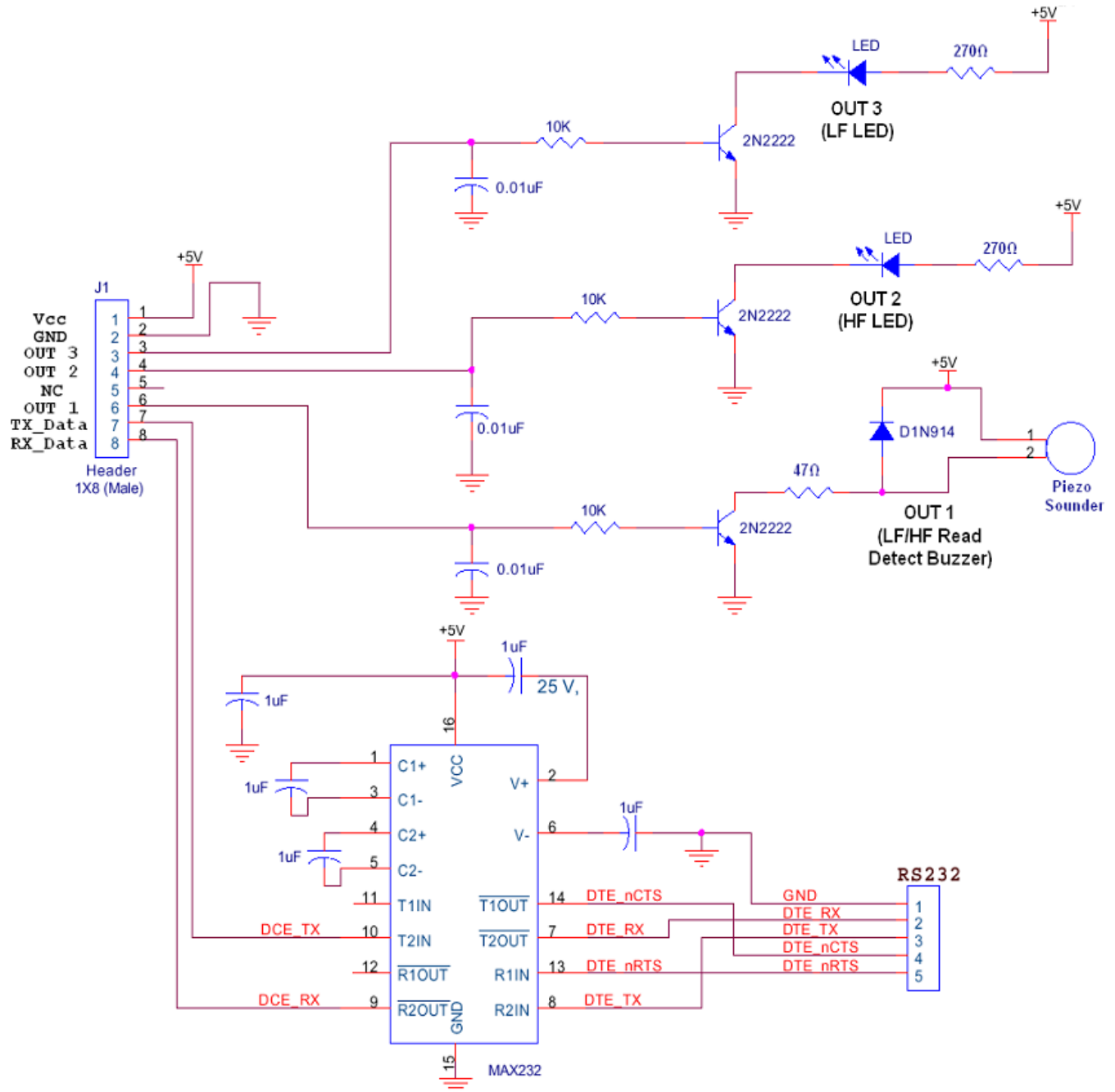

Figure 7. Interface Circuitry.

S4100 MULTI-FUNCTION READER MODULE

11-06-22-715 10/2003

MECHANICAL PROPERTIES

Figure 8 describes board dimensions and mounting hole locations. The module is designed to be easily mounted to a motherboard, communicating through the header pins, but can also be inserted into existing equipment using connectors J1 and J7 for connectivity.

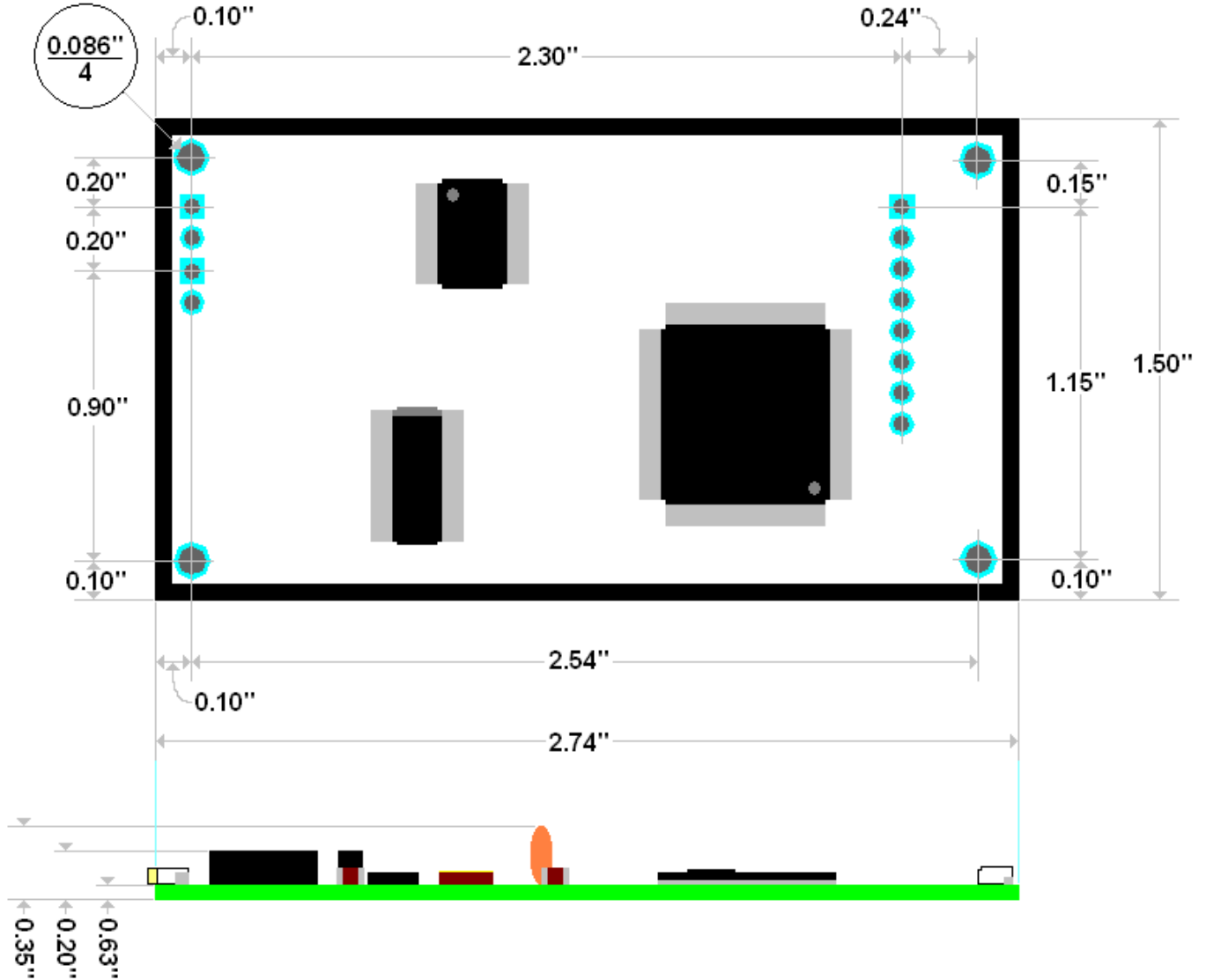

Figure 8. MFR Module Board Dimensions.

Texas Instruments (TI) reserves the right to make changes to its products or services or to discontinue any product or service at any time without notice. TI provides customer assistance in various technical areas, but does not have full access to data concerning the use and applications of customer's products. Therefore, TI assumes no liability and is not responsible for customer applications or product or software design or performance relating to systems or applications incorporating TI products. In addition, TI assumes no liability and is not responsible for infringement of patents and/or any other intellectual or industrial property rights of third parties, which may result from assistance provided by TI. TI products are not designed, intended, authorized or warranted to be suitable for life support applications or any other life critical applications which could involve potential risk of death, personal injury or severe property or environmental damage.