

INTRODUCTION

The S5F429PX03 is an interline transfer CCD area image sensor developed for PAL 1/4 inch optical format video cameras, surveillance cameras, object detectors and image pattern recognizers. High sensitivity is achieved through the adoption of Ye, Cy, Mg and G complementary color mosaic filters, on-chip micro lenses and HAD (Hole Accumulated Diode) photosensors. This chip features a field integration read out system and an electronic shutter with variable charge storage time.

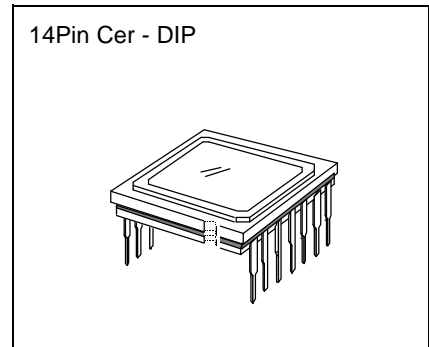

FEATURES

- High Sensitivity
- Optical Size 1/4 inch Format
- No Adjust Substrate Bias
- Ye, Cy, Mg, G On-chip Complementary Color Mosaic Filter
- Low Dark Current
- Horizontal Register 3.3 to 5.0V Drive
- 14pin Ceramic DIP Package
- Field Integration Read Out System
- No DC Bias on Reset Gate

ORDERING INFORMATION

Device	Package	Operating
S5F429PX03-LDB0	14Pin Cer - DIP	-10 °C – +60 °C

STRUCTURE

- Number of Total Pixels: 537(H) × 597(V)
- Number of Effective Pixels: 500(H) × 582(V)
- Chip Size: 4.80mm(H) × 4.04mm(V)
- Unit Pixel Size: 7.30 μm(H) × 4.70 μm(V)
- Optical Blacks & Dummies: Refer to Figure Below
Vertical 1 Line (Even Field Only)

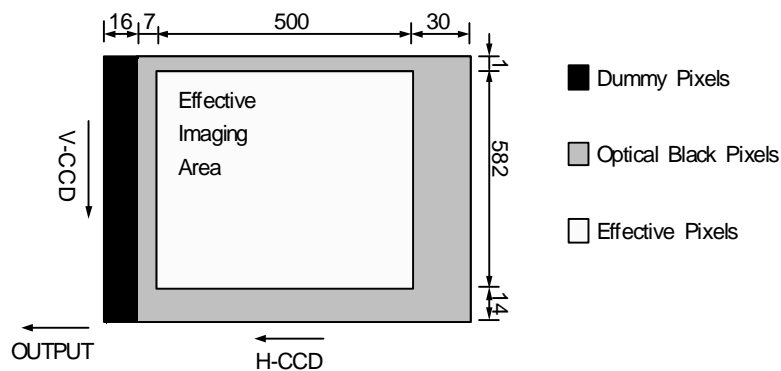

BLOCK DIAGRAM

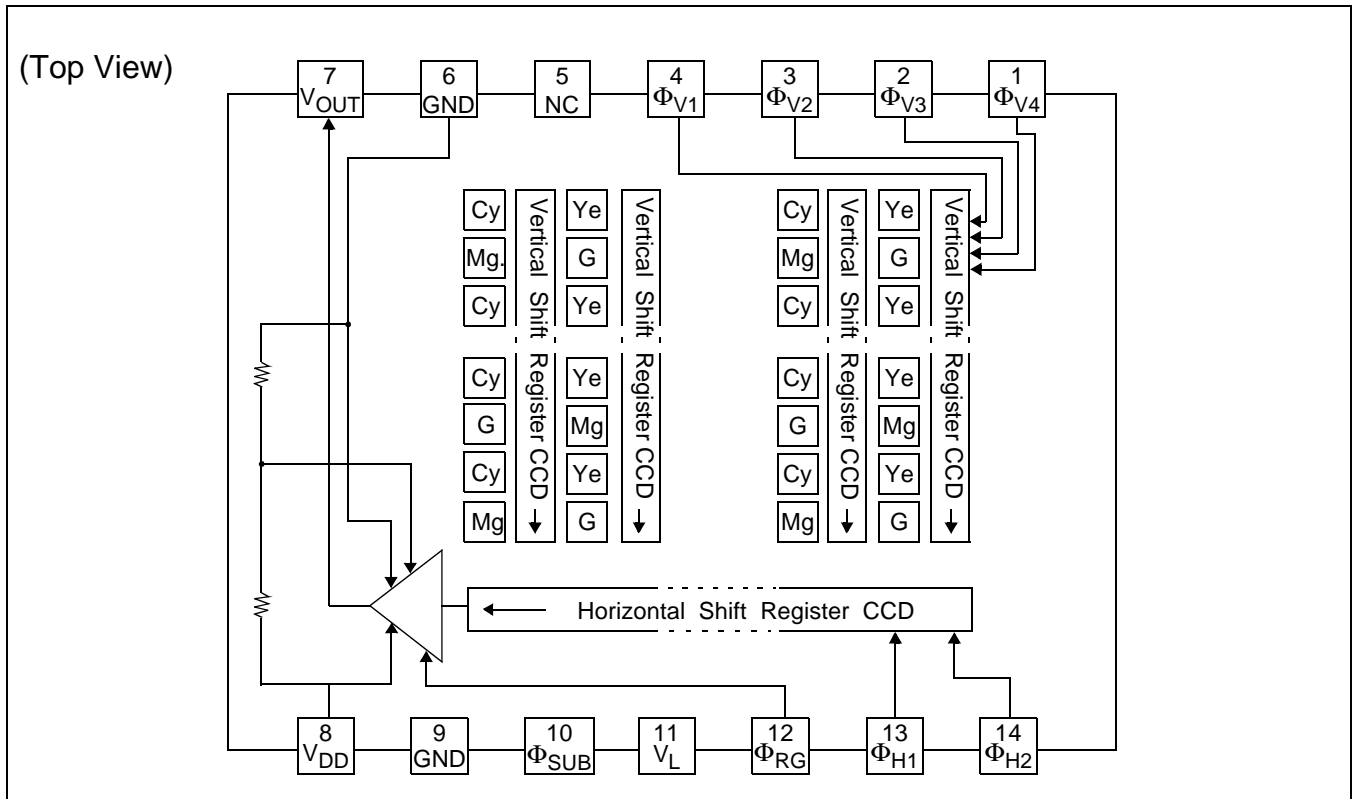

Figure 1. Block Diagram

PIN DESCRIPTION

Table 1. Pin Description

Pin	Symbol	Description	Pin	Symbol	Description
1	Φ_{V4}	Vertical register transfer clock	8	V_{DD}	Output stage drain bias
2	Φ_{V3}	Vertical register transfer clock	9	GND	GND
3	Φ_{V2}	Vertical register transfer clock	10	Φ_{SUB}	Substrate clock
4	Φ_{V1}	Vertical register transfer clock	11	V_L	Protection transistor bias
5	NC	No connection	12	Φ_{RG}	Reset gate clock
6	GND	Ground	13	Φ_{H1}	Horizontal register transfer clock
7	V_{OUT}	Signal output	14	Φ_{H2}	Horizontal register transfer clock

ABSOLUTE MAXIMUM RATINGS (NOTE)**Table 2. Absolute Maximum Ratings**

Characteristics	Symbols	Min.	Max.	Unit
Substrate voltage	SUB - GND	-0.3	40	V
	V_{DD}, V_{OUT} - SUB	-40	10	V
Vertical clock input voltage	Φ_{V1}, Φ_{V3} - GND	-0.3	30	V
	Φ_{V2}, Φ_{V4} - GND	-0.3	17	V
	Φ_{V1}, Φ_{V3} - V_L	-0.3	30	V
	Φ_{V2}, Φ_{V4} - V_L	-0.3	17	V
	$\Phi_{V1}, \Phi_{V2}, \Phi_{V3}, \Phi_{V4}$ - SUB	-40	10	V
Horizontal clock input voltage	Φ_{H1}, Φ_{H2} - V_L	-0.3	7	V
	Φ_{H1}, Φ_{H2} - SUB	-40	7	V
Voltage difference between vertical and horizontal clock input pins	$\Phi_{V1}, \Phi_{V2}, \Phi_{V3}, \Phi_{V4}$		15	V
	Φ_{H1}, Φ_{H2}		17	V
	Φ_{H1}, Φ_{H2} - Φ_{V4}	-17	17	V
Output clock input voltage	Φ_{RG} - GND	-0.3	17	V
	Φ_{RG} - SUB	-40	17	V
Protection circuit bias voltage	V_L - SUB	-40	10	V
Operating temperature	T_{OP}	-10	60	°C
Storage temperature	T_{STG}	-30	80	°C

NOTE: The device can be destroyed, if the applied voltage or temperature is higher than the absolute maximum rating voltage or temperature.

DC CHARACTERISTICS

Table 3. DC Characteristics

Item	Symbol	Min.	Typ.	Max.	Unit
Output stage drain bias	V_{DD}	14.55	15.0	15.45	V
Protection circuit bias voltage	V_L	The lowest vertical clock level			
Output stage drain current	I_{DD}		5		mA

CLOCK VOLTAGE CONDITIONS

Table 4. Clock Voltage Conditions

Item	Symbol	Min.	Typ.	Max.	Unit	Remark
Read-out clock voltage	V_{VH1}, V_{VH3}	14.55	15.0	15.45	V	High level
Vertical transfer clock voltage	$V_{VM1} \sim V_{VM4}$	-0.2	0.0	0.2	V	Middle
	$V_{VL1} \sim V_{VL4}$	-8.0	-7.5	-7.0	V	Low
Horizontal transfer clock voltage	V_{HH1}, V_{HH2}	3.0	5.0	5.25	V	High
	V_{HL1}, V_{HL2}	-0.05	0.0	0.05	V	Low
Charge reset clock voltage	V_{RGH}	4.75	5.0	5.25	V	High
	V_{RGL}	-0.2	0.0	0.2	V	Low
Substrate clock voltage	$V_{\phi SUB}$	21.5	22.5	23.5	V	Shutter

DRIVE CLOCK WAVEFORM CONDITIONS

Read Out Clock Waveform

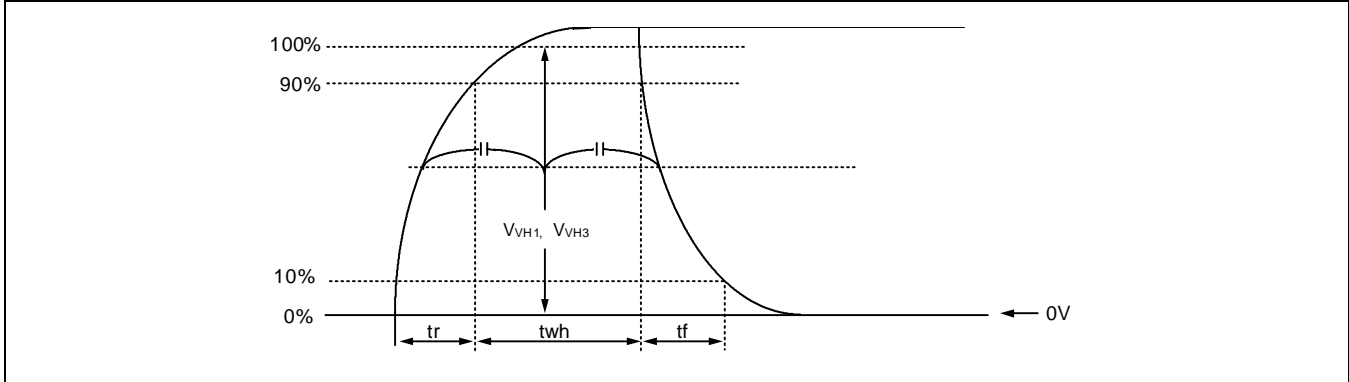

Vertical Transfer Clock Waveform

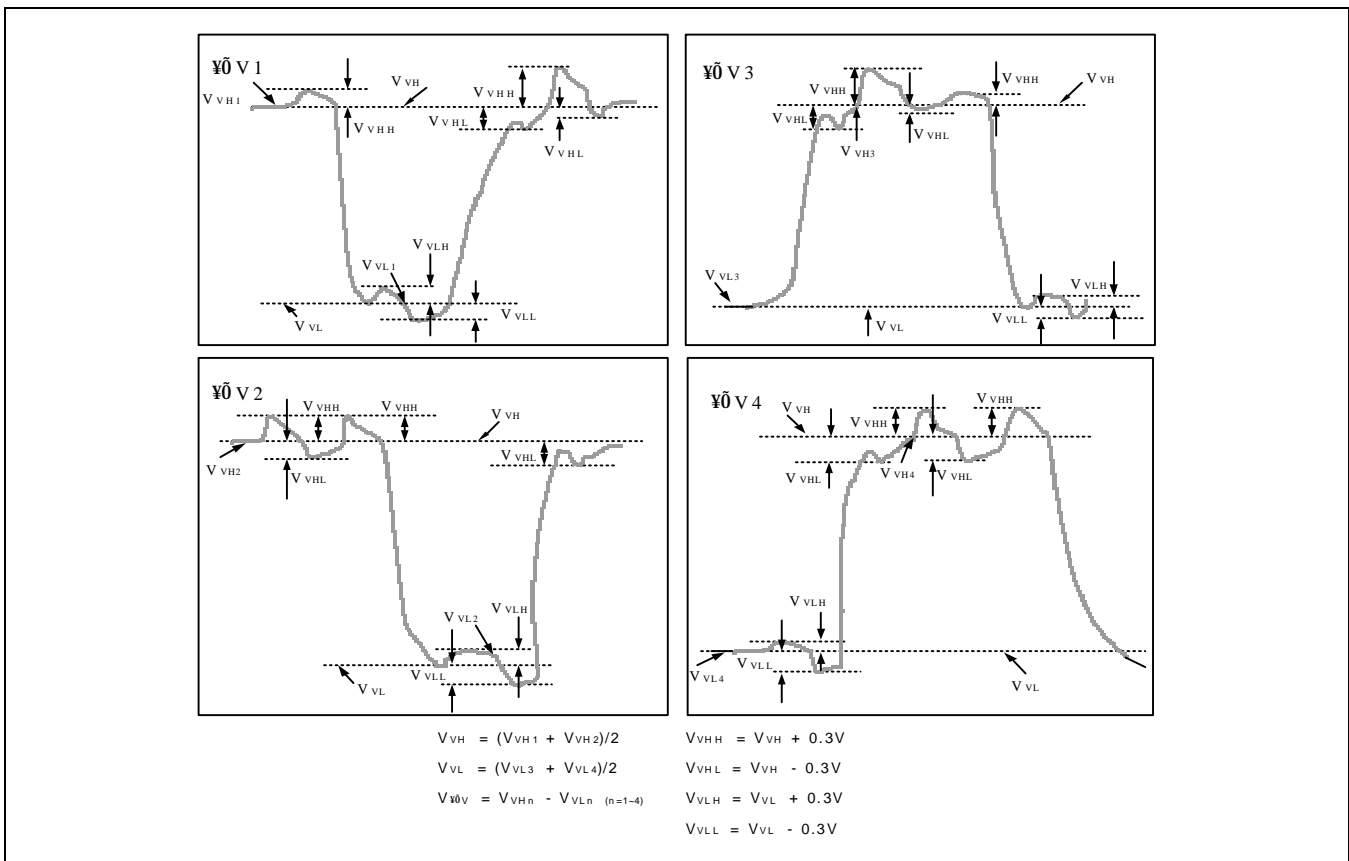

Horizontal Transfer Clock Waveform Diagram

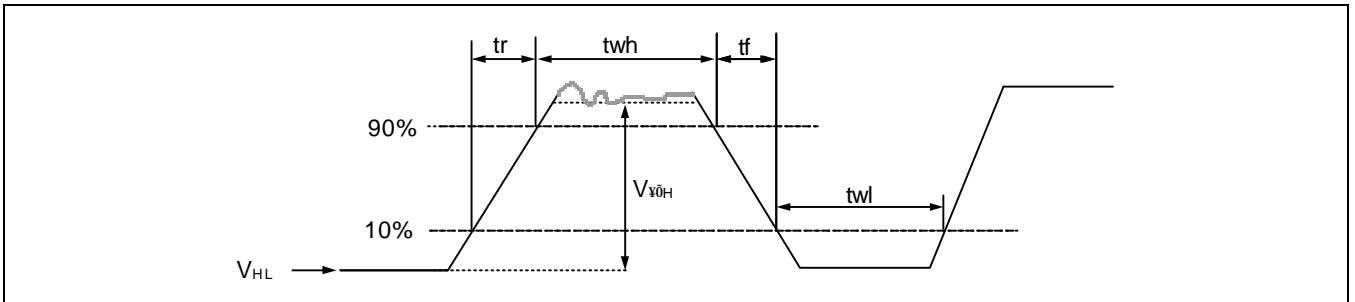

Reset Gate Clock Waveform Diagram

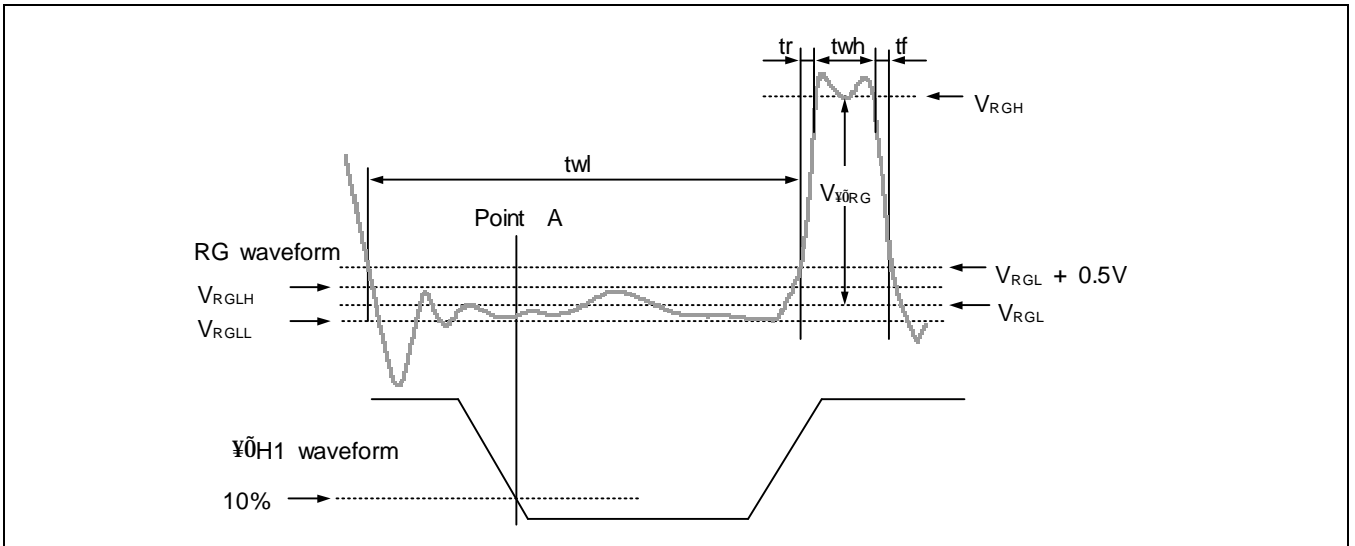

V_{RGLH} is the maximum value and V_{RGLL} is the minimum value of the coupling waveform in the period from Point A in the diagram about to R_G rise

$$V_{RGL} = (V_{RGLH} + V_{RGLL})/2, V_{FRG} = V_{RGH} - V_{RGL}$$

Substrate Clock Waveform

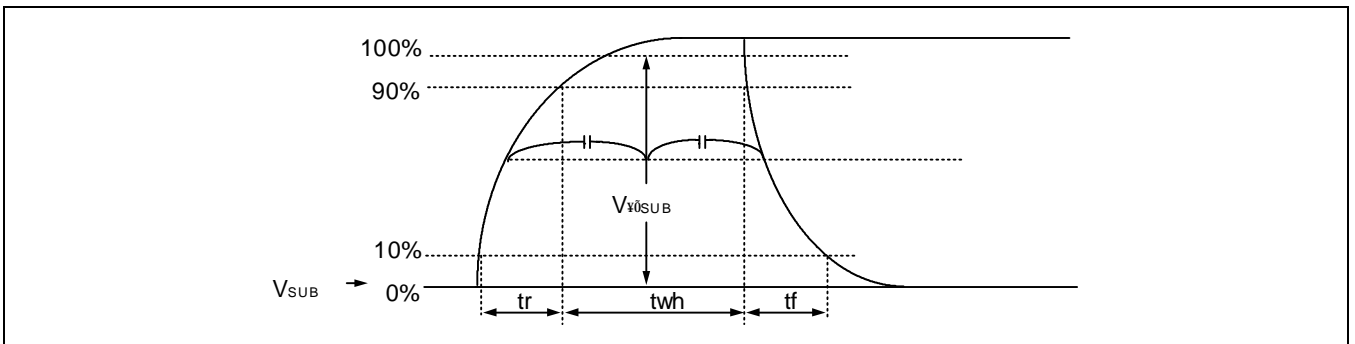

CLOCK EQUIVALENT CIRCUIT CONSTANT

Table 5. Clock Equivalent Circuit Constant

Item	Symbol	twh			twl			tr			tf			Unit
		Min.	Typ.	Max.	Min.	Typ.	Max.	Min.	Typ.	Max.	Min.	Typ.	Max.	
Read-out clock	Φ_{VH}	2.3	2.5						0.1			0.1		μ s
Vertical clock	Φ_{V1}, Φ_{V2} Φ_{V3}, Φ_{V4}										5		250	ns
Horizontal clock	Φ_{H1}	41	46		41	46			6.5	9.5		6.5	9.5	ns
	Φ_{H2}	41	46		41	46			6.5	9.5		6.5	9.5	ns
Reset clock	Φ_{RG}	11	14		76	80			6.0			5.0		ns
Substrate clock	Φ_{SUB}	1.5	2.0							0.5			0.5	μ s

EQUIVALENT CIRCUIT PARAMETERS

Table 6. Equivalent Circuit Parameters

Item	Symbol	Typ.	Unit	Remark
Capacitance between vertical transfer clock and GND	$C_{\Phi V1}, C_{\Phi V3}$	680	pF	
	$C_{\Phi V2}, C_{\Phi V4}$	820	pF	
Capacitance between vertical transfer clocks	$C_{\Phi V12}, C_{\Phi V34}$	180	pF	
	$C_{\Phi V23}, C_{\Phi V41}$	180	pF	
	$C_{\Phi V13}$	60	pF	
	$C_{\Phi V24}$	60	pF	
Capacitance between horizontal transfer clock and GND	$C_{\Phi H1}, C_{\Phi H2}$	30	pF	
Capacitance between horizontal transfer clocks	$C_{\Phi H12}$	30	pF	
Capacitance between substrate clock and GND	$C_{\Phi SUB}$	180	pF	
Vertical transfer clock serial resistor	$R_{\Phi V1} \sim R_{\Phi V4}$	40	Ω	
Vertical transfer clock ground resistor	$R_{\Phi VGND}$	15	Ω	
Horizontal transfer clock serial resistor	$R_{\Phi H1}, R_{\Phi H2}$	10	Ω	
Reset gate clock serial resistor	$R_{\Phi RG}$	100	Ω	

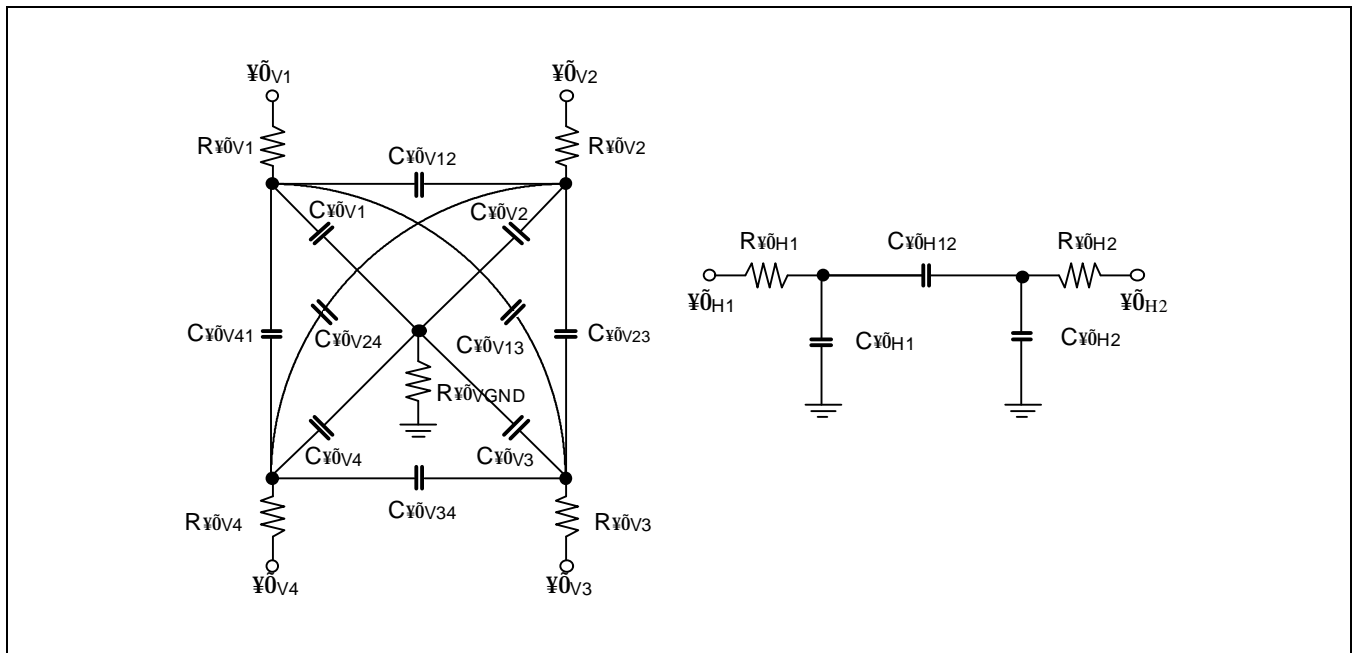

OPERATING CHARACTERISTICS

Device Temperature = 25 °C

Table 7. Operating Characteristics

Item	Symbol	Min.	Typ.	Max.	Unit	Remark
Sensitivity	S	40	45		mV/lux	1
Saturation signal	Y_{SAT}	800			mV	2
Smear	SM		0.007	0.01	%	3
Blooming margin	BM	1,000			times	4
Uniformity	U			20	%	5
Dark signal (NOTE)	D			2	mV	6
Dark shading (NOTE)	ΔD			2	mV	7
Image lag	Y_{LAG}			0.5	%	8
Flicker Y	F_Y			2	%	9
Flicker red, blue	F_{CR}, F_{CB}			5	%	10
Color uniformity	D_{SR}, D_{SB}			10	%	11
Line stripe W, R, G, B	$L_{CW}, L_{CR}, L_{CG}, L_{CB}$			3	%	12

NOTE: Test Temperature = 60 °C

TESTING SYSTEM

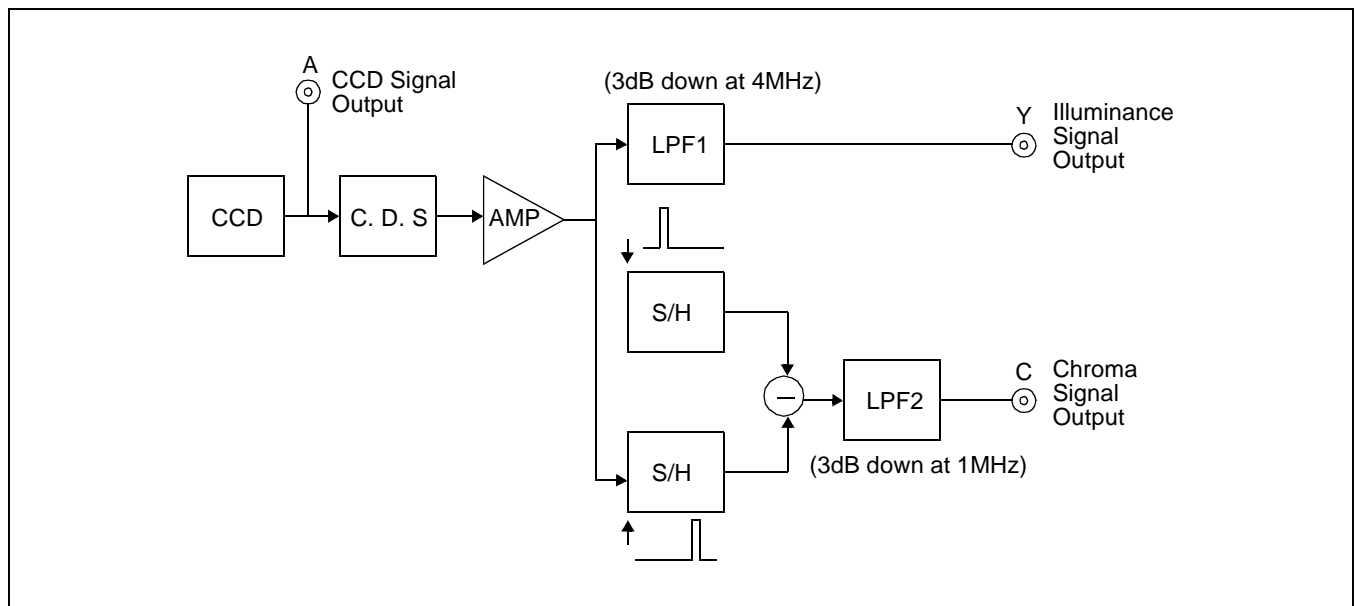

Figure 2. Testing System

TEST CONDITION

1. Use a light source with color temperature of 3,200K hallogen lamp and CM-500S for IR cut filter.
The light source is adjusted in accordance with the average value of Y signals indicated in each item.

COLOR FILTER ARRAY

The color filter array of this image sensor is shown in the right figure. this complementary mosaic CFA is used with the operation of field integration mode, where all of the photosensors are read out during each video field. The signals from two vertically-adjacent photosensor lines, such as line couple A1 or A2 for field A are summed when the signal charges are transferred into the vertical transfer CCD column. The read out line pairing is shifted down by one line for field B.

The sensor output signals through the horizontal register (H-CCD) at line A1 are [G+Cy], [Mg+Ye], [G+CY], [Mg+Ye]. These signals are processed in order to compose Y and C signals. By adding the two adjacent signals at line A1, Y signal is formed as follows

$$Y = \frac{1}{2}[(G + Cy) + (Mg + Ye)] = \frac{1}{2}(2B + 3G + 2R)$$

C signal is composed by subtracting the two adjacent signals at line A1

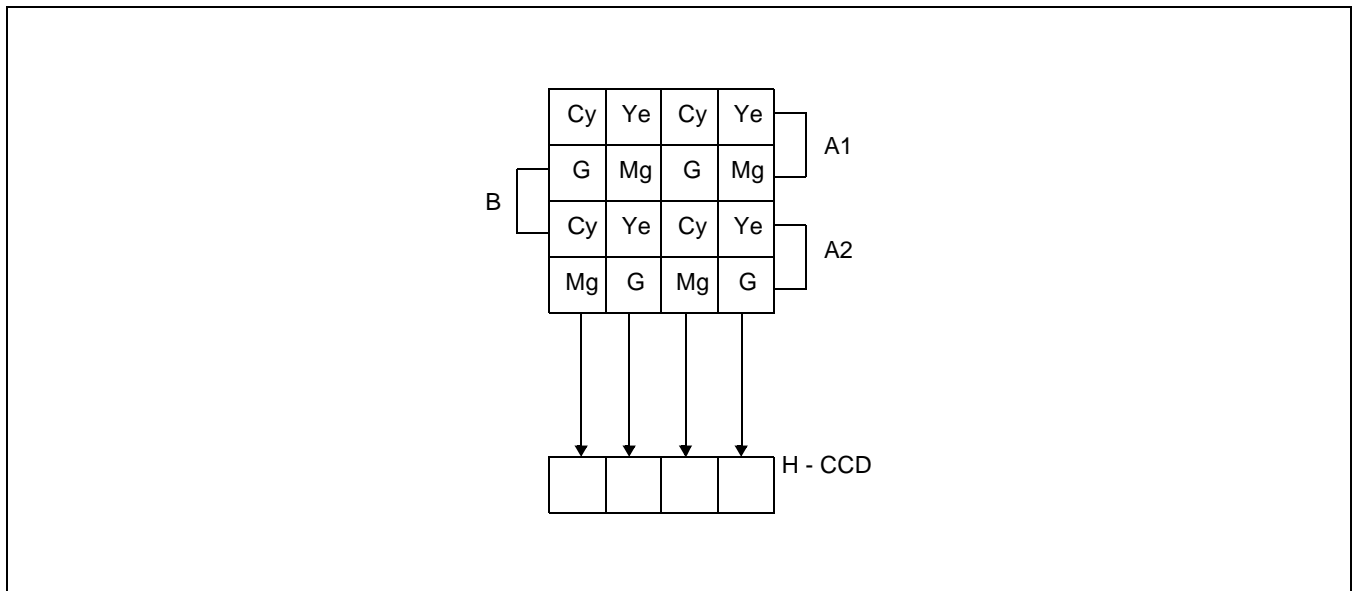

Figure 3. Color Filter Array

$$R-Y = [(Mg + Ye) - (G + Cy)] = (2R - G)$$

Next, the signals through H-CCD at line A2 are [Mg+Cy], [G+Ye], [Mg+Cy], [G+Ye]. Similarly, Y and C signals are composed at line A2 as follows

$$Y = \frac{1}{2}[(G + Ye) + (Mg + Cy)] = \frac{1}{2}(2B + 3G + 2R)$$

$$-(B - Y) = [(G + Ye) - (Mg + Cy)] = -(2B - G)$$

Accordingly, Y signal is balanced in relation to scanning lines, and C signal takes the form of R-Y and -(B-Y) on alternate lines.

It is same for B field.

TEST METHODS

1. Measure the light intensities (L) when the averaged illuminance output value (Y) is the standard illuminance output value, 150mV (Y_A) and when half of 150mV ($1/2 Y_A$).

$$S = \frac{Y_A - \frac{1}{2}Y_A}{L_{Y_A} - L_{\frac{1}{2}Y_A}}$$

2. Adjust the light intensity to 15 times of the value with which Y is Y_A , then measure the averaged illuminance output value ($Y = Y_{SAT}$).

3. Adjust the light intensity to 500 times of the value with which Y is Y_A , then remove the read-out clock and drain the signal in photosensors by the electronic shutter operation in all the respective horizontal blanking times with the other clocks unchanged. Measure the maximum illuminance output value (Y_{SM}).

$$SM = \frac{Y_{SM}}{Y_A} \times \frac{1}{500} \times \frac{1}{10} \times 100(\%)$$

4. Adjust the light intensity to 1,000 times of the value with which Y is Y_A , then inspect whether there is blooming phenomenon or not.

5. Measure the maximum and minimum illuminance output value (Y_{MAX} , Y_{MIN}) when the light intensity is adjusted to make Y to be Y_A .

$$U = \frac{Y_{MAX} - Y_{MIN}}{Y_A} \times 100(\%)$$

6. Measure Y_D with the horizontal idling time transfer level as reference, when the device ambient temperature is 60 °C and all of the light sources are shielded.

7. Follow test method 6, measure the maximum (D_{MAX}) and minimum illuminance output (D_{MIN}).

$$\Delta D = D_{MAX} - D_{MIN}$$

8. Adjust the light intensity of Y signal output value by strobe light to 150mV (Y_A), calculate by below formula with measuring the image lag signal which is generated by below timing diagram.

$$Y_{LAG} = (Y_{lag} / 150) \times 100(\%)$$

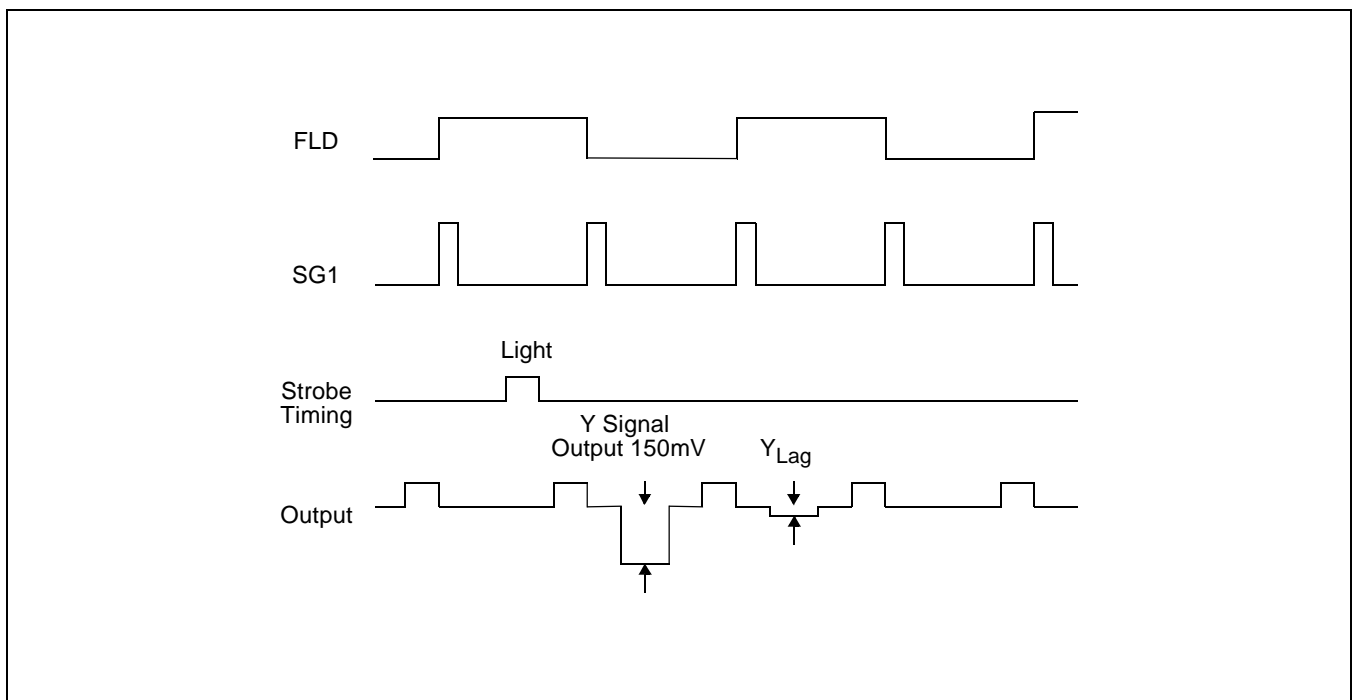

9. Adjust the light intensity of Y signal average value to 150mV (Y_A), calculate by below formula with measuring the signal differences (ΔY_f [mV]) between fields.

$$F_Y = (\Delta Y_f / Y_A) \times 100(\%)$$

10. Adjust the light intensity to make $Y = Y_A$ using red (R) and blue (B) optical filters respectively, measure the differences ($\Delta C_R, \Delta C_B$) between the chroma signal values in even and odd fields and the averaged chroma signal values (C_R, C_B).

$$F_{C_i} = \frac{\Delta C_i}{C_i} \times 100(\%)$$

, where $i = R, B$

11. Adjust the light intensity to make $Y = Y_A$ using red (R) and blue (B) optical filters respectively, measure the minimum ($C_{R,MIN}$ and $C_{B,MIN}$) and maximum ($C_{R,MAX}$ and $C_{B,MAX}$) chroma signal values.

$$DS_i = \frac{C_{i,MAX} - C_{i,MIN}}{Y_i} \times 100(\%)$$

, where $i = R, B$

12. Adjust the light intensity to make $Y = 150\text{mV}(Y_L)$ using white (no filter, W), red (R), green (G) and blue (B) optical filters respectively, measure the illuminance signal difference values ($\Delta Y_{LW}, \Delta Y_{LR}, \Delta Y_{LG}, \Delta Y_{LB}$) between illuminance signal lines of the same field.

$$L_{C_i} = \frac{\Delta Y_{L_i}}{Y_L} \times 100(\%)$$

, where $i = W, R, G, B$

SPECTRAL RESPONSE CHARACTERISTICS

Excluding Light Source Characteristics

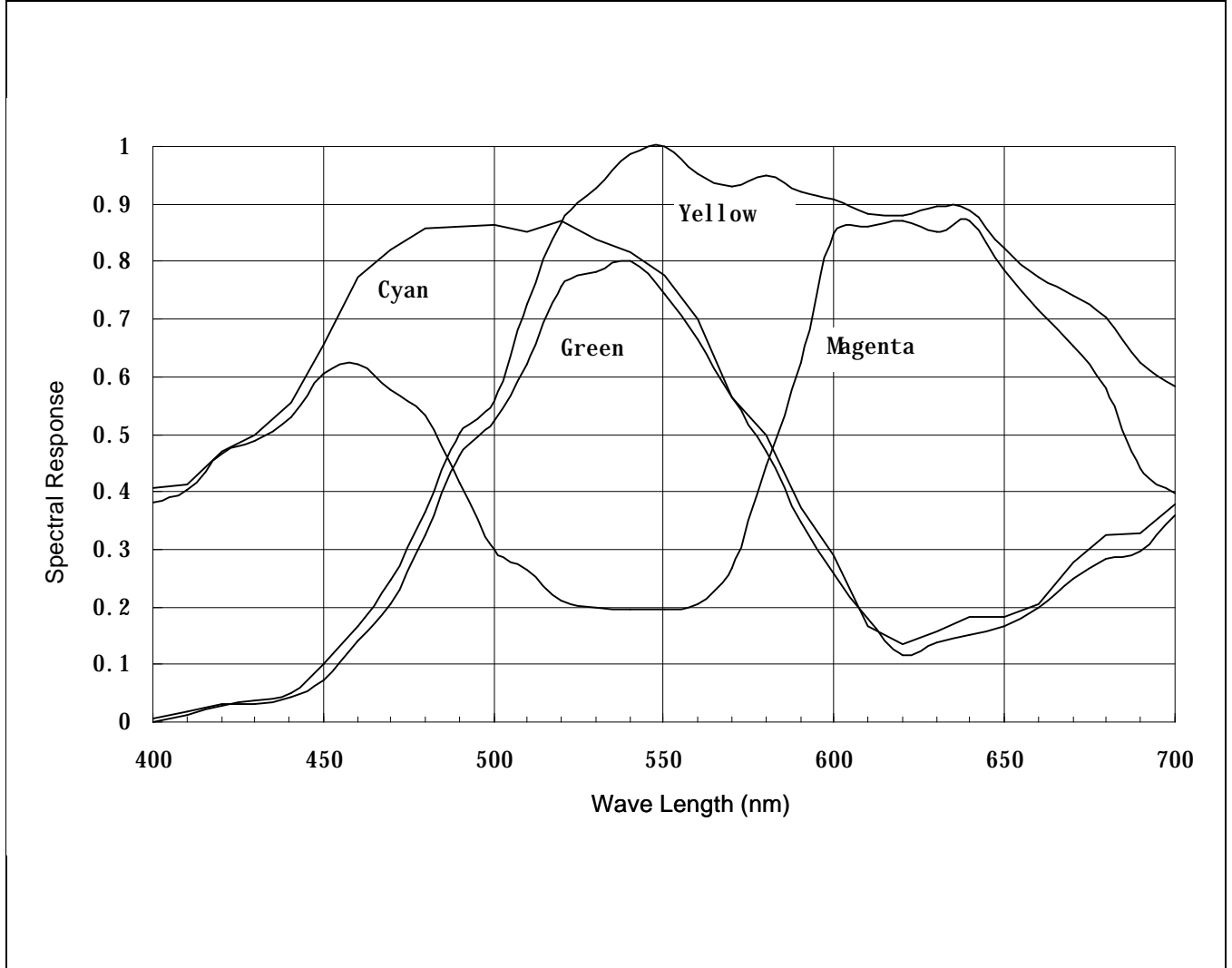

Figure 4. Spectral Response Characteristics

APPLICATION CIRCUITS

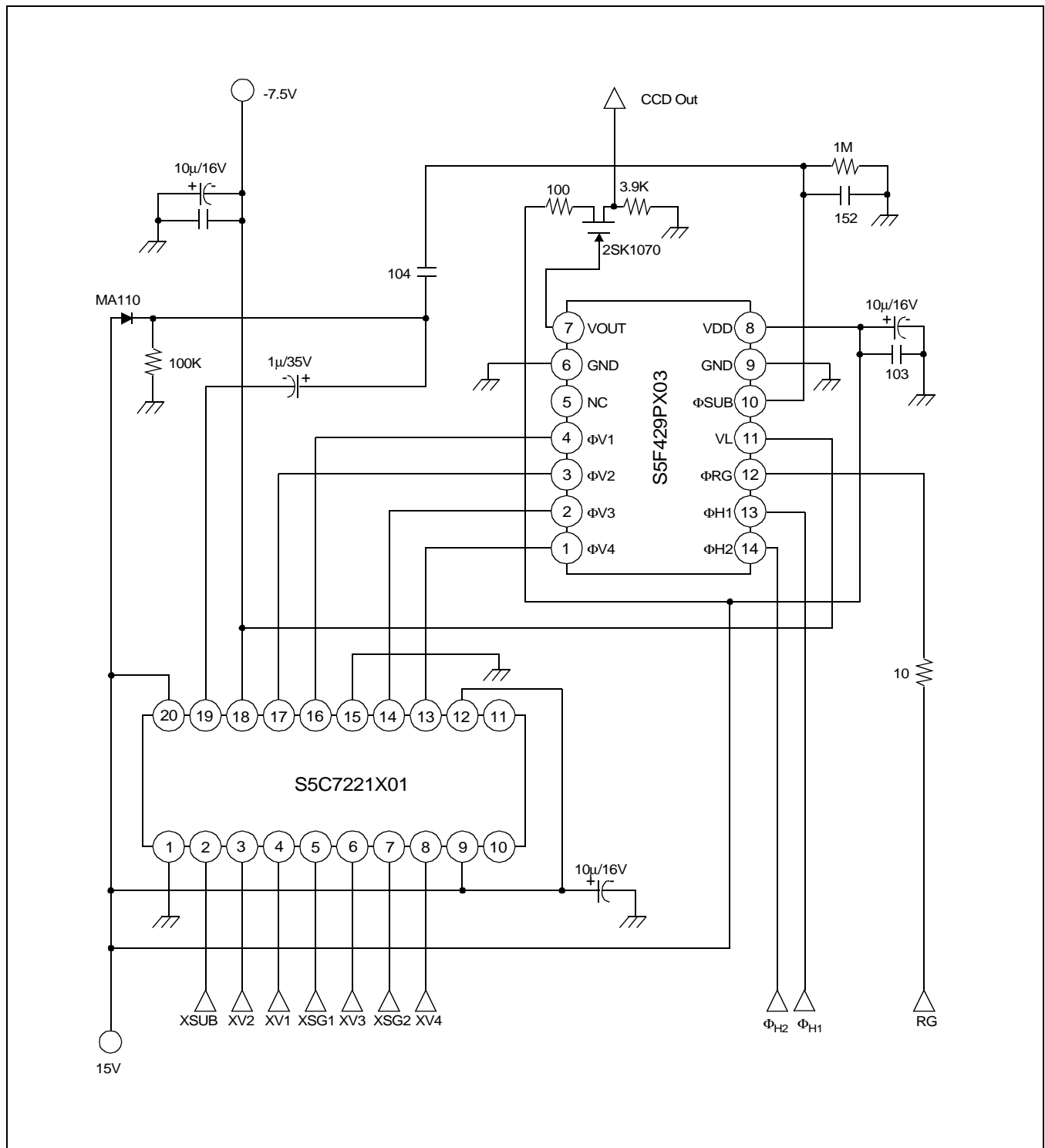

Figure 5. Application Circuits

READ-OUT CLOCK TIMING CHART

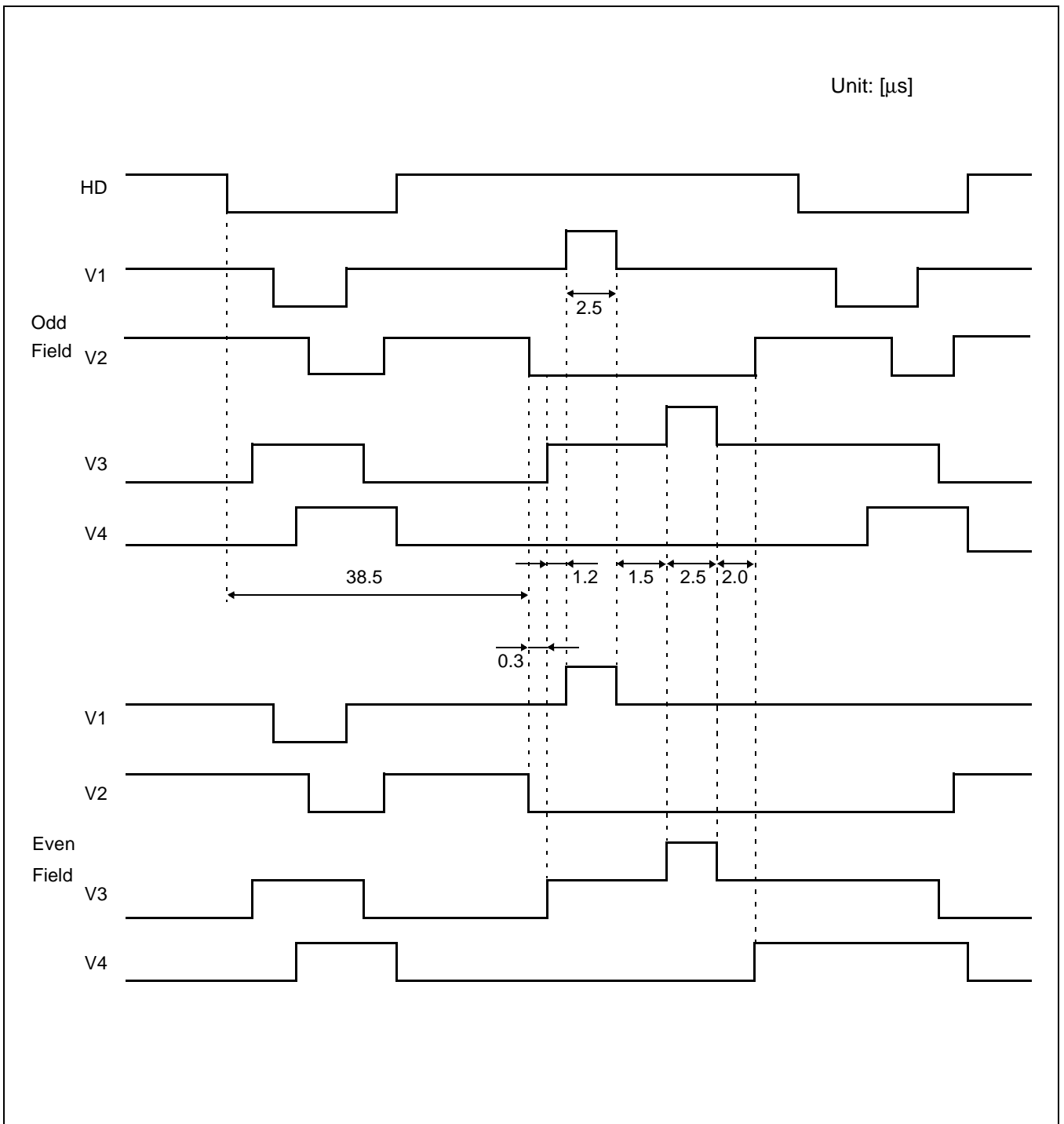

Figure 6. Read-out Clock Timing Chart

CLOCK TIMING CHART (VERTICAL SYNC.)

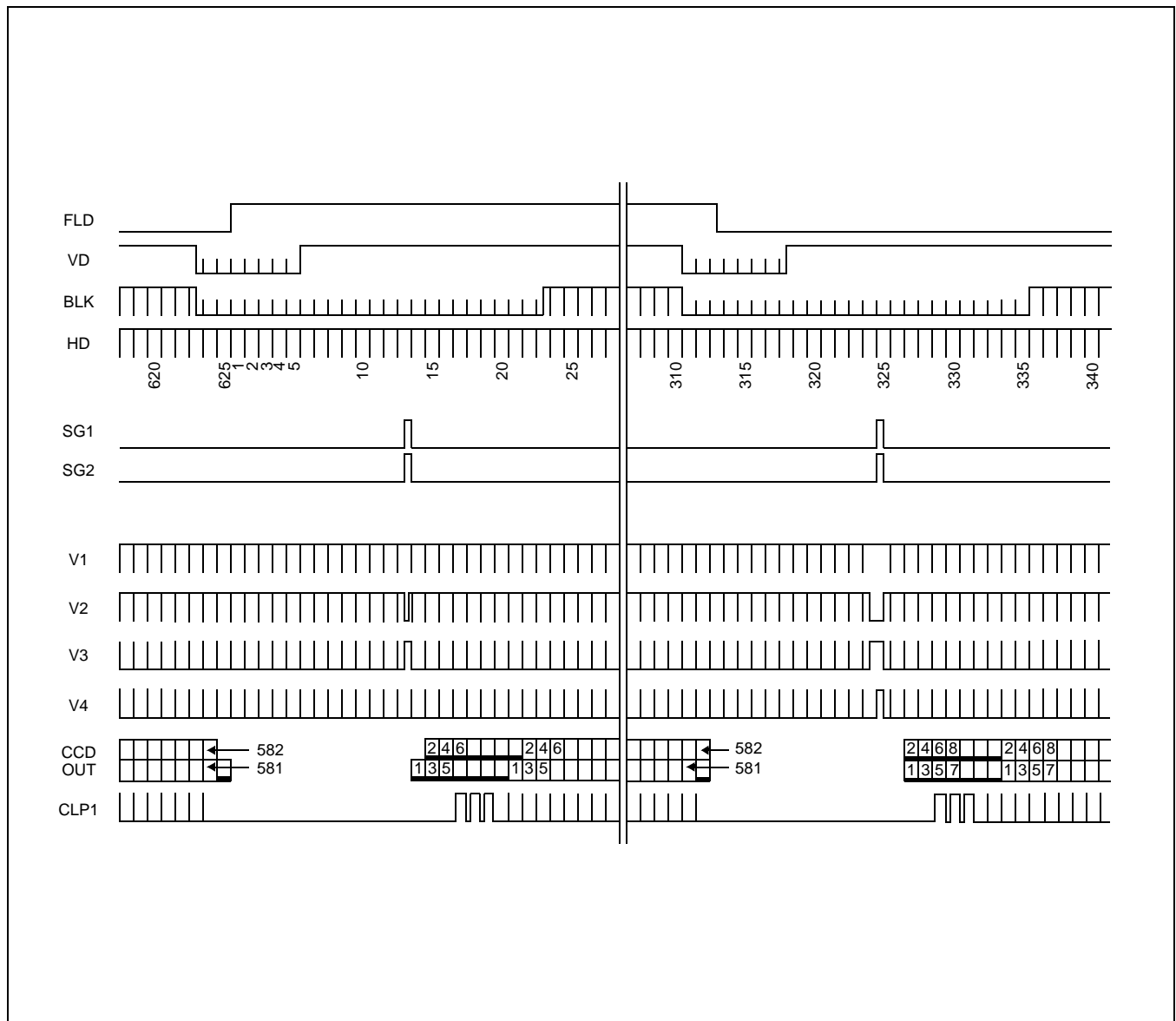

Figure 7. Clock Timing Chart (Vertical Sync.)

CLOCK TIMING CHART (HORIZONTAL SYNC.)

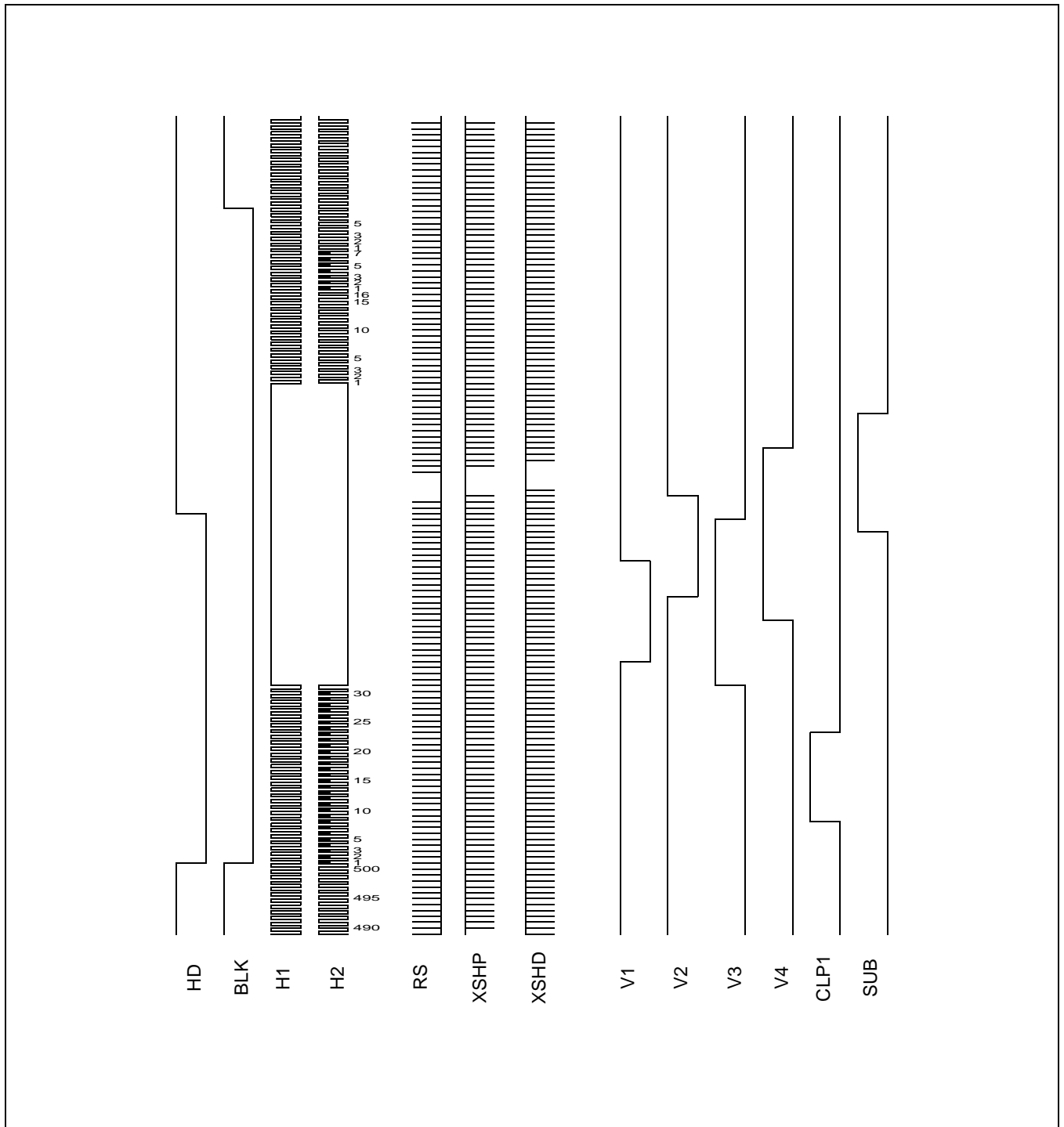

Figure 8. Clock Timing Chart (Horizontal Sync.)

PACKAGE DIMENSIONS

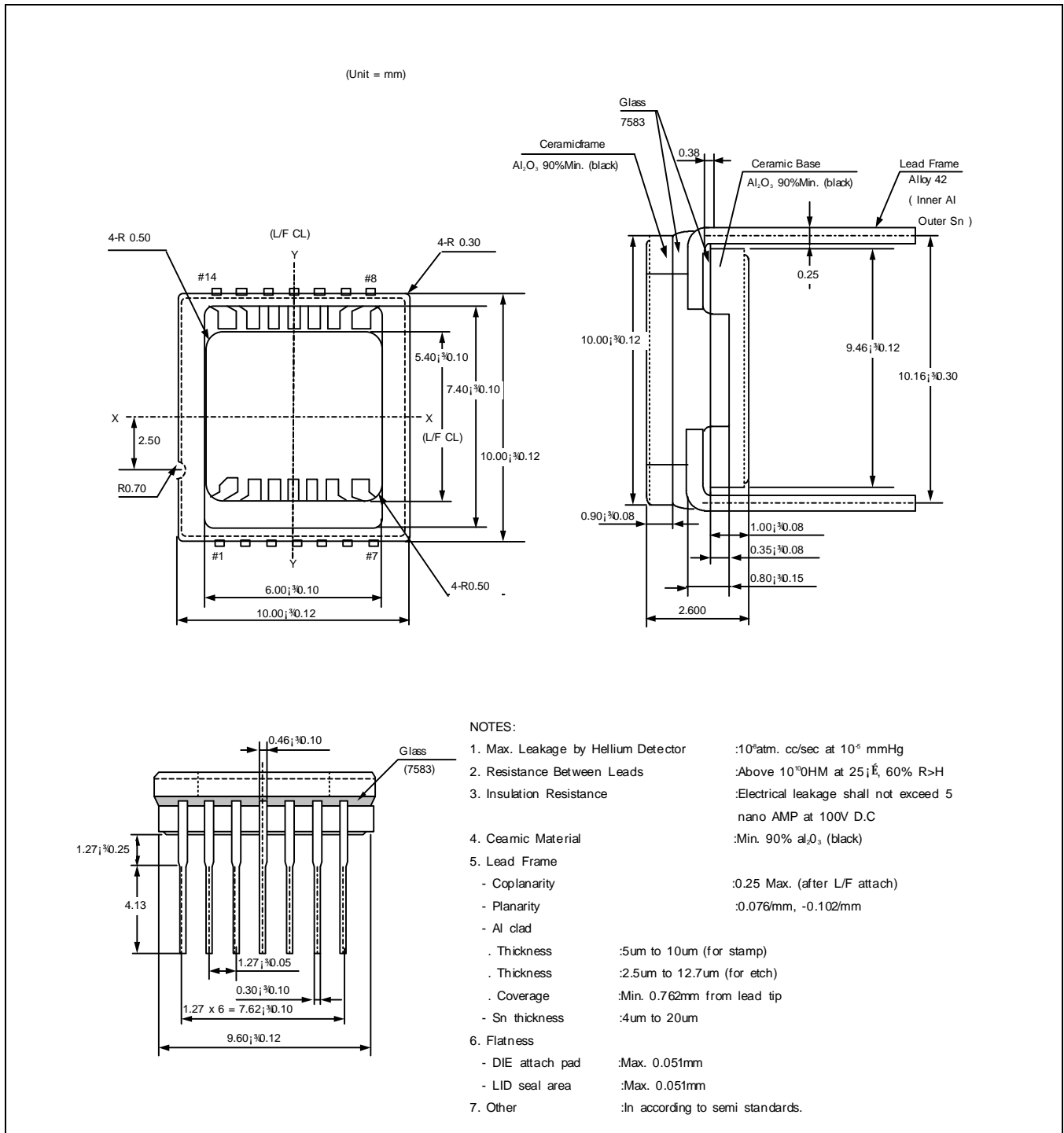

Figure 9. Package Dimensions

HANDLING INSTRUCTIONS

- **Static Charge Prevention**

CCD image sensors can be easily damaged by static discharge. Before handling, be sure to take the following protective measures.

 - Use non chargeable gloves, clothes or material. Also use conductive shoes.
 - When handling directly, use an earth band.
 - Install a conductive mat on the floor or working table to prevent generation of static electricity.
 - Ionized air is recommended for discharging when handling CCD image sensor.
 - For the shipment of mounted substrates, use boxes treated for the prevention of static charges.

- **Soldering**
 - Make sure the package temperature does not exceed 80 °C.
 - Solder dipping in a mounting furnace causes damage to the glass and other defects. Use a grounded 30W soldering iron and solder each pin in less than 2 seconds. For repairs and remount, cool sufficiently.
 - To dismount an imaging device, do not use a solder suction equipment. When using an electronic disoldering tool, use a thermal controller of the zero cross on/off type and connect to ground.

- **Dust and Dirt Protection**
 - Operate in the clean environments (around class 1000 will be appropriate).
 - Do not either touch glass plates by hand or have object come in contact with glass surface. Should dirt stick to a glass surface blow it off with an air blow (for dirt stuck through static electricity ionized air is recommended).
 - Clean with a cotton bud and ethyl alcohol if the glass surface is grease stained. Be careful not to scratch the glass.
 - Keep in case to protect from dust and dirt. To prevent dew condensation, preheat or precool when moving to a room with great temperature differences.
 - When a protective tape is applied before shipping, just before use remove the tape applied electrostatic protection. Do not reuse the tape.

- Do not expose to strong light (sun rays) for long period, color filter are discolored.

- Exposure to high temperature or humidity will affect the characteristics. accordingly avoid storage or usage in such conditions.

- CCD image sensors are precise optical equipment that should not be subject to mechanical shocks.