

S72NS-P Based MCPs/PoPs

MirrorBit™ Flash Memory and DRAM

**128/256/512 Mb (8/16/32 M x 16 bit), 1.8 Volt-only,
Multiplexed Simultaneous Read/Write, Burst Mode Flash
Memory**

128/256 Mb (8/16 M x 16 bit) DDR DRAM on Split Bus

Data Sheet (Advance Information)



Notice to Readers: This document states the current technical specifications regarding the Spanion product(s) described herein. Each product described herein may be designated as Advance Information, Preliminary, or Full Production. See [Notice On Data Sheet Designations](#) for definitions.

Notice On Data Sheet Designations

SpanSion Inc. issues data sheets with Advance Information or Preliminary designations to advise readers of product information or intended specifications throughout the product life cycle, including development, qualification, initial production, and full production. In all cases, however, readers are encouraged to verify that they have the latest information before finalizing their design. The following descriptions of SpanSion data sheet designations are presented here to highlight their presence and definitions.

Advance Information

The Advance Information designation indicates that SpanSion Inc. is developing one or more specific products, but has not committed any design to production. Information presented in a document with this designation is likely to change, and in some cases, development on the product may discontinue. SpanSion Inc. therefore places the following conditions upon Advance Information content:

“This document contains information on one or more products under development at SpanSion Inc. The information is intended to help you evaluate this product. Do not design in this product without contacting the factory. SpanSion Inc. reserves the right to change or discontinue work on this proposed product without notice.”

Preliminary

The Preliminary designation indicates that the product development has progressed such that a commitment to production has taken place. This designation covers several aspects of the product life cycle, including product qualification, initial production, and the subsequent phases in the manufacturing process that occur before full production is achieved. Changes to the technical specifications presented in a Preliminary document should be expected while keeping these aspects of production under consideration. SpanSion places the following conditions upon Preliminary content:

“This document states the current technical specifications regarding the SpanSion product(s) described herein. The Preliminary status of this document indicates that product qualification has been completed, and that initial production has begun. Due to the phases of the manufacturing process that require maintaining efficiency and quality, this document may be revised by subsequent versions or modifications due to changes in technical specifications.”

Combination

Some data sheets contain a combination of products with different designations (Advance Information, Preliminary, or Full Production). This type of document distinguishes these products and their designations wherever necessary, typically on the first page, the ordering information page, and pages with the DC Characteristics table and the AC Erase and Program table (in the table notes). The disclaimer on the first page refers the reader to the notice on this page.

Full Production (No Designation on Document)

When a product has been in production for a period of time such that no changes or only nominal changes are expected, the Preliminary designation is removed from the data sheet. Nominal changes may include those affecting the number of ordering part numbers available, such as the addition or deletion of a speed option, temperature range, package type, or V_{IO} range. Changes may also include those needed to clarify a description or to correct a typographical error or incorrect specification. SpanSion Inc. applies the following conditions to documents in this category:

“This document states the current technical specifications regarding the SpanSion product(s) described herein. SpanSion Inc. deems the products to have been in sufficient production volume such that subsequent versions of this document are not expected to change. However, typographical or specification corrections, or modifications to the valid combinations offered may occur.”

Questions regarding these document designations may be directed to your local SpanSion sales office.

S72NS-P Based MCPs/PoPs

MirrorBit™ Flash Memory and DRAM
128/256/512 Mb (8/16/32 M x 16 bit), 1.8 Volt-only,
Multiplexed Simultaneous Read/Write, Burst Mode Flash
Memory

128/256 Mb (8/16 M x 16 bit) DDR DRAM on Split Bus



Data Sheet (Advance Information)

Features

- Power supply voltage of 1.7 V to 1.95 V
- Burst Speeds
 - Flash = 66 MHz, 80 MHz
 - DRAM = 133 MHz
- Packages
 - 11.0 x 10.0 mm, 133-ball MCP
 - 8.0 x 8.0 mm, 133-ball MCP
 - 12.0 x 12.0 mm, 128-ball PoP
- Operating Temperature of -25°C to +85°C

General Description

This document contains information on the S72NS-P MCP stacked products. Refer to the S29NS-P data sheet (S29NS-P_00) for full electrical specifications of the Flash memory component.

The S72NS Series is a product line of stacked products (MCPs and PoPs), and consists of:

- NS family multiplexed Flash memory die
- DDR DRAM

The products covered by this document are listed in the tables below.

Flash Density	DRAM Density	
	128 Mb	256 Mb
128 Mb	S72NS128PD0	
256 Mb	S72NS256PD0	
512 Mb	S72NS512PD0	S72NS512PE0

For detailed specifications, please refer to the individual data sheets.

Density	Manufacturer	Publication Number
128	DRAM1	SDRAM_03
	DRAM5	SDRAM_07

Density	Manufacturer	Publication Number
256	DRAM1	TBD
	DRAM5	SDRAM_11

1. Product Selector Guide

Device OPN	Flash Density	DDR DRAM Density	Flash Speed (MHz)	DDR DRAM Speed (MHz)	Supplier	Package	
S72NS128PD0AJBGG	128 Mb	128 Mb	66	133	DRAM1	8.0 x 8.0mm133-ball MCP	
S72NS128PD0AJBGC			80				
S72NS128PD0AJBLG			66		DRAM5		
S72NS128PD0AJBLC			80				
S72NS128PD0KJFGG	128 Mb	128 Mb	66	133	DRAM1		12.0 x 12.0mm 128-ball PoP
S72NS128PD0KJFGC			80				
S72NS128PD0KJFLG			66		DRAM5		
S72NS128PD0KJFLC			80				
S72NS256PD0AJBGG	256 Mb	128 Mb	66	133	DRAM1	8.0 x 8.0mm133-ball MCP	
S72NS256PD0AJBGC			80				
S72NS256PD0AJBLG			66		DRAM5		
S72NS256PD0AJBLC			80				
S72NS256PD0KJFGG	256 Mb	128 Mb	66	133	DRAM1		12.0 x 12.0mm 128-ball PoP
S72NS256PD0KJFGC			80				
S72NS256PD0KJFLG			66		DRAM5		
S72NS256PD0KJFLC			80				
S72NS512PD0AJGGG	512 Mb	128 Mb	66	133	DRAM1	11.0 x 10.0mm 133-ball MCP	
S72NS512PD0AJGGC			80				
S72NS512PD0AJGLG			66		DRAM5		
S72NS512PD0AJGLC			80				
S72NS512PD0KJFGG	512 Mb	128 Mb	66	133	DRAM1		12.0 x 12.0mm 128-ball PoP
S72NS512PD0KJFGC			80				
S72NS512PD0KJFLG			66		DRAM5		
S72NS512PD0KJFLC			80				
S72NS512PE0AJGGG	512 Mb	256 Mb	66	133	DRAM1	11.0 x 10.0mm 133-ball MCP	
S72NS512PE0AJGGC			80				
S72NS512PE0AJGLG			66		DRAM5		
S72NS512PE0AJGLC			80				
S72NS512PE0KJFGG	512 Mb	256 Mb	66	133	DRAM1		12.0 x 12.0mm 128-ball PoP
S72NS512PE0KJFGC			80				
S72NS512PE0KJFLG			66		DRAM5		
S72NS512PE0KJFLC			80				

2. Product Block Diagram

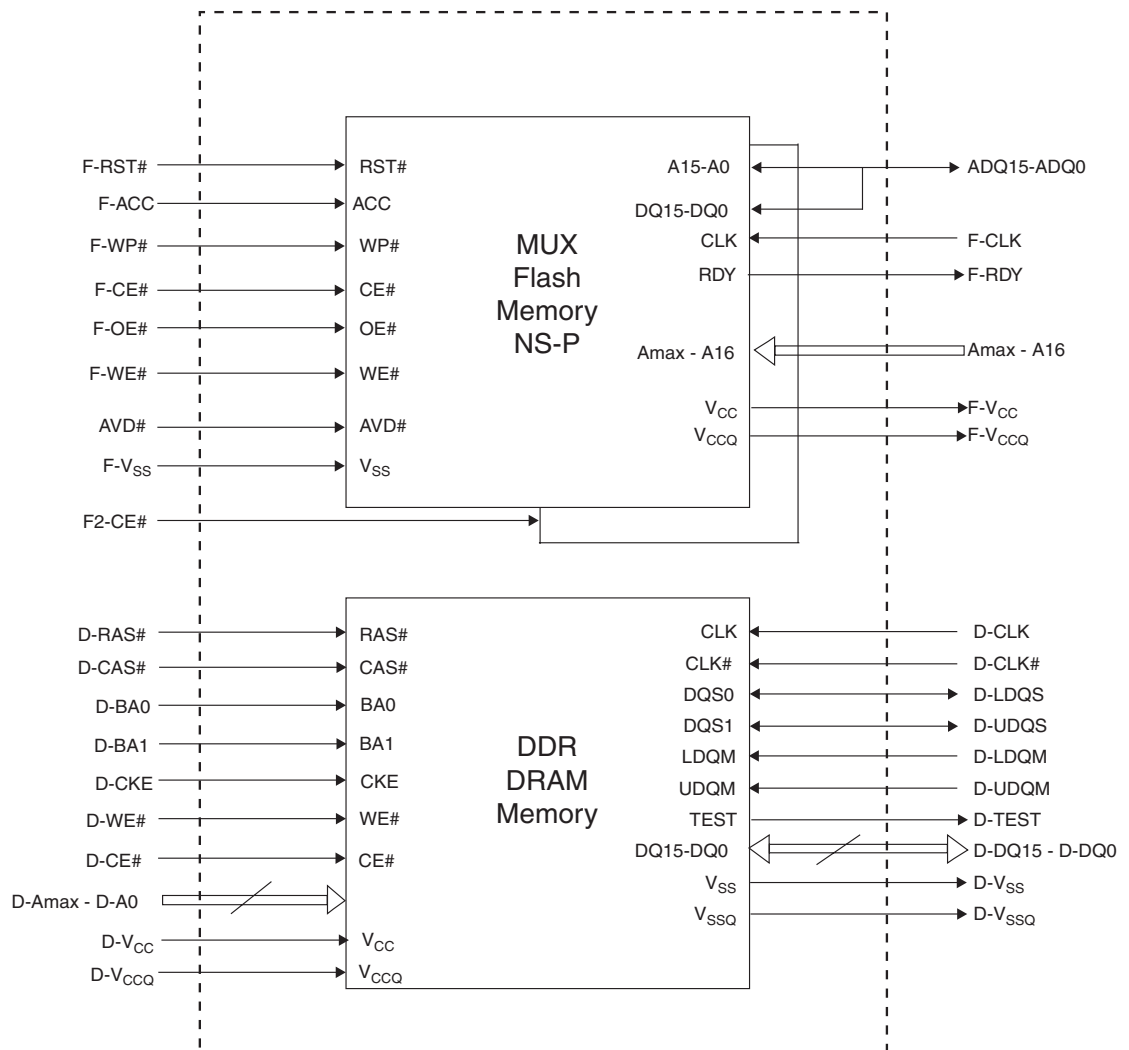

Notes:

- Amax indicates highest address bit for memory component:
 - Amax = A24 for NS512P, A23 for NS256P, A22 for NS128P
 - Amax = A11 for 128 Mb DDR DRAM
 - Amax = A12 for 256Mb DDR DRAM
- For Flash, A15 - A0 is tied to DQ15 - DQ0.

3. Connection Diagrams

Figure 3.1 133-ball Fine-Pitch Ball Grid Array MCP

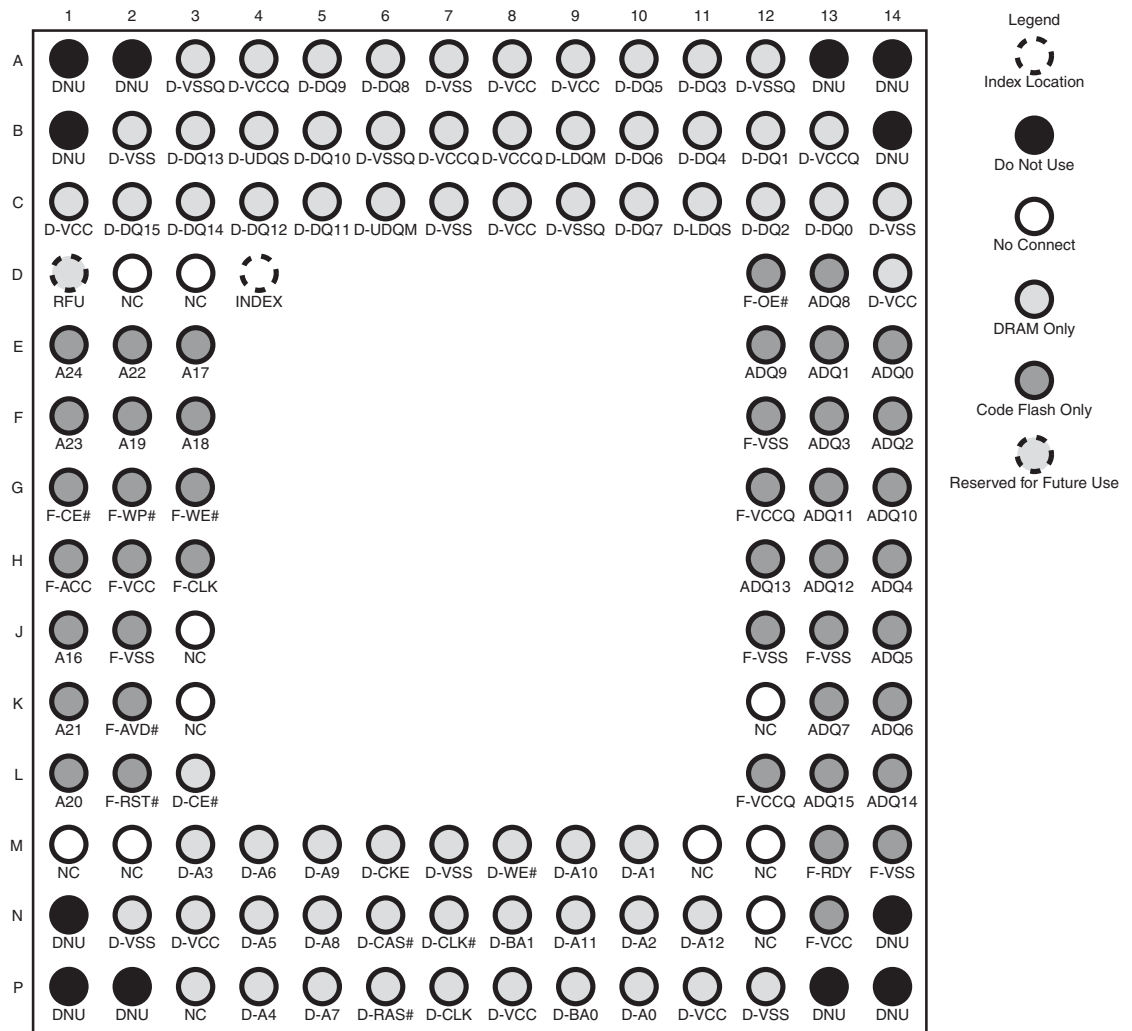

Note:
Additional NC locations are in reference to the superset connection diagram shown here

Device OPN	Flash Address Amax	DDR DRAM Address Amax	Additional NC Locations
S72NS128PD0	A22	A11	Ball F1, Ball E1, Ball N11
S72NS256PD0	A23	A11	Ball E1, Ball N11
S72NS512PD0	A24	A11	Ball N11
S72NS512PE0	A24	A12	N/A

Figure 3.2 128-ball Fine-Pitch Ball Grid Array, PoP

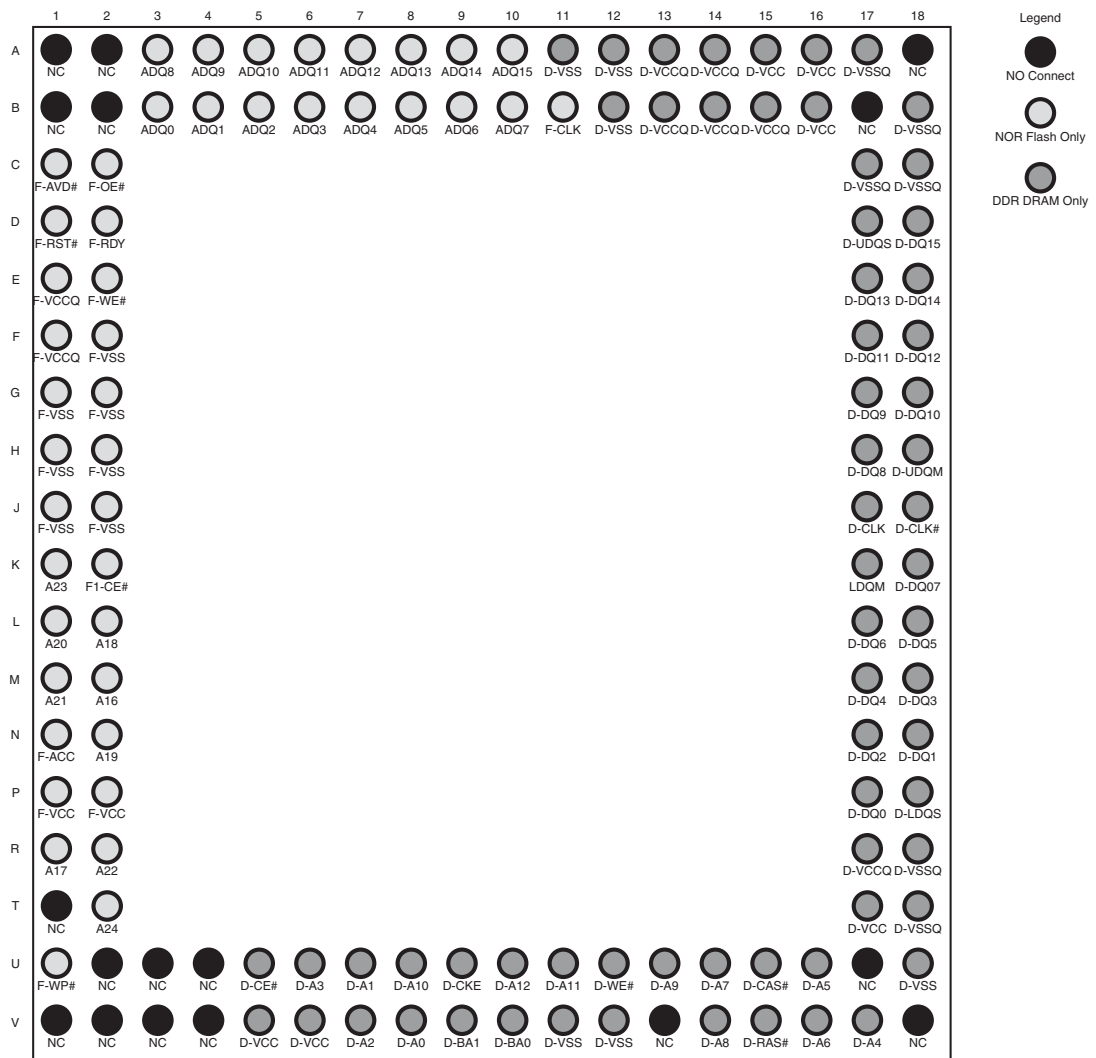

Note:
Additional NC locations are in reference to the superset connection diagram shown here.

Device OPN	Flash Address Amax	DDR DRAM Address Amax	Additional NC Locations
S72NS128PD0	A22	A11	Ball K1, Ball T2, Ball U10
S72NS256PD0	A23	A11	Ball K1, Ball U10
S72NS512PD0	A24	A11	Ball U10
S72NS512PE0	A24	A12	N/A

4. Input/Output Descriptions

Signal		Description	Flash	DRAM
Amax – A16	=	Flash Address inputs		
ADQ15 – ADQ0	=	Flash multiplexed Address and Data		
F-CE#	=	Flash Chip-enable input. Asynchronous relative to CLK for Burst Mode	X	
F-OE#	=	Flash Output Enable input. Asynchronous relative to CLK for Burst mode.	X	
F-WE#	=	Flash Write Enable input	X	
F-VCC	=	Flash device power supply (1.7 V to 1.95 V)	X	
F-VCCQ	=	Flash Input/Output Buffer power supply	X	
F-VSS	=	Flash Ground	X	
F-RDY	=	Flash ready output. Indicates the status of the Burst read. V_{OL} = data invalid. V_{OH} = data valid.	X	
F-CLK	=	Flash Clock. The first rising edge of CLK in conjunction with AVD# low latches the address input and activates burst mode operation. After the initial word is output, subsequent rising edges of CLK increment the internal address counter. CLK should remain low during asynchronous access.	X	
F-AVD#	=	Flash Address Valid input. Indicates to device that the valid address is present on the address inputs. V_{IL} = for asynchronous mode, indicates valid address; for burst mode, causes starting address to be latched on rising edge of CLK. V_{IH} = device ignores address inputs	X	
F-RST#	=	Flash hardware reset input. V_{IL} = device resets and returns to reading array data	X	
F-WP#	=	Flash hardware write protect input. V_{IL} = disables program and erase functions in the four outermost sectors	X	
F-ACC	=	Flash accelerated input. At V_{HH} , accelerates programming; automatically places device in unlock bypass mode. At V_{IL} , disables all program and erase functions. Should be at V_{IH} for all other conditions.	X	
D-A12 – D-A0	=	DRAM Address inputs.		X
D-DQ15 – D-DQ0	=	DRAM Data input/output		X
D-CLK	=	DRAM System Clock		X
D-CE#	=	DRAM Chip Select		X
D-CKE	=	DRAM Clock Enable		X
D-BA1 – BA0	=	DRAM Bank Select		X
D-RAS#	=	DRAM Row Address Strobe		X
D-CAS#	=	DRAM Column Address Strobe		X
D-UDQM – D-LDQM	=	DRAM Data Input Mask		X
D-WE#	=	DRAM Write Enable input		X
D-VSS	=	DRAM Ground		X
D-VSSQ	=	DRAM Input/Output Buffer ground		X
D-VCCQ	=	DRAM Input/Output Buffer power supply		X
D-VCC	=	DRAM device power supply		X
D-UDQS	=	DRAM Upper Data Strobe, output with read data and input with write data		X
D-LDQS	=	DRAM Lower Data Strobe, output with read data and input with write data		X
D-CLK#	=	DDR Clock for negative edge of CLK		X
RFU	=	Reserved for Future Use		
NC	=	No Connect. Can be connected to ground or left floating.		
DNU	=	Do Not Use. This signal must be left floating		

5. Ordering Information

The order number (Valid Combination) is formed by the following:

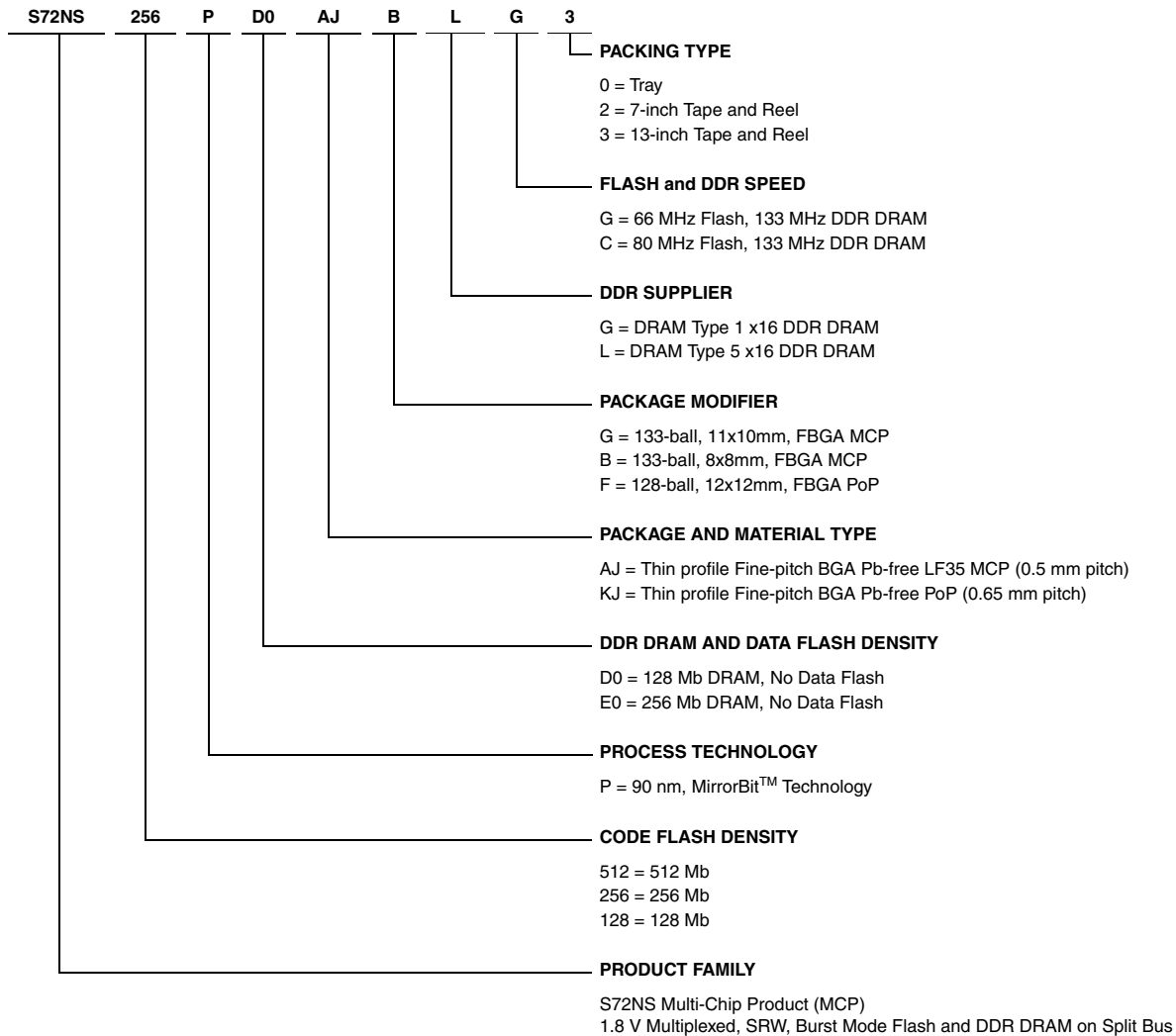

Valid Combinations							
Product Family	Code Flash Density (Mb)	Process Technology	DRAM Density (Mb)	Package Type/ Material	DDR Vendor	Flash & DDR Speed	Packing Type
S72NS	128	P	D0	AJB, KJF	G, L	G, C	0, 2, 3 (Note 1)
	256					G, C	
	512		D0, E0	AJG, KJF			

Notes:

- Packing Type 0 is standard. Specify other options as required.
- BGA package marking omits leading "S" and packing type designator from ordering part number.
- Valid Combinations list configurations planned to be supported in volume for this device. Consult your local sales office to confirm availability of specific valid combinations and to check on newly released combinations.

6. Physical Dimensions

6.1 NLC133—133-ball Fine-Pitch Ball Grid Array (FBGA) 11.0 x 10.0 mm

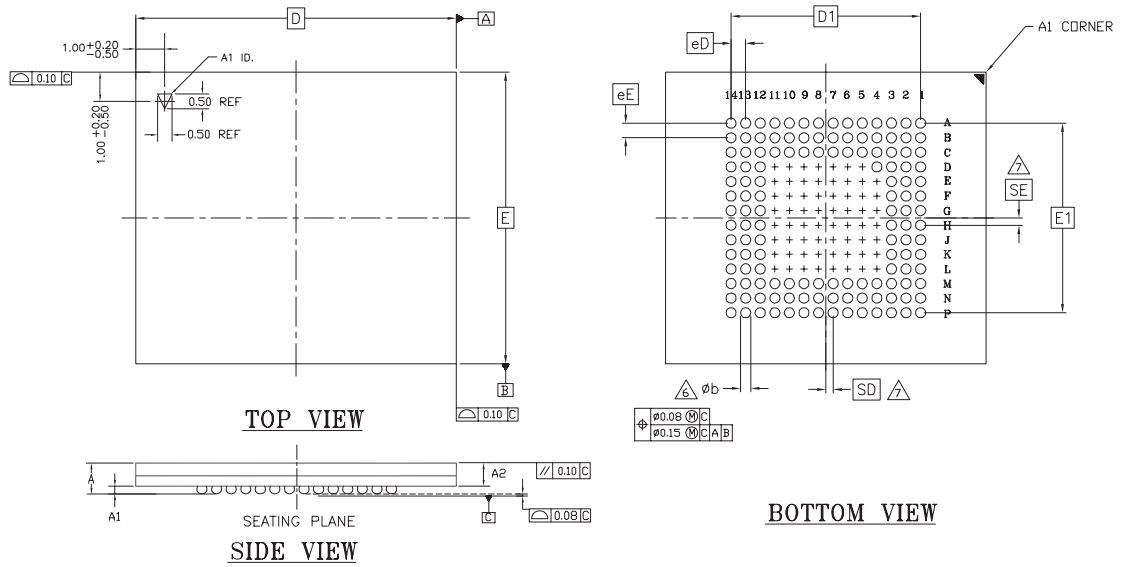

PACKAGE	NLC 133			NOTE
JEDEC	N/A			
D x E	11.0 mm x 10.00 mm PACKAGE			
SYMBOL	MIN	NOM	MAX	
A	0.90	1.00	1.10	PROFILE
A1	0.20	0.25	0.30	BALL HEIGHT
A2	0.70	0.76	0.82	BODY THICKNESS
D	10.9	11.0	11.1	BODY SIZE
E	9.9	10.0	10.1	BODY SIZE
D1	6.50 BSC.			MATRIX FOOTPRINT
E1	6.50 BSC.			MATRIX FOOTPRINT
MD	14			MATRIX SIZE D DIRECTION
ME	14			MATRIX SIZE E DIRECTION
n	133			BALL COUNT
Øb	0.25	0.30	0.35	BALL DIAMETER
eE	0.50 BSC.			BALL PITCH
eD	0.50 BSC.			BALL PITCH
SD / SE	0.25 BSC.			SOLDER BALL PLACEMENT
	D5-D11, E4-E11, F4-F11 G4-G11, H4-H11, J4-J11 K4-K11, L4-L11			DEPOPULATED SOLDER BALLS

NOTES:

- DIMENSIONING AND TOLERANCING METHODS PER ASME Y14.5M-1994.
- ALL DIMENSIONS ARE IN MILLIMETERS.
- BALL POSITION DESIGNATION PER JESD 95-1, SPP-010.
- [e] REPRESENTS THE SOLDER BALL GRID PITCH.
- SYMBOL "MD" IS THE BALL MATRIX SIZE IN THE "D" DIRECTION.
SYMBOL "ME" IS THE BALL MATRIX SIZE IN THE "E" DIRECTION.
n IS THE NUMBER OF POPULATED SOLDER BALL POSITIONS FOR MATRIX SIZE MD X ME.
- [6] DIMENSION "b" IS MEASURED AT THE MAXIMUM BALL DIAMETER IN A PLANE PARALLEL TO DATUM C.
- [7] SD AND SE ARE MEASURED WITH RESPECT TO DATUMS A AND B AND DEFINE THE POSITION OF THE CENTER SOLDER BALL IN THE OUTER ROW.
WHEN THERE IS AN ODD NUMBER OF SOLDER BALLS IN THE OUTER ROW SD OR SE = 0.000.
WHEN THERE IS AN EVEN NUMBER OF SOLDER BALLS IN THE OUTER ROW, SD OR SE = [e/2]
- "+" INDICATES THE THEORETICAL CENTER OF DEPOPULATED BALLS.
- N/A
- [A1] A1 CORNER TO BE IDENTIFIED BY CHAMFER, LASER OR INK MARK, METALLIZED MARK INDENTATION OR OTHER MEANS.

3436 \ 16-039.22 \ 12.09.04

6.2 NSC133—133-ball Fine-Pitch Ball Grid Array (FBGA) 8.0 x 8.0 mm

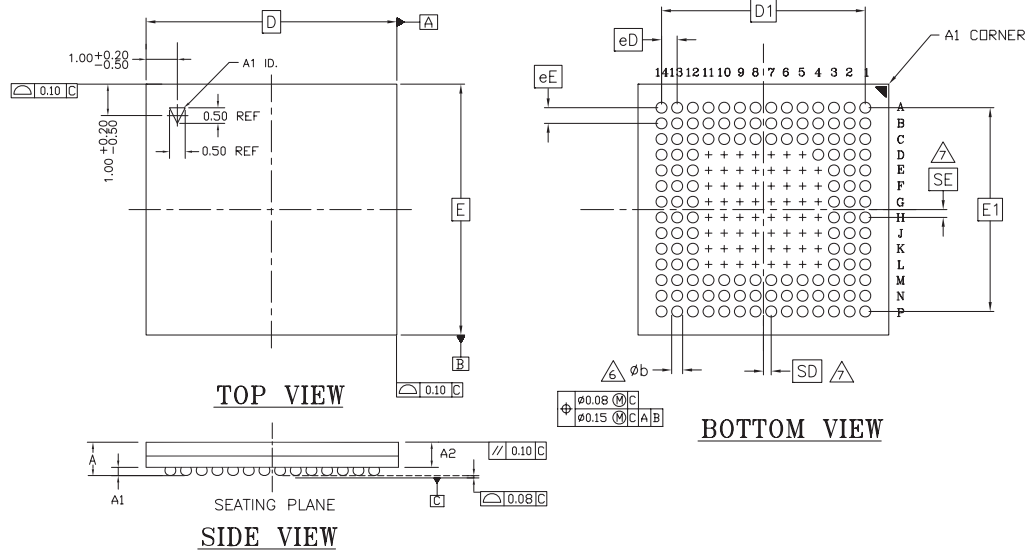

PACKAGE	NSC 133			NOTE
JEDEC	N/A			
D x E	8.00 mm x 8.00 mm PACKAGE			
SYMBOL	MIN	NOM	MAX	
A	0.90	1.00	1.10	PROFILE
A1	0.20	0.25	0.30	BALL HEIGHT
A2	0.70	0.76	0.82	BODY THICKNESS
D	8.00 BSC			BODY SIZE
E	8.00 BSC			BODY SIZE
D1	6.50 BSC.			MATRIX FOOTPRINT
E1	6.50 BSC.			MATRIX FOOTPRINT
MD	14			MATRIX SIZE D DIRECTION
ME	14			MATRIX SIZE E DIRECTION
n	133			BALL COUNT
Øb	0.25	0.30	0.35	BALL DIAMETER
eE	0.50 BSC.			BALL PITCH
eD	0.50 BSC			BALL PITCH
SD/SE	0.25 BSC.			SOLDER BALL PLACEMENT
	D5-D11, E4-E11, F4-F11, G4-G11 H4-H11, J4-J11, K4-K11, L4-L11			DEPOPULATED SOLDER BALLS

NOTES:

- DIMENSIONING AND TOLERANCING METHODS PER ASME Y14.5M-1994.
- ALL DIMENSIONS ARE IN MILLIMETERS.
- BALL POSITION DESIGNATION PER JESD 95-1 SPP-010.
- [e] REPRESENTS THE SOLDER BALL GRID PITCH.
- SYMBOL "MD" IS THE BALL MATRIX SIZE IN THE "D" DIRECTION.
SYMBOL "ME" IS THE BALL MATRIX SIZE IN THE "E" DIRECTION.
n IS THE NUMBER OF POPULATED SOLDER BALL POSITIONS FOR MATRIX SIZE MD X ME.
- DIMENSION "b" IS MEASURED AT THE MAXIMUM BALL DIAMETER IN A PLANE PARALLEL TO DATUM C.
- SD AND SE ARE MEASURED WITH RESPECT TO DATUMS A AND B AND DEFINE THE POSITION OF THE CENTER SOLDER BALL IN THE OUTER ROW.
WHEN THERE IS AN ODD NUMBER OF SOLDER BALLS IN THE OUTER ROW SD OR SE = 0.000.
WHEN THERE IS AN EVEN NUMBER OF SOLDER BALLS IN THE OUTER ROW, SD OR SE = [e/2]
- "+" INDICATES THE THEORETICAL CENTER OF DEPOPULATED BALLS.
- A1 CORNER TO BE IDENTIFIED BY CHAMFER, LASER OR INK MARK, METALLIZED MARK INDENTATION OR OTHER MEANS.

3583 \ 16-039.22 \ 8.15.06

6.3 ALJ128—128-ball Fine-Pitch Ball Grid Array (FBGA) 12.0 x 12.0 mm

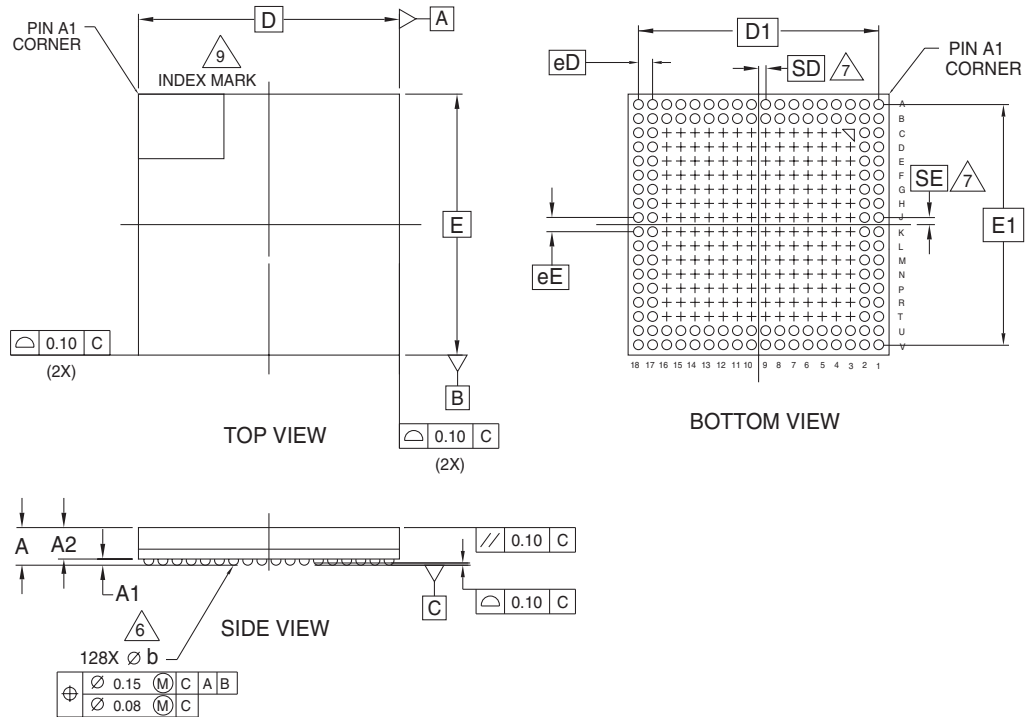

PACKAGE	ALJ 128			NOTE
JEDEC	N/A			
D x E	12.00 mm x 12.00 mm PACKAGE			
SYMBOL	MIN	NOM	MAX	
A	---	---	1.15	PROFILE
A1	0.35	---	---	BALL HEIGHT
A2	0.60	---	0.72	BODY THICKNESS
D	12.00 BSC.			BODY SIZE
E	12.00 BSC.			BODY SIZE
D1	11.05 BSC.			MATRIX FOOTPRINT
E1	11.05 BSC.			MATRIX FOOTPRINT
MD	18			MATRIX SIZE D DIRECTION
ME	18			MATRIX SIZE E DIRECTION
n	128			BALL COUNT
N	128			MAXIMUM NUMBER OF BALLS
R	2			NUMBER OF LAND PERIMETERS
Øb	0.40	0.45	0.50	BALL DIAMETER
eE	0.65 BSC.			BALL PITCH
eD	0.65 BSC.			BALL PITCH
SE / SD	0.325 BSC.			SOLDER BALL PLACEMENT
	C3-C16, D3-D16, E3-E16, F3-F16 G3-G16, H3-H16, J3-J16, K3-K16 L3-L16, M3-M16, N3-N16, P3-P16 R3-R16, T3-T16			DEPOPULATED SOLDER BALLS

NOTES:

- DIMENSIONING AND TOLERANCING METHODS PER ASME Y14.5M-1994.
- ALL DIMENSIONS ARE IN MILLIMETERS.
- BALL POSITION DESIGNATION PER JEP95, SECTION 3.0, SPP-010.
- [e] REPRESENTS THE SOLDER BALL GRID PITCH.
- SYMBOL "MD" IS THE BALL MATRIX SIZE IN THE "D" DIRECTION.
SYMBOL "ME" IS THE BALL MATRIX SIZE IN THE "E" DIRECTION.
n IS THE NUMBER OF POPULATED SOLDER BALL POSITIONS FOR MATRIX SIZE MD X ME.
N IS THE MAXIMUM NUMBER OF BALLS ON THE FBGA PACKAGE.
- △6 DIMENSION "b" IS MEASURED AT THE MAXIMUM BALL DIAMETER IN A PLANE PARALLEL TO DATUM C.
DATUM C IS THE SEATING PLANE AND IS DEFINED BY THE CROWNS OF THE SOLDER BALLS.
- △7 SD AND SE ARE MEASURED WITH RESPECT TO DATUMS A AND B AND DEFINE THE POSITION OF THE CENTER SOLDER BALL IN THE OUTER ROW.
WHEN THERE IS AN ODD NUMBER OF SOLDER BALLS IN THE OUTER ROW SD OR SE = 0.000.
WHEN THERE IS AN EVEN NUMBER OF SOLDER BALLS IN THE OUTER ROW, SD OR SE = [e/2]
- "+" INDICATES THE THEORETICAL CENTER OF DEPOPULATED BALLS.
- △9 A1 CORNER TO BE IDENTIFIED BY CHAMFER, LASER OR INK MARK, METALLIZED MARK INDENTATION OR OTHER MEANS.
- 10 OUTLINE AND DIMENSIONS PER CUSTOMER REQUIREMENT.

9561 16 090 041 E 1E 2

6.4 ASF128—128-ball Fine-Pitch Ball Grid Array (FBGA) 12.0 x 12.0 mm

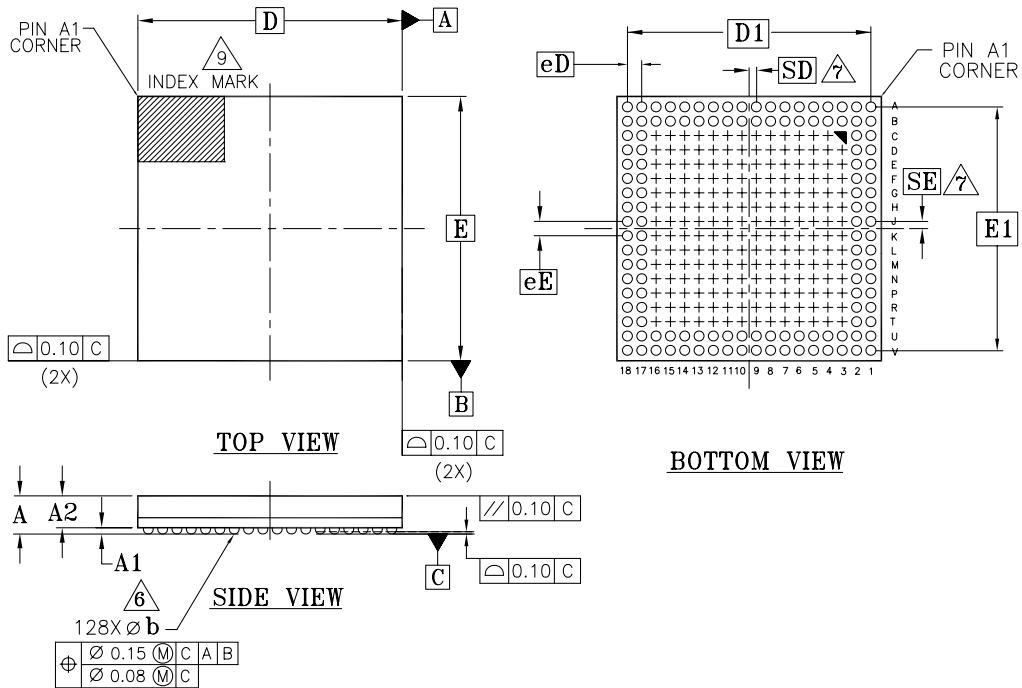

SYMBOL	MIN	NOM	MAX	NOTE
A	0.95	1.05	1.15	PROFILE
A1	0.35	0.40	0.45	BALL HEIGHT
A2	0.59	---	0.72	BODY THICKNESS
D	12.00 BSC.			BODY SIZE
E	12.00 BSC.			BODY SIZE
D1	11.05 BSC.			MATRIX FOOTPRINT
E1	11.05 BSC.			MATRIX FOOTPRINT
MD	18			MATRIX SIZE D DIRECTION
ME	18			MATRIX SIZE E DIRECTION
n	128			BALL COUNT
N	128			MAXIMUM NUMBER OF BALLS
R	2			NUMBER OF LAND PERIMETERS
Øb	0.40	0.45	0.50	BALL DIAMETER
eE	0.65 BSC.			BALL PITCH
eD	0.65 BSC.			BALL PITCH
SE / SD	0.325 BSC.			SOLDER BALL PLACEMENT
	C3-C16, D3-D16, E3-E16, F3-F16, G3-G16, H3-H16, J3-J16, K3-K16, L3-L16, M3-M16, N3-N16, P3-P16, R3-R16, T3-T16			DEPOPULATED SOLDER BALLS

NOTES:

- DIMENSIONING AND TOLERANCING METHODS PER ASME Y14.5M-1994.
- ALL DIMENSIONS ARE IN MILLIMETERS.
- BALL POSITION DESIGNATION PER JEP95, SECTION 3.0, SPP-010.
- [e] REPRESENTS THE SOLDER BALL GRID PITCH.
- SYMBOL "MD" IS THE BALL MATRIX SIZE IN THE "D" DIRECTION.
SYMBOL "ME" IS THE BALL MATRIX SIZE IN THE "E" DIRECTION.
n IS THE NUMBER OF POPULATED SOLDER BALL POSITIONS FOR MATRIX SIZE MD X ME.
N IS THE MAXIMUM NUMBER OF BALLS ON THE FBGA PACKAGE.
- DIMENSION "b" IS MEASURED AT THE MAXIMUM BALL DIAMETER IN A PLANE PARALLEL TO DATUM C.
DATUM C IS THE SEATING PLANE AND IS DEFINED BY THE CROWNS OF THE SOLDER BALLS.
- SD AND SE ARE MEASURED WITH RESPECT TO DATUMS A AND B AND DEFINE THE POSITION OF THE CENTER SOLDER BALL IN THE OUTER ROW.
WHEN THERE IS AN ODD NUMBER OF SOLDER BALLS IN THE OUTER ROW SD OR SE = 0.000.
WHEN THERE IS AN EVEN NUMBER OF SOLDER BALLS IN THE OUTER ROW, SD OR SE = [e/2]
- "*" INDICATES THE THEORETICAL CENTER OF DEPOPULATED BALLS.
- A1 CORNER TO BE IDENTIFIED BY CHAMFER, LASER OR INK MARK, METALLIZED MARK INDENTATION OR OTHER MEANS.
- OUTLINE AND DIMENSIONS PER CUSTOMER REQUIREMENT.

3581116-039 2418.3.6

7. Revision History

7.1 Revision 01 (September 6, 2006)

Initial release.

Colophon

The products described in this document are designed, developed and manufactured as contemplated for general use, including without limitation, ordinary industrial use, general office use, personal use, and household use, but are not designed, developed and manufactured as contemplated (1) for any use that includes fatal risks or dangers that, unless extremely high safety is secured, could have a serious effect to the public, and could lead directly to death, personal injury, severe physical damage or other loss (i.e., nuclear reaction control in nuclear facility, aircraft flight control, air traffic control, mass transport control, medical life support system, missile launch control in weapon system), or (2) for any use where chance of failure is intolerable (i.e., submersible repeater and artificial satellite). Please note that Spansion will not be liable to you and/or any third party for any claims or damages arising in connection with above-mentioned uses of the products. Any semiconductor devices have an inherent chance of failure. You must protect against injury, damage or loss from such failures by incorporating safety design measures into your facility and equipment such as redundancy, fire protection, and prevention of over-current levels and other abnormal operating conditions. If any products described in this document represent goods or technologies subject to certain restrictions on export under the Foreign Exchange and Foreign Trade Law of Japan, the US Export Administration Regulations or the applicable laws of any other country, the prior authorization by the respective government entity will be required for export of those products.

Trademarks and Notice

The contents of this document are subject to change without notice. This document may contain information on a Spansion product under development by Spansion. Spansion reserves the right to change or discontinue work on any product without notice. The information in this document is provided as is without warranty or guarantee of any kind as to its accuracy, completeness, operability, fitness for particular purpose, merchantability, non-infringement of third-party rights, or any other warranty, express, implied, or statutory. Spansion assumes no liability for any damages of any kind arising out of the use of the information in this document.

Copyright © 2006 Spansion Inc. All Rights Reserved. Spansion, the Spansion logo, MirrorBit, ORNAND, and combinations thereof are trademarks of Spansion Inc. Other names are for informational purposes only and may be trademarks of their respective owners.