

CMOS HF CLOCK (XO)
S9-X13AXXX Series

Description

The **S9-X13AXXX Series** of quartz crystal oscillators provide high frequency with CMOS/LVCMOS output. The output can be tri-stated for test automation or combining multiple clocks. The device is based on low noise analog harmonic multiplication, and packaged in a miniature, low profile leadless FR4 based package with gold plated pads, which enhances compatibility with PCB material.

Applications and Features

- High Frequency - 125MHz to 220MHz
- Fiber Channel: 10 GbE; Infiniband; Network Processors; SOHO Routing
- High Reliability - NEL HALT/HASS qualified for crystal oscillator start-up conditions
- Low Phase Noise, Low Jitter
- Tight frequency stability - ± 20 ppm overall available
- RoHS compliant, Lead Free Construction
- Low cost

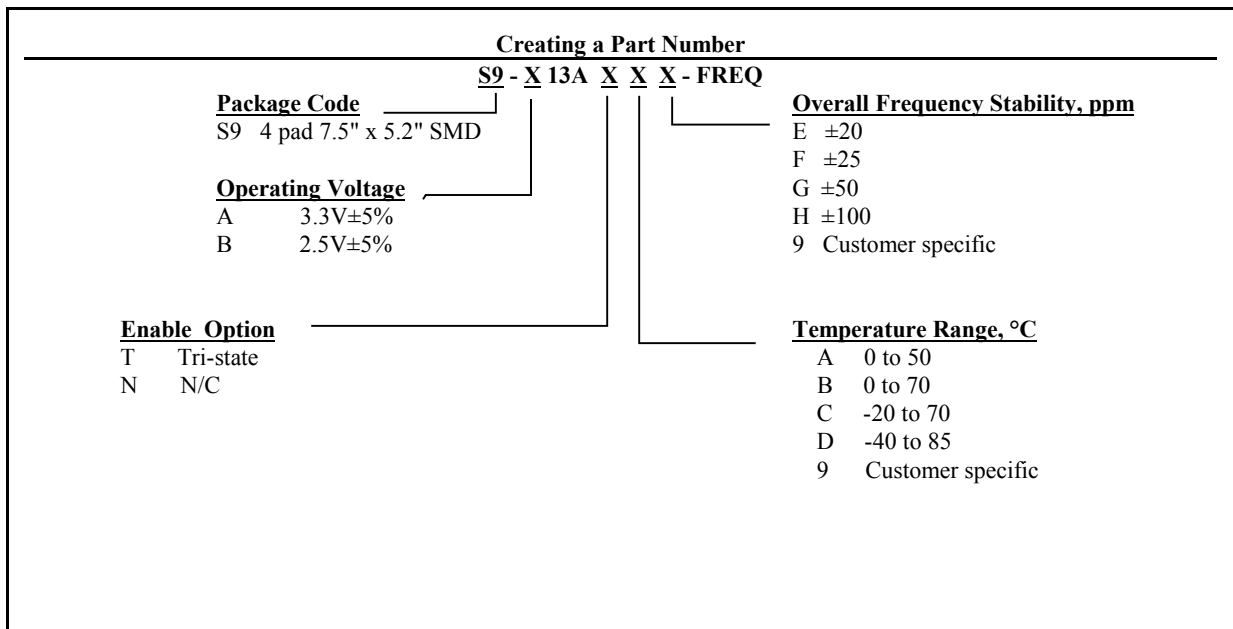

S9-X13AXXX Series Continued
CMOS HF CLOCK (XO)

Rev. -

Absolute Maximum Ratings

Parameter	Symbol	Value	Unit
Operating Temperature Range	To	-40 to +85	°C
Storage Temperature Range	Tst	-50 to +90	°C
Supply Voltage	Vcc	-0.5 to 4.5	V
Enable/Disable Voltage	Ven/dis	0 to Vcc	V

Electrical Parameters

Parameter	Sym	Conditions	MIN	TYP	MAX	Unit
Nominal Frequency	Fo		125		220	MHz
Supply Voltage	Vcc	Code A Code B	3.135 2.375	3.3 2.5	3.465 2.625	V
Supply Current	Icc			6	80	mA
Load		At receiving end between the output	90	100	110	Ohm
Output Levels	Vod	Differential amplitude	247	330	454	mV
		Amplitude error			50	mV
	Vof	Offset Voltage	1.125	1.25	1.375	V
		Offset voltage error			50	mV
Duty Cycle (Symmetry)		At outputs crossing, room temperature	45/55	50/50	55/45	%
Rise/Fall Time	Tr/Tf	20 to 80, 80 to 20%		0.35	0.4	ns
Jitter, Integrated	J	Integrated from Phase Noise, 12KHz to 20MHz, RMS		0.2		ps
Jitter, Wavecrest characterized		Random , period		2.5		ps
		Accuml, pk to pk		25		ps
		Deterministic		3	6	ps
Sub-harmonics		<400 M		-50		dBc
		>400 M		-45		
Phase Noise	£(°f)	@10 Hz		-65		dBc/Hz
		@100 Hz		-95		
		@1 KHz		-125		
		@10KHz		-140		
		@100KHz		-145		
		@>1mHz		-148		
Frequency Stability	° F/F	Overall, including initial calibration, temperature, aging 10 years, shock and vibration	See "Creating a Part Number", Not all combinations available, consult factory			ppm
Enable High Option						
Pin 1 Disabled		CMOS Logic "0"	0		0.3Vcc	V
Pin 1 Enabled		CMOS Logic "1"	0.7Vcc		Vcc	



S9-X13AXXX Series Continued CMOS HF CLOCK (XO)

Electrical Connection

Pin	Connection
1	Tri-state or No Connect
2	Gnd
3	OUT
4	Vcc

Dimension are typical in mm

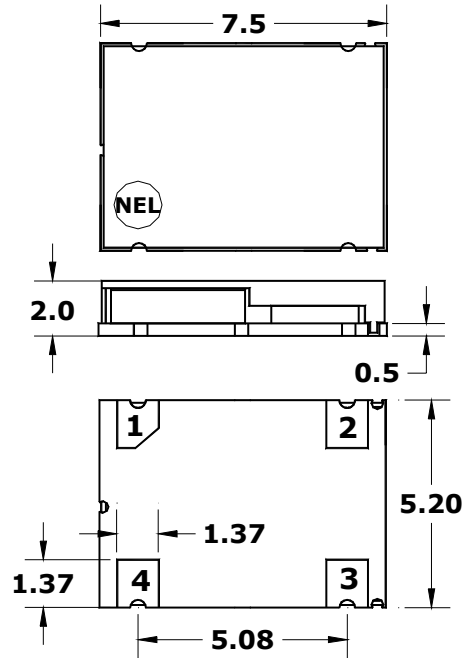

Environmental and Mechanical Characteristics

Operating temp. range	See part Number Table
Mechanical Shock	Per MIL-STD-202, Method 213, Cond. E
Thermal Shock	Per MIL-STD-883, Method 1011, Cond. A
Vibration	Per MIL-STD-883, Method 2007, Cond. A
Hermetic Seal	Leak rate less than 1×10^{-8} atm.cc/s of helium (crystal only)
Soldering conditions	See MAX reflow profile below

Maximum Reflow Profile

