

# DATA SHEET



## **SAA8116**

Digital PC-camera signal processor  
including microcontroller and USB  
interface

Product specification  
Supersedes data of 2000 Dec 6  
File under Integrated Circuits, IC22

2001 May 04

# Digital PC-camera signal processor including microcontroller and USB interface

## SAA8116

### FEATURES

- Embedded microcontroller (80C51 core based) for control loops Auto Optical Black (AOB), Auto White Balance (AWB), Auto Exposure (AE) and USB interface control
- Compliant for VGA CCD and VGA CMOS sensors (RGB Bayer)
- USB 1.1 compliant bus-powered USB device with integrated power management and POR circuit
- RGB processing
- Optical black processing
- Defect pixel concealment
- Programmable colour matrix
- RGB to YUV transform
- Programmable gamma correction (including knee)
- Programmable edge enhancement
- Video formatter with SIF/QSIF downscaler
- Compression engine
- Flexible Measurement Engine (ME) with up to eight measurements per frame
- Internal Pulse Pattern Generator (PPG) for wide range of VGA CCDs (Sony, Sharp and Panasonic) and frame rate selection
- Programmable H and V timing for the support of CMOS sensors
- Programmable output pulse for switched mode power supply of the sensor
- 3-wire interface to control an external pre-processor IC, such as the TDA8787A: Correlated Double Sampling (CDS), Automatic Gain Control (AGC) and 10-bit ADC
- Analog microphone/audio input to USB: Low DropOut (LDO) supply filter, microphone supply, low noise amplifier, programmable amplifier, PLL and ADC
- Integrated analog USB driver (ATX)
- Integrated main oscillator, including a clock PLL, which derives 48 MHz main system clock from a 12 or 48 MHz fundamental crystal.



### APPLICATION

- USB PC-camera (video and audio).

### GENERAL DESCRIPTION

The SAA8116 is a highly integrated third generation USB PC-camera ICs. It is the successor to the SAA8112HL and SAA8115HL. It processes the digitized sensor data and converts it to a high quality, compressed YUV signal. Together with the audio signal, this video signal is then properly formatted in USB packets.

In addition, an 80C51 microcontroller derivative with five I/O ports, I<sup>2</sup>C-bus, 512 bytes of RAM and 32 kbytes of program memory is embedded in the SAA8116. The microcontroller is used in combination with the programmable statistical measurement capabilities to provide advanced AE, AWB and AOB. The microcontroller is also used to control the USB interface.

### ORDERING INFORMATION

TYPE NUMBER	PACKAGE		
	NAME	DESCRIPTION	VERSION
SAA8116HL	LQFP100	plastic low profile quad flat package; 100 leads; body 14 × 14 × 1.4 mm	SOT407-1
SAA8116ET	TFBGA112	plastic thin fine-pitch ball grid array package; 112 balls; body 7 × 7 × 0.8 mm	SOT630-1

# Digital PC-camera signal processor including microcontroller and USB interface

SAA8116

## QUICK REFERENCE DATA

Measured over full voltage and temperature range:  $V_{DD} = 3.3 \text{ V} \pm 10\%$  and  $T_{amb} = 0 \text{ to } 70 \text{ }^\circ\text{C}$ ; unless specified.

SYMBOL	PARAMETER	CONDITIONS	MIN.	TYP.	MAX.	UNIT
$V_{DD}$	supply voltage		3.0	3.3	3.6	V
$I_{DD(\text{tot})}$	total supply current	$V_{DD} = 3.3 \text{ V}$ ; $T_{amb} = 25 \text{ }^\circ\text{C}$ (typ.)	–	85 <sup>(1)</sup>	105 <sup>(2)</sup>	mA
$V_i$	input voltage	$3.0 \text{ V} < V_{DD} < 3.6 \text{ V}$	low voltage TTL compatible			V
$V_o$	output voltage	$3.0 \text{ V} < V_{DD} < 3.6 \text{ V}$	low voltage TTL compatible			V
$f_{(i)\text{xtal}}$	crystal input frequency	note 3	–	12 or 48	–	MHz
$\delta$	crystal frequency duty factor		–	50	–	%
$P_{\text{tot}}$	total power dissipation; note 1	$V_{DD} = 3.3 \text{ V}$ ; $T_{amb} = 25 \text{ }^\circ\text{C}$ (typ.)	–	280	350	mW
$T_{\text{stg}}$	storage temperature		–55	–	+150	$^\circ\text{C}$
$T_{\text{amb}}$	ambient temperature		0	25	70	$^\circ\text{C}$
$T_j$	junction temperature	$T_{amb} = 70 \text{ }^\circ\text{C}$	–40	–	+125	$^\circ\text{C}$

### Notes

1. Typical: VGA at 15 fps.
2. Maximum: SIF at 30 fps.
3. The crystal input frequency can be 12 or 48 MHz, depending on the use of the internal CPLL (selectable via pin XSEL).

# Digital PC-camera signal processor including microcontroller and USB interface

SAA8116

## BLOCK DIAGRAM

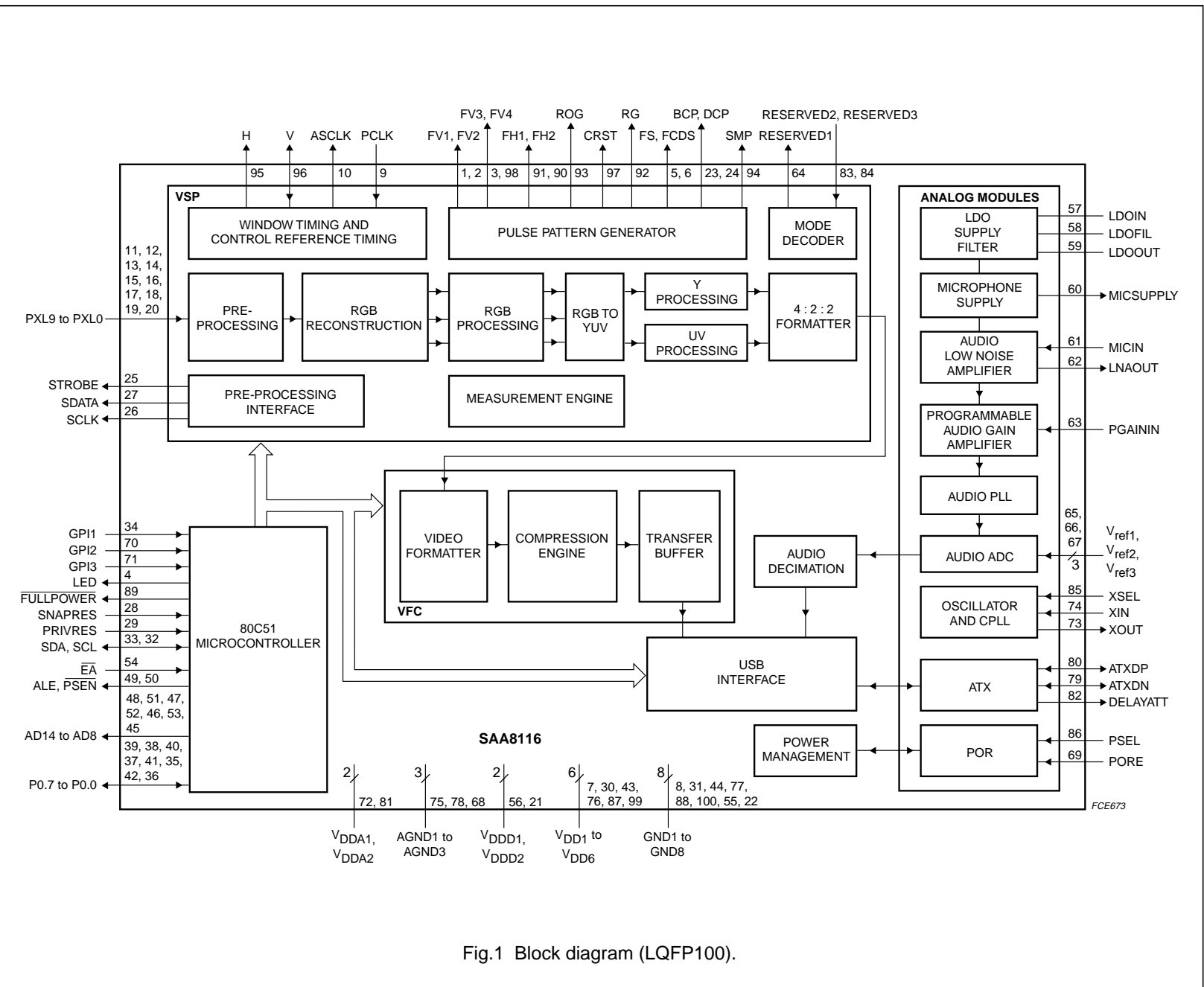

Fig.1 Block diagram (LQFP100).

Digital PC-camera signal processor including microcontroller and USB interface

SAA8116

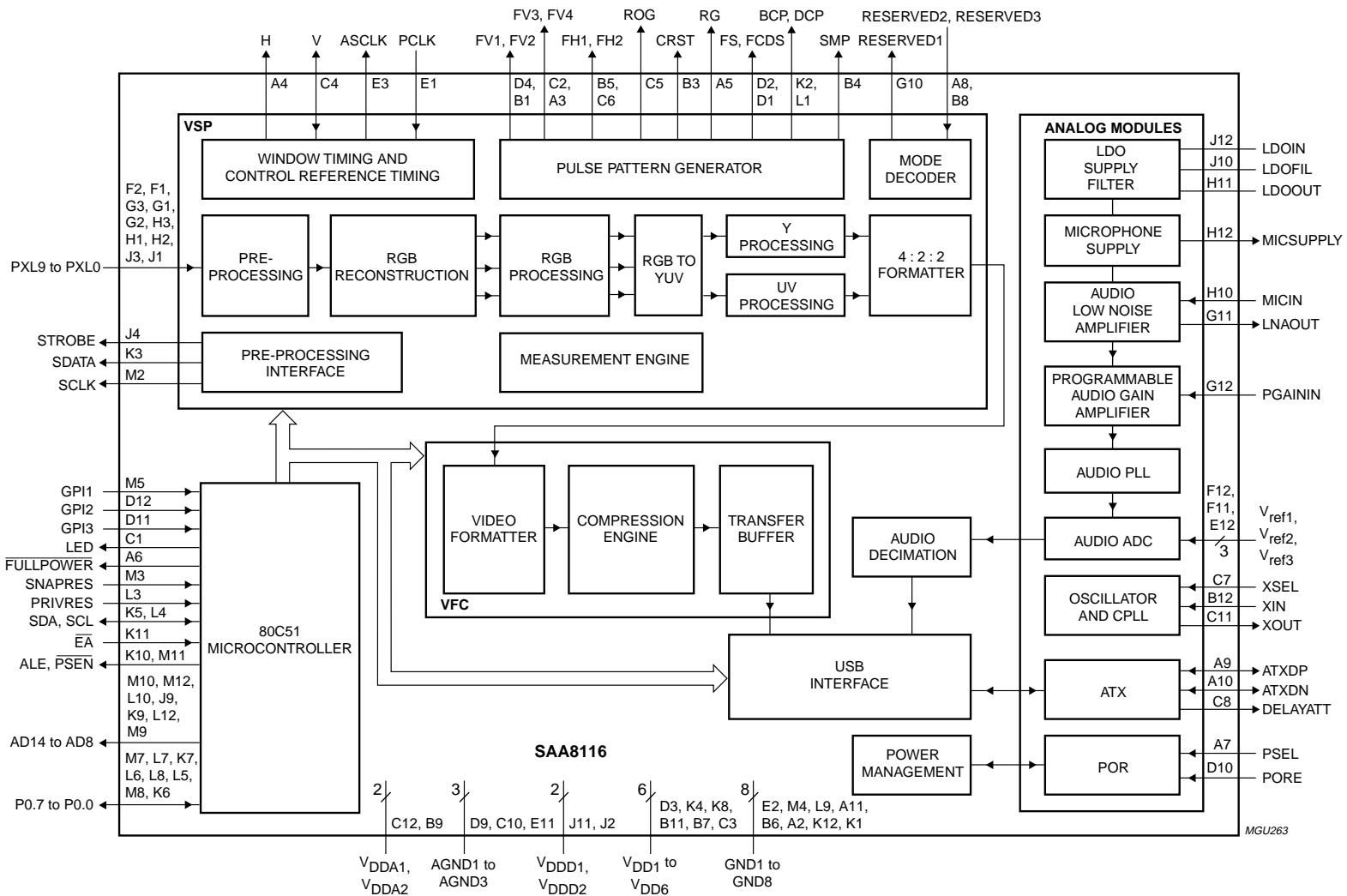

Fig.2 Block diagram (TFBGA112).

# Digital PC-camera signal processor including microcontroller and USB interface

SAA8116

## PINNING

SYMBOL	PIN <sup>(1)</sup>	BALL <sup>(2)</sup>	TYPE <sup>(3)</sup>	DESCRIPTION
FV1	1	D4	O	vertical CCD transfer pulse output (or general purpose output)
FV2	2	B1	O	vertical CCD transfer pulse output (or general purpose output)
FV3	3	C2	O	vertical CCD transfer pulse output (or general purpose output)
LED	4	C1	O	output to drive LED
FS	5	D2	O	data sample-and-hold pulse output to TDA8787A (SHD)
FCDS	6	D1	O	preset sample-and-hold pulse output to TDA8787A (SHP)
V <sub>DD1</sub>	7	D3	P	supply voltage 1 for output buffers
GND1	8	E2	P	ground 1 for output buffers
PCLK	9	E1	I	pixel input clock
ASCLK	10	E3	O	clock 1 (pixel clock) or clock 2 (2 × pixel clock) output for ADC or CMOS sensor
PXL9	11	F2	I	pixel data input; bit 9
PXL8	12	F1	I	pixel data input; bit 8
PXL7	13	G3	I	pixel data input; bit 7
PXL6	14	G1	I	pixel data input; bit 6
PXL5	15	G2	I	pixel data input; bit 5
PXL4	16	H3	I	pixel data input; bit 4
PXL3	17	H1	I	pixel data input; bit 3
PXL2	18	H2	I	pixel data input; bit 2
PXL1	19	J3	I	pixel data input; bit 1
PXL0	20	J1	I	pixel data input; bit 0
V <sub>DD2</sub>	21	J2	P	supply voltage 2 for the digital core
GND8	22	K1	P	ground 8 for input buffers and predrivers
BCP	23	K2	O	optical black clamp pulse output to TDA8787A
DCP	24	L1	O	dummy clamp pulse output to TDA8787A
STROBE	25	J4	O	strobe signal output to TDA8787A or general purpose output of the microcontroller
SCLK	26	M2	O	serial clock output to TDA8787A or general purpose output of the microcontroller
SDATA	27	K3	O	serial data output to TDA8787A or general purpose output of the microcontroller
SNAPRES	28	M3	I	snapshot input or remote wake-up trigger input (programmable)
PRIVRES	29	L3	I	privacy shutter input or remote wake-up trigger input (programmable)
V <sub>DD2</sub>	30	K4	P	supply voltage 2 for input buffers and predrivers
GND2	31	M4	P	ground 2 for input buffers and predrivers
SCL	32	L4	I/O	I <sup>2</sup> C-bus clock input/output (master/slave)
SDA	33	K5	I/O	I <sup>2</sup> C-bus data input/output (master/slave)
GPI1	34	M5	I	general purpose input 1 (Port 4; bit 6)
P0.2	35	L5	I/O	microcontroller Port 0 bidirectional (data - address); bit 2
P0.0	36	K6	I/O	microcontroller Port 0 bidirectional (data - address); bit 0

# Digital PC-camera signal processor including microcontroller and USB interface

SAA8116

SYMBOL	PIN <sup>(1)</sup>	BALL <sup>(2)</sup>	TYPE <sup>(3)</sup>	DESCRIPTION
P0.4	37	L6	I/O	microcontroller Port 0 bidirectional (data - address); bit 4
P0.6	38	L7	I/O	microcontroller Port 0 bidirectional (data - address); bit 6
P0.7	39	M7	I/O	microcontroller Port 0 bidirectional (data - address); bit 7
P0.5	40	K7	I/O	microcontroller Port 0 bidirectional (data - address); bit 5
P0.3	41	L8	I/O	microcontroller Port 0 bidirectional (data - address); bit 3
P0.1	42	M8	I/O	microcontroller Port 0 bidirectional (data - address); bit 1
V <sub>DD3</sub>	43	K8	P	supply voltage 3 for output buffers
GND3	44	L9	P	ground 3 for output buffers
AD8	45	M9	O	microcontroller Port 2 output (address); bit 0
AD10	46	K9	O	microcontroller Port 2 output (address); bit 2
AD12	47	L10	O	microcontroller Port 2 output (address); bit 4
AD14	48	M10	O	microcontroller Port 2 output (address); bit 6
ALE	49	K10	O	address latch enable output for external latch
PSEN	50	M11	O	program store enable output for external memory (active LOW)
AD13	51	M12	O	microcontroller Port 2 output (address); bit 5
AD11	52	J9	O	microcontroller Port 2 output (address); bit 3
AD9	53	L12	O	microcontroller Port 2 output (address); bit 1
EA	54	K11	I	external access select input; internal (HIGH) or external (LOW) program memory
GND7	55	K12	P	ground 7 for input buffers and predrivers
V <sub>DDD1</sub>	56	J11	P	supply voltage 1 for the digital core
LDOIN	57	J12	P	analog supply voltage for LDO supply filter
LDOFIL	58	J10	–	external capacitor connection (filter of LDO)
LDOOUT	59	H11	–	external capacitor connection (internal analog supply voltage for PLL; amplifier and ADC)
MICSUPPLY	60	H12	O	microphone supply output
MICIN	61	H10	I	microphone input
LNAOUT	62	G11	O	low noise amplifier output
PGAININ	63	G12	I	programmable gain amplifier input
RESERVED1	64	G10	O	test pin 1 (should be floating)
V <sub>ref1</sub>	65	F12	I	reference voltage 1 (used in the amplifier and the ADC)
V <sub>ref2</sub>	66	F11	I	reference voltage 2 (used in the ADC)
V <sub>ref3</sub>	67	E12	I	reference voltage 3 (used in the ADC)
AGND3	68	E11	P	analog ground 3 for PLL; amplifier and ADC
PORE	69	D10	I	external Power-on reset
GPI2	70	D12	I	general purpose input 2 (Port 1; bit 4)
GPI3	71	D11	I	general purpose input 3 (Port 3; bit 5)
V <sub>DDA1</sub>	72	C12	P	analog supply voltage for crystal oscillator (12 MHz, fundamental)
XOUT	73	C11	O	oscillator output
XIN	74	B12	I	oscillator input
AGND1	75	D9	P	analog ground 1 for crystal oscillator

# Digital PC-camera signal processor including microcontroller and USB interface

SAA8116

SYMBOL	PIN <sup>(1)</sup>	BALL <sup>(2)</sup>	TYPE <sup>(3)</sup>	DESCRIPTION
V <sub>DD4</sub>	76	B11	P	supply voltage 4 for input buffers and predrivers
GND4	77	A11	P	ground 4 for input buffers and predrivers
AGND2	78	C10	P	analog ground 2 for ATX transceiver
ATXDN	79	A10	I/O	negative driver of the differential data pair input/output (ATX)
ATXDP	80	A9	I/O	positive driver of the differential data pair input/output (ATX)
V <sub>DDA2</sub>	81	B9	P	analog supply voltage 2 for ATX transceiver
DELAYATT	82	C8	O	delayed attach control output; connected with pull-up resistor on ATXDP (USB)
RESERVED2	83	A8	I	test pin 2 (should be connected to GND)
RESERVED3	84	B8	I	test pin 3 (should be connected to GND)
XSEL	85	C7	I	crystal selection input
PSEL	86	A7	I	POR selection input
V <sub>DD5</sub>	87	B7	P	supply voltage 5 for output buffers
GND5	88	B6	P	ground 5 for output buffers
FULLPOWER	89	A6	O	full power signal output (active LOW)
FH2	90	C6	O	horizontal CCD transfer pulse output
FH1	91	B5	O	horizontal CCD transfer pulse output
RG	92	A5	O	reset output for CCD output amplifier gate
ROG	93	C5	O	vertical CCD load pulse output
SMP	94	B4	O	switch mode pulse output for CCD supply
H	95	A4	O	horizontal synchronization pulse output
V	96	C4	I/O	vertical synchronization pulse input/output
CRST	97	B3	O	CCD charge reset output for shutter control
FV4	98	A3	O	vertical CCD transfer pulse output
V <sub>DD6</sub>	99	C3	P	supply voltage 6 for output buffers
GND6	100	A2	P	ground 6 for output buffers

## Notes

1. Pinning related to LQFP100 package.
2. Pinning related to TFBGA112 package.
3. I = input; O = output and P = power supply.



Digital PC-camera signal processor including microcontroller and USB interface

SAA8116

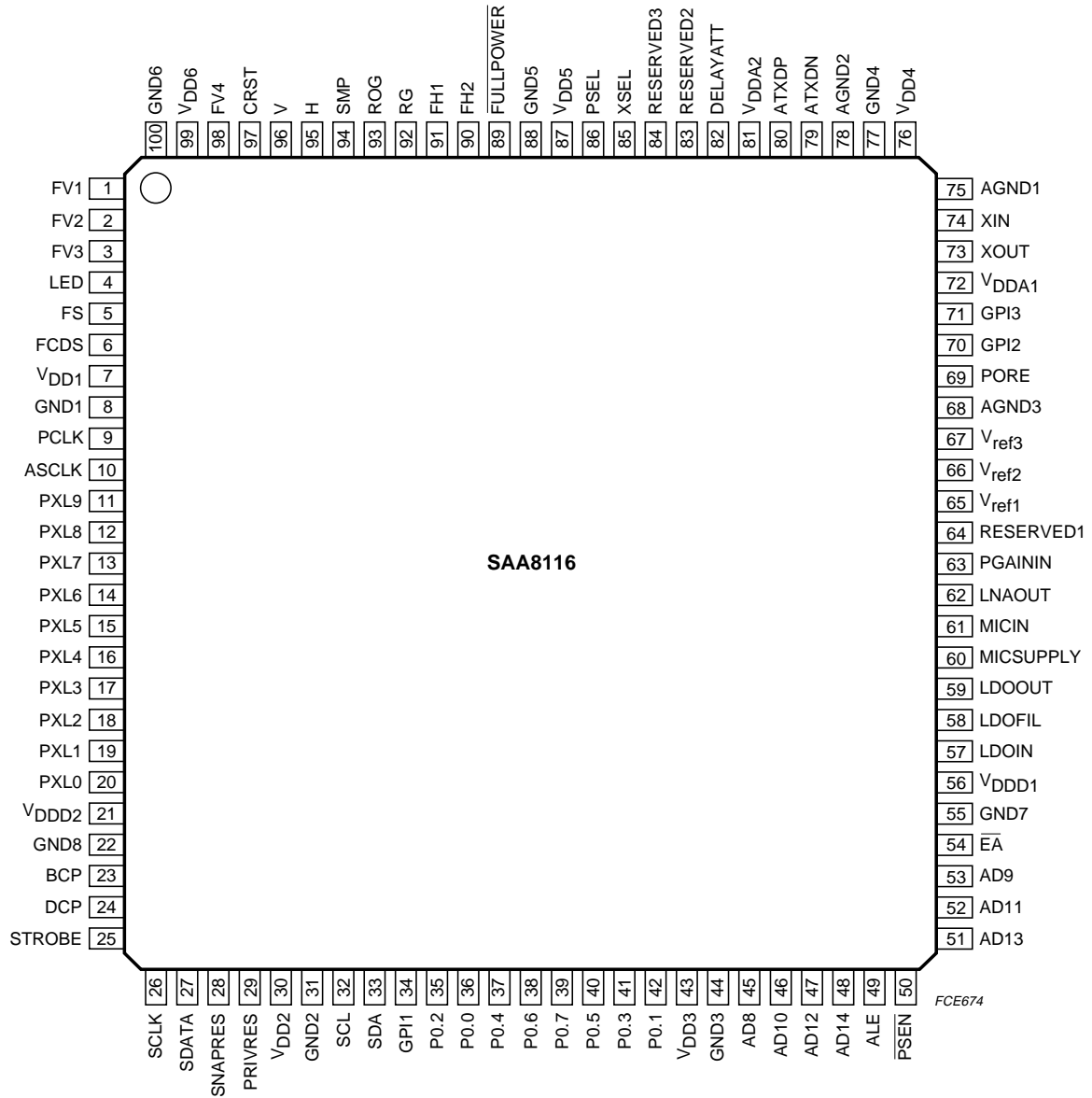

Fig.3 Pin configuration (LQFP100).

Digital PC-camera signal processor including  
microcontroller and USB interface

SAA8116

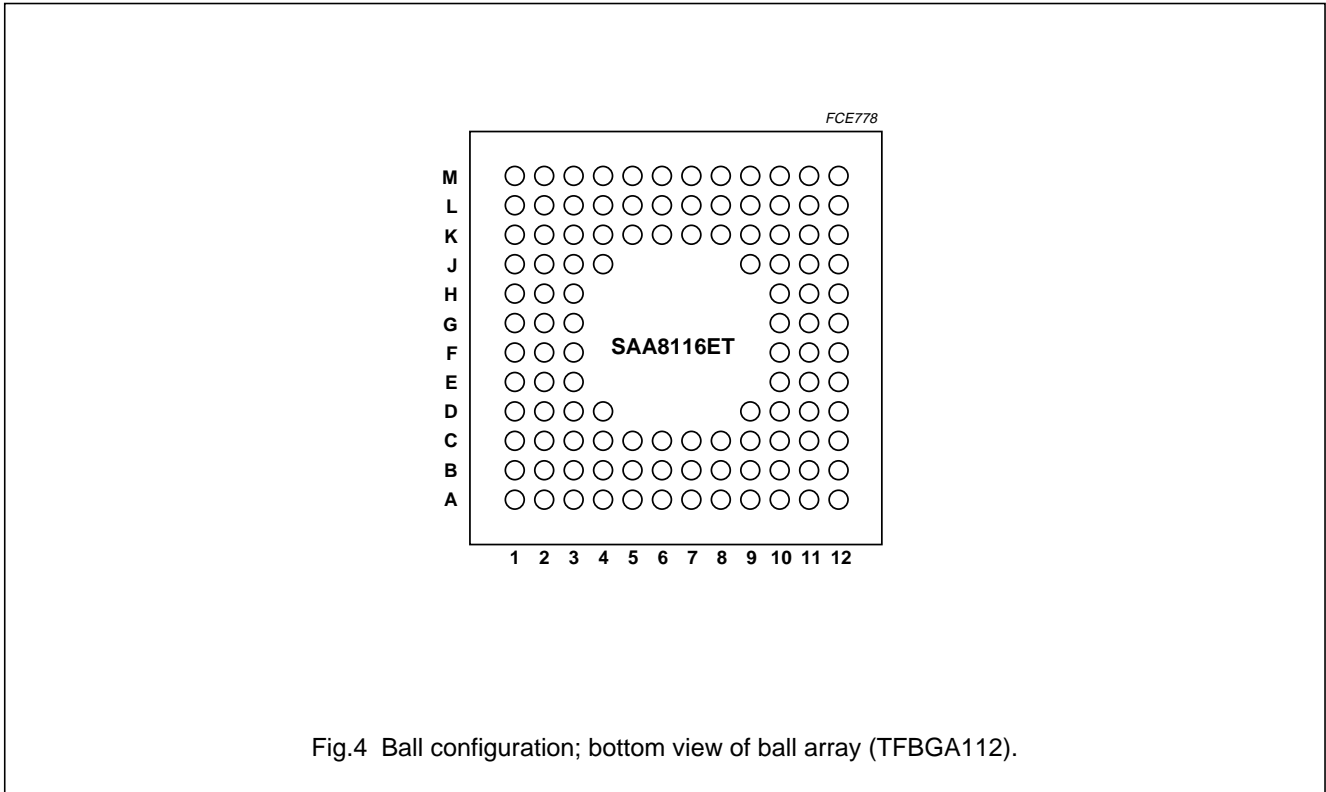

Fig.4 Ball configuration; bottom view of ball array (TFBGA112).

# Digital PC-camera signal processor including microcontroller and USB interface

SAA8116

## Pinning for TFBGA112

BALL	SYMBOL
A1	n.c.
A2	GND6
A3	FV4
A4	H
A5	RG
A6	FULLPOWER
A7	PSEL
A8	RESERVED2
A9	ATXDP
A10	ATXDN
A11	GND4
A12	n.c.
B1	FV2
B2	n.c.
B3	CRST
B4	SMP
B5	FH1
B6	GND5
B7	V <sub>DD5</sub>
B8	RESERVED3
B9	V <sub>DDA2</sub>
B10	n.c.
B11	V <sub>DD4</sub>
B12	XIN
C1	LED
C2	FV3
C3	V <sub>DD6</sub>
C4	V
C5	ROG
C6	FH2
C7	XSEL
C8	DELAYATT
C9	n.c.
C10	AGND2
C11	XOUT
C12	V <sub>DDA1</sub>
D1	FCDS

BALL	SYMBOL
D2	FS
D3	V <sub>DD1</sub>
D4	FV1
D9	AGND1
D10	PORE
D11	GPI3
D12	GPI2
E1	PCLK
E2	GND1
E3	ASCLK
E10	n.c.
E11	AGND3
E12	V <sub>ref3</sub>
F1	PXL8
F2	PXL9
F3	n.c.
F10	n.c.
F11	V <sub>ref2</sub>
F12	V <sub>ref1</sub>
G1	PXL6
G2	PXL5
G3	PXL7
G10	RESERVED1
G11	LNAOUT
G12	PGAININ
H1	PXL3
H2	PXL2
H3	PXL4
H10	MICIN
H11	LDOOUT
H12	MICSUPPLY
J1	PXL0
J2	V <sub>DD2</sub>
J3	PXL1
J4	STROBE
J9	AD11
J10	LDOFIL
J11	V <sub>DD1</sub>

BALL	SYMBOL
J12	LDOIN
K1	GND8
K2	BCP
K3	SDATA
K4	V <sub>DD2</sub>
K5	SDA
K6	P0.0
K7	P0.5
K8	V <sub>DD3</sub>
K9	AD10
K10	ALE
K11	EA
K12	GND7
L1	DCP
L2	n.c.
L3	PRIVRES
L4	SCL
L5	P0.2
L6	P0.4
L7	P0.6
L8	P0.3
L9	GND3
L10	AD12
L11	n.c.
L12	AD9
M1	n.c.
M2	SCLK
M3	SNAPRES
M4	GND2
M5	GPI1
M6	n.c.
M7	P0.7
M8	P0.1
M9	AD8
M10	AD14
M11	PSEN
M12	AD13

## Digital PC-camera signal processor including microcontroller and USB interface

SAA8116

### FUNCTIONAL DESCRIPTION

The SAA8116 video processor has a very high level of programmability: 118 (8-bit) registers are dedicated for the Video Signal Processor (VSP), including Pulse Pattern Generator (PPG) and Measurement Engine (ME), plus 23 registers for the Video Formatter and Compressor (VFC). The SAA8116 can accept 8 to 10-bit digital data from various VGA sensors: CCD (progressive) or CMOS, with or without colour filters (see Table 1).

### Synchronization and video windows

#### CCD SENSOR PULSE PATTERN GENERATOR

The SAA8116 incorporates a PPG function, which can be used for VGA CCD sensors, see Table 1.

Depending on the sensor type, an external inverter driver is required to convert the 3.3 V pulses to a voltage suitable for the CCD sensor used.

The active video size is 640 × 480 for VGA. The total H × V size is 823 × 486 for VGA.

A total of 19 internal registers make a high level of flexibility available for the PPG.

#### FLEXIBLE HV TIMING

The PPG module is not used with CMOS sensors. The SAA8116 provides some flexibility on the frame size to increase the range of applicable sensors (see Table 1). It is possible to program the position, width and polarity of the H and V signals. The output clock for the CMOS sensor is selectable between single and double pixel clock, including a programmable polarity.

The HV timing module can serve both as master or slave. When serving as a slave, the V pulse only is needed since the H pulse is internally derived from V by programming the number of pixels per line.

#### VIDEO WINDOWS

Several registers allow the definition of the optical black window, the active video input window, the active video output window and the measurement windows.

**Table 1** Typical SAA8116 compatible sensors

SENSOR TYPE	BRAND	PART NUMBER
VGA CCD	Sony	ICX098AK
	Panasonic	MN37771PT
	Sharp	LZ24BP
VGA CMOS	Philips	UPA1021
	Hyundai	HV7131B
	Photobit	PB-0320
Other sensors	all sensors that fulfil the following criteria: <ul style="list-style-type: none"> <li>• B and W; RGB Bayer colour filter</li> <li>• 8-bit, 9-bit or 10-bit output</li> <li>• CMOS or CCD sensors</li> <li>• progressive</li> </ul>	

# Digital PC-camera signal processor including microcontroller and USB interface

SAA8116

## Video signal processor

### OPTICAL BLACK PROCESSING

The first processing block of the SAA8116 is a digital clamp (denoted as PRE-PROCESSING in Fig.1). It is used to align the optical black level to zero or to any arbitrary value.

The average value of the black is measured in the programmable optical black window and sent to the microcontroller for adjustment, if necessary. The value fixed by the microcontroller is subtracted from the incoming data stream.

The optical black window has a fixed size of 16 pixels (horizontally) by 128 (vertically); the position of this window is fully programmable.

Each of the four colour filter inputs has its own offset and gain.

### DEFECT PIXEL CONCEALMENT

Up to 128 Defect Pixel Coordinates (DPC) can be taken into account for concealment. The method is based either on a horizontal linear interpolation, or on a copy of a neighbouring pixel of the same colour.

### RGB COLOUR RECONSTRUCTOR

In the RGB colour reconstructor (denoted as RGB RECONSTRUCTION in Fig.1), an RGB triplet is interpolated for every pixel on a 3 × 3 neighbourhood matrix.

With B and W sensors, the RGB colour reconstructor can be disabled, thus maintaining the full sensor resolution.

Vertical contours and video level information (white clip) are extracted at this stage (see Fig.5).

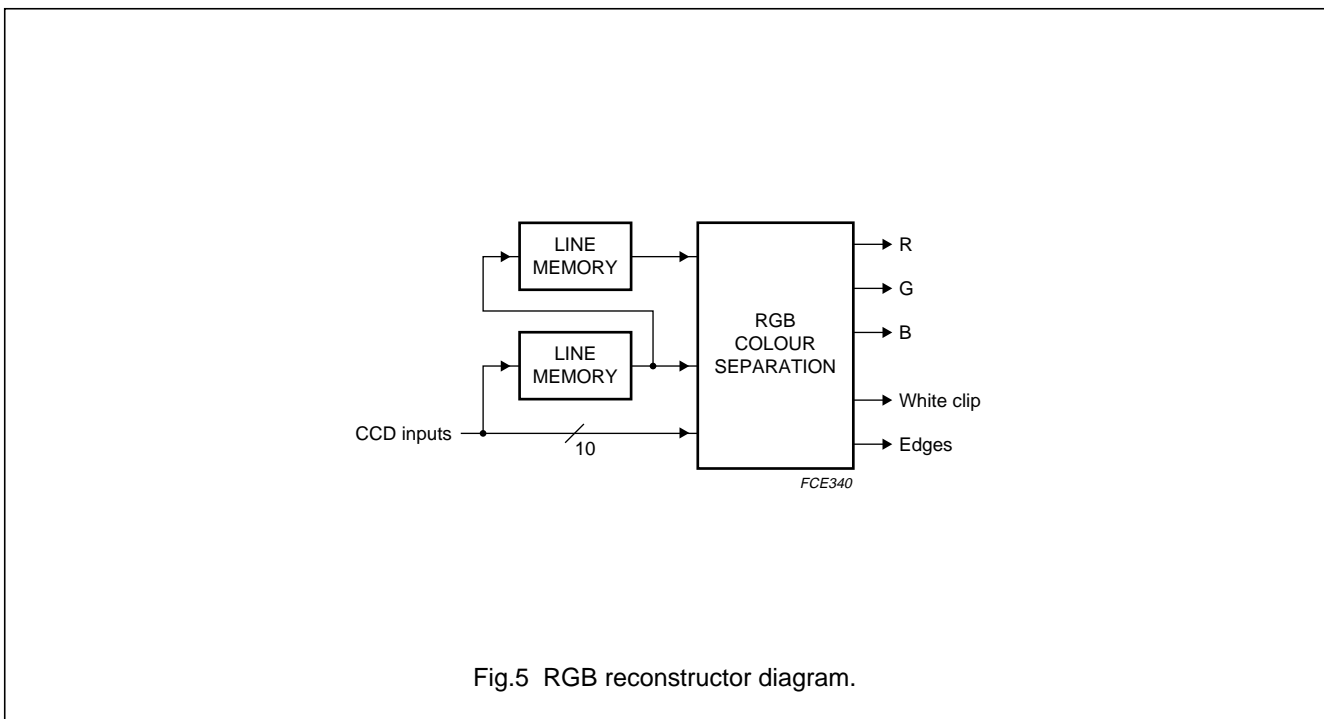

Fig.5 RGB reconstructor diagram.

# Digital PC-camera signal processor including microcontroller and USB interface

SAA8116

## COLOUR MATRIX

A programmable  $3 \times 3$  colour matrix (see Fig.6) is used to convert the extracted colour information, R, G and B from the sensor colour space to a standard RGB colour space.

With B and W sensors, a unity matrix is used.

To control the white balance, the gain of the red and blue stream can be changed.

Gamma and knee are combined in one function with adjustable gain.

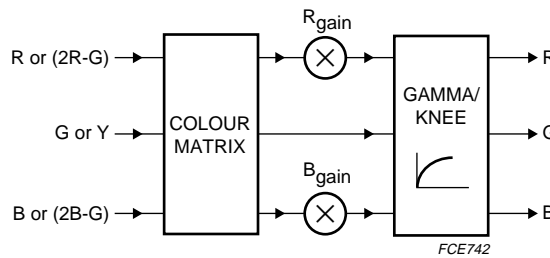

Fig.6 RGB processing diagram.

## YUV PROCESSING

Following the RGB processing, the R, G and B signals are converted to YUV 4 : 2 : 2 by a fixed matrix (see Fig.7). Then, the luminance and chrominance signals are processed separately.

The luminance processing consists of edge enhancement. This feature is very flexible. First, it is possible to adjust the bandwidth and the level of the edge detection. Secondly, the amount of edge enhancement can be independently adjusted for the horizontal or vertical edge or for the high or low frequency edge.

The chrominance processing consists of a colour killer (white clip) and a UV gain control (see Fig.8). Processing is done on the multiplexed two-times-downsampled UV chrominance signals. The sensor input is used to kill the colour of over-exposed pixels. It is possible to adjust the number of pixels on which the correction is applied.

The YUV processing block concludes with separate gain controls on the Y, U and V signals. These gains can be used to fine tune the Y, U and V colour balance and also to adjust the luminance and saturation without disturbing the AE and AWB control loops.

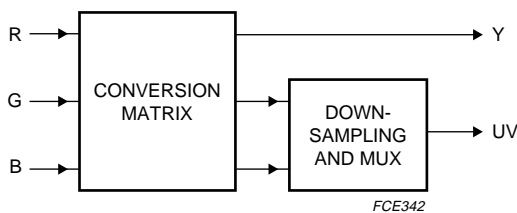

Fig.7 RGB to YUV conversion.

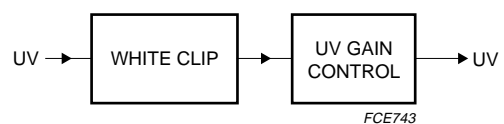

Fig.8 UV processing.

# Digital PC-camera signal processor including microcontroller and USB interface

SAA8116

## MEASUREMENT ENGINE

The ME extracts statistical information from the video stream. These measurements are used for the auto-control loops in the microcontroller (AWB, AE and AGC). They can also be used for other purposes, such as colour detection. The measurements are performed on pre-formatted Y, U and V streams. It is possible to measure the accumulated value of the Y, U or V samples either in the full active video window or in a simple programmable window.

Five parallel measurements of the luminance can be done for the auto exposure, each based on a proper window. Y, U and V can be measured independently for the auto white balance, all based on the same window.

During each frame, the microcontroller has access to the measured values of the previous frame.

## Video formatter

This block is used to convert the YUV 4 : 2 : 2 format to 4 : 2 : 0 required by the compression engine. The incoming 4 : 2 : 2 data is vertically filtered. In raw mode, this block is bypassed to create a full resolution snapshot.

The formatter can also perform downscaling to SIF and QSIF (see Table 2).

To avoid aliasing, this formatter also contains horizontal and vertical low pass pre-filters before downscaling.

**Table 2** Scaler modes

SENSOR TYPE	OUTPUT FORMAT	SCALER MODES
VGA	SIF 320 × 240	scaled half horizontally and vertically
	QSIF 160 × 120	scaled quarter horizontally and vertically

## Compression engine

The compression engine module (see Fig.9) can process VGA, SIF and QSIF, based on a Philips proprietary algorithm. The compression ratio is continuously programmable by setting a maximum bit cost limit. Input data can also be a raw RGB sensor data to perform optimum snapshot processing in the host software.

The compression engine uses several strategies and Q-tables for optimum performance at a wide range of compression ratios (up to 8×). The required table must be selected via software. One table is optimized for compressing the raw VGA data.

Real time decoding can be done in software on any Pentium™ or AMD-K6 platform.

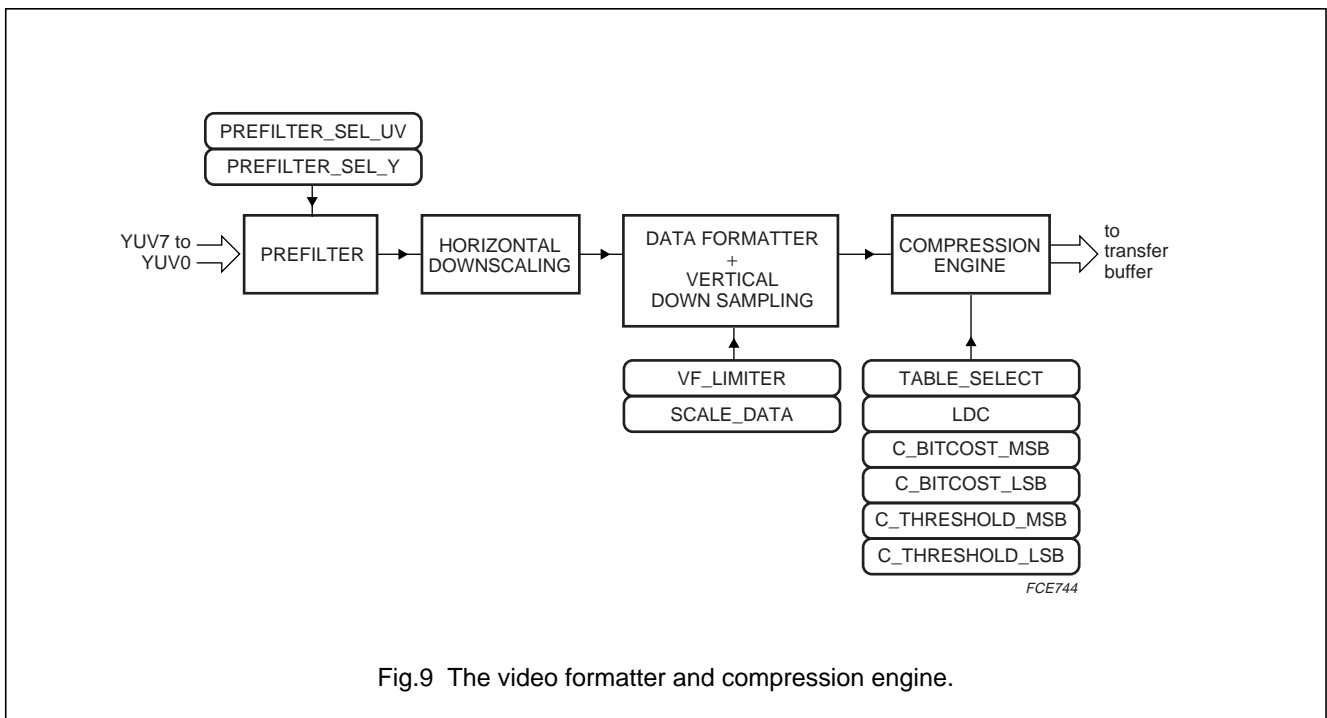

Fig.9 The video formatter and compression engine.

## Digital PC-camera signal processor including microcontroller and USB interface

SAA8116

Table 3 gives the available output formats and frame rates.

**Table 3** Video formats

FORMAT	FRAME RATE	COMPRESSION MODE
VGA	5	raw; compressed
	5	compressed
	10	compressed
	15	compressed
	30	compressed
SIF	5	compressed and uncompressed
	10	compressed
	15	compressed
	20	compressed
	24	compressed
	30	compressed
QSIF	5	compressed and uncompressed
	10	compressed and uncompressed
	15	compressed and uncompressed
	20	compressed and uncompressed
	24	compressed and uncompressed
	30	compressed and uncompressed

The compressed data is streamed into a video FIFO, ready to be packed into USB formatted data blocks.



## Digital PC-camera signal processor including microcontroller and USB interface

SAA8116

### Universal serial bus 1.1 core

The USB core combines all functionalities for a USB 1.1 compliant full speed device. It formats the actual packets (video and audio) that are transferred to the USB and passes the incoming packets to the right end-point buffer. The end-point setup is composed of control, generic and isochronous types (see Table 4). All end-points can be enabled or disabled, except control end-points.

All enabled end-points generate interrupts to the embedded microcontroller when they need to be serviced. The microcontroller can then use a set of commands via the internal parallel interface.

The video FIFO size allows demarcation of the video frames using one or more 0-length packets.

The core also includes VID class support for the video end-point: headers and trailers enable data to be attached to the video frames that are passed over the USB. Eight 1-byte registers are dedicated for the headers, while four registers comprise the trailers. Each of the registers can be programmed by the microcontroller. An extra register, TR\_HT\_CONTROL, specifies how many bytes are inserted before or after the video data.

**Table 4** Mapping of logical to physical end-point numbers for the end-points

LOGICAL END-POINT	PHYSICAL END-POINT	END-POINT TYPE	DIRECTION	BUFFER SIZE	DOUBLE BUFFERED
0	0	control	out	16	no
	1	control	in	16	no
1	2	generic	out	8	no
	3	generic	in	8	no
2	4	generic	in	8	no
3	5	generic	in	8	no
4	6	isochronous	in	92	yes
5	7	isochronous	in	programmable	multi-buffered

### ATX interface

The SAA8116 contains an analog bus driver, called the ATX. This driver incorporates a differential amplifier and two single-ended buffers for the receiver part and two single-ended buffers for the transmitter part.

The interface to the bus consists of a differential data pair (ATXDN and ATXDP).

### Microcontroller

The embedded microcontroller is an 80C654 core (80C51 family). Ports P0 and P2 (plus ALE and PSEN) are available for connection to an emulator or to an external program EPROM (32 kbytes max.).

The microcontroller can control the AOB, AE and AWB loops, and can download the settings for the internal registers from an optional EEPROM at power-up or reset.

A parallel interface is used to communicate with all internal modules, based on the MOVX@DPTR instruction.

The microcontroller includes the following features:

- 32 kbytes internal ROM
- 512 bytes RAM
- Hardware multi-master I<sup>2</sup>C-bus interface (the microcontroller can be used either as slave or master): P1.7 and P1.6
- Power-down mode
- Two timers
- P0 and P2 are pull-up ports
- Three pins are available as general purpose inputs: GPI1 (P4.6), GPI2 (P1.4) and GPI3 (P3.5).

# Digital PC-camera signal processor including microcontroller and USB interface

SAA8116

**Table 5** 80C51 Special Function Registers (SFR)

SFR NAME	DESCRIPTION	SFR ADDRESS	DATA BIT							
			7	6	5	4	3	2	1	0
B	B register	F0H	B7	B6	B5	B4	B3	B2	B1	B0
ACC	accumulator	E0H	ACC7	ACC6	ACC5	ACC4	ACC3	ACC2	ACC1	ACC0
SIADR	serial interface address	DBH	SA6	SA5	SA4	SA3	SA2	SA1	SA0	GC
SIDAT	serial interface data	DAH	SD7	SD6	SD5	SD4	SD3	SD2	SD1	SD0
SISTA	serial interface status	D9H	ST7	ST6	ST5	ST4	ST3	0	0	0
SICON	serial interface control	D8H	CR2	ENS1	STA	STO	SI	AA	CR1	CR0
PSW	program status word	D0H	CY	AC	F0	RS1	RS0	OV	–	P
P4	Port 4	C0H	P4.7	P4.6	P4.5	P4.4	P4.3	P4.2	P4.1	P4.0
IP	interrupt priority	B8H	–	IP6	IP5	IP4	PT1	PX1	PT0	PX0
P3	Port 3	B0H	$\overline{RD}$	$\overline{WR}$	T1	T0	INT1	INT0	TXD	RXD
IE	interrupt enable	A8H	$\overline{EA}$	IE6	IE5	IE4	ET1	EX1	ET0	EX0
P2	Port 2	A0H	(AD15)	AD14	AD13	AD12	AD11	AD10	AD9	AD8
SBUF	serial data buffer	99H	–	–	–	–	–	–	–	–
SCON	serial controller	98H	SM0	SM1	SM2	REN	TB8	RB8	T1	R1
P1	Port 1	90H	SDA	SCL	P1.5	P1.4	P1.3	P1.2	P1.1	P1.0
TH1	timer high 1	8DH	–	–	–	–	–	–	–	–
TH0	timer high 0	8CH	–	–	–	–	–	–	–	–
TL1	timer low 1	8BH	–	–	–	–	–	–	–	–
TL0	timer low 0	8AH	–	–	–	–	–	–	–	–
TMOD	timer mode	89H	GATE	C/T	M1	M0	GATE	C/T	M1	M0
TCON	timer control	88H	TF1	TR1	TF0	TR0	IE1	IT1	IE0	IT0
PCON	power control	87H	–	–	–	–	–	–	PD	IDL
DPH	data pointer high	83H	–	–	–	–	–	–	–	–
DPLI	data pointer low	82H	–	–	–	–	–	–	–	–
SP	stack pointer	81H	SP7	SP6	SP5	SP4	SP3	SP2	SP1	SP0
P0	Port 0	80H	P0.7	P0.6	P0.5	P0.4	P0.3	P0.2	P0.1	P0.0

**Audio**

The SAA8116 contains a microphone supply, including a low-drop electronic supply filter, and an amplifier circuit composed of two stages: a Low Noise Amplifier (LNA) and a variable gain amplifier (VGA). The LNA has a fixed gain of 30 dB while the VGA can be programmed between 0 and 30 dB in steps of 2 dB. The frequency transfer characteristic of the audio path must be controlled via external high-pass or low-pass filters.

The PLL converts the 48 MHz to  $256f_s$  ( $f_s$  = audio sample frequency). There are three modes for the PLL to achieve the sample frequencies of 48, 44.1 and 32 kHz or their derivatives (see Table 6).

The bitstream ADC samples the mono audio signal. It runs at an oversample rate of 256 times the base sample rate. A decimator filter transforms the bitstream output to 16-bit samples.

A digital mute option is available.

## Digital PC-camera signal processor including microcontroller and USB interface

SAA8116

**Table 6** ADC clock frequencies and sample frequencies

CLOCK (MHz)	DIVIDING NUMBER	SAMPLE FREQUENCY (kHz)	ADC CLOCK (MHz)
8.1920	1	32	4.096
	2	16	2.048
	4	8	1.042
	8	note 1	note 1
11.2896	1	44.1	5.6448
	2	22.05	2.8224
	4	11.025	1.4112
	8	5.5125	0.7056
12.2880	1	48	6.144
	2	24	3.072
	4	12	1.536
	8	6	0.768

**Note**

1. Not supported.

**Power management**

USB requires the device to switch power states. The SAA8116 contains a power management module since the complete camera may not consume more than 500  $\mu$ A during the SUSPEND power state. This requires that even the crystal oscillator must be switched off. The SAA8116 is not functional except for some logic that enables the IC to wake up the camera.

The SAA8116 incorporates remote wake-up (on two pins) to signal the host to resume operation when triggered.

The power management module also sets a flag in register POWERMGT\_STATUS. After a reset, the microcontroller should check this register and find the cause of the wake-up. Different causes may require different start-up routines.

**Miscellaneous functions**

Some additional functions are integrated in the SAA8116 to provide a cost effective application.

**SERIAL INTERFACE WITH THE PRE-PROCESSOR**

With CCD image sensors, the pre-processor (e.g. TDA8787A) is controlled over a 3-wire serial interface. It is adapted to shift out 16 bit settings. For flexibility, the output pins can also be programmed as three general output pins using register PIN\_CONFIG\_1.

**CLOCK PLL**

The SAA8116 runs on an internal master clock of 48 MHz, which can be derived from either a 48 or 12 MHz fundamental crystal. When it is derived from a 12 MHz fundamental crystal, an internal clock PLL transfers the 12 MHz to 48 MHz, with a 50% duty cycle.

A 48 MHz third overtone crystal can also be used but requires an external LC circuit.

**RING OSCILLATOR**

To generate several time constants for power state switching, a digital counter running on an integrated ring oscillator is incorporated, thus saving pins and commonly used external RC components.

**POWER-ON RESET (POR)**

A POR function is integrated to generate a reset during the start-up of the power supply and during a power fail. It includes a fixed threshold detector (2.6 V) and a reset generator. The reset output has a built-in delay with a duration determined by the ring oscillator (around 100 ms).

An external POR can be used.

**MODE CONTROL**

Two pins are dedicated to control the operational modes of the SAA8116 (see Table 7).

**Table 7** Mode control

XS	PS	MODE
0	0	application mode (48 MHz crystal; internal POR)
0	1	application mode (48 MHz crystal; external POR)
1	0	application mode (12 MHz crystal; internal POR)
1	1	application mode (12 MHz crystal; external POR)

# Digital PC-camera signal processor including microcontroller and USB interface

SAA8116

## CONTROL REGISTER DESCRIPTION

This specification gives an overview of all internal registers. Several modules (VSP, VFC, PPG, USB, audio and power management) communicate with the internal microcontroller via a common parallel interface. The protocol is based on a standard MOVX@DPTR instruction. A relative address (DPH) is used to select one

of the modules (via Port 2), while register addresses and data are exchanged via Port 0.

### VSP, VFC and PPG registers

A first MOVX@DPTR instruction enables to select the module (via DPH) and the register address. A second one communicates the data (read or write).

**Table 8** Register list

ADDRESS	NAME	FUNCTION	FORMAT	RANGE
<b>Write registers</b>				
0	0x00H	VSP_CONTROL0	control register for VSP data path	see Table 9 n.a.
1	0x01H	VSP_CONTROL1	control register for VSP data path	see Table 10 n.a.
2	0x02H	OB_K1	fixed optical black level for K1 pixel	byte [-128 to 127]
3	0x03H	OB_K2	fixed optical black level for K2 pixel	byte [-128 to 127]
4	0x04H	OB_K3	fixed optical black level for K3 pixel	byte [-128 to 127]
5	0x05H	OB_K4	fixed optical black level for K4 pixel	byte [-128 to 127]
6	0x06H	PRE_MAT_K1	pre-gain for K1 pixel	byte
7	0x07H	PRE_MAT_K2	pre-gain for K2 pixel	byte
8	0x08H	PRE_MAT_K3	pre-gain for K3 pixel	byte
9	0x09H	PRE_MAT_K4	pre-gain for K4 pixel	byte
10	0x0AH	WHITE_CLIP_THR	threshold for white clip detector	byte 768 + [0 to 255]
11	0x0BH	reserved		
12	0x0CH	COL_MAT_P11	colour matrix coefficient p11	byte [-128 to 127]/16
13	0x0DH	COL_MAT_P12	colour matrix coefficient p12	byte [-128 to 127]/16
14	0x0EH	COL_MAT_P13	colour matrix coefficient p13	byte [-128 to 127]/16
15	0x0FH	COL_MAT_P21	colour matrix coefficient p21	byte [-128 to 127]/16
16	0x10H	COL_MAT_P22	colour matrix coefficient p22	byte [-128 to 127]/16
17	0x11H	COL_MAT_P23	colour matrix coefficient p23	byte [-128 to 127]/16
18	0x12H	COL_MAT_P31	colour matrix coefficient p31	byte [-128 to 127]/16
19	0x13H	COL_MAT_P32	colour matrix coefficient p32	byte [-128 to 127]/16
20	0x14H	COL_MAT_P33	colour matrix coefficient p33	byte [-128 to 127]/16
21	0x15H	COL_MAT_RGAIN	red gain for white balance correction	byte [0 to 255]/128
22	0x16H	COL_MAT_BGAIN	blue gain for white balance correction	byte [0 to 255]/64
23	0x17H	GAMMA_KNEE	control of gamma/knee level	see Table 11 n.a.
24	0x18H	VC_CNTRL	vertical contour control	see Table 12 n.a.
25	0x19H	CLDLEV	contour level dependency level	byte [0 to 255]/2

# Digital PC-camera signal processor including microcontroller and USB interface

SAA8116

ADDRESS		NAME	FUNCTION	FORMAT	RANGE
26	0x1AH	HCLGAIN/HCHGAIN	horizontal contour BPF low gain (MS)/horizontal contour BP high gain (LS)	nibble	[0 to 15]/16
27	0x1BH	CNCLEV	contour noise coring level	6 bits	[0 to 63]/2
28	0x1CH	CONGAIN	contour gain factor	6 bits	[0 to 63]/16
29	0x1DH	YGAIN	Y gain factor (luminance)	byte	[0 to 255]/128
30	0x1EH	UGAIN	U (B - Y) gain factor	byte	[0 to 255]/128
31	0x1FH	VGAIN	V (R - Y) gain factor	byte	[0 to 255]/128
32	0x20H	AWB_A	AWB_A (ME)	byte	[-128 to 127]/128
33	0x21H	AWB_B	AWB_B (ME)	byte	[-128 to 127]/128
34	0x22H	AWB_C	AWB_C (ME)	byte	[-128 to 127]/128
35	0x23H	AWB_D	AWB_D (ME)	byte	[-128 to 127]/128
36	0x24H	AWB_E	AWB_E (ME)	byte	[0 to 255]
37	0x25H	AWB_F	AWB_F (ME)	byte	[0 to 255]
38	0x26H	reserved			
39	0x27H	DMWSEL	display measurement window select	see Table 13	n.a.
40	0x28H	DISPLEV	display level in use with several display functions	see Table 14	n.a.
41	0x29H	DIG_SETUP	setup in digital output	byte	[0 to 255]
42	0x2AH	PRE_SI_LSB	control data (LS byte) for analog processing	byte	[0 to 255]
43	0x2BH	PRE_SI_MSB	control data (MS byte) for analog processing	byte	[0 to 255]
44	0x2CH	PIXCNT_PRESET_LSB	preset value of pixel counter (by default = 0)	byte	[0 to 255]
45	0x2DH	NLINE_PRESET_MSB	number of lines per frame + MSBs of preset register (by default = 6)	see Table 15	n.a.
46	0x2EH	LINECNT_PRESET_LSB	preset value for line counter; line number 0 is undefined (by default = 1)	byte	[1 to 255]
47	0x2FH	NPIX	number of pixels per line (by default = 55)	byte	768 + [0 to 255]
48	0x30H	CTR_UPD_LINE	number of line for double buffer update control registers	byte	1 + 2 × [0 to 255]
49	0x31H	OB_STARTLINE	first line optical black window	byte	2 × [0 to 255]
50	0x32H	OB_STARTPIXEL	first pixel optical black window	byte	4 × [0 to 255]
51	0x33H	PIX_START_ACTWIN_ME	starting position of the active window defining the ME windows (by default = 15)	4 bits	[0 to 15]
52	0x34H	HREFSTART	position of positive edge of HREF on a line (by default = 3)	4 bits	2 × [0 to 15]
53	0x35H	HOUT_PE_LSB	position of positive edge of HOUT	byte	[0 to 255]

# Digital PC-camera signal processor including microcontroller and USB interface

SAA8116

ADDRESS		NAME	FUNCTION	FORMAT	RANGE
54	0x36H	HOUT_NE_LSB	position of negative edge of HOUT	byte	[0 to 255]
55	0x37H	VOUT_HPE_LSB	horizontal position of positive edge of VOUT	byte	[0 to 255]
56	0x38H	VOUT_VPE_LSB	vertical position of positive edge of VOUT	byte	[0 to 255]
57	0x39H	VOUT_HNE_LSB	horizontal position of negative edge of VOUT	byte	[0 to 255]
58	0x3AH	VOUT_VNE_LSB	vertical position of negative edge of VOUT	byte	[0 to 255]
59	0x3BH	VHOUT_MSB_1	MSB of VHOUT position definitions (part 1)	see Table 16	n.a.
60	0x3CH	VHOUT_MSB_2	MSB of VHOUT position definitions (part 2)	see Table 17	n.a.
61	0x3DH	HOUTWIN_VPE_LSB	vertical position of positive edge of HOUT window	byte	[0 to 255]
62	0x3EH	HOUTWIN_VNE_LSB	vertical position of negative edge of HOUT window	byte	[0 to 255]
63	0x3FH	XSEL	selects the number of extended active pixels (by default = 0)	see Table 18	n.a.
64	0x40H	ME_WIN_START_AWB	AWB_window (Vstart; Hstart)	byte	
65	0x41H	ME_WIN_STOP_AWB	AWB_window (Vstop; Hstop)	byte	
66	0x42H	ME_WIN_START_AE_0	AE_window no. 0 (Vstart; Hstart)	byte	
67	0x43H	ME_WIN_STOP_AE_0	AE_window no. 0 (Vstop; Hstop)	byte	
68	0x44H	ME_WIN_START_AE_1	AE_window no. 1 (Vstart; Hstart)	byte	
69	0x45H	ME_WIN_STOP_AE_1	AE_window no. 1 (Vstop; Hstop)	byte	
70	0x46H	ME_WIN_START_AE_2	AE_window no. 2 (Vstart; Hstart)	byte	
71	0x47H	ME_WIN_STOP_AE_2	AE_window no. 2 (Vstop; Hstop)	byte	
72	0x48H	ME_WIN_START_AE_3	AE_window no. 3 (Vstart; Hstart)	byte	
73	0x49H	ME_WIN_STOP_AE_3	AE_window no. 3 (Vstop; Hstop)	byte	
74	0x4AH	ME_WIN_START_AE_4	AE_window no. 4 (Vstart; Hstart)	byte	
75	0x4BH	ME_WIN_STOP_AE_4	AE_window no. 4 (Vstop; Hstop)	byte	
76	0x4CH	DPCRAMPTR	RAM write pointer for DPC RAM	byte	3 × [0 to 127]
77	0x4DH	DPCRAMDATA	RAM write data DPC RAM	byte	[0 to 255]
78	0x4EH	reserved			
79	0x4FH	reserved			
80	0x50H	TR_HEADER #0	data for header byte no. 0	byte	
81	0x51H	TR_HEADER #1	data for header byte no. 1	byte	
82	0x52H	TR_HEADER #2	data for header byte no. 2	byte	
83	0x53H	TR_HEADER #3	data for header byte no. 3	byte	
84	0x54H	TR_HEADER #4	data for header byte no. 4	byte	
85	0x55H	TR_HEADER #5	data for header byte no. 5	byte	
86	0x56H	TR_HEADER #6	data for header byte no. 6	byte	

# Digital PC-camera signal processor including microcontroller and USB interface

SAA8116

ADDRESS		NAME	FUNCTION	FORMAT	RANGE
87	0x57H	TR_HEADER #7	data for header byte no. 7	byte	
88	0x58H	TR_TRAILER #0	data for trailer byte no. 0	byte	
89	0x59H	TR_TRAILER #1	data for trailer byte no. 1	byte	
90	0x5AH	TR_TRAILER #2	data for trailer byte no. 2	byte	
91	0x5BH	TR_TRAILER #3	data for trailer byte no. 3	byte	
92	0x5CH	TR_HT_CONTROL	header trailer control	see Table 19	n.a.
93	0x5DH	SMP_PERIOD	SMP period in units $4 \times \text{clk48\_period}$	byte	1 + [0 to 255]
94	0x5EH	SMP_LOWTIME	SMP low time in units $4 \times \text{clk48\_period}$	byte	1 + [0 to 255]
95	0x5FH	reserved			
96	0x60H	PPG_CONTROL_0	PPG control register 0 (by default = 0)	see Table 20	n.a.
97	0x61H	PPG_CONTROL_1	PPG control register 1 (by default = 64)	see Table 21	n.a.
98	0x62H	PPG_H_CTRL	controls mode of FH1; FH2 and RG (by default = 0)	see Table 22	n.a.
99	0x63H	PPG_V_INV	controls inversion of vertical FV1; FV2; FV3; FV4 and ROG signals (by default = 0)	see Table 23	n.a.
100	0x64H	PPG_H_INV	controls inversion of horizontal signals (by default = 0)	see Table 24	n.a.
101	0x65H	PPG_MISC_INV	controls inversion of misc. signals and sets additional mode controls (by default = 0)	see Table 25	n.a.
102	0x66H	PPG_SHUTTERSPEED_V_LSB	shutter speed line number (by default = 0)	see Table 26	
103	0x67H	PPG_SHUTTERSPEED_H_LSB	shutter speed CRST start (by default = 0)	see Table 27	
104	0x68H	PPG_SHUTTERSPEED_MSB	MSB for shutter speed control (line number; CRST start) (by default = 0)	see Table 28	n.a.
105	0x69H	PPG_BCP_START_LSB	starting position control for BCP pulse (by default = 0)	see Table 29	
106	0x6AH	PPG_BCP_STOP_LSB	stopping position control for BCP pulse (by default = 0)	see Table 30	
107	0x6BH	PPG_DCP_START_LSB	starting position control for DCP pulse (by default = 0)	see Table 31	
108	0x6CH	PPG_DCP_STOP_LSB	stopping position control for DCP pulse (by default = 0)	see Table 32	
109	0x6DH	PPG_BCP_DCP_MSB	MSB for start/stopping position control for BCP/DCP pulses (by default = 0)	see Table 33	
110	0x6EH	PPG_ROG1_START_LSB	starting position control for ROG1 pulse (by default = 0)	see Table 34	

## Digital PC-camera signal processor including microcontroller and USB interface

SAA8116

ADDRESS	NAME	FUNCTION	FORMAT	RANGE
111	0x6FH	PPG_ROG1_STOP_LSB	stopping position control for ROG1 pulse (by default = 0)	see Table 35
112	0x70H	PPG_ROG2_START_LSB	starting position control for ROG2 pulse (by default = 0)	see Table 36
113	0x71H	PPG_ROG2_STOP_LSB	stopping position control for ROG2 pulse (by default = 0)	see Table 37
114	0x72H	PPG_ROG1_2_MSB	MSB for start/stopping position control for ROG1/2 pulses (by default = 0)	see Table 38
115	0x73H	VFC_CONTROL_0	control register for video formatter and compression module (by default = 1)	see Table 39 n.a.
116	0x74H	VFC_CONTROL_1	control register for video formatter and compression module (by default = 0)	see Table 40 n.a.
117	0x75H	VF_LIMITER	sets value for limiter output of video formatter (by default = 0)	byte [0 to 255]
118	0x76H	C_bitcost_MSB	bit cost for compression module (MSB) (by default = 0)	byte 28 × [0 to 255]
119	0x77H	C_bitcost_LSB	bit cost for compression module (LSB) (by default = 0)	byte [0 to 255]
120	0x78H	C_THRESHOLD_MSB	fixed length coding threshold for compression module (MSB) (by default = 0)	byte 28 × [0 to 255]
121	0x79H	C_THRESHOLD_LSB	fixed length coding threshold for compression module (LSB) (by default = 0)	byte [0 to 255]
122	0x7AH	TR_CONTROL	control register for transfer module (video processing) (by default = 0)	bit n.a.
123	0x7BH	VFC_VS_V_SHFT	V_shift of internal line counter w.r.t. the VS pulse (by default = 0)	3 bits [0 to 7]
124	0x7CH	reserved		
125	0x7DH	reserved		
126	0x7EH	PIN_CONFIG_0	control pin configuration	see Table 41 n.a.
127	0x7FH	PIN_CONFIG_1	control pin configuration	see Table 42 n.a.
<b>Read registers</b>				
192	0xC0H	ME_AWB_Y_MSB	MSB part of ME_AWB_Y	byte [0 to 31]
193	0xC1H	ME_AWB_U_MSB	MSB part of ME_AWB_U	byte [0 to 31]
194	0xC2H	ME_AWB_V_MSB	MSB part of ME_AWB_V	byte [0 to 31]
195	0xC3H	ME_AE_#0_MSB	MSB part of ME_AE_no. 0	byte [0 to 31]
196	0xC4H	ME_AE_#1_MSB	MSB part of ME_AE_no. 1	byte [0 to 31]
197	0xC5H	ME_AE_#2_MSB	MSB part of ME_AE_no. 2	byte [0 to 31]
198	0xC6H	ME_AE_#3_MSB	MSB part of ME_AE_no. 3	byte [0 to 31]
199	0xC7H	ME_AE_#4_MSB	MSB part of ME_AE_no. 4	byte [0 to 31]



Digital PC-camera signal processor including  
microcontroller and USB interface

SAA8116

ADDRESS	NAME	FUNCTION	FORMAT	RANGE	
200	0xC8H	ME_AWB_Y_ISB	ISB part of ME_AWB_Y	byte	[0 to 255]
201	0xC9H	ME_AWB_U_ISB	ISB part of ME_AWB_U	byte	[0 to 255]
202	0xCAH	ME_AWB_V_ISB	ISB part of ME_AWB_V	byte	[0 to 255]
203	0xCBH	ME_AE_#0_ISB	ISB part of ME_AE_no. 0	byte	[0 to 255]
204	0xCCH	ME_AE_#1_ISB	ISB part of ME_AE_no. 1	byte	[0 to 255]
205	0xCDH	ME_AE_#2_ISB	ISB part of ME_AE_no. 2	byte	[0 to 255]
206	0xCEH	ME_AE_#3_ISB	ISB part of ME_AE_no. 3	byte	[0 to 255]
207	0CFH	ME_AE_#4_ISB	ISB part of ME_AE_no. 4	byte	[0 to 255]
208	0xD0H	ME_AWB_Y_LSB	LSB part of ME_AWB_Y	byte	[0 to 255]
209	0xD1H	ME_AWB_U_LSB	LSB part of ME_AWB_U	byte	[0 to 255]
210	0xD2H	ME_AWB_V_LSB	LSB part of ME_AWB_V	byte	[0 to 255]
211	0xD3H	ME_AE_#0_LSB	LSB part of ME_AE_no. 0	byte	[0 to 255]
212	0xD4H	ME_AE_#1_LSB	LSB part of ME_AE_no. 1	byte	[0 to 255]
213	0xD5H	ME_AE_#2_LSB	LSB part of ME_AE_no. 2	byte	[0 to 255]
214	0xD6H	ME_AE_#3_LSB	LSB part of ME_AE_no. 3	byte	[0 to 255]
215	0xD7H	ME_AE_#4_LSB	LSB part of ME_AE_no. 4	byte	[0 to 255]
216	0xD8H	ME_OB_LEVEL	measured optical black level	byte	[0 to 255]
217	0xD9H	READBACK_RGAIN	read back of double-buffered RGAIN	byte	[0 to 255]
218	0xDAH	READBACK_BGAIN	read back of double-buffered BGAIN	byte	[0 to 255]

**Table 9** Register CONTROL 0 (address: 0x00H)

BIT								PARAMETER
7	6	5	4	3	2	1	0	
0								EN_CLK_DPC_RAM: control defect pixel concealment RAM clock disabled
1								enabled
	0							EN_DPC: control defect pixel concealment disabled
	1							enabled
		0						CLK_IF_RESET: control clk1/clk2 interface free running (by default)
		1						reset
			X					toggle phase for line in colour separation
				X				toggle phase for pixel in colour separation
					X			reserved
						0		FORCE_AWBVAL: control AWB window enabled
						1		disabled (integral AWB measurement)
							X	reserved

Digital PC-camera signal processor including microcontroller and USB interface

SAA8116

**Table 10** Register CONTROL 1 (address: 0x01H)

BIT								PARAMETER
7	6	5	4	3	2	1	0	
0	0							DISP_CNTRL: select display signal no display
0	1							D_WC (white clipped pixels)
1	0							D_AWBVAL (pixels according to AWBVAL)
1	1							D_MWG (measurement windows)
		0						RGB_SEP_OFF: RGB reconstructor for raw data mode enabled (normal RGB mode)
		1						disabled (raw data mode)
			X	X				reserved
					0			VCF_GAIN: vertical contour filter gain double
					1			normal
						0	0	WH_CL_MAP: white clip mapping on UV-grid [0 0 1 0 0] spreading filter
						0	1	[0 1 1 1 0] spreading filter
						X	X	[1 1 1 1 1] spreading filter

**Table 11** Register GAMMA\_KNEE (address: 0x17H)

BIT								PARAMETER
7	6	5	4	3	2	1	0	
0								control scaler (5/8 gain) disabled (transparent mode)
1								enabled (normal operation)
	0							control knee disabled
	1							enabled
		X	X	X	X	X	X	gamma balance [0 to 63]/64

**Table 12** Register VC\_CNTRL (address: 0x18H)

BIT								PARAMETER
7	6	5	4	3	2	1	0	
0								control vertical contour horizontal low pass filter disabled
1								enabled
	X	X	X					vertical contour COMB filter gain [0 to 7]/8
				X	X	X	X	vertical contour gain [0 to 15]/16

Digital PC-camera signal processor including microcontroller and USB interface

SAA8116

**Table 13** Register DMWSEL (address: 0x27H)

BIT								PARAMETER
7	6	5	4	3	2	1	0	
X								undefined
	0 1							display measurement window #A for line #3 disabled enabled
		0 1						display measurement window #B for line #2 disabled enabled
			0 1					display measurement window #A for line #2 disabled enabled
				X				undefined
					0 1			display measurement window #A for line #1 disabled enabled
						0 1		display measurement window #B for line #0 disabled enabled
						0 1		display measurement window #A for line #0 disabled enabled

**Table 14** Register DISPLEV (address: 0x28H)

BIT								PARAMETER
7	6	5	4	3	2	1	0	
X	X	X	X	X	X	X	X	set defect pixel display level in defect pixel display mode [4 × [0 to 255]]
X	X	X	X					set Y (luminance) display level to other display modes [16 × [0 to 15]]
				X	X			set U display level to other display modes [64 × [-2 to 1]]
						X	X	set V display level to other display modes [64 × [-2 to 1]]

**Table 15** Register NLINE\_PRESET\_MSB (address: 0x2DH)

BIT								PARAMETER
7	6	5	4	3	2	1	0	
X	X							bits 8 and 9 for PIXCNT_PRESET (by default = 0)
		X						bit 8 for LINECNT_PRESET (by default = 0; note 1)
			X	X	X	X	X	number of lines in a frame [480 + [0 to 31]] (by default = 6)

**Note**

1. Internal LINECNT range is [1 to 511]; no line zero.

Digital PC-camera signal processor including microcontroller and USB interface

SAA8116

**Table 16** Register VHOUT\_MSB\_1 (address: 0x3BH)

BIT								PARAMETER
7	6	5	4	3	2	1	0	
X	X							bits 8 and 9 for VOUT_HNE; note 1
		X	X					bits 8 and 9 for VOUT_HPE; note 1
				X	X			bits 8 and 9 for HOUT_NE
						X	X	bits 8 and 9 for HOUT_PE

**Note**

- Internal LINECNT range is [1 to 511]; no line zero.

**Table 17** Register VHOUT\_MSB\_2 (address: 0x3CH)

BIT								PARAMETER
7	6	5	4	3	2	1	0	
X	X	X						reserved
			X					select HOUT polarity
				X				bit 8 for HOUTWIN_VNE; note 1
					X			bit 8 for HOUTWIN_VPE; note 1
						X		bit 8 for VOUT_VNE; note 1
							X	bit 8 for VOUT_VPE; note 1

**Note**

- Internal LINECNT range is [1 to 511]; no line zero.

**Table 18** Register XSEL (address: 0x3FH)

BIT								PARAMETER
7	6	5	4	3	2	1	0	
X	X	X						reserved
			X	X	X	X	X	mode control for pixel extender

**Table 19** Register TR\_HT\_CONTROL (address: 0x5CH)

BIT								PARAMETER
7	6	5	4	3	2	1	0	
X								undefined
	0 1							HEAD_ENA: control header transfer disabled enabled
		X	X	X				HEAD_LEN: header length
					0 1			TRAIL_ENA: control trailer transfer disabled enabled
						X	X	TRAIL_LEN: trailer length

# Digital PC-camera signal processor including microcontroller and USB interface

SAA8116

**Table 20** Register PPG\_CONTROL\_0 (address: 0x60H)

BIT								PARAMETER
7	6	5	4	3	2	1	0	
X	X	X						undefined
			0 1					SHUTTER_UPDATE_BUFFER: control shutter speed immediate (by default) buffered during vertical blanking
				0 1				select PPG power mode operational (by default) resume
					0 0 0 0 1 1 1	0 0 1 1 0 0 1	0 1 0 1 0 1 X	select PPG timing mode (VGA sensor) frame rate = 30 fps (LLC = 24.0 MHz) frame rate = 24 fps (LLC = 19.2 MHz) frame rate = 20 fps (LLC = 16.0 MHz) frame rate = 15 fps (LLC = 12.0 MHz) frame rate = 10 fps (LLC = 8.0 MHz) frame rate = 5 fps (LLC = 4.0 MHz) undefined

Digital PC-camera signal processor including microcontroller and USB interface

SAA8116

**Table 21** Register PPG\_CONTROL\_1 (address: 0x61H)

BIT								PARAMETER
7	6	5	4	3	2	1	0	
X								reserved
	0	0	0	0				select frequency for compression clock CLK_C off
	0	0	0	1				2.0 MHz
	0	0	1	0				2.4 MHz
	0	0	1	1				4.0 MHz
	0	1	0	0				4.8 MHz
	0	1	0	1				6.0 MHz
	0	1	1	0				8.0 MHz
	0	1	1	1				9.6 MHz
	1	0	0	0				12 MHz (by default)
	1	0	0	1				16 MHz
	1	0	1	0				19.2 MHz
	1	0	1	1				24 MHz
	1	1	X	X				reserved
					0	X		select VGA sensor type reserved
					1	0		VGA type 1 (Sharp LZ24BP; Sony ICX098AK)
					1	1		VGA type 2 (Panasonic MN37771PT)
							X	reserved

# Digital PC-camera signal processor including microcontroller and USB interface

SAA8116

**Table 22** Register PPG\_H\_CTRL (address: 0x62H)

BIT								PARAMETER
7	6	5	4	3	2	1	0	
X								reserved
	0							set RG pulse width nominal value
	1							RG_SHORT: half of nominal value
		0	0	0				FH2_CTRL; note 1 blanked to HIGH; starts LOW
		0	0	1				blanked to LOW; starts HIGH
		0	1	0				blanked to LOW; starts LOW
		0	1	1				blanked to HIGH; starts HIGH
		1	X	0				no horizontal blanking; pulse inverted
		1	X	1				no horizontal blanking
					0	0	0	FH1_CTRL; note 1 blanked to LOW; starts HIGH
					0	0	1	blanked to HIGH; starts LOW
					0	1	0	blanked to HIGH; starts HIGH
					0	1	1	blanked to LOW; starts LOW
					1	X	0	no horizontal blanking; pulse inverted
					1	X	1	no horizontal blanking

**Note**

1. If bits [5 to 3] equal bits [2 to 0] then FH2 is the inverse of FH1.

Digital PC-camera signal processor including microcontroller and USB interface

SAA8116

**Table 23** Register PPG\_V\_INV (address: 0x63H)

BIT								PARAMETER
7	6	5	4	3	2	1	0	
	0 1							FV4_INV negative pulses positive pulses
	0 1							FV3_INV negative pulses positive pulses
		0 1						FV2_INV positive pulses negative pulses
			0 1					FV1_INV positive pulses negative pulses
				0 1				ROG1_INV; note 1 negative pulses positive pulses
					0 1			ROG2_INV; note 1 negative pulses positive pulses
						X	X	reserved

**Note**

1. ROG1\_INV and ROG2\_INV are related to ROG\_SEL (see Table 41; PIN\_CONFIG\_0[0]). If ROG\_SEL = 0, then ROG2\_INV is activated (with Sony or Sharp CCD applications) and ROG1\_INV is disabled. If ROG\_SEL = 1, then ROG1\_INV is activated (with Panasonic CCD applications) and ROG2\_INV is disabled.



Digital PC-camera signal processor including microcontroller and USB interface

SAA8116

**Table 24** Register PPG\_H\_INV (address: 0x64H)

BIT								PARAMETER
7	6	5	4	3	2	1	0	
0								CLK2_INV nominal pulses inverted pulses
1								
	0							CLK1_INV nominal pulses inverted pulses
	1							
		0						FS_INV negative pulses positive pulses
		1						
			0					FCDS_INV negative pulses positive pulses
			1					
				0				RG_INV negative pulses positive pulses
				1				
					X			reserved
						0		FH2_INV positive pulses negative pulses
						1		
							0	FH1_INV positive pulses
							1	negative pulses

Digital PC-camera signal processor including microcontroller and USB interface

SAA8116

**Table 25** Register PPG\_MISC\_INV (address: 0x65H)

BIT								PARAMETER
7	6	5	4	3	2	1	0	
X								reserved
	0 1							SELECT_FV3 FV3 equals FV2 FV3 equals FV4 (with VGA type 1 sensors)
		X						reserved
			0 1					CRST_INV negative pulses positive pulses
				0 1				BCP_INV positive pulses negative pulses
								DCP_INV
					0 1			positive pulses negative pulses
						0 1		H_INV positive pulses negative pulses
							0 1	V_INV positive pulses negative pulses

**Table 26** Register PPG\_SHUTTERSPEED\_V\_LSB (address: 0x66H)

BIT								PARAMETER
7	6	5	4	3	2	1	0	
X	X	X	X	X	X	X	X	8 LSBs of line number (9 bits) on which shutter speed is updated

**Table 27** Register PPG\_SHUTTERSPEED\_H\_LSB (address: 0x67H)

BIT								PARAMETER
7	6	5	4	3	2	1	0	
X	X	X	X	X	X	X	X	8 LSBs of pixel number (10 bits) on which shutter speed is updated

Digital PC-camera signal processor including microcontroller and USB interface

SAA8116

**Table 28** Register PPG\_SHUTTERSPEED\_MSB (address: 0x68H)

BIT								PARAMETER
7	6	5	4	3	2	1	0	
X	X	X	X					reserved
				0				SENSOR_TYPE Sharp
				1				Sony
					X	X		2 MSBs of pixel number (10 bits)
							X	MSB of line number (9 bits)

**Table 29** Register PPG\_BCP\_START\_LSB (address: 0x69H)

BIT								PARAMETER
7	6	5	4	3	2	1	0	
X	X	X	X	X	X	X	X	8 LSBs of pixel number (10 bits) where BCP starts

**Table 30** Register PPG\_BCP\_STOP\_LSB (address: 0x6AH)

BIT								PARAMETER
7	6	5	4	3	2	1	0	
X	X	X	X	X	X	X	X	8 LSBs of pixel number (10 bits) where BCP stops

**Table 31** Register PPG\_DCP\_START\_LSB (address: 0x6BH)

BIT								PARAMETER
7	6	5	4	3	2	1	0	
X	X	X	X	X	X	X	X	8 LSBs of pixel number (10 bits) where DCP starts

**Table 32** Register PPG\_DCP\_STOP\_LSB (address: 0x6CH)

BIT								PARAMETER
7	6	5	4	3	2	1	0	
X	X	X	X	X	X	X	X	8 LSBs of pixel number (10 bits) where DCP stops

**Table 33** Register PPG\_BCP\_DCP\_MSB (address: 0x6DH)

BIT								PARAMETER
7	6	5	4	3	2	1	0	
X	X							2 MSBs of PPG_DCP_STOP
		X	X					2 MSBs of PPG_DCP_START
				X	X			2 MSBs of PPG_BCP_STOP
						X	X	2 MSBs of PPG_BCP_START

Digital PC-camera signal processor including microcontroller and USB interface

SAA8116

**Table 34** Register PPG\_ROG1\_START\_LSB (address: 0x6EH)

BIT								PARAMETER
7	6	5	4	3	2	1	0	
X	X	X	X	X	X	X	X	8 LSBs of pixel number (10 bits) where ROG1 starts

**Table 35** Register PPG\_ROG1\_STOP\_LSB (address: 0x6FH)

BIT								PARAMETER
7	6	5	4	3	2	1	0	
X	X	X	X	X	X	X	X	8 LSBs of pixel number (10 bits) where ROG1 stops

**Table 36** Register PPG\_ROG2\_START\_LSB (address: 0x70H)

BIT								PARAMETER
7	6	5	4	3	2	1	0	
X	X	X	X	X	X	X	X	8 LSBs of pixel number (10 bits) where ROG2 starts

**Table 37** Register PPG\_ROG2\_STOP\_LSB (address: 0x71H)

BIT								PARAMETER
7	6	5	4	3	2	1	0	
X	X	X	X	X	X	X	X	8 LSBs of pixel number (10 bits) where ROG2 stops

**Table 38** Register PPG\_ROG1\_2\_MSB (address: 0x72H)

BIT								PARAMETER
7	6	5	4	3	2	1	0	
X	X							2 MSBs of PPG_ROG2_STOP
		X	X					2 MSBs of PPG_ROG2_START
				X	X			2 MSBs of PPG_ROG1_STOP
						X	X	2 MSBs of PPG_ROG1_START

Digital PC-camera signal processor including microcontroller and USB interface

SAA8116

**Table 39** Register VFC\_CONTROL\_0 (address: 0x73H)

BIT								PARAMETER
7	6	5	4	3	2	1	0	
X								RESET_VP_C: reset compression module of video processing
	X							RESET_VP_VF: reset video formatter of video processing
		0	0					SCALE_DATA: limits the number of bits of the video formatter output 8 bits
		0	1					7 bits
		1	0					6 bits
		1	1					undefined
				0	0			PREFILTER_SEL_UV: select horizontal UV downscaling prefilter no prefilter (bypass)
				0	1			prefilter for downscaling to SIF with 3 taps
				1	0			prefilter for downscaling to QSIF with 5 taps
				1	1			undefined
						0	0	PREFILTER_SEL_Y: select horizontal Y downscaling prefilter no prefilter (bypass)
						0	1	prefilter for downscaling to SIF with 3 taps
						1	0	prefilter for downscaling to QSIF with 5 taps
						1	1	undefined

Digital PC-camera signal processor including microcontroller and USB interface

SAA8116

**Table 40** Register VFC\_CONTROL\_1 (address: 0x74H)

BIT								PARAMETER
7	6	5	4	3	2	1	0	
0	0	0						Q_TABLE_SELECT: select quantization table for the compression engine compression ratio = 2 (raw mode table) (by default)
0	0	1						compression ratio = 3
0	1	0						compression ratio = 4
0	1	1						compression ratio = 5
1	0	0						compression ratio = 6; with one bit shift
1	0	1						compression ratio = 7; with one bit shift
1	1	0						compression ratio = 7.5; with one bit shift
1	1	1						compression ratio = 8; with one bit shift
			0	0				LDC: length of DC coefficient used in the compression engine 6 bits
			0	1				7 bits
			1	0				8 bits
			1	1				undefined
					0	0	0	VOF: select video output format SIF compressed (by default)
					0	0	1	SIF uncompressed
					0	1	0	QSIF compressed
					0	1	1	QSIF uncompressed
					1	0	0	VGA compressed
					1	0	1	VGA raw compressed
					1	1	0	undefined
					1	1	1	undefined

# Digital PC-camera signal processor including microcontroller and USB interface

SAA8116

**Table 41** Register PIN\_CONFIG\_0 (address: 0x7EH)

BIT								PARAMETER
7	6	5	4	3	2	1	0	
X	X	X	X	X	X			reserved
							0	P4_SEL: when enabled; pins are configured as general purpose outputs; otherwise they are connected to FV1; FV2 and FV3 disabled
							1	enabled (by default)
							0	ROG_SEL: select ROG signal according to CCD type PPG output ROG1 (Sony and Sharp CCD application) (by default)
							1	PPG output ROG2 (Panasonic CCD application)

**Table 42** Register PIN\_CONFIG\_1 (address: 0x7FH)

BIT								PARAMETER
7	6	5	4	3	2	1	0	
							0	PR_DISABLE: control remote wake-up 2 enabled
							1	disabled (by default)
		0						SR_DISABLE: control remote wake-up 1 enabled
		1						disabled (by default)
			0					SPIF_SEL: select interface between sensor and preprocessor use serial interface (by default)
			1					use port P4[2 to 0]
				0				ASCLK_SEL: select ASCLK clock ASCLK = single pixel clock (by default)
				1				ASCLK = double pixel clock
					0	0		VSP_VH_SEL: select connection type of VSP pins V and H V = external V pulse (input); H = PPG_HD (output); VSP_VIN = PPG_VD
						0	1	V = external V pulse (input); H = VSP_HOUT (output); VSP_VIN = external V pulse
						1	0	V = PPG_VD (output); H = PPG_HD (output); VSP_VIN = PPG_VD
						1	1	V = VSP_VOUT (output); H = VSP_HOUT (output); VSP_VIN = 0
							0	PCLK_INV: control pixel clock normal (by default)
							1	inverted
							0	VSP_CLK_SEL: select VSP clock VSP_CLK = CLK1 from PPG (by default)
							1	VSP_CLK = PCLK

# Digital PC-camera signal processor including microcontroller and USB interface

SAA8116

## Audio and power-management registers

A first MOVX@DPTR instruction enables to select the module (via DPH) and send the command. A second one communicates the data (read or write).

**Table 43** Register list

ADDRESS	NAME	FUNCTION	FORMAT
<b>Write registers</b>			
0	0x00H	AUDIO_CLOCKS	audio clocks control
1	0x01H	RSTGEN	reset generator control
2	0x02H	ANALOG_POWER	analog power control
3	0x03H	POWERMGT_N1	timer N1 (by default = 24)
4	0x04H	POWERMGT_N2	timer N2 (by default = 57)
5	0x05H	AUDIO	audio properties control
<b>Read register</b>			
6	0x06H	POWERMGT_STATUS	power management status bits (read register)

**Table 44** Register AUDIO\_CLOCKS (address: 0x00H)

BIT								PARAMETER
7	6	5	4	3	2	1	0	
0	0							SET_DIVIDE: set clock dividers for ADC
0	1							divide by 1 (by default)
1	0							divide by 2
1	1							divide by 4
		X						divide by 8
			X					reserved
			0					DIS_CLK_AD: disable 48 MHz clock (ADC)
			1					enabled (by default)
				X				disabled
					X			reserved
						0	0	FCODE: set the PLL frequency
						0	1	256 × 44.1 KHz (by default)
						1	0	256 × 32 KHz
						1	1	256 × 48 KHz
								256 × 44.1 KHz
							X	reserved



Digital PC-camera signal processor including microcontroller and USB interface

SAA8116

**Table 45** Register RSTGEN (address: 0x01H)

BIT								PARAMETER
7	6	5	4	3	2	1	0	
0								UPC_RST_AUD26: reset generator for USB (aud26) module controlled by the power management (by default) forced
1	X							reserved
		0						UPC_RST_ADIF: reset generator for audio module controlled by the power management (by default) forced
		1						forced
			X	X	X	X	X	reserved

**Table 46** Register ANALOG\_POWER (address: 0x02H)

BIT								PARAMETER
7	6	5	4	3	2	1	0	
0								UPC_OSC_OFF: set power safe mode disabled (by default) enabled
1	X							reserved
		0						UPC_PLL_OFF: control PLL power enabled (by default) disabled
		1						disabled
			X					reserved
				0				UPC_ADL_OFF: control ADC power (left channel) enabled (by default) disabled
				1				disabled
					X	X	X	reserved

Digital PC-camera signal processor including microcontroller and USB interface

SAA8116

**Table 47** Register AUDIO (address: 0x05H)

BIT								PARAMETER
7	6	5	4	3	2	1	0	
0								HP_EN: set high pass filter disabled
1								enabled (by default)
	X							reserved
		0						MUTE_ON: set audio mute mute is off (by default)
		1						mute is on
			X					reserved
				0	0	0	0	gain control; 0 to 30 dB in steps of 2 dB 0 dB (by default)
				0	0	0	1	2 dB
								....
				1	1	1	0	28 dB
				1	1	1	1	30 dB

**Table 48** Register POWERMGT\_STATUS (address: 0x06H)

BIT								PARAMETER
7	6	5	4	3	2	1	0	
X								STATUS_POWERUPBIT: set to 1 after a Power-on reset (by default = 1)
	X							STATUS_BUSRESETBIT: set to 1 after a bus reset (by default = 0)
		X						STATUS_RESUMEBIT: set to 1 after a resume (by default = 0)
			X					STATUS_RW_BIT: set to 1 after remote wake-up is triggered (by default = 0)
				X	X	X	X	reserved

# Digital PC-camera signal processor including microcontroller and USB interface

SAA8116

## USB registers

A first MOVX@DPTR instruction enables module selection (via DPH) and command transmission. A second MOVX communicates the data (read or write).

**Table 49** Register list

ADDRESS	NAME	FUNCTION	FORMAT
<b>Write registers</b>			
208	0xD0H	SET_ADDRESS	set address
216	0xD8H	SET_EP_ENABLE	set EP enable
243	0xF3H	GETSET_MODE	set mode
<b>Read registers</b>			
0	0x00H	SELECT_EP0_out	select EP 0 out
1	0x01H	SELECT_EP0_in	select EP 0 in
2	0x02H	SELECT_EP1_OUT	select EP 1 out
3	0x03H	SELECT_EP1_IN	select EP 1 in
4	0x04H	SELECT_EP2	select EP 2
5	0x05H	SELECT_EP3	select EP 3
242	0xF2H	SET_BUFFER_FE	clear selected EP buffer
244	0xF4H	GET_INTERRUPT	read interrupt register
245	0xF5H	GET_FRAMENUMBER	read current frame number
250	0xFAH	VALIDATE_BUFFER	validate selected EP
253	0xFDH	GET_CHIPID	read chip identifier
<b>Read/write registers</b>			
64	0x40H	SELECT_EP0_OUT_STATUS	select EP; clear interrupt and get information of EP 0 (out)
65	0x41H	SELECT_EP0_IN_STATUS	select EP; clear interrupt and get information of EP 0 (in)
66	0x42H	SELECT_EP1_OUT_STATUS	select EP; clear interrupt and get information of EP 1 (out)
67	0x43H	SELECT_EP1_IN_STATUS	select EP; clear interrupt and get information of EP 1 (in)
68	0x44H	SELECT_EP2_STATUS	select EP; clear interrupt and get information of EP 2
69	0x45H	SELECT_EP3_STATUS	select EP; clear interrupt and get information of EP 3
70	0x46H	SELECT_EP4_STATUS	clear interrupt and get information of EP 4
71	0x47H	SELECT_EP5_STATUS	get information of EP 5
240	0xF0H	RW_DATA	read selected EP buffer
254	0xFEH	GETSET_DEVICE_STATUS	set device status

## Notes

1. The GET\_FRAMENUMBER command returns the frame number of the last received Start Of Frame (SOF). The frame number is 11 bits wide; therefore two consecutive reads are needed to get the complete value. The first byte provides the LSBs; the second byte (bits 0 to 2) provides the 3 MSBs. Note: it is possible to read the first byte only.
2. The GET\_CHIPID command is followed by two reads since the chip identification is 16 bits wide (see Tables 55 and 56).
3. The RW\_DATA command can be followed by up to 'n + 2' bytes read or write (n is the number of data bytes in the selected EP buffer). With read, it returns the contents of the selected EP data buffer. With write, it loads the data buffer of the selected EP.

# Digital PC-camera signal processor including microcontroller and USB interface

SAA8116

**Table 50** Register SET\_ADDRESS (address: 0xD0H)  
Detailed description of the write (1 byte) following command 0xD0H

BIT								PARAMETER
7	6	5	4	3	2	1	0	
X								ENABLE_ADD: enable the function (by default = 0)
	X	X	X	X	X	X	X	DEVICE_address: set the USB assigned address (by default = 0)

**Table 51** Register SET\_EP\_ENABLE (address: 0xD8H)  
Detailed description of the write (1 byte) following command 0xD8H

BIT								PARAMETER
7	6	5	4	3	2	1	0	
X	X	X	X	X	X	X		reserved
							0	ENABLE_EP: enable end-point Non-control end-points are disabled (by default)
							10	Non-control end-points are enabled

**Table 52** Register GETSET\_MODE (address: 0xF3H)  
Detailed description of the write (one byte) following command 0xF3H; notes 1, 2 and 3

BIT								PARAMETER
7	6	5	4	3	2	1	0	
X	X	X	X	X				reserved
					0			FIFO_ACTIVE: set the video FIFO status FIFO is inactive; only zero-length packet are sent upstream
					1			functional mode (by default)
						0		ALWAYS_PLLCLOCK: control internal clock signals clocks and PLL are stopped whenever not needed (e.g. suspend mode)
						1		clocks and PLL are always running even in suspend mode (by default)
							0	INTERRUPT_ONNAK: control transaction reporting only successful transactions are reported
							1	NAK is reported and generates an interrupt (by default)

## Notes

1. GETSET\_MODE command can write from 1 to 4 consecutive bytes. The detailed description above concerns byte 0.
2. GETSET\_MODE bytes 1 and 2 are used to set the size of the isochronous video packets. Byte 1 corresponds to the LSB to define the packet size. Bits 0 and 1 of byte 2 set the 2 MSBs. By default, the two bytes are forced to 0.
3. GETSET\_MODE byte 3 sets the FIFO offset.

Digital PC-camera signal processor including microcontroller and USB interface

SAA8116

**Table 53** Register SELECT\_EP0\_OUT (address: 0x00H)  
Detailed description of the optional read (1 byte) following command 0x00H; note 1

BIT								PARAMETER
7	6	5	4	3	2	1	0	
X	X	X						reserved
			0 1					SENT_NAK: a NAK is not sent (by default) a NAK is sent by the device
				0 1				PACKET_OVERWRITTEN: not overwritten (by default) the previously received packet was overwritten by a setup packet
					0 1			SETUP_PACKET: give the status of the last received packet not a setup packet (by default) last received packet for the selected EP was a setup packet
						0 1		STALL_PACKET: give the status of the selected EP not stall (by default) stall
							0 1	BUFFER_STATUS: give the EP buffer status; note 2; this bit is cleared by executing the SET_BUFFER_FE command buffer not full (by default) buffer of the selected EP is full

**Notes**

1. The SELECT\_EPX\_XX command selects the corresponding EP buffer. It can be followed optionally by a data read, which provides the EP status to the microcontroller (see the detailed description above). Whatever the EP (from 0 to 3) or its direction, the sequence is the same. Note that isochronous EP cannot be selected in this way.
2. BUFFER\_STATUS: in case of an IN endpoint; this bit is set by the VALIDATE\_BUFFER command.

**Table 54** Register GET\_INTERRUPT (address: 0xF4H)  
Detailed description of the read (1 byte) following command 0xF4H

BIT								PARAMETER
7	6	5	4	3	2	1	0	
X								DEVICE_EVENT: an event occurred in the device
	X							PHYSICAL_EP6: interrupt signal comes from (logic) EP4
		X						PHYSICAL_EP5: interrupt signal comes from (logic) EP3
			X					PHYSICAL_EP4: interrupt signal comes from (logic) EP2
				X				PHYSICAL_EP3: interrupt signal comes from (logic) EP1 in
					X			PHYSICAL_EP2: interrupt signal comes from (logic) EP1 out
						X		PHYSICAL_EP1: interrupt signal comes from (logic) EP0 in
							X	PHYSICAL_EP0: interrupt signal comes from (logic) EP0 out

# Digital PC-camera signal processor including microcontroller and USB interface

SAA8116

**Table 55** Register GET\_CHIP\_ID BYTE 0 (address: 0xFDH)  
Detailed description of the read (byte 0) following command 0xFDH

BIT								PARAMETER
7	6	5	4	3	2	1	0	
X	X	X	X	X				PRODUCT_ID: 5 LSBs of the product identification (by default = 10011)
					X	X	X	REVISION_NB: revision number (by default = 001)

**Table 56** Register GET\_CHIP\_ID BYTE 1 (address: 0xFDH)  
Detailed description of the read (byte 1) following command 0xFDH

BIT								PARAMETER
7	6	5	4	3	2	1	0	
X	X	X	X	X	X			CUSTOMER_ID: customer identification (by default = 110011)
						X	X	PRODUCT_ID: 2 MSBs of the product identification (by default = 00)

# Digital PC-camera signal processor including microcontroller and USB interface

SAA8116

## LIMITING VALUES

In accordance with the Absolute Maximum Rating System (IEC 60134); note 1.

SYMBOL	PARAMETER	MIN.	MAX.	UNIT
$V_{DD}$	supply voltage	-0.5	+4.0	V
$V_n$	voltage on pins GND and AGND	-0.5	+4.0	V
	all other pins	-0.5	$V_{DD} + 0.5$	V
$T_{stg}$	storage temperature	-55	+150	°C
$T_{amb}$	ambient temperature	0	70	°C
$T_j$	junction temperature	-40	+125	°C

### Note

1. Stress beyond these levels may cause permanent damage to the device.

## THERMAL CHARACTERISTICS

SYMBOL	PARAMETER	CONDITIONS	VALUE	UNIT
$R_{th(j-a)}$	thermal resistance from junction to ambient	in free air	53	K/W

# Digital PC-camera signal processor including microcontroller and USB interface

SAA8116

## CHARACTERISTICS

$V_{DD} = V_{DDD} = V_{DDA} = 3.3 \text{ V} \pm 10\%$ ;  $T_{\text{amb}} = 0 \text{ to } 70 \text{ }^\circ\text{C}$ ; unless otherwise specified; note 1.

SYMBOL	PARAMETER	CONDITIONS	MIN.	TYP.	MAX.	UNIT
<b>Supplies</b>						
$V_{DD}$	supply voltage		3.0	3.3	3.6	V
$V_{DDD}$	supply voltage for digital core		3.0	3.3	3.6	V
$V_{DDA}$	analog supply voltage		3.0	3.3	3.6	V
$I_{DDD(\text{tot})}$	total digital supply current	$V_{DD} = V_{DDD} = 3.3 \text{ V}$ ; $T_{\text{amb}} = 25 \text{ }^\circ\text{C}$	–	65 <sup>(2)</sup>	85 <sup>(3)</sup>	mA
$I_{DDA(\text{tot})}$	total analog supply current	$V_{DDA} = 3.3 \text{ V}$ ; $T_{\text{amb}} = 25 \text{ }^\circ\text{C}$	–	16	–	mA
$I_{DDQ(\text{susp})}$	total suspend current	$V_{DDA} = 3.3 \text{ V}$ ; $T_{\text{amb}} = 25 \text{ }^\circ\text{C}$	–	–	400 <sup>(3)</sup>	$\mu\text{A}$
<b>Digital data and control inputs</b>						
$V_{IL}$	LOW-level input voltage		–	–	0.8	V
$V_{IH}$	HIGH-level input voltage		2	–	–	V
<b>Digital data and control outputs</b>						
$V_{OL}$	LOW-level output voltage		0	–	$0.1V_{DD}$	V
$V_{OH}$	HIGH-level output voltage		$0.9V_{DD}$	–	$V_{DD}$	V
<b>LDO supply filter</b>						
$V_{\text{ref}}$	reference voltage	at $0.5V_{DDA}$	–	1.50	–	V
$V_O$	output voltage on pin LDOOUT	$V_{DDA} = 3.0 \text{ V}$	–	3.0	–	V
$I_O$	output current on pin LDOOUT		–	5	10	mA
<b>Microphone supply</b>						
$I_{DDA}$	supply current		–	0.85	1.2	mA
$V_{\text{ref}}$	reference voltage	at $0.5V_{DDA}$	–	1.50	–	V
$V_O$	output voltage on pin MICSUPPLY	$V_{DDA} = 3.0 \text{ V}$	–	2.7	–	V
$I_O$	output current on pin MICSUPPLY		–	–	2.0	mA
<b>Audio low noise amplifier</b>						
TRANSFER FUNCTION						
$R_i$	input resistance		3.5	5.0	–	$\text{k}\Omega$
$I_{DDA}$	supply current		–	0.85	1.2	mA
A	amplification		29	30	31	dB
THD	total harmonic distortion	note 4	–	–77	–70	dB
$V_{o(\text{rms})}$	output voltage (RMS value)		–	–	800	mV
$V_{OO}$	output offset voltage		–	0.0	1.0	mV
BIASING						
$I_{\text{ref}}$	reference current		–	10	–	$\mu\text{A}$



# Digital PC-camera signal processor including microcontroller and USB interface

SAA8116

SYMBOL	PARAMETER	CONDITIONS	MIN.	TYP.	MAX.	UNIT
<b>Programmable audio gain amplifier</b>						
TRANSFER FUNCTION						
$R_i$	input resistance		7.0	10.5	25	$k\Omega$
$I_{DDA}$	supply current		–	0.45	0.6	mA
$V_{OO}$	output offset voltage	A = 0 dB	–	1.0	2.0	mV
		A = 30 dB	–	14	30	mV
A	amplification		0.2	–	32	dB
THD	total harmonic distortion	A = 0 dB; note 4	–	–89	–85	dB
		A = 30 dB; note 4	–	–66	–62	dB
BIASING						
$I_{ref}$	reference current		–	10	–	$\mu A$
<b>Audio phase-locked loop</b>						
$f_{i(clk)}$	clock input frequency		–	48	–	MHz
$f_{o(clk)}$	clock output frequency	note 5	–	8.1920	–	MHz
			–	11.290	–	MHz
			–	12.288	–	MHz
B	bandwidth		–	2.3	–	kHz
$\zeta$	damping coefficient		–	0.98	–	
<b>Audio ADC (<math>\Sigma\Delta</math> converter)</b>						
INPUTS						
$f_i$	input signal frequency		1	–	20	kHz
$V_{i(rms)}$	input voltage (RMS value)		–	800	–	mV
TRANSFER FUNCTION						
N	order of the $\Sigma\Delta$		–	3	–	
$N_{bit}$	number of output bits		–	1	–	
$N_{bit(eq)}$	equivalent output resolution (bit)		–	16	–	
$DR_i$	dynamic range at input	note 6	–	96.6	–	dB
$f_{clk}$	clock frequency		–	–	5.6448	MHz
$\delta$	clock frequency duty factor		–	50	–	%
THD	total harmonic distortion		–	–73	–60	dB
<b>ATX transceiver full speed mode: pins ATXDP and ATXDN</b>						
DRIVER CHARACTERISTICS						
$t_{t(rise)}$	rise transition time	$C_L = 50$ pF	4	–	20	ns
$t_{t(fall)}$	fall transition time	$C_L = 50$ pF	4	–	20	ns
$t_{t(match)}$	transition time matching	note 7	90	–	110	%
$V_{cr}$	output signal crossover voltage		1.3	–	2.0	V
$Z_o$	driver output impedance	steady state drive	30	–	42	$\Omega$

# Digital PC-camera signal processor including microcontroller and USB interface

SAA8116

SYMBOL	PARAMETER	CONDITIONS	MIN.	TYP.	MAX.	UNIT
RECEIVER CHARACTERISTICS						
$f_{i(D)}$	data input frequency rate		–	12.00	–	Mbits/s
$t_{frame}$	frame interval		–	1.000	–	ms

**Notes**

1. Including the current through the external 1.5 k $\Omega$  resistor connected to ATXDP.
2. Typical: VGA at 15 fps.
3. Maximum: SIF at 30 fps.
4. The distortion is measured at HIGH level; 1 kHz and  $V_o = 800$  mV (RMS).
5. Frequencies depend on PLL settings; see also Table 6.
6. Defined here as:  $20 \times \log \frac{\text{input voltage}}{\text{equivalent input noise voltage}}$
7. Transition time matching:  $t_{t(\text{match})} = \frac{t_{t(\text{rise})}}{t_{t(\text{fall})}} \times 100\%$

# Digital PC-camera signal processor including microcontroller and USB interface

SAA8116

**TIMING**
 $V_{DD} = V_{DDA} = 3.3 \text{ V} \pm 10\%$ ;  $T_{\text{amb}} = 0 \text{ to } 70 \text{ }^{\circ}\text{C}$ .

SYMBOL	PARAMETER	CONDITIONS	MIN.	TYP.	MAX.	UNIT
<b>Data input related to ASCLK for CCD sensors; (see Fig.10)</b>						
PINS PXL0 TO PXL7						
$t_{\text{su}(i)(D)}$	data input set-up time		1.5	–	–	ns
$t_{\text{h}(i)(D)}$	data input hold time		1.5	–	–	ns
<b>PPG high-speed pulses for SONY ICX098AK VGA CCD sensor at 30 fps; (see Fig.11)</b>						
$t_{d1}$	delay between falling edge FH2 and rising edge FH1		–4	–2	0	ns
$t_{d2}$	delay between rising edge FH2 and falling edge FH1		0	1.5	3	ns
$t_{d3}$	delay between falling edge FH1 and rising edge FCDS		10.5	12	13.5	ns
$t_{d4}$	delay between rising edge FH1 and rising edge FS		10	12.5	15	ns
$t_{d5}$	delay between rising edge FH1 and falling edge RG		0	2	4	ns
$t_{d6}$	delay between falling edge ASCLK and rising edge FH1		–3	–1.5	0	ns
$t_{d7}$	delay between rising edge ASCLK and falling edge FH1		2	6	10	ns
$t_{\text{WH}(FH1)}$	FH1 pulse width HIGH		38	39.5	–	ns
$t_{\text{WL}(FH2)}$	FH2 pulse width LOW		41	42.5	–	ns
$t_{\text{WL}(FCDS)}$	FCDS pulse width LOW		6	7	–	ns
$t_{\text{WL}(FS)}$	FS pulse width LOW		18	20.5	–	ns
$t_{\text{WL}(RG)}$	RG pulse width LOW		20	21.5	–	ns
$t_{\text{WL}(ASCLK)}$	ASCLK pulse width LOW		40	43.5	–	ns
$t_r$	rise time	note 1				
	pulse FH1		–	4	–	ns
	pulse FH2		–	4	–	ns
	pulse RG		–	4	–	ns
	pulse FCDS		–	4	–	ns
	pulse FS		–	4	–	ns
$t_f$	fall time	note 1				
	pulse FH1		–	4	–	ns
	pulse FH2		–	4	–	ns
	pulse RG		–	4	–	ns
	pulse FCDS		–	4	–	ns
	pulse FS		–	4	–	ns

**Note**

1.  $C_L = 11 \text{ pF}$ ;  $T_{\text{amb}} = 25 \text{ }^{\circ}\text{C}$ .

Digital PC-camera signal processor including microcontroller and USB interface

SAA8116

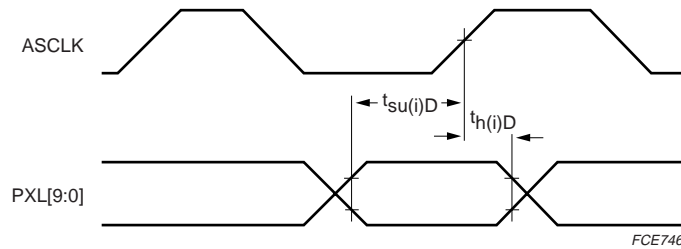

Fig.10 Data input timing.

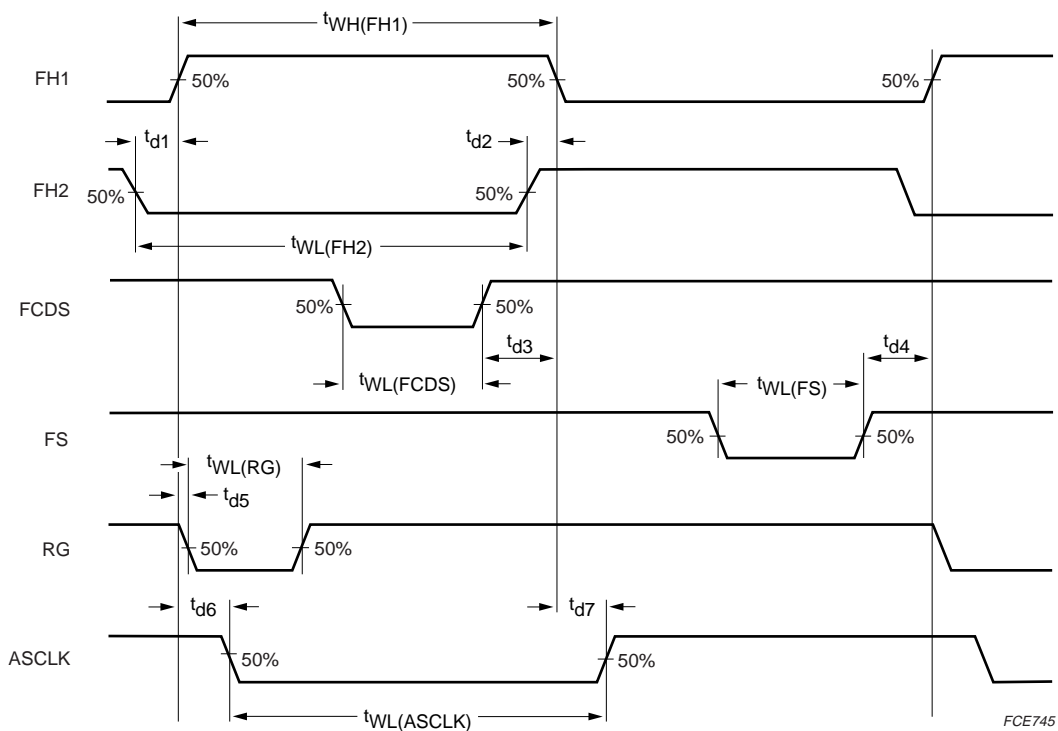

Fig.11 PPG high-speed pulses for Sony ICX098AK VGA CCD sensor.

# Digital PC-camera signal processor including microcontroller and USB interface

SAA8116

## APPLICATION INFORMATION

In the event that the internal ROM is used (pin EA set HIGH), it is strongly recommended to connect pins P0.0 to P0.7 to ground to avoid any leakage that would increase the current in suspend mode.

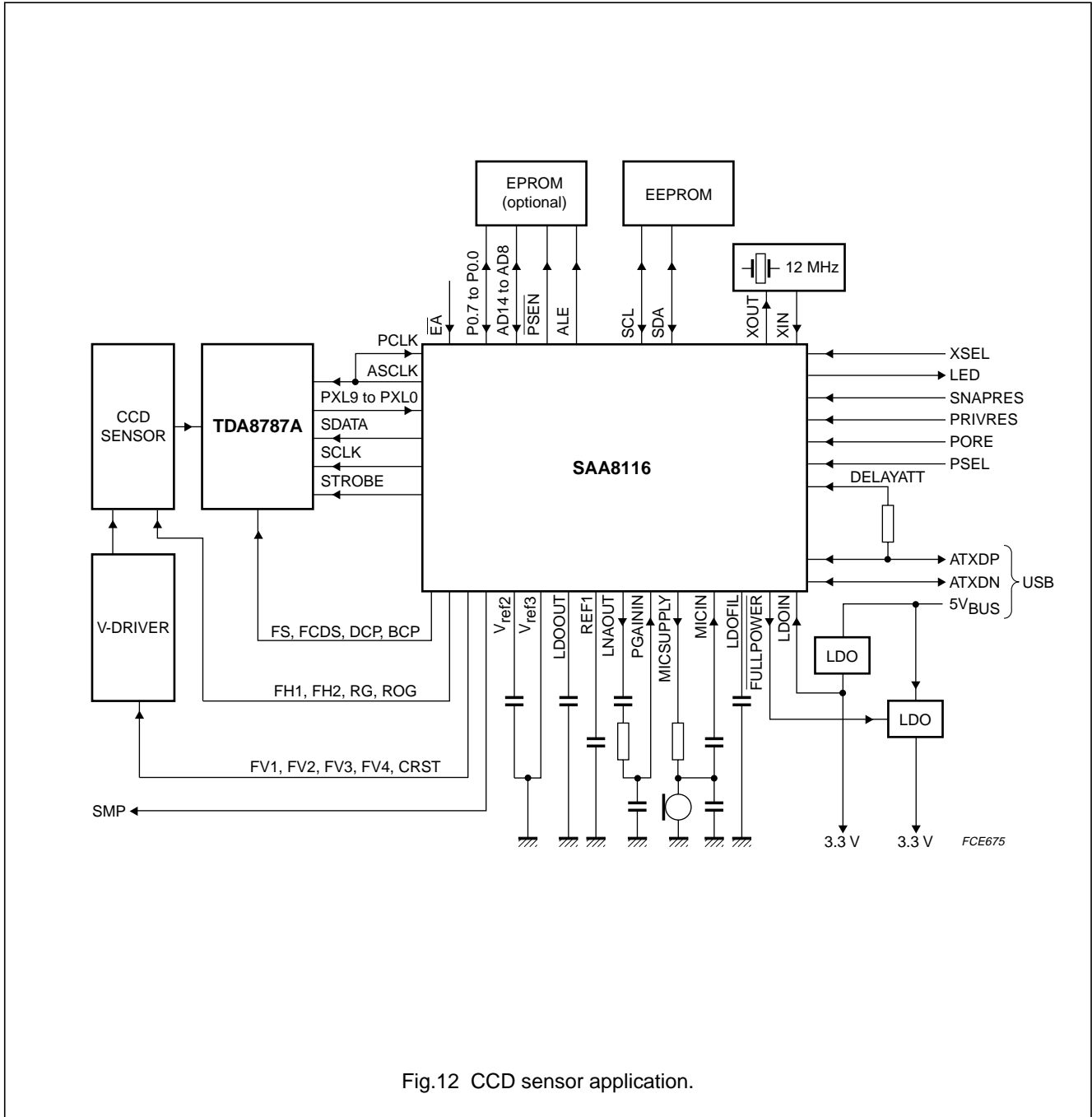

# Digital PC-camera signal processor including microcontroller and USB interface

SAA8116

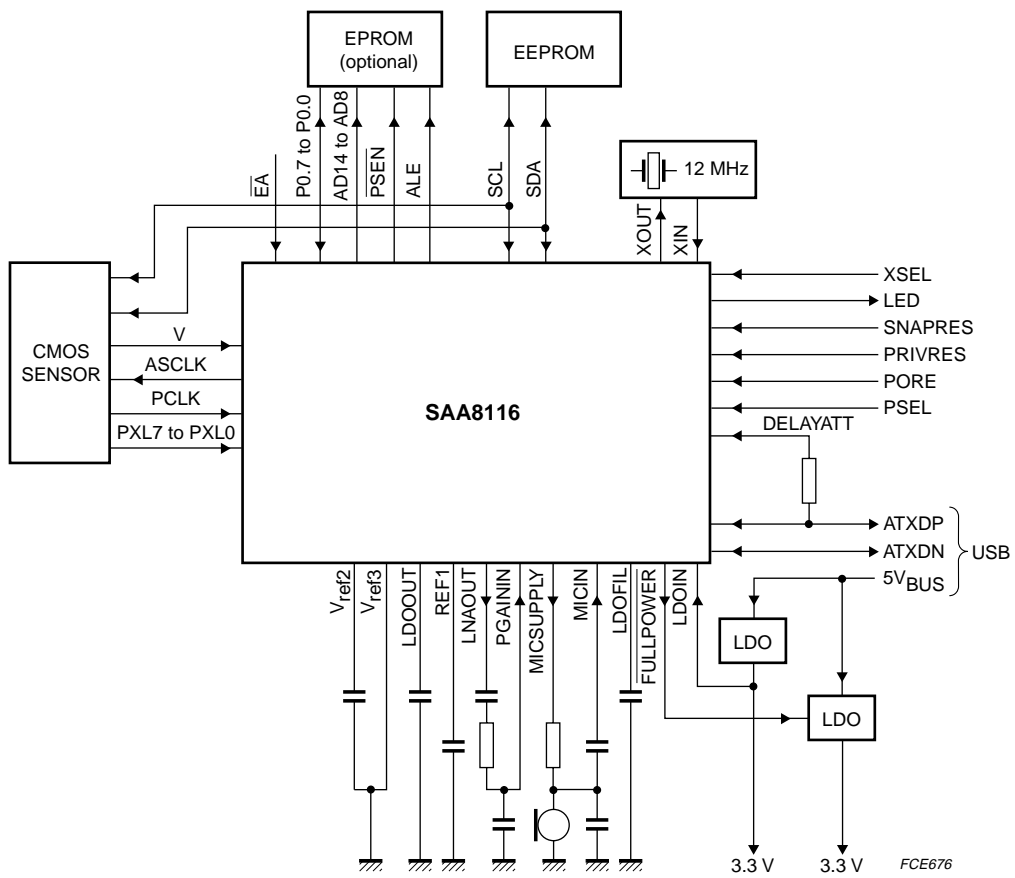

Fig.13 CMOS sensor application.

# Digital PC-camera signal processor including microcontroller and USB interface

SAA8116

## PACKAGE OUTLINES

LQFP100: plastic low profile quad flat package; 100 leads; body 14 x 14 x 1.4 mm

SOT407-1

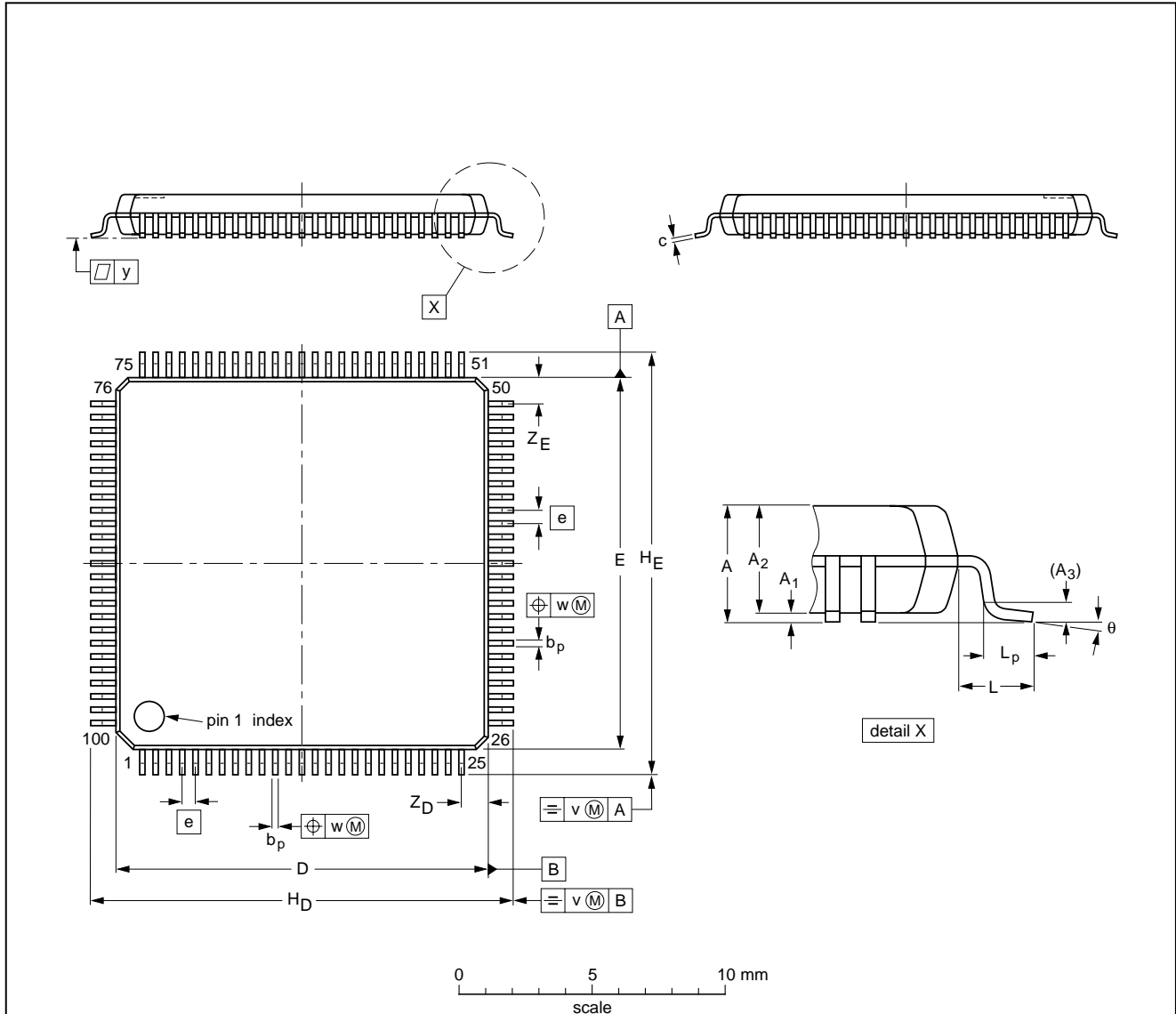

**DIMENSIONS (mm are the original dimensions)**

UNIT	A max.	A <sub>1</sub>	A <sub>2</sub>	A <sub>3</sub>	b <sub>p</sub>	c	D <sup>(1)</sup>	E <sup>(1)</sup>	e	H <sub>D</sub>	H <sub>E</sub>	L	L <sub>p</sub>	v	w	y	Z <sub>D</sub> <sup>(1)</sup>	Z <sub>E</sub> <sup>(1)</sup>	θ
mm	1.6	0.15 0.05	1.45 1.35	0.25	0.27 0.17	0.20 0.09	14.1 13.9	14.1 13.9	0.5	16.25 15.75	16.25 15.75	1.0	0.75 0.45	0.2	0.08	0.08	1.15 0.85	1.15 0.85	7° 0°

**Note**  
1. Plastic or metal protrusions of 0.25 mm maximum per side are not included.

OUTLINE VERSION	REFERENCES				EUROPEAN PROJECTION	ISSUE DATE
	IEC	JEDEC	EIAJ			
SOT407-1	136E20	MS-026				00-01-19 00-02-01

Digital PC-camera signal processor including microcontroller and USB interface

SAA8116

TFBGA112: plastic thin fine-pitch ball grid array package; 112 balls; body 7 x 7 x 0.8 mm

SOT630-1

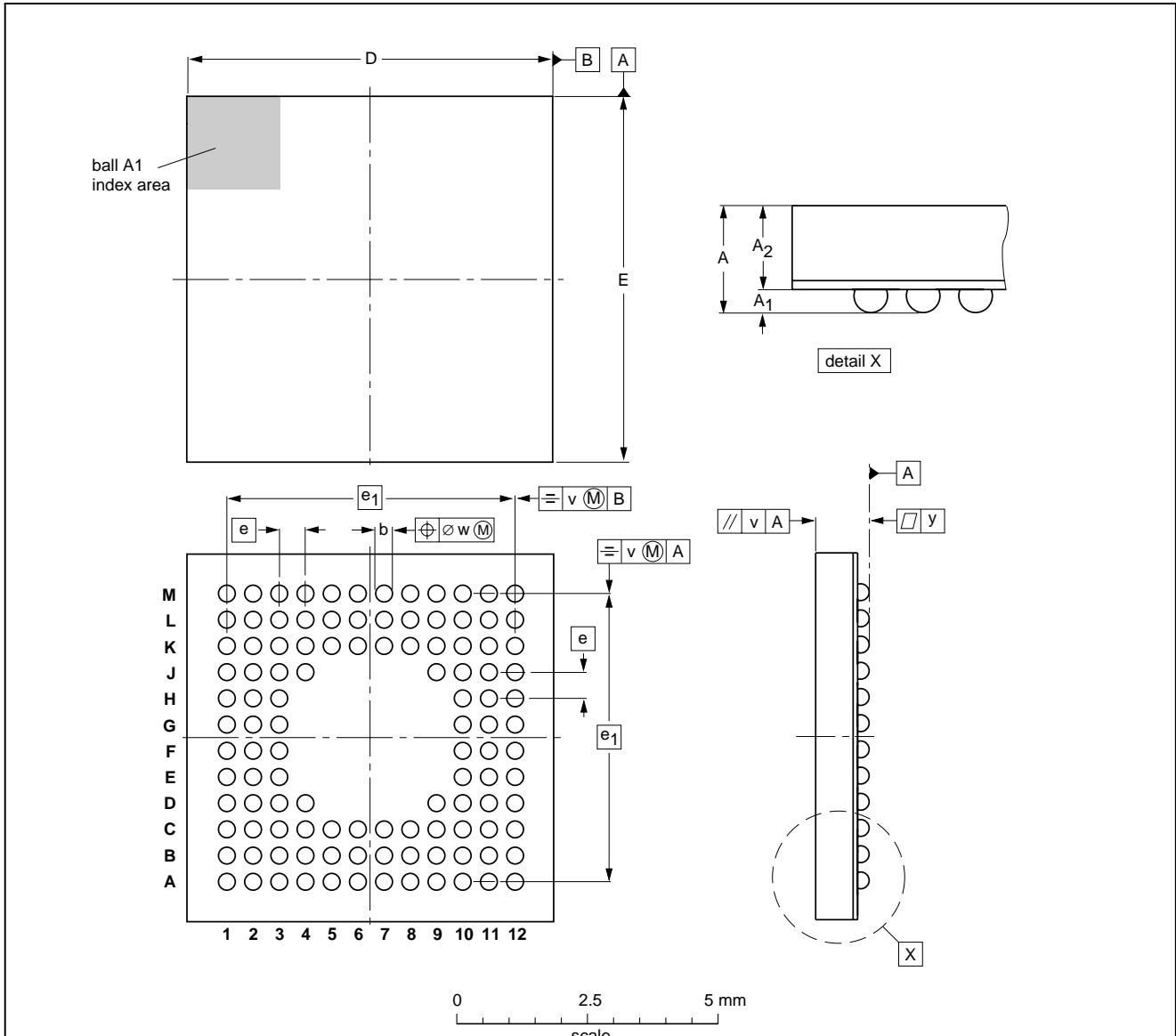

DIMENSIONS (mm are the original dimensions)

UNIT	A max.	A <sub>1</sub>	A <sub>2</sub>	b	D	E	e	e <sub>1</sub>	v	w	y	y <sub>1</sub>
mm	1.12	0.28 0.16	0.84 0.76	0.37 0.27	7.1 6.9	7.1 6.9	0.5	5.5	0.1	0.15	0.12	0.1

OUTLINE VERSION	REFERENCES				EUROPEAN PROJECTION	ISSUE DATE
	IEC	JEDEC	EIAJ			
SOT630-1		MO-195				00-07-20



## Digital PC-camera signal processor including microcontroller and USB interface

SAA8116

### SOLDERING

#### Introduction to soldering surface mount packages

This text gives a very brief insight to a complex technology. A more in-depth account of soldering ICs can be found in our *"Data Handbook IC26; Integrated Circuit Packages"* (document order number 9398 652 90011).

There is no soldering method that is ideal for all surface mount IC packages. Wave soldering can still be used for certain surface mount ICs, but it is not suitable for fine pitch SMDs. In these situations reflow soldering is recommended.

#### Reflow soldering

Reflow soldering requires solder paste (a suspension of fine solder particles, flux and binding agent) to be applied to the printed-circuit board by screen printing, stencilling or pressure-syringe dispensing before package placement.

Several methods exist for reflowing; for example, convection or convection/infrared heating in a conveyor type oven. Throughput times (preheating, soldering and cooling) vary between 100 and 200 seconds depending on heating method.

Typical reflow peak temperatures range from 215 to 250 °C. The top-surface temperature of the packages should preferably be kept below 220 °C for thick/large packages, and below 235 °C for small/thin packages.

#### Wave soldering

Conventional single wave soldering is not recommended for surface mount devices (SMDs) or printed-circuit boards with a high component density, as solder bridging and non-wetting can present major problems.

To overcome these problems the double-wave soldering method was specifically developed.

If wave soldering is used the following conditions must be observed for optimal results:

- Use a double-wave soldering method comprising a turbulent wave with high upward pressure followed by a smooth laminar wave.
- For packages with leads on two sides and a pitch (e):
  - larger than or equal to 1.27 mm, the footprint longitudinal axis is **preferred** to be parallel to the transport direction of the printed-circuit board;
  - smaller than 1.27 mm, the footprint longitudinal axis **must** be parallel to the transport direction of the printed-circuit board.

The footprint must incorporate solder thieves at the downstream end.

- For packages with leads on four sides, the footprint must be placed at a 45° angle to the transport direction of the printed-circuit board. The footprint must incorporate solder thieves downstream and at the side corners.

During placement and before soldering, the package must be fixed with a droplet of adhesive. The adhesive can be applied by screen printing, pin transfer or syringe dispensing. The package can be soldered after the adhesive is cured.

Typical dwell time is 4 seconds at 250 °C.

A mildly-activated flux will eliminate the need for removal of corrosive residues in most applications.

#### Manual soldering

Fix the component by first soldering two diagonally-opposite end leads. Use a low voltage (24 V or less) soldering iron applied to the flat part of the lead. Contact time must be limited to 10 seconds at up to 300 °C.

When using a dedicated tool, all other leads can be soldered in one operation within 2 to 5 seconds between 270 and 320 °C.

# Digital PC-camera signal processor including microcontroller and USB interface

SAA8116

## Suitability of surface mount IC packages for wave and reflow soldering methods

PACKAGE	SOLDERING METHOD	
	WAVE	REFLOW <sup>(1)</sup>
BGA, LFBGA, SQFP, TFBGA	not suitable	suitable
HBCC, HLQFP, HSQFP, HSOP, HTQFP, HTSSOP, HVQFN, SMS	not suitable <sup>(2)</sup>	suitable
PLCC <sup>(3)</sup> , SO, SOJ	suitable	suitable
LQFP, QFP, TQFP	not recommended <sup>(3)(4)</sup>	suitable
SSOP, TSSOP, VSO	not recommended <sup>(5)</sup>	suitable

### Notes

- All surface mount (SMD) packages are moisture sensitive. Depending upon the moisture content, the maximum temperature (with respect to time) and body size of the package, there is a risk that internal or external package cracks may occur due to vaporization of the moisture in them (the so called popcorn effect). For details, refer to the Drypack information in the "Data Handbook IC26; Integrated Circuit Packages; Section: Packing Methods".
- These packages are not suitable for wave soldering as a solder joint between the printed-circuit board and heatsink (at bottom version) can not be achieved, and as solder may stick to the heatsink (on top version).
- If wave soldering is considered, then the package must be placed at a 45° angle to the solder wave direction. The package footprint must incorporate solder thieves downstream and at the side corners.
- Wave soldering is only suitable for LQFP, TQFP and QFP packages with a pitch (e) equal to or larger than 0.8 mm; it is definitely not suitable for packages with a pitch (e) equal to or smaller than 0.65 mm.
- Wave soldering is only suitable for SSOP and TSSOP packages with a pitch (e) equal to or larger than 0.65 mm; it is definitely not suitable for packages with a pitch (e) equal to or smaller than 0.5 mm.

### DATA SHEET STATUS

DATA SHEET STATUS <sup>(1)</sup>	PRODUCT STATUS <sup>(2)</sup>	DEFINITIONS
Objective data	Development	This data sheet contains data from the objective specification for product development. Philips Semiconductors reserves the right to change the specification in any manner without notice.
Preliminary data	Qualification	This data sheet contains data from the preliminary specification. Supplementary data will be published at a later date. Philips Semiconductors reserves the right to change the specification without notice, in order to improve the design and supply the best possible product.
Product data	Production	This data sheet contains data from the product specification. Philips Semiconductors reserves the right to make changes at any time in order to improve the design, manufacturing and supply. Changes will be communicated according to the Customer Product/Process Change Notification (CPCN) procedure SNW-SQ-650A.

### Notes

- Please consult the most recently issued data sheet before initiating or completing a design.
- The product status of the device(s) described in this data sheet may have changed since this data sheet was published. The latest information is available on the Internet at URL <http://www.semiconductors.philips.com>.

## Digital PC-camera signal processor including microcontroller and USB interface

SAA8116

### DEFINITIONS

**Short-form specification** — The data in a short-form specification is extracted from a full data sheet with the same type number and title. For detailed information see the relevant data sheet or data handbook.

**Limiting values definition** — Limiting values given are in accordance with the Absolute Maximum Rating System (IEC 60134). Stress above one or more of the limiting values may cause permanent damage to the device. These are stress ratings only and operation of the device at these or at any other conditions above those given in the Characteristics sections of the specification is not implied. Exposure to limiting values for extended periods may affect device reliability.

**Application information** — Applications that are described herein for any of these products are for illustrative purposes only. Philips Semiconductors make no representation or warranty that such applications will be suitable for the specified use without further testing or modification.

### DISCLAIMERS

**Life support applications** — These products are not designed for use in life support appliances, devices, or systems where malfunction of these products can reasonably be expected to result in personal injury. Philips Semiconductors customers using or selling these products for use in such applications do so at their own risk and agree to fully indemnify Philips Semiconductors for any damages resulting from such application.

**Right to make changes** — Philips Semiconductors reserves the right to make changes, without notice, in the products, including circuits, standard cells, and/or software, described or contained herein in order to improve design and/or performance. Philips Semiconductors assumes no responsibility or liability for the use of any of these products, conveys no licence or title under any patent, copyright, or mask work right to these products, and makes no representations or warranties that these products are free from patent, copyright, or mask work right infringement, unless otherwise specified.

### PURCHASE OF PHILIPS I<sup>2</sup>C COMPONENTS



Purchase of Philips I<sup>2</sup>C components conveys a license under the Philips' I<sup>2</sup>C patent to use the components in the I<sup>2</sup>C system provided the system conforms to the I<sup>2</sup>C specification defined by Philips. This specification can be ordered using the code 9398 393 40011.

# Philips Semiconductors – a worldwide company

**Argentina:** see South America

**Australia:** 3 Figtree Drive, HOMEBUSH, NSW 2140,  
Tel. +61 2 9704 8141, Fax. +61 2 9704 8139

**Austria:** Computerstr. 6, A-1101 WIEN, P.O. Box 213,  
Tel. +43 1 60 101 1248, Fax. +43 1 60 101 1210

**Belarus:** Hotel Minsk Business Center, Bld. 3, r. 1211, Volodarski Str. 6,  
220050 MINSK, Tel. +375 172 20 0733, Fax. +375 172 20 0773

**Belgium:** see The Netherlands

**Brazil:** see South America

**Bulgaria:** Philips Bulgaria Ltd., Energoproject, 15th floor,  
51 James Bourchier Blvd., 1407 SOFIA,  
Tel. +359 2 68 9211, Fax. +359 2 68 9102

**Canada:** PHILIPS SEMICONDUCTORS/COMPONENTS,  
Tel. +1 800 234 7381, Fax. +1 800 943 0087

**China/Hong Kong:** 501 Hong Kong Industrial Technology Centre,  
72 Tat Chee Avenue, Kowloon Tong, HONG KONG,  
Tel. +852 2319 7888, Fax. +852 2319 7700

**Colombia:** see South America

**Czech Republic:** see Austria

**Denmark:** Sydhavnsgade 23, 1780 COPENHAGEN V,  
Tel. +45 33 29 3333, Fax. +45 33 29 3905

**Finland:** Sinikalliontie 3, FIN-02630 ESPOO,  
Tel. +358 9 615 800, Fax. +358 9 6158 0920

**France:** 7 - 9 Rue du Mont Valérien, BP317, 92156 SURESNES Cedex,  
Tel. +33 1 4728 6600, Fax. +33 1 4728 6638

**Germany:** Hammerbrookstraße 69, D-20097 HAMBURG,  
Tel. +49 40 2353 60, Fax. +49 40 2353 6300

**Hungary:** Philips Hungary Ltd., H-1119 Budapest, Fehervari ut 84/A,  
Tel: +36 1 382 1700, Fax: +36 1 382 1800

**India:** Philips INDIA Ltd, Band Box Building, 2nd floor,  
254-D, Dr. Annie Besant Road, Worli, MUMBAI 400 025,  
Tel. +91 22 493 8541, Fax. +91 22 493 0966

**Indonesia:** PT Philips Development Corporation, Semiconductors Division,  
Gedung Philips, Jl. Buncit Raya Kav.99-100, JAKARTA 12510,  
Tel. +62 21 794 0040 ext. 2501, Fax. +62 21 794 0080

**Ireland:** Newstead, Clonskeagh, DUBLIN 14,  
Tel. +353 1 7640 000, Fax. +353 1 7640 200

**Israel:** RAPAC Electronics, 7 Kehilat Saloniki St, PO Box 18053,  
TEL AVIV 61180, Tel. +972 3 645 0444, Fax. +972 3 649 1007

**Italy:** PHILIPS SEMICONDUCTORS, Via Casati, 23 - 20052 MONZA (MI),  
Tel. +39 039 203 6838, Fax +39 039 203 6800

**Japan:** Philips Bldg 13-37, Kohnan 2-chome, Minato-ku,  
TOKYO 108-8507, Tel. +81 3 3740 5130, Fax. +81 3 3740 5057

**Korea:** Philips House, 260-199 Itaewon-dong, Yongsan-ku, SEOUL,  
Tel. +82 2 709 1412, Fax. +82 2 709 1415

**Malaysia:** No. 76 Jalan Universiti, 46200 PETALING JAYA, SELANGOR,  
Tel. +60 3 750 5214, Fax. +60 3 757 4880

**Mexico:** 5900 Gateway East, Suite 200, EL PASO, TEXAS 79905,  
Tel. +9-5 800 234 7381, Fax +9-5 800 943 0087

**Middle East:** see Italy

**Netherlands:** Postbus 90050, 5600 PB EINDHOVEN, Bldg. VB,  
Tel. +31 40 27 82785, Fax. +31 40 27 88399

**New Zealand:** 2 Wagener Place, C.P.O. Box 1041, AUCKLAND,  
Tel. +64 9 849 4160, Fax. +64 9 849 7811

**Norway:** Box 1, Manglerud 0612, OSLO,  
Tel. +47 22 74 8000, Fax. +47 22 74 8341

**Pakistan:** see Singapore

**Philippines:** Philips Semiconductors Philippines Inc.,  
106 Valero St. Salcedo Village, P.O. Box 2108 MCC, MAKATI,  
Metro MANILA, Tel. +63 2 816 6380, Fax. +63 2 817 3474

**Poland:** Al.Jerozolimskie 195 B, 02-222 WARSAW,  
Tel. +48 22 5710 000, Fax. +48 22 5710 001

**Portugal:** see Spain

**Romania:** see Italy

**Russia:** Philips Russia, Ul. Usatcheva 35A, 119048 MOSCOW,  
Tel. +7 095 755 6918, Fax. +7 095 755 6919

**Singapore:** Lorong 1, Toa Payoh, SINGAPORE 319762,  
Tel. +65 350 2538, Fax. +65 251 6500

**Slovakia:** see Austria

**Slovenia:** see Italy

**South Africa:** S.A. PHILIPS Pty Ltd., 195-215 Main Road Martindale,  
2092 JOHANNESBURG, P.O. Box 58088 Newville 2114,  
Tel. +27 11 471 5401, Fax. +27 11 471 5398

**South America:** Al. Vicente Pinzon, 173, 6th floor,  
04547-130 SÃO PAULO, SP, Brazil,  
Tel. +55 11 821 2333, Fax. +55 11 821 2382

**Spain:** Balmes 22, 08007 BARCELONA,  
Tel. +34 93 301 6312, Fax. +34 93 301 4107

**Sweden:** Kottbygatan 7, Akalla, S-16485 STOCKHOLM,  
Tel. +46 8 5985 2000, Fax. +46 8 5985 2745

**Switzerland:** Allmendstrasse 140, CH-8027 ZÜRICH,  
Tel. +41 1 488 2741 Fax. +41 1 488 3263

**Taiwan:** Philips Semiconductors, 5F, No. 96, Chien Kuo N. Rd., Sec. 1,  
TAIPEI, Taiwan Tel. +886 2 2134 2451, Fax. +886 2 2134 2874

**Thailand:** PHILIPS ELECTRONICS (THAILAND) Ltd.,  
60/14 MOO 11, Bangna Trad Road KM. 3, Bagna, BANGKOK 10260,  
Tel. +66 2 361 7910, Fax. +66 2 398 3447

**Turkey:** Yukari Dudullu, Org. San. Blg., 2.Cad. Nr. 28 81260 Umraniye,  
ISTANBUL, Tel. +90 216 522 1500, Fax. +90 216 522 1813

**Ukraine:** PHILIPS UKRAINE, 4 Patrice Lumumba str., Building B, Floor 7,  
252042 KIEV, Tel. +380 44 264 2776, Fax. +380 44 268 0461

**United Kingdom:** Philips Semiconductors Ltd., 276 Bath Road, Hayes,  
MIDDLESEX UB3 5BX, Tel. +44 208 730 5000, Fax. +44 208 754 8421

**United States:** 811 East Arques Avenue, SUNNYVALE, CA 94088-3409,  
Tel. +1 800 234 7381, Fax. +1 800 943 0087

**Uruguay:** see South America

**Vietnam:** see Singapore

**Yugoslavia:** PHILIPS, Trg N. Pasica 5/v, 11000 BEOGRAD,  
Tel. +381 11 3341 299, Fax.+381 11 3342 553

**For all other countries apply to:** Philips Semiconductors,  
Marketing Communications, Building BE-p, P.O. Box 218, 5600 MD EINDHOVEN,  
The Netherlands, Fax. +31 40 27 24825

**Internet:** <http://www.semiconductors.philips.com>

© Philips Electronics N.V. 2001

SCA 72

All rights are reserved. Reproduction in whole or in part is prohibited without the prior written consent of the copyright owner.

The information presented in this document does not form part of any quotation or contract, is believed to be accurate and reliable and may be changed without notice. No liability will be accepted by the publisher for any consequence of its use. Publication thereof does not convey nor imply any license under patent- or other industrial or intellectual property rights.

Printed in The Netherlands

753505/03/pp60

Date of release: 2001 May 04

Document order number: 9397 750 08198

*Let's make things better.*

**Philips**  
Semiconductors



**PHILIPS**