

5-Phase Stepper Motor Driver ICs

■Absolute Maximum Ratings

(T_a=25°C)

Part No.	Parameter	Symbol	Ratings	Units
SI-7502	Motor supply voltage	V _{CC}	44	V
	Auxiliary supply voltage	V _S	15	V
	Control voltage	V _b	7	V
	Reference voltage	V _{ref}	1.5	V
	Detection voltage	V _{RS}	5	V
	Power dissipation	P _D	1	W
	Ambient operating temperature	T _{OP}	0 to +65	°C
SLA5011	Drain -Source voltage	V _{DSS}	60	V
	Drain current	I _D	±5	A
	Avalanche energy capability (Single pulse)	E _{AS}	2	mJ
	Power dissipation	P _T	35	W
	Channel temperature	T _{ch}	150	°C
	Storage temperature	T _{stg}	-40 to +150	°C
SLA6503	Collector-Base voltage	V _{CBO}	-60	V
	Collector-Emitter voltage	V _{CEO}	-60	V
	Emitter-Base voltage	V _{EBO}	-6	V
	Collector current	I _C	-3	A
	Collector current (Pulse)	I _{C (pulse)}	-6	A
	Base current	I _B	-1	A
	Power dissipation	P _T	35	W
	Junction temperature	T _J	150	°C
	Storage temperature	T _{stg}	-40 to +150	°C

■Electrical Characteristics

(T_a=25°C)

Part No.	Parameter	Symbol	Limits			Units	Conditions
			min	typ	max		
SI-7502	Supply current	I _{CC}			40	mA	V _{CC} =42V, V _b =5.5V
		I _S			12.5	mA	V _S =12.5V
		I _b			50	mA	V _b =5.5V
	Input current	I _{IU-L} , I _{IL-L}			1.6	mA	V _{IU} =V _{IL} =0.4V
	Upper drive circuit drive current	I _{OU-on}	8		11	mA	V _b =5V, AIU to EIU pin open
		I _{OU-off}			10	μA	V _b =5V
	Lower drive circuit voltage	V _{OL-on}	V _S -1.5			V	V _b =5V, AIL to EIL pin open
		V _{OL-off}			1.5	V	V _b =5V
	Oscillation frequency	F	20		30	kHz	V _b =5V
Detection voltage	V _{RS}	0.8		1.05	V	V _b =5V, V _{REF} pin open	
SLA5011	Gate threshold voltage	V _{TH}	2.0		4.0	V	V _{DSS} =10V, I _D =250μA
	Forward Transconductance	R _{e (yts)}	2.2	3.3		S	V _{DSS} =10V, I _D =5A
	DC ON-resistance	R _{DS (ON)}		0.17	0.22	Ω	V _{GS} =10V, I _D =5A
	Input capacitance	C _{ISS}		300		pF	V _{DSS} =25V, f=1.0MHz, V _{GS} =0V
	Output capacitance	C _{OSS}		160		pF	
	Di forward voltage between source and drain	V _{SD}		1.1	1.5	V	I _{SD} =5A
Di reverse recovery time between source and drain	t _{rr}		150		ns	I _{SD} =±100mA	
SLA6503	Collector cut-off current	I _{CBO}			-10	μA	V _{CB} =-60V
	Collector-emitter voltage	V _{CEO}	-60			V	I _C =-10mA
	DC current gain	h _{FE}	2000				V _{CE} =-4V, I _C =-3A
	Collector emitter saturation voltage	V _{CE (sat)}			1.5	V	I _C =-3A, I _B =-6mA

Internal Block Diagram (Dotted Line)

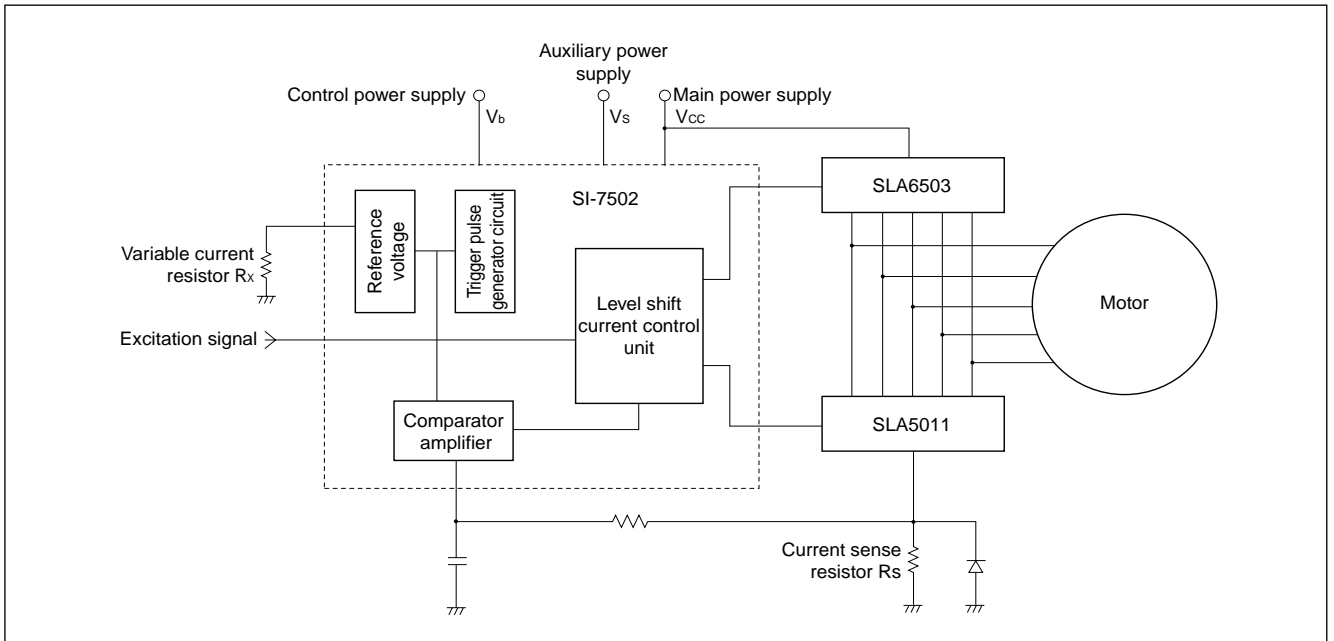

Equivalent Circuit Diagram

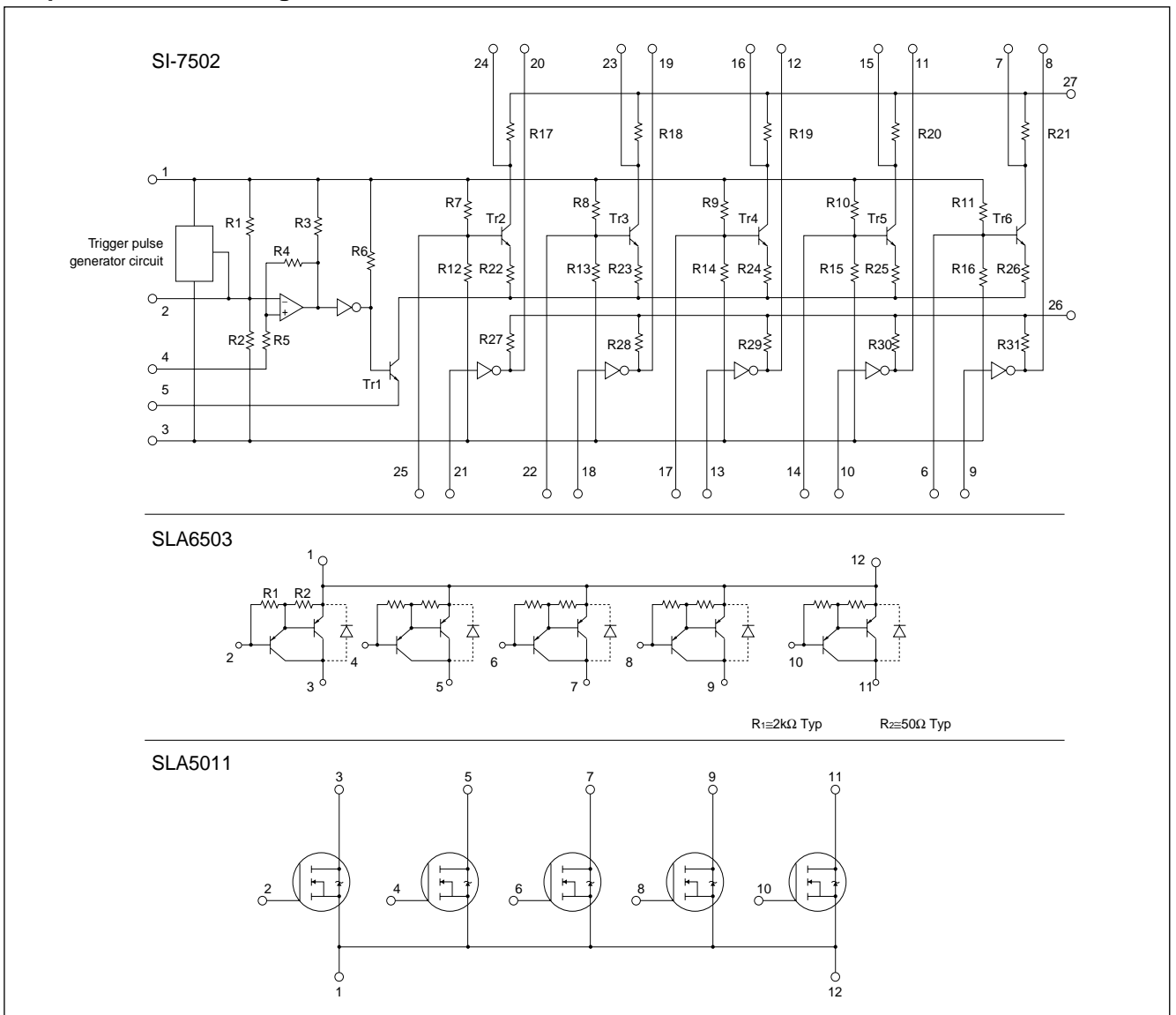

■Diagram of Standard External Circuit

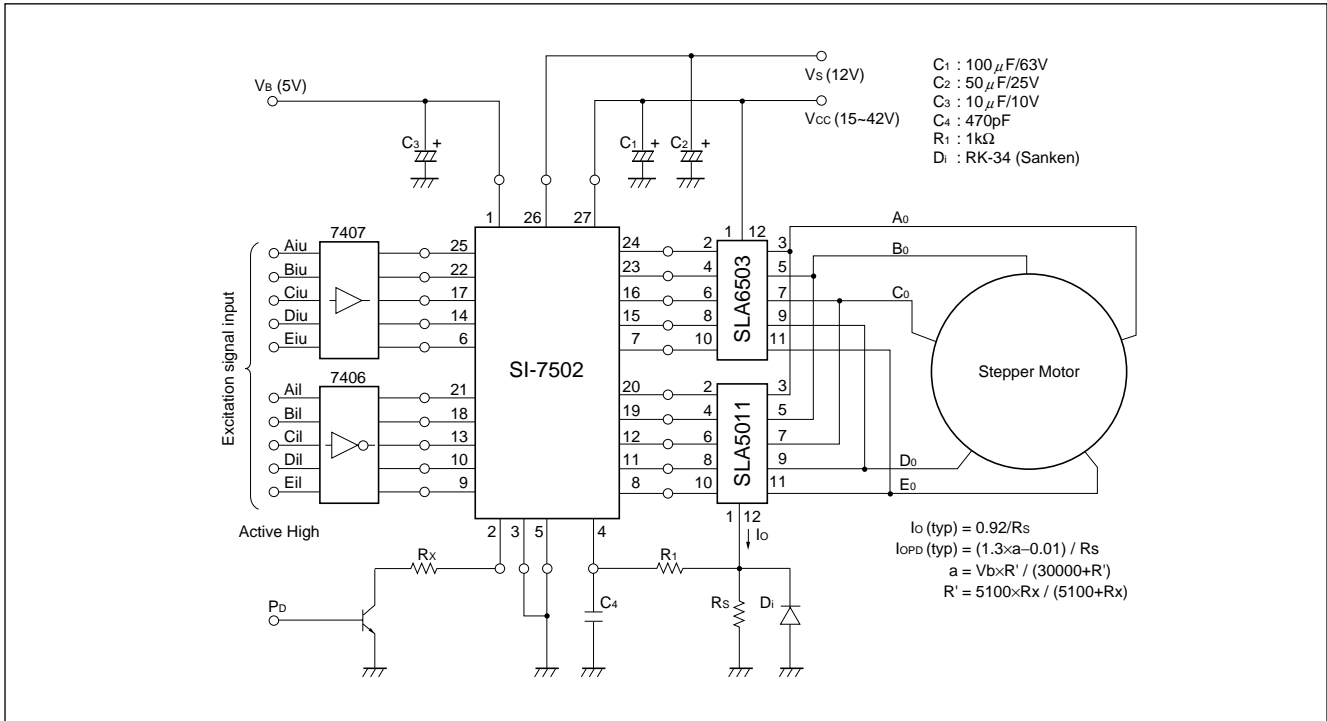

■External Dimensions

(Unit: mm)

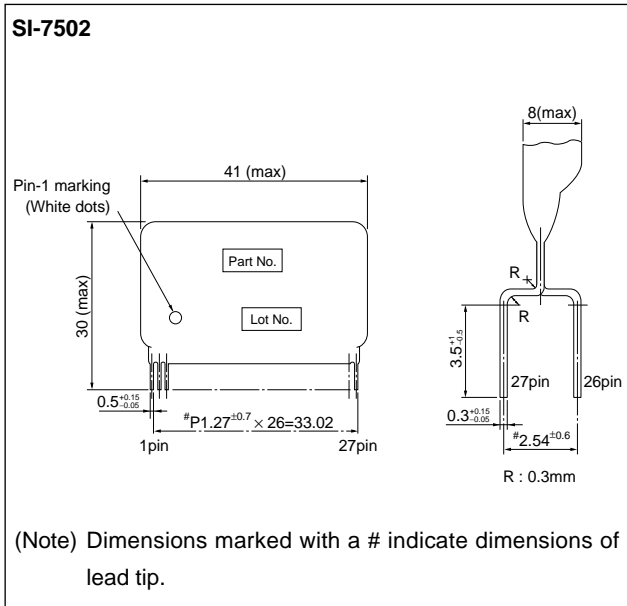

■External Dimensions

(Unit: mm)

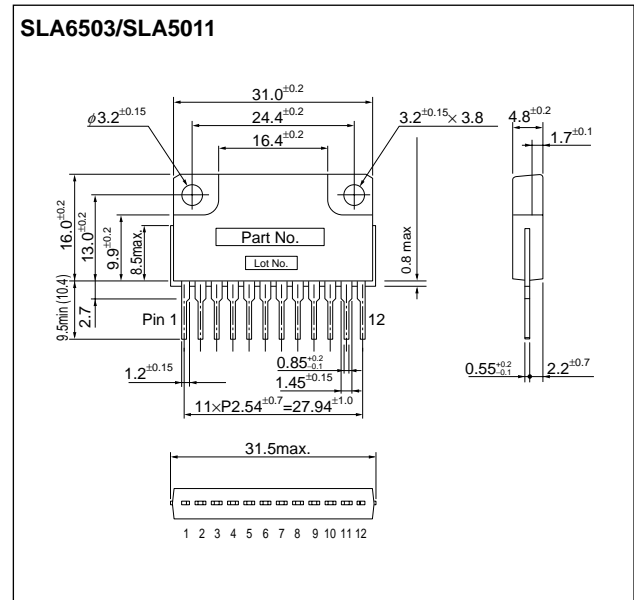

Application Notes

■Determining the Output Current I_o (Control Current)

The main factors that determine the output current are current sense resistor R_s , supply voltage V_b , and variable current resistor R_x .

(1) Normal mode

To operate a motor at the maximum current level, set R_x to infinity (open).

From Fig. A, when the maximum current ripple is designated as I_{OH} , its value will be,

$$I_{OH} = \frac{V_{RSH}}{R_s} \dots\dots\dots (1)$$

V_{RSH} can be calculated as follows:

$$V_{RSH} = 0.19 \times V_b - 0.03 \text{ (center value)} \dots\dots\dots (2)$$

From equations (1) and (2), the output current I_{OH} can be calculated as follows:

$$I_{OH} = \frac{1}{R_s} (0.19 \times V_b - 0.03)$$

The relationship between I_{OH} and R_s is shown in Fig. B.

(2) Power down mode

When an external resistor R_x is connected, V_{RSH} changes as shown in Fig. C even when R_s is retained. Obtain a power down output current I_{OHPD} from Fig. C and equation (1).

■Relation between Output Current I_o (Control Current) and Motor Winding Current I_{OM}

The SI-7502 uses the total current control system; therefore, the output current I_o is different from the motor winding current. In a general pentagonal driving system, the current flows as shown in Figure D. The relation between I_o and I_{OM} is as follows:

$$I_o = 4 \times I_{OM}$$

With some driving systems, the relation can also be as follows:

$$I_o = 2 \times I_{OM}$$

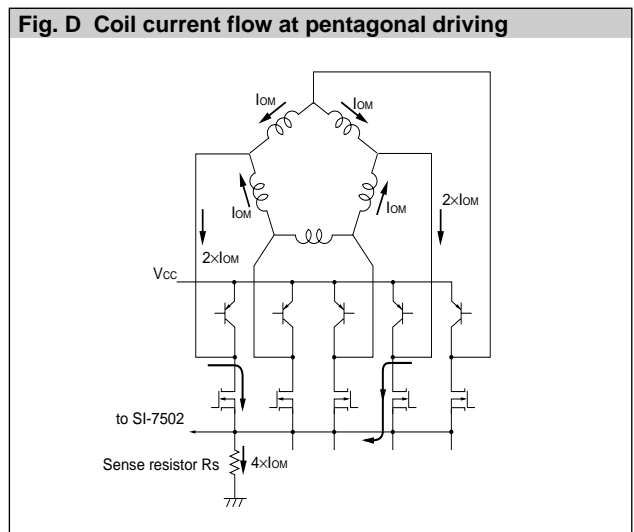
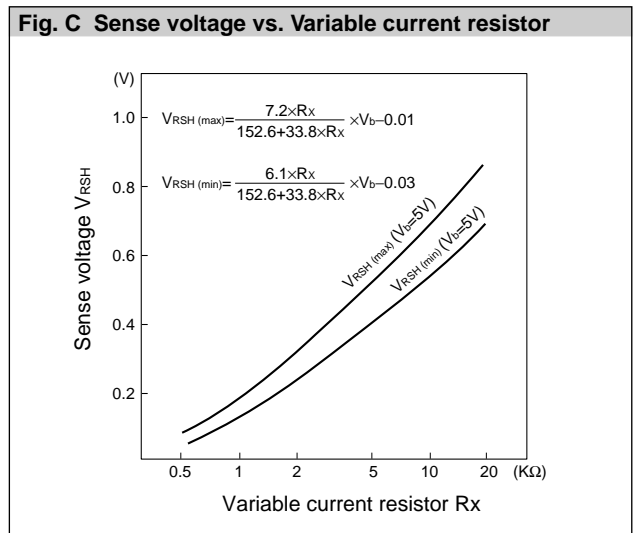
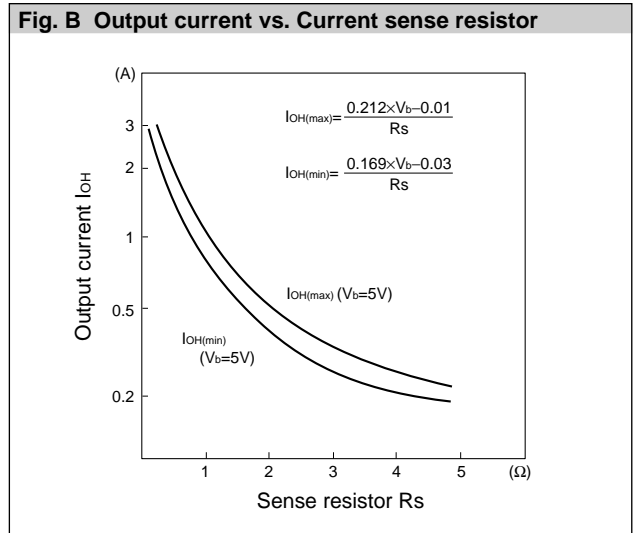
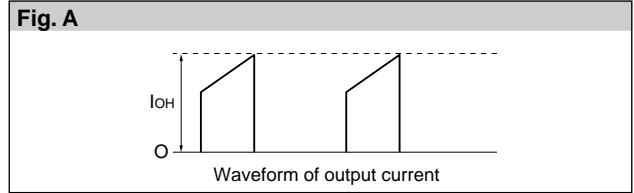

■Motor Connection

The 5-phase stepper motor supports various driving systems and the motor connection varies depending on the driving system used.

Use of the motor with some driving systems may be restricted by patents. Therefore, be sure to ask the motor manufacturer about the motor connection and driving system to be used.

■Thermal design

The driver (SLA5011/SLA6503) dissipation varies depending on a driving system used even if the output currents (control current) are the same. Therefore, measure the temperature rise of the driver under the actual operating conditions to determine the size of the heatsink.

Figure E shows an SLA5011/SLA6503 derating curve. This derating curve indicates $T_j=150^{\circ}\text{C}$; however, when using this device, allow sufficient margin when selecting a heatsink so that $T_c \leq 100^{\circ}\text{C}$ (Al FIN temperature on the back of the SLA) is obtained.

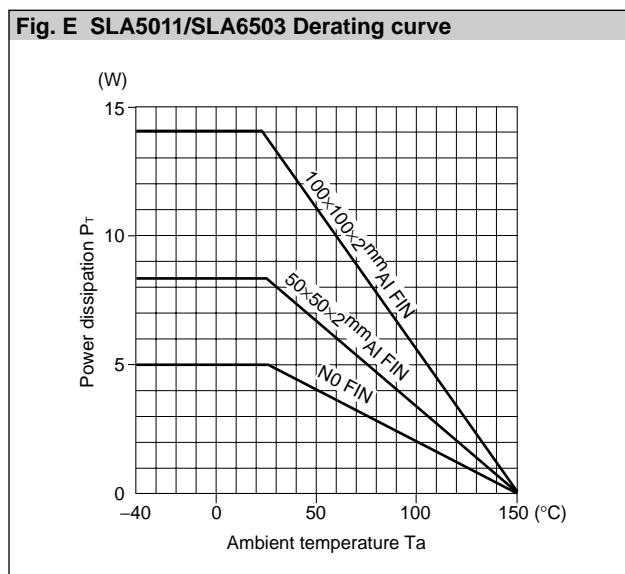

SI-7502

■Handling Precautions

Refer to the product specifications.

Solvents- Do not use the following solvents:

Substances that can dissolve the package	Chlorine-based solvents: Trichloroethylene, Trichloroethane, etc. Aromatic hydrogen compounds: Benzene, Toluene, Xylene, etc. Keton and Acetone group solvents
Substances that can weaken the package	Gasoline, Benzine, Kerosene, etc.