

SN74ACT1073

16-BIT BUS-TERMINATION ARRAY WITH BUS-HOLD FUNCTION

SCAS193A – MARCH 1992 – REVISED NOVEMBER 2002

- Designed to Ensure Defined Voltage Levels on Floating Bus Lines in CMOS Systems
- 4.5-V to 5.5-V V_{CC} Operation
- Inputs Accept Voltages to 5.5 V
- Reduces Undershoot and Overshoot Caused By Line Reflections
- Repetitive Peak Forward Current . . . $I_{FRM} = 100$ mA
- Inputs Are TTL-Voltage Compatible
- Low Power Consumption (Like CMOS)
- Center-Pin V_{CC} and GND Configuration Minimizes High-Speed Switching Noise
- ESD Protection Exceeds JESD 22
 - 2000-V Human-Body Model (A114-A)
 - 200-V Machine Model (A115-A)

DW OR NS PACKAGE
(TOP VIEW)

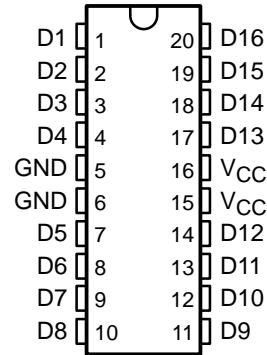

description/ordering information

This device is designed to terminate bus lines in CMOS systems. The integrated low-impedance diodes clamp the voltage of undershoots and overshoots caused by line reflections and ensure signal integrity. The device also contains a bus-hold function that consists of a CMOS-buffer stage with a high-resistance feedback path between its output and its input. The SN74ACT1073 prevents bus lines from floating without using pullup or pulldown resistors.

The high-impedance inputs of these internal buffers are connected to the input terminals of the device. The feedback path on each internal buffer stage keeps a bus line tied to the bus holder at the last valid logic state generated by an active driver before the bus switches to the high-impedance state.

ORDERING INFORMATION

T _A	PACKAGE†		ORDERABLE PART NUMBER	TOP-SIDE MARKING
–40°C to 85°C	SOIC – DW	Tube	SN74ACT1073DW	ACT1073
		Tape and reel	SN74ACT1073DWR	
	SOP – NS	Tape and reel	SN74ACT1073NSR	ACT1073

† Package drawings, standard packing quantities, thermal data, symbolization, and PCB design guidelines are available at www.ti.com/sc/package.



Please be aware that an important notice concerning availability, standard warranty, and use in critical applications of Texas Instruments semiconductor products and disclaimers thereto appears at the end of this data sheet.

PRODUCTION DATA information is current as of publication date. Products conform to specifications per the terms of Texas Instruments standard warranty. Production processing does not necessarily include testing of all parameters.



POST OFFICE BOX 655303 • DALLAS, TEXAS 75265

Copyright © 2002, Texas Instruments Incorporated

SN74ACT1073 16-BIT BUS-TERMINATION ARRAY WITH BUS-HOLD FUNCTION

SCAS193A – MARCH 1992 – REVISED NOVEMBER 2002

logic diagram, one of sixteen channels (positive logic)

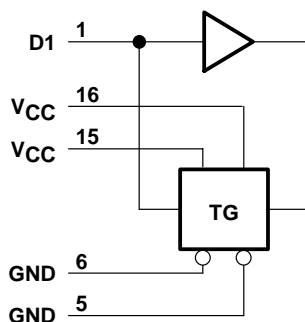

absolute maximum ratings over operating free-air temperature range (unless otherwise noted)†

Supply voltage range, V_{CC}	-0.5 V to 7 V
Input voltage range, V_I (see Note 1)	-0.5 V to $V_{CC} + 0.5$ V
Continuous input clamp current, I_{IK} ($V_I < 0$ or $V_I > V_{CC}$)	± 20 mA
Positive-peak input clamp current, I_{IK} ($V_I > V_{CC}$) ($t_w < 1 \mu s$, duty cycle < 20%)	100 mA
Negative-peak input clamp current, I_{IK} ($V_I < 0$) ($t_w < 1 \mu s$, duty cycle < 20%)	-100 mA
Package thermal impedance, θ_{JA} (see Note 2): DW package	58°C/W
	NS package	60°C/W
Storage temperature range, T_{stg}	-65°C to 150°C

† Stresses beyond those listed under “absolute maximum ratings” may cause permanent damage to the device. These are stress ratings only, and functional operation of the device at these or any other conditions beyond those indicated under “recommended operating conditions” is not implied. Exposure to absolute-maximum-rated conditions for extended periods may affect device reliability.

- NOTE 1: The input negative-voltage rating may be exceeded if the input clamp-current rating is observed.
2. The package thermal impedance is calculated in accordance with JESD 51-7.

recommended operating conditions (see Note 3)

		MIN	MAX	UNIT
V_{CC}	Supply voltage	4.5	5.5	V
V_{IH}	High-level input voltage	2.5		V
V_{IL}	Low-level input voltage		0.8	V
V_I	Input voltage	0	V_{CC}	V
T_A	Operating free-air temperature	-40	85	°C

NOTE 3: All unused inputs of the device must be held at V_{CC} or GND to ensure proper device operation. Refer to the TI application report, *Implications of Slow or Floating CMOS Inputs*, literature number SCBA004.



SN74ACT1073
16-BIT BUS-TERMINATION ARRAY
WITH BUS-HOLD FUNCTION

SCAS193A – MARCH 1992 – REVISED NOVEMBER 2002

electrical characteristics over recommended operating free-air temperature range (unless otherwise noted)

PARAMETER	TEST CONDITIONS	T _A = 25°C			MIN	MAX	UNIT
		MIN	TYP†	MAX			
I _{IL}	V _{CC} = 4.5 to 5.5 V, V _I = 0.8 V	0.15	0.3	0.9	0.1	1	mA
I _{IH}	V _{CC} = 4.5 to 5.5 V, V _I = 2.5 V	-0.2	-0.5	-1.4	-0.15	-1.5	mA
V _{IKL}	I _{IN} = -18 mA			-1.5	-1.5		V
V _{IKH}	I _{IN} = 18 mA			V _{CC} +2	V _{CC} +2		V
I _{CC} ‡	V _{CC} = 5.5 V, Inputs open			4	40		μA
ΔI _{CC} §	One input at 3.4 V, Other inputs at V _{CC} or GND			0.9	1		mA
C _i	V _I = V _{CC} or GND		3				pF

† All typical values are at V_{CC} = 5 V.

‡ Inputs may be set high or low prior to the I_{CC} measurement.

§ This is the increase in supply current for each input that is at one of the specified TTL voltage levels, rather than 0 V or V_{CC}.

SN74ACT1073
16-BIT BUS-TERMINATION ARRAY
WITH BUS-HOLD FUNCTION

SCAS193A – MARCH 1992 – REVISED NOVEMBER 2002

TYPICAL CHARACTERISTICS

**FORWARD CURRENT
 vs
 INPUT VOLTAGE
 (UPPER CLAMPING DIODE)**

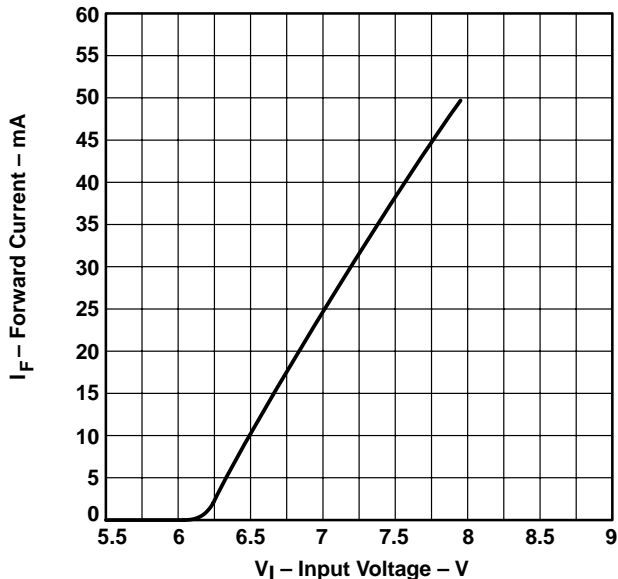

Figure 1

**FORWARD CURRENT
 vs
 INPUT VOLTAGE
 (LOWER CLAMPING DIODE)**

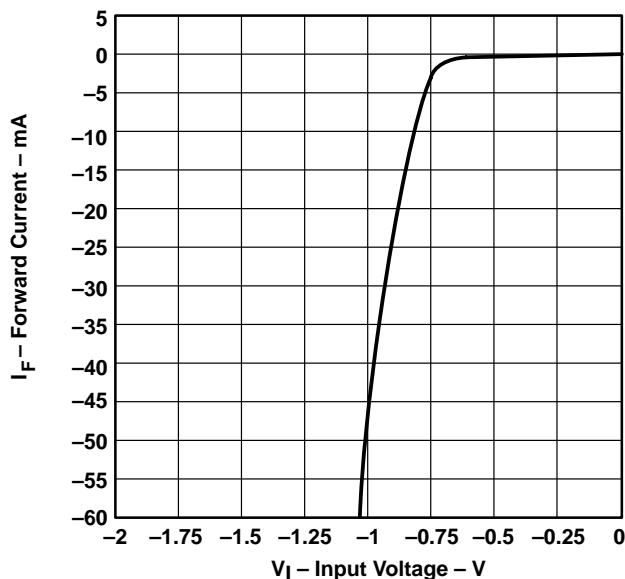

Figure 2

**INPUT CURRENT
 vs
 INPUT VOLTAGE**

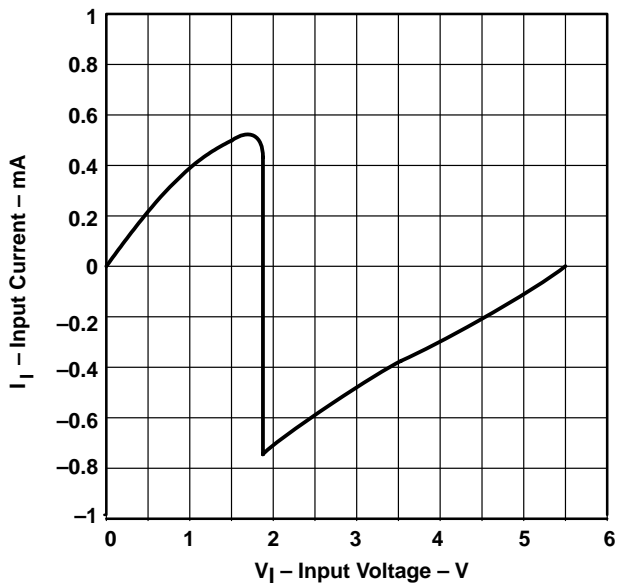

Figure 3

**SUPPLY CURRENT
 vs
 INPUT VOLTAGE**

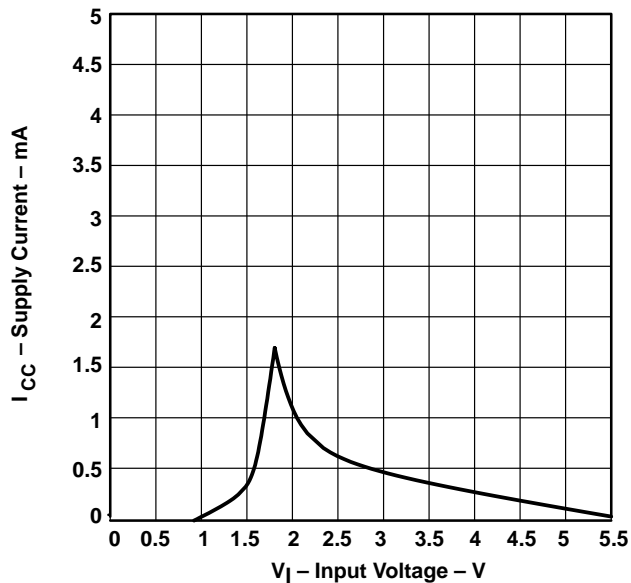

Figure 4



APPLICATION INFORMATION

The SN74ACT1073 terminates the output of a driving device and holds the input of the driven device at the logic level of the driver output prior to establishment of the high-impedance state on that output (see Figure 5).

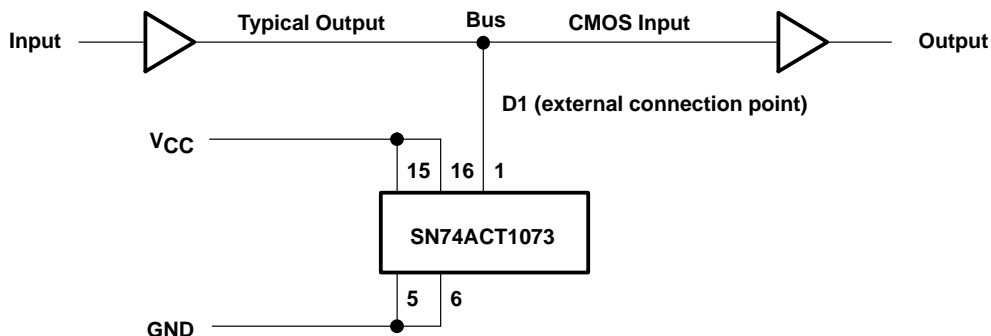

Figure 5. Bus-Hold Application

PACKAGING INFORMATION

Orderable Device	Status ⁽¹⁾	Package Type	Package Drawing	Pins	Package Qty	Eco Plan ⁽²⁾	Lead/Ball Finish	MSL Peak Temp ⁽³⁾
SN74ACT1073DW	ACTIVE	SOIC	DW	20	25	Green (RoHS & no Sb/Br)	CU NIPDAU	Level-1-260C-UNLIM
SN74ACT1073DWE4	ACTIVE	SOIC	DW	20	25	Green (RoHS & no Sb/Br)	CU NIPDAU	Level-1-260C-UNLIM
SN74ACT1073DWR	ACTIVE	SOIC	DW	20	2000	Green (RoHS & no Sb/Br)	CU NIPDAU	Level-1-260C-UNLIM
SN74ACT1073DWRE4	ACTIVE	SOIC	DW	20	2000	Green (RoHS & no Sb/Br)	CU NIPDAU	Level-1-260C-UNLIM
SN74ACT1073NSR	ACTIVE	SO	NS	20	2000	Green (RoHS & no Sb/Br)	CU NIPDAU	Level-1-260C-UNLIM
SN74ACT1073NSRE4	ACTIVE	SO	NS	20	2000	Green (RoHS & no Sb/Br)	CU NIPDAU	Level-1-260C-UNLIM

⁽¹⁾ The marketing status values are defined as follows:

ACTIVE: Product device recommended for new designs.

LIFEBUY: TI has announced that the device will be discontinued, and a lifetime-buy period is in effect.

NRND: Not recommended for new designs. Device is in production to support existing customers, but TI does not recommend using this part in a new design.

PREVIEW: Device has been announced but is not in production. Samples may or may not be available.

OBSOLETE: TI has discontinued the production of the device.

⁽²⁾ Eco Plan - The planned eco-friendly classification: Pb-Free (RoHS) or Green (RoHS & no Sb/Br) - please check <http://www.ti.com/productcontent> for the latest availability information and additional product content details.

TBD: The Pb-Free/Green conversion plan has not been defined.

Pb-Free (RoHS): TI's terms "Lead-Free" or "Pb-Free" mean semiconductor products that are compatible with the current RoHS requirements for all 6 substances, including the requirement that lead not exceed 0.1% by weight in homogeneous materials. Where designed to be soldered at high temperatures, TI Pb-Free products are suitable for use in specified lead-free processes.

Green (RoHS & no Sb/Br): TI defines "Green" to mean Pb-Free (RoHS compatible), and free of Bromine (Br) and Antimony (Sb) based flame retardants (Br or Sb do not exceed 0.1% by weight in homogeneous material)

⁽³⁾ MSL, Peak Temp. -- The Moisture Sensitivity Level rating according to the JEDEC industry standard classifications, and peak solder temperature.

Important Information and Disclaimer:The information provided on this page represents TI's knowledge and belief as of the date that it is provided. TI bases its knowledge and belief on information provided by third parties, and makes no representation or warranty as to the accuracy of such information. Efforts are underway to better integrate information from third parties. TI has taken and continues to take reasonable steps to provide representative and accurate information but may not have conducted destructive testing or chemical analysis on incoming materials and chemicals. TI and TI suppliers consider certain information to be proprietary, and thus CAS numbers and other limited information may not be available for release.

In no event shall TI's liability arising out of such information exceed the total purchase price of the TI part(s) at issue in this document sold by TI to Customer on an annual basis.

DW (R-PDSO-G20)

PLASTIC SMALL-OUTLINE PACKAGE



- NOTES:
- A. All linear dimensions are in inches (millimeters).
 - B. This drawing is subject to change without notice.
 - C. Body dimensions do not include mold flash or protrusion not to exceed 0.006 (0,15).
 - D. Falls within JEDEC MS-013 variation AC.

MECHANICAL DATA

NS (R-PDSO-G**)

PLASTIC SMALL-OUTLINE PACKAGE

14-PINS SHOWN



- NOTES:
- A. All linear dimensions are in millimeters.
 - B. This drawing is subject to change without notice.
 - C. Body dimensions do not include mold flash or protrusion, not to exceed 0,15.

IMPORTANT NOTICE

Texas Instruments Incorporated and its subsidiaries (TI) reserve the right to make corrections, modifications, enhancements, improvements, and other changes to its products and services at any time and to discontinue any product or service without notice. Customers should obtain the latest relevant information before placing orders and should verify that such information is current and complete. All products are sold subject to TI's terms and conditions of sale supplied at the time of order acknowledgment.

TI warrants performance of its hardware products to the specifications applicable at the time of sale in accordance with TI's standard warranty. Testing and other quality control techniques are used to the extent TI deems necessary to support this warranty. Except where mandated by government requirements, testing of all parameters of each product is not necessarily performed.

TI assumes no liability for applications assistance or customer product design. Customers are responsible for their products and applications using TI components. To minimize the risks associated with customer products and applications, customers should provide adequate design and operating safeguards.

TI does not warrant or represent that any license, either express or implied, is granted under any TI patent right, copyright, mask work right, or other TI intellectual property right relating to any combination, machine, or process in which TI products or services are used. Information published by TI regarding third-party products or services does not constitute a license from TI to use such products or services or a warranty or endorsement thereof. Use of such information may require a license from a third party under the patents or other intellectual property of the third party, or a license from TI under the patents or other intellectual property of TI.

Reproduction of information in TI data books or data sheets is permissible only if reproduction is without alteration and is accompanied by all associated warranties, conditions, limitations, and notices. Reproduction of this information with alteration is an unfair and deceptive business practice. TI is not responsible or liable for such altered documentation.

Resale of TI products or services with statements different from or beyond the parameters stated by TI for that product or service voids all express and any implied warranties for the associated TI product or service and is an unfair and deceptive business practice. TI is not responsible or liable for any such statements.

Following are URLs where you can obtain information on other Texas Instruments products and application solutions:

Products		Applications	
Amplifiers	amplifier.ti.com	Audio	www.ti.com/audio
Data Converters	dataconverter.ti.com	Automotive	www.ti.com/automotive
DSP	dsp.ti.com	Broadband	www.ti.com/broadband
Interface	interface.ti.com	Digital Control	www.ti.com/digitalcontrol
Logic	logic.ti.com	Military	www.ti.com/military
Power Mgmt	power.ti.com	Optical Networking	www.ti.com/opticalnetwork
Microcontrollers	microcontroller.ti.com	Security	www.ti.com/security
		Telephony	www.ti.com/telephony
		Video & Imaging	www.ti.com/video
		Wireless	www.ti.com/wireless

Mailing Address: Texas Instruments
Post Office Box 655303 Dallas, Texas 75265