

SN74ALS2240 OCTAL BUFFER AND LINE DRIVER/MOS DRIVER WITH 3-STATE OUTPUTS

SDAS268A – DECEMBER 1994 – REVISED NOVEMBER 1997

- Bidirectional Quadruple-Bus Transceivers for Driving MOS Devices
- I/O Ports Have 25-Ω Series Resistors, So No External Resistors Are Required
- Package Options Include Plastic Small-Outline (DW) Package and Standard Plastic (N) 300-mil DIPs

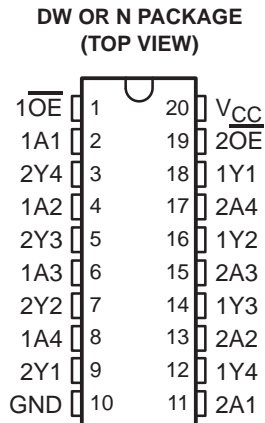

description

This octal buffer and line driver/MOS driver is designed to drive the capacitive inputs of MOS devices and to improve the performance and density of 3-state memory address drivers, clock drivers, and bus-oriented receivers and transmitters. This device features high fan-out and improved fan-in.

The SN74ALS2240 is characterized for operation from 0°C to 70°C.

**FUNCTION TABLE
(each buffer)**

| INPUTS | | OUTPUT |
|-----------------|---|--------|
| \overline{OE} | A | Y |
| L | H | L |
| L | L | H |
| H | X | Z |

logic symbol†

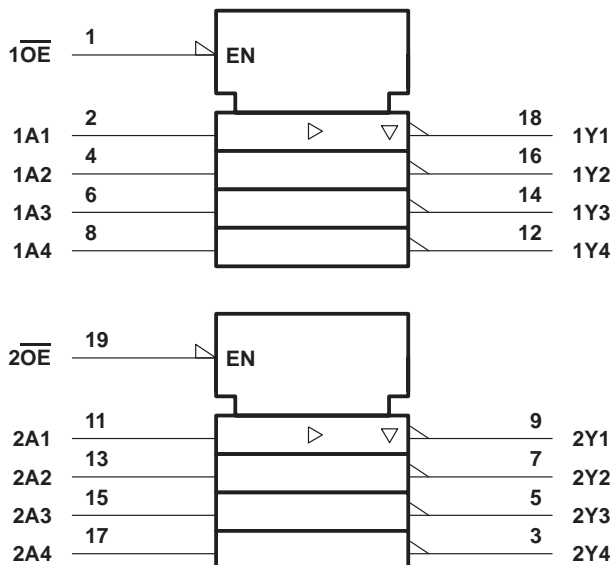

† This symbol is in accordance with ANSI/IEEE Std 91-1984 and IEC Publication 617-12.



Please be aware that an important notice concerning availability, standard warranty, and use in critical applications of Texas Instruments semiconductor products and disclaimers thereto appears at the end of this data sheet.

PRODUCTION DATA information is current as of publication date. Products conform to specifications per the terms of Texas Instruments standard warranty. Production processing does not necessarily include testing of all parameters.

**TEXAS
INSTRUMENTS**

POST OFFICE BOX 655303 • DALLAS, TEXAS 75265

Copyright © 1997, Texas Instruments Incorporated

SN74ALS2240

OCTAL BUFFER AND LINE DRIVER/MOS DRIVER WITH 3-STATE OUTPUTS

SDAS268A – DECEMBER 1994 – REVISED NOVEMBER 1997

recommended operating conditions

| | | MIN | NOM | MAX | UNIT |
|----------|--------------------------------|-----|-----|-----|------|
| V_{CC} | Supply voltage | 4.5 | 5 | 5.5 | V |
| V_{IH} | High-level input voltage | 2 | | | V |
| V_{IL} | Low-level input voltage | | | 0.8 | V |
| T_A | Operating free-air temperature | 0 | | 70 | °C |

electrical characteristics over recommended operating free-air temperature range (unless otherwise noted)

| PARAMETER | TEST CONDITIONS | MIN | TYP† | MAX | UNIT |
|-----------|---|-------------------------|------|------|------|
| V_{IK} | $V_{CC} = 4.5\text{ V}$, $I_I = -18\text{ mA}$ | | | -1.2 | V |
| V_{OH} | $V_{CC} = 4.5\text{ V to } 5.5\text{ V}$, $I_{OH} = -0.4\text{ mA}$ | $V_{CC}-2$ | | | V |
| V_{OL} | $V_{CC} = 4.5\text{ V}$ | $I_{OL} = 1\text{ mA}$ | 0.15 | 0.5 | V |
| | | $I_{OL} = 12\text{ mA}$ | 0.35 | 0.8 | |
| I_{OZH} | $V_{CC} = 5.5\text{ V}$, $V_O = 2.7\text{ V}$ | | | 20 | μA |
| I_{OZL} | $V_{CC} = 5.5\text{ V}$, $V_O = 0.4\text{ V}$ | | | -20 | μA |
| I_I | $V_{CC} = 5.5\text{ V}$, $V_I = 7\text{ V}$ | | | 0.1 | mA |
| I_{IH} | $V_{CC} = 5.5\text{ V}$, $V_I = 2.7\text{ V}$ | | | 20 | μA |
| I_{IL} | $V_{CC} = 5.5\text{ V}$, $V_I = 0.4\text{ V}$ | | | -0.1 | mA |
| $I_{O‡}$ | $V_{CC} = 5.5\text{ V}$, $V_O = 2.25\text{ V}$ | -30 | | -112 | mA |
| I_{OH} | $V_{CC} = 4.5\text{ V}$, | | | -15 | mA |
| I_{OL} | $V_{CC} = 4.5\text{ V}$, | | | 15 | mA |
| I_{CC} | $V_{CC} = 5.5\text{ V}$ | Outputs high | 6 | 11 | mA |
| | | Outputs low | 13 | 23 | |
| | | Outputs disabled | 12 | 20 | |

† All typical values are at $V_{CC} = 5\text{ V}$, $T_A = 25^\circ\text{C}$.

‡ The output conditions have been chosen to produce a current that closely approximates one-half of the true short-circuit output current, I_{OS} .

switching characteristics (see Figure 1)

| PARAMETER | FROM (INPUT) | TO (OUTPUT) | $V_{CC} = 4.5\text{ V to } 5.5\text{ V}$, $C_L = 50\text{ pF}$, $R_1 = 500\ \Omega$, $R_2 = 500\ \Omega$, $T_A = \text{MIN to MAX}^\S$ | | UNIT |
|-----------|-----------------|-------------|--|-----|------|
| | | | MIN | MAX | |
| t_{PLH} | A | Y | 2 | 10 | ns |
| t_{PHL} | | | 2 | 10 | |
| t_{PZH} | \overline{OE} | Y | 5 | 17 | ns |
| t_{PZL} | \overline{OE} | Y | 7 | 20 | ns |
| t_{PHZ} | \overline{OE} | Y | 2 | 10 | ns |
| t_{PLZ} | \overline{OE} | Y | 4 | 15 | ns |

§ For conditions shown as MIN or MAX, use the appropriate value specified under recommended operating conditions.

SN74ALS2240 OCTAL BUFFER AND LINE DRIVER/MOS DRIVER WITH 3-STATE OUTPUTS

SDAS268A – DECEMBER 1994 – REVISED NOVEMBER 1997

PARAMETER MEASUREMENT INFORMATION SERIES 54ALS/74ALS AND 54AS/74AS DEVICES

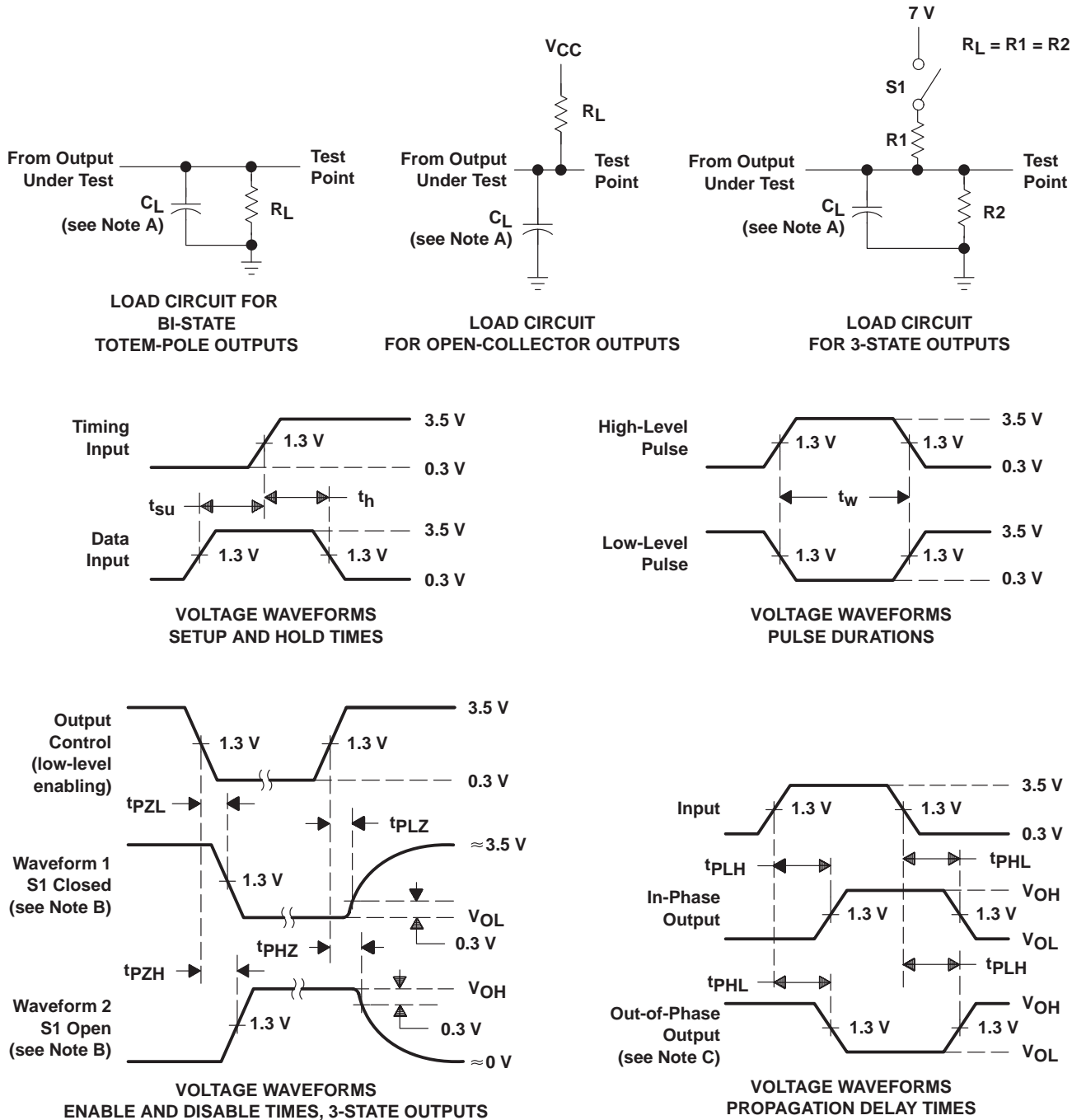

- NOTES:
- A. C_L includes probe and jig capacitance.
 - B. Waveform 1 is for an output with internal conditions such that the output is low except when disabled by the output control. Waveform 2 is for an output with internal conditions such that the output is high except when disabled by the output control.
 - C. When measuring propagation delay items of 3-state outputs, switch S1 is open.
 - D. All input pulses have the following characteristics: $PRR \leq 1$ MHz, $t_r = t_f = 2$ ns, duty cycle = 50%.
 - E. The outputs are measured one at a time with one transition per measurement.

Figure 1. Load Circuits and Voltage Waveforms

IMPORTANT NOTICE

Texas Instruments and its subsidiaries (TI) reserve the right to make changes to their products or to discontinue any product or service without notice, and advise customers to obtain the latest version of relevant information to verify, before placing orders, that information being relied on is current and complete. All products are sold subject to the terms and conditions of sale supplied at the time of order acknowledgement, including those pertaining to warranty, patent infringement, and limitation of liability.

TI warrants performance of its semiconductor products to the specifications applicable at the time of sale in accordance with TI's standard warranty. Testing and other quality control techniques are utilized to the extent TI deems necessary to support this warranty. Specific testing of all parameters of each device is not necessarily performed, except those mandated by government requirements.

CERTAIN APPLICATIONS USING SEMICONDUCTOR PRODUCTS MAY INVOLVE POTENTIAL RISKS OF DEATH, PERSONAL INJURY, OR SEVERE PROPERTY OR ENVIRONMENTAL DAMAGE ("CRITICAL APPLICATIONS"). TI SEMICONDUCTOR PRODUCTS ARE NOT DESIGNED, AUTHORIZED, OR WARRANTED TO BE SUITABLE FOR USE IN LIFE-SUPPORT DEVICES OR SYSTEMS OR OTHER CRITICAL APPLICATIONS. INCLUSION OF TI PRODUCTS IN SUCH APPLICATIONS IS UNDERSTOOD TO BE FULLY AT THE CUSTOMER'S RISK.

In order to minimize risks associated with the customer's applications, adequate design and operating safeguards must be provided by the customer to minimize inherent or procedural hazards.

TI assumes no liability for applications assistance or customer product design. TI does not warrant or represent that any license, either express or implied, is granted under any patent right, copyright, mask work right, or other intellectual property right of TI covering or relating to any combination, machine, or process in which such semiconductor products or services might be or are used. TI's publication of information regarding any third party's products or services does not constitute TI's approval, warranty or endorsement thereof.