

# SN54AS756, SN74AS756, SN74AS757 OCTAL BUFFERS AND LINE DRIVERS WITH OPEN-COLLECTOR OUTPUTS

SDAS040B – DECEMBER 1983 – REVISED JANUARY 1995

- Open-Collector Outputs Drive Bus Lines or Buffer Memory Address Registers
- Eliminate the Need for 3-State Overlap Protection
- pnp Inputs Reduce dc Loading
- Open-Collector Versions of 'AS240A and 'AS241
- Package Options Include Plastic Small-Outline (DW) Packages, Ceramic Chip Carriers (FK), and Standard Plastic (N) and Ceramic (J) 300-mil DIPs

## description

These octal buffers and line drivers are designed specifically to improve the performance and density of 3-state memory address drivers, clock drivers, and bus-oriented receivers and transmitters by eliminating the need for 3-state overlap protection. The designer has a choice of selected combinations of inverting and noninverting outputs, symmetrical active-low output-enable ( $\overline{OE}$ ) inputs, and complementary OE and  $\overline{OE}$  inputs. These devices feature high fan-out and improved fan-in.

The SN54AS756 is characterized for operation over the full military temperature range of  $-55^{\circ}\text{C}$  to  $125^{\circ}\text{C}$ . The SN74AS756 and SN74AS757 are characterized for operation from  $0^{\circ}\text{C}$  to  $70^{\circ}\text{C}$ .

SN54AS756 . . . J PACKAGE  
SN74AS756, SN74AS757 . . . DW OR N PACKAGE  
(TOP VIEW)

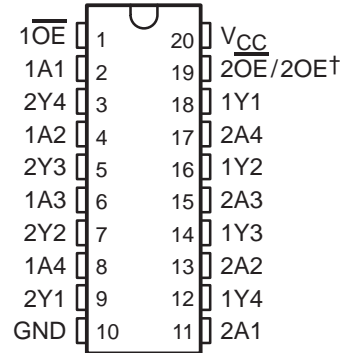

SN54AS756 . . . FK PACKAGE  
(TOP VIEW)

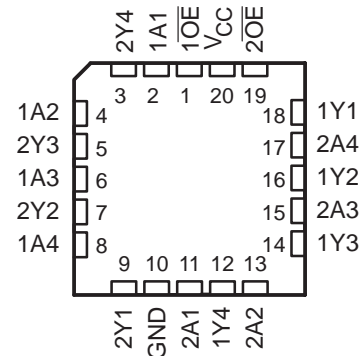

$^{\dagger} 2\overline{OE}$  for 'AS756 or  $2OE$  for SN74AS757

## logic symbols $\ddagger$

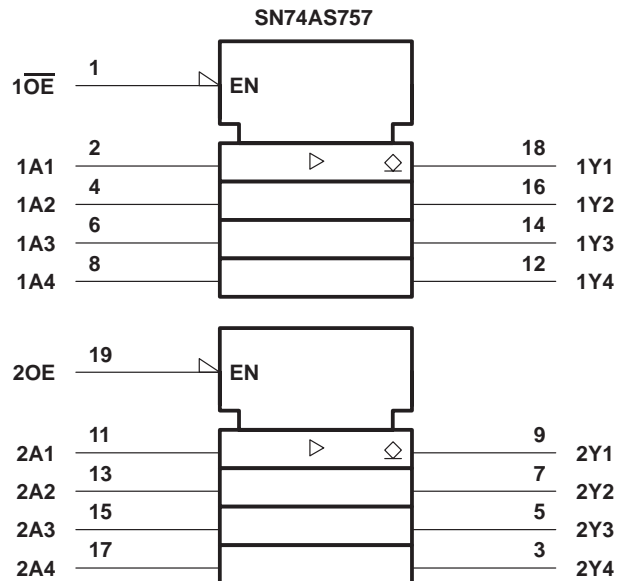
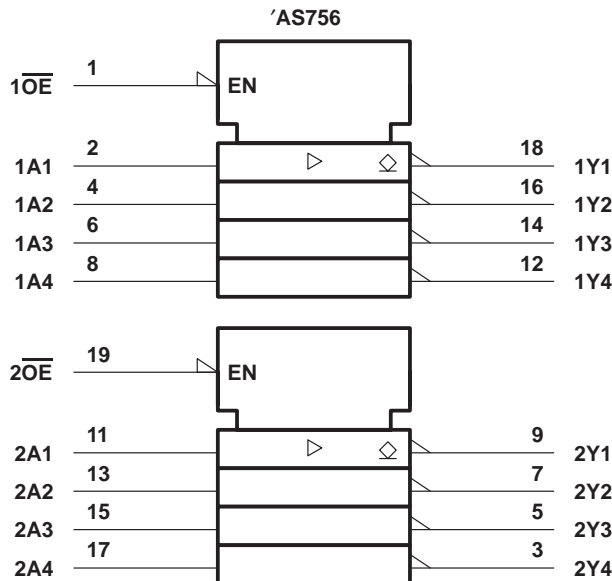

$\ddagger$  These symbols are in accordance with ANSI/IEEE Std 91-1984 and IEC Publication 617-12.

PRODUCTION DATA information is current as of publication date. Products conform to specifications per the terms of Texas Instruments standard warranty. Production processing does not necessarily include testing of all parameters.

TEXAS  
INSTRUMENTS

POST OFFICE BOX 655303 • DALLAS, TEXAS 75265

Copyright © 1995, Texas Instruments Incorporated

# SN54AS756, SN74AS756, SN74AS757 OCTAL BUFFERS AND LINE DRIVERS WITH OPEN-COLLECTOR OUTPUTS

SDAS040B – DECEMBER 1983 – REVISED JANUARY 1995

## logic diagrams (positive logic)

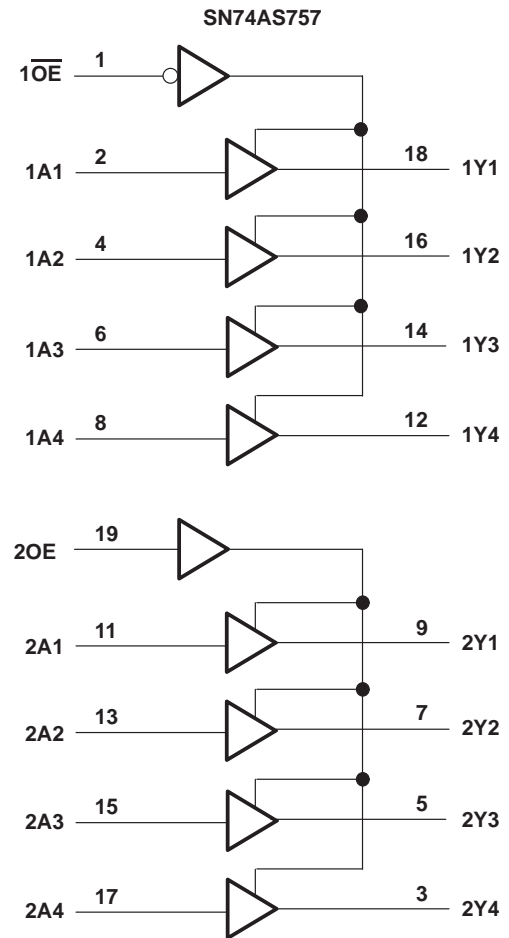
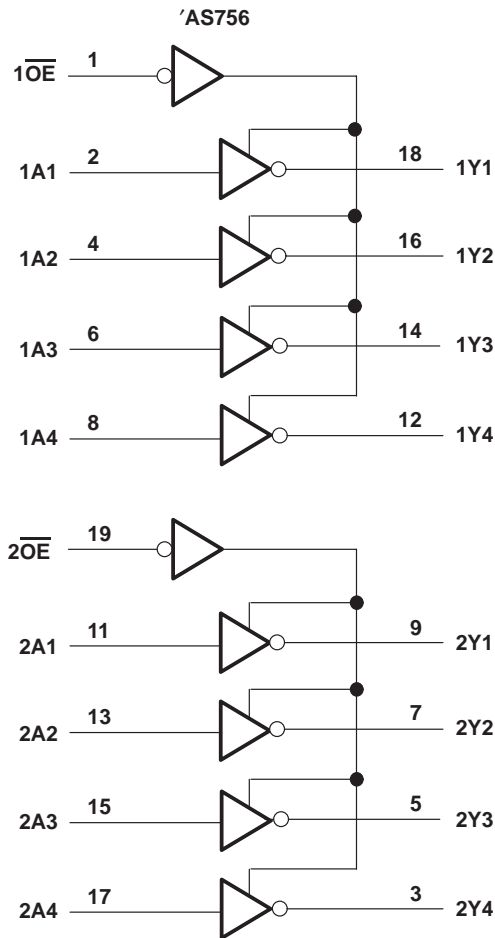

## absolute maximum ratings over operating free-air temperature range (unless otherwise noted)†

Supply voltage, $V_{CC}$	7 V
Input voltage, $V_I$	7 V
Off-state output voltage	7 V
Operating free-air temperature range, $T_A$ : SN54AS756	-55°C to 125°C
SN74AS756, SN74AS757	0°C to 70°C
Storage temperature range	-65°C to 150°C

† Stresses beyond those listed under "absolute maximum ratings" may cause permanent damage to the device. These are stress ratings only, and functional operation of the device at these or any other conditions beyond those indicated under "recommended operating conditions" is not implied. Exposure to absolute-maximum-rated conditions for extended periods may affect device reliability.

**SN54AS756, SN74AS756, SN74AS757**  
**OCTAL BUFFERS AND LINE DRIVERS**  
**WITH OPEN-COLLECTOR OUTPUTS**  
SDAS040B – DECEMBER 1983 – REVISED JANUARY 1995

**recommended operating conditions**

		SN54AS756			SN74AS756 SN74AS757			UNIT
		MIN	NOM	MAX	MIN	NOM	MAX	
$V_{CC}$	Supply voltage	4.5	5	5.5	4.5	5	5.5	V
$V_{IH}$	High-level input voltage	2			2			V
$V_{IL}$	Low-level input voltage			0.7			0.8	V
$V_{OH}$	High-level output voltage			5.5			5.5	V
$I_{OL}$	Low-level output current			48			64	mA
$T_A$	Operating free-air temperature	-55		125	0		70	°C

**electrical characteristics over recommended operating free-air temperature range (unless otherwise noted)**

PARAMETER		TEST CONDITIONS		SN54AS756		SN74AS756 SN74AS757		UNIT
				MIN	TYP†	MAX	MIN	
$V_{IK}$		$V_{CC} = 4.5\text{ V}$ ,	$I_I = -18\text{ mA}$			-1.2	-1.2	V
$I_{OH}$		$V_{CC} = 4.5\text{ V}$ ,	$V_{OH} = 5.5\text{ V}$			0.1	0.1	mA
$V_{OL}$		$V_{CC} = 4.5\text{ V}$	$I_{OL} = 48\text{ mA}$			0.55		V
			$I_{OL} = 64\text{ mA}$				0.55	
$I_I$		$V_{CC} = 5.5\text{ V}$ ,	$V_I = 7\text{ V}$			0.1	0.1	mA
$I_{IH}$		$V_{CC} = 5.5\text{ V}$ ,	$V_I = 2.7\text{ V}$			20	20	μA
$I_{IL}$	A inputs of SN74AS757 only	$V_{CC} = 5.5\text{ V}$ ,	$V_I = 0.4\text{ V}$			-1	-1	mA
	All other inputs					-0.5	-0.5	
$I_{CC}$	'AS756	$V_{CC} = 5.5\text{ V}$	Outputs high	9	15	9	15	mA
			Outputs low	51	80	51	80	
	SN74AS757		Outputs high	21	33	21	33	
			Outputs low	61	95	61	95	

† All typical values are at  $V_{CC} = 5\text{ V}$ ,  $T_A = 25^\circ\text{C}$ .

# SN54AS756, SN74AS756, SN74AS757 OCTAL BUFFERS AND LINE DRIVERS WITH OPEN-COLLECTOR OUTPUTS

SDAS040B – DECEMBER 1983 – REVISED JANUARY 1995

## switching characteristics (see Figure 1)

PARAMETER	FROM (INPUT)	TO (OUTPUT)	V <sub>CC</sub> = 4.5 V to 5.5 V, C <sub>L</sub> = 50 pF, R <sub>L</sub> = 500 Ω, T <sub>A</sub> = MIN to MAX†				UNIT
			SN54AS756		SN74AS756		
			MIN	MAX	MIN	MAX	
t <sub>PLH</sub>	A	Y	3	20	3	19	ns
t <sub>PHL</sub>			1	7	1	6	
t <sub>PLH</sub>	$\overline{OE}$	Y	3	22	3	19.5	ns
t <sub>PHL</sub>			1	8.5	1	7.5	

† For conditions shown as MIN or MAX, use the appropriate value specified under recommended operating conditions.

## switching characteristics (see Figure 1)

PARAMETER	FROM (INPUT)	TO (OUTPUT)	V <sub>CC</sub> = 4.5 V to 5.5 V, C <sub>L</sub> = 50 pF, R <sub>L</sub> = 500 Ω, T <sub>A</sub> = MIN to MAX†		UNIT
			SN74AS757		
			MIN	MAX	
t <sub>PLH</sub>	A	Y	3	18.5	ns
t <sub>PHL</sub>			1	6	
t <sub>PLH</sub>	$\overline{1OE}$	1Y	3	20	ns
t <sub>PHL</sub>			1	7	
t <sub>PLH</sub>	2OE	2Y	3	21	ns
t <sub>PHL</sub>			1	7.5	

† For conditions shown as MIN or MAX, use the appropriate value specified under recommended operating conditions.

PARAMETER MEASUREMENT INFORMATION  
 SERIES 54ALS/74ALS AND 54AS/74AS DEVICES

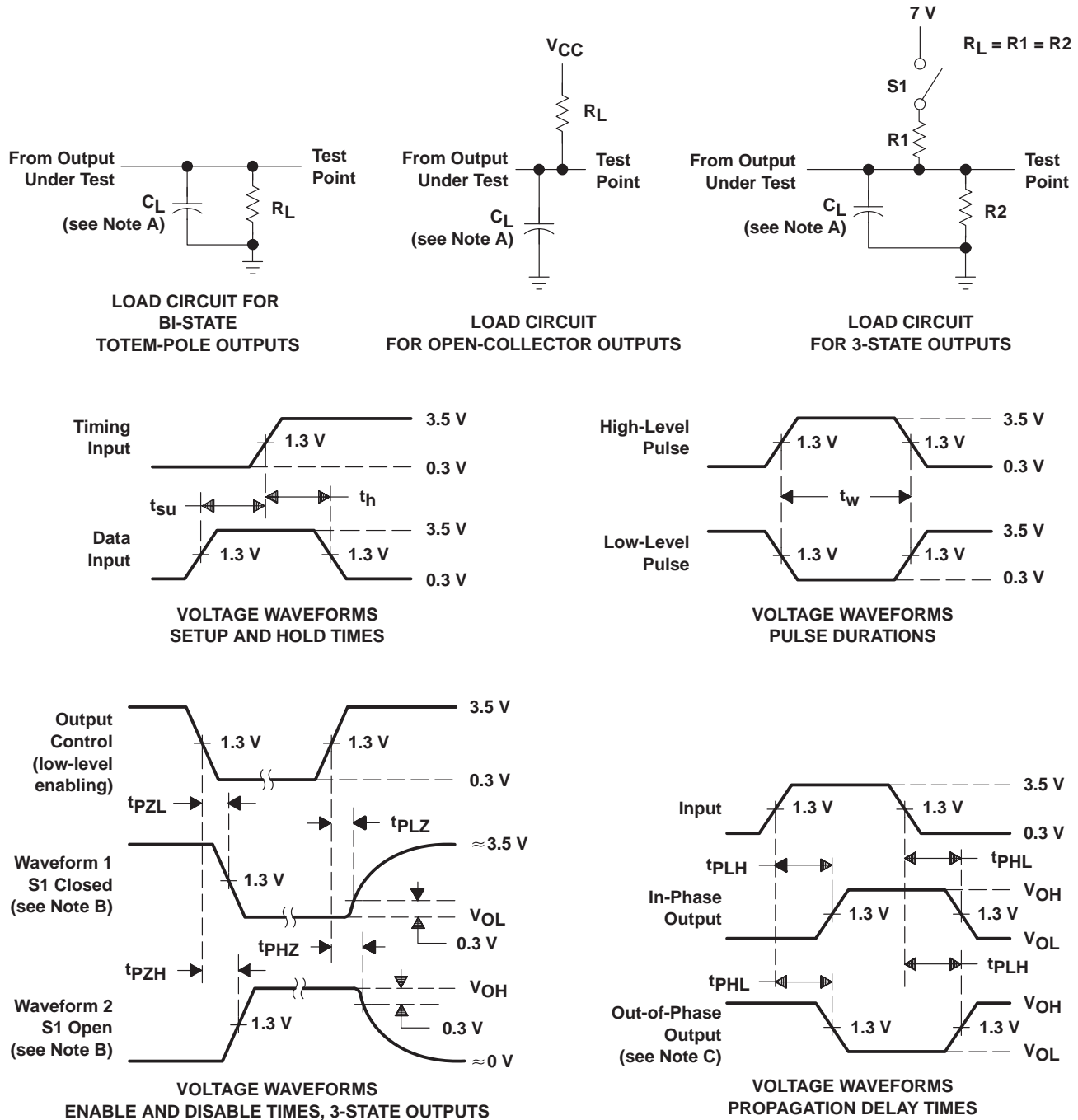

- NOTES: A.  $C_L$  includes probe and jig capacitance.  
 B. Waveform 1 is for an output with internal conditions such that the output is low except when disabled by the output control. Waveform 2 is for an output with internal conditions such that the output is high except when disabled by the output control.  
 C. When measuring propagation delay items of 3-state outputs, switch S1 is open.  
 D. All input pulses have the following characteristics:  $PRR \leq 1$  MHz,  $t_r = t_f = 2$  ns, duty cycle = 50%.  
 E. The outputs are measured one at a time with one transition per measurement.

Figure 1. Load Circuits and Voltage Waveforms

## IMPORTANT NOTICE

Texas Instruments and its subsidiaries (TI) reserve the right to make changes to their products or to discontinue any product or service without notice, and advise customers to obtain the latest version of relevant information to verify, before placing orders, that information being relied on is current and complete. All products are sold subject to the terms and conditions of sale supplied at the time of order acknowledgement, including those pertaining to warranty, patent infringement, and limitation of liability.

TI warrants performance of its semiconductor products to the specifications applicable at the time of sale in accordance with TI's standard warranty. Testing and other quality control techniques are utilized to the extent TI deems necessary to support this warranty. Specific testing of all parameters of each device is not necessarily performed, except those mandated by government requirements.

CERTAIN APPLICATIONS USING SEMICONDUCTOR PRODUCTS MAY INVOLVE POTENTIAL RISKS OF DEATH, PERSONAL INJURY, OR SEVERE PROPERTY OR ENVIRONMENTAL DAMAGE ("CRITICAL APPLICATIONS"). TI SEMICONDUCTOR PRODUCTS ARE NOT DESIGNED, AUTHORIZED, OR WARRANTED TO BE SUITABLE FOR USE IN LIFE-SUPPORT DEVICES OR SYSTEMS OR OTHER CRITICAL APPLICATIONS. INCLUSION OF TI PRODUCTS IN SUCH APPLICATIONS IS UNDERSTOOD TO BE FULLY AT THE CUSTOMER'S RISK.

In order to minimize risks associated with the customer's applications, adequate design and operating safeguards must be provided by the customer to minimize inherent or procedural hazards.

TI assumes no liability for applications assistance or customer product design. TI does not warrant or represent that any license, either express or implied, is granted under any patent right, copyright, mask work right, or other intellectual property right of TI covering or relating to any combination, machine, or process in which such semiconductor products or services might be or are used. TI's publication of information regarding any third party's products or services does not constitute TI's approval, warranty or endorsement thereof.