

SN54BCT29841, SN74BCT29841 10-BIT BUS-INTERFACE D-TYPE LATCHES WITH 3-STATE OUTPUTS

SCBS024C – MARCH 1989 – REVISED NOVEMBER 1993

- State-of-the-Art BiCMOS Design Significantly Reduces I_{CCZ}
- ESD Protection Exceeds 2000 V Per MIL-STD-883C, Method 3015; Exceeds 200 V Using Machine Model (C = 200 pF, R = 0)
- Power-Up High-Impedance State
- Provides Extra Bus-Driving Latches Necessary For Wider Address/Data Paths or Buses With Parity
- Package Options Include Plastic Small-Outline (DW) Packages, Ceramic Chip Carriers (FK) and Flatpacks (W), and Standard Plastic and Ceramic 300-mil DIPs (JT, NT)

SN54BCT29841 . . . JT OR W PACKAGE
SN74BCT29841 . . . DW OR NT PACKAGE
(TOP VIEW)

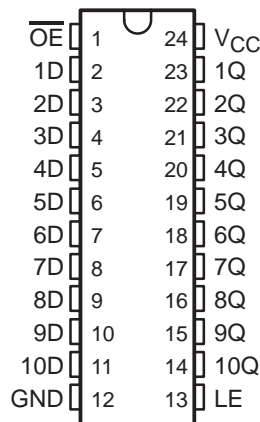

description

These 10-bit bus-interface latches feature 3-state outputs designed specifically for driving highly capacitive or relatively low-impedance loads. They are particularly suitable for implementing wider buffer registers, I/O ports, bidirectional bus drivers with parity, and working registers.

The ten latches of the 'BCT29841 are transparent D-type latches. When the latch-enable (LE) input is high, the Q outputs will follow the data (D) inputs. When LE is taken low, the Q outputs are latched at the levels that were set up at the D inputs.

A buffered output-enable (\overline{OE}) input can be used to place the nine outputs in either a normal logic state (high or low level) or a high-impedance state. In the high-impedance state, the outputs neither load nor drive the bus lines significantly. The high-impedance state and increased drive provide the capability to drive bus lines without need for interface or pullup components.

The output enable (\overline{OE}) does not affect the internal operation of the latches. Old data can be retained or new data can be entered while the outputs are in the high-impedance state.

The SN54BCT29841 is characterized for operation over the full military temperature range of -55°C to 125°C . The SN74BCT29841 is characterized for operation from 0°C to 70°C .

SN54BCT29841 . . . FK PACKAGE
(TOP VIEW)

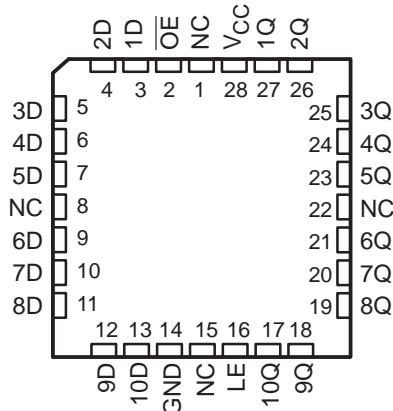

NC – No internal connection

FUNCTION TABLE

INPUTS			OUTPUT
\overline{OE}	LE	D	Q
L	H	H	H
L	H	L	L
L	L	X	Q_0
H	X	X	Z

SN54BCT29841, SN74BCT29841 10-BIT BUS-INTERFACE D-TYPE LATCHES WITH 3-STATE OUTPUTS

SCBS024C – MARCH 1989 – REVISED NOVEMBER 1993

logic symbol†

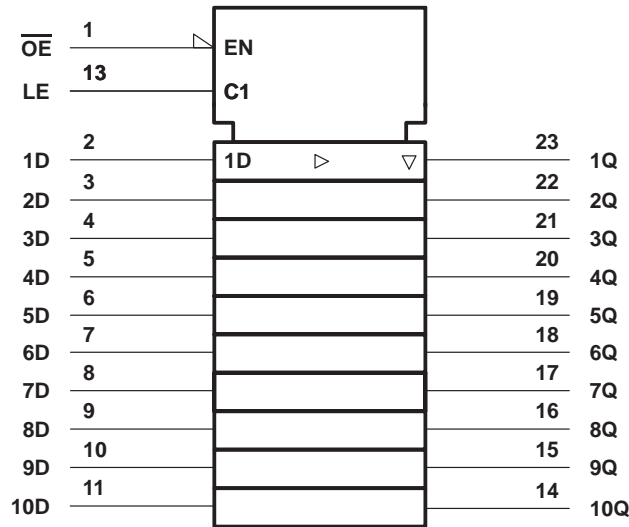

† This symbol is in accordance with ANSI/IEEE Std 91-1984 and IEC Publication 617-12.

logic diagram (positive logic)

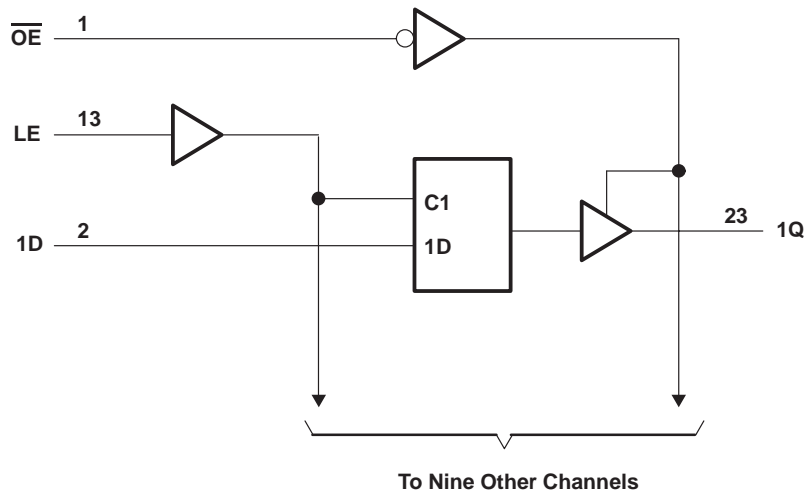

Pin numbers shown are for the DW, JT, NT, and W packages.

SN54BCT29841, SN74BCT29841
10-BIT BUS-INTERFACE D-TYPE LATCHES
WITH 3-STATE OUTPUTS

SCBS024C – MARCH 1989 – REVISED NOVEMBER 1993

absolute maximum ratings over operating free-air temperature range (unless otherwise noted)†

Supply voltage range, V_{CC}	– 0.5 V to 7 V
Input voltage range, V_I (see Note 1)	– 0.5 V to 7 V
Voltage range applied to any output in the disabled or power-off state, V_O	– 0.5 V to 7 V
Voltage range applied to any output in the high state, V_O	– 0.5 V to V_{CC}
Input clamp current, I_{IK} ($V_I < 0$)	– 30 mA
Current into any output in the low state, I_O : SN54BCT29841	48 mA
SN74BCT29841	96 mA
Operating free-air temperature range: SN54BCT29841	– 55°C to 125°C
SN74BCT29841	0°C to 70°C
Storage temperature range	– 65°C to 150°C

† Stresses beyond those listed under “absolute maximum ratings” may cause permanent damage to the device. This is a stress rating only, and functional operation of the device at these or any other conditions beyond those indicated in the “recommended operating conditions” section of this specification is not implied. Exposure to absolute-maximum-rated conditions for extended periods may affect device reliability.

NOTE 1: The input and output negative-voltage ratings may be exceeded if the input and output clamp-current ratings are observed.

recommended operating conditions

		SN54BCT29841			SN74BCT29841			UNIT
		MIN	NOM	MAX	MIN	NOM	MAX	
V_{CC}	Supply voltage	4.5	5	5.5	4.5	5	5.5	V
V_{IH}	High-level input voltage	2			2			V
V_{IL}	Low-level input voltage			0.8			0.8	V
I_{IK}	Input clamp current			–18			–18	mA
I_{OH}	High-level output current			–15			–24	mA
I_{OL}	Low-level output current			24			48	mA
T_A	Operating free-air temperature	–55		125	0		70	°C



SN54BCT29841, SN74BCT29841 10-BIT BUS-INTERFACE D-TYPE LATCHES WITH 3-STATE OUTPUTS

SCBS024C – MARCH 1989 – REVISED NOVEMBER 1993

electrical characteristics over recommended operating free-air temperature range (unless otherwise noted)

PARAMETER	TEST CONDITIONS		SN54BCT29841		SN74BCT29841		UNIT		
			MIN	TYP†	MAX	MIN		TYP†	MAX
V_{IK}	$V_{CC} = 4.5\text{ V}$,	$I_I = -18\text{ mA}$			-1.2		-1.2	V	
V_{OH}	$V_{CC} = 4.5\text{ V}$	$I_{OH} = -15\text{ mA}$	2.4		2.4			V	
		$I_{OH} = -24\text{ mA}$			2				
V_{OL}	$V_{CC} = 4.5\text{ V}$	$I_{OL} = 24\text{ mA}$	0.35	0.55				V	
		$I_{OL} = 48\text{ mA}$				0.42	0.55		
I_I	$V_{CC} = 5.5\text{ V}$,	$V_I = 7\text{ V}$			0.1		0.1	mA	
I_{IH}	$V_{CC} = 5.5\text{ V}$,	$V_I = 2.7\text{ V}$	-10	-75	-10	-75		μA	
I_{IL}	$V_{CC} = 5.5\text{ V}$,	$V_I = 0.5\text{ V}$			-0.2		-0.2	mA	
I_{OS}^\ddagger	$V_{CC} = 5.5\text{ V}$,	$V_O = 0$	-75	-275	-75	-275		mA	
I_{OZH}	$V_{CC} = 5.5\text{ V}$,	$V_O = 2.7\text{ V}$			20		20	μA	
I_{OZL}	$V_{CC} = 5.5\text{ V}$,	$V_O = 0.5\text{ V}$			-20		-20	μA	
I_{CCL}	$V_{CC} = 5.5\text{ V}$,	Outputs open			3	7	3	7	mA
I_{CCH}	$V_{CC} = 5.5\text{ V}$,	Outputs open			24	35	24	35	mA
I_{CCZ}	$V_{CC} = 5.5\text{ V}$,	Outputs open			3	7	3	7	mA
C_i	$V_{CC} = 5\text{ V}$,	$V_I = 2.5\text{ V}$ or 0.5 V			5.5		5.5		pF
C_o	$V_{CC} = 5\text{ V}$,	$V_O = 2.5\text{ V}$ or 0.5 V			8		8		pF

† All typical values are at $V_{CC} = 5\text{ V}$, $T_A = 25^\circ\text{C}$.

‡ Not more than one output should be tested at a time, and the duration of the test should not exceed one second.

timing requirements over recommended ranges of supply voltage and operating free-air temperature (unless otherwise noted)

		$V_{CC} = 5\text{ V}$, $T_A = 25^\circ\text{C}$		SN54BCT29841		SN74BCT29841		UNIT
		MIN	MAX	MIN	MAX	MIN	MAX	
t_w	Pulse duration, LE high or low	4		4		4		ns
t_{su}	Setup time, data before LE↓	2		2		2		ns
t_h	Hold time, data after LE↓	High	1.5	1.5		1.5		ns
		Low	3.5	3.5		3.5		

switching characteristics over recommended ranges of supply voltage and operating free-air temperature, $C_L = 50\text{ pF}$ (unless otherwise noted) (see Note 2)

PARAMETER	FROM (INPUT)	TO (OUTPUT)	$V_{CC} = 5\text{ V}$, $T_A = 25^\circ\text{C}$			SN54BCT29841		SN74BCT29841		UNIT
			MIN	TYP	MAX	MIN	MAX	MIN	MAX	
t_{PLH}	D	Q	1.8	4.7	6.7	1.8	8.1	1.8	7.5	ns
t_{PHL}			2	5	7.3	2	9.1	2	8.6	
t_{PLH}	LE	Q	2.5	5.4	7.6	2.5	9.3	2.5	8.6	ns
t_{PHL}			2.7	5.4	7.5	2.7	8.7	2.7	8.1	
t_{PZH}	\overline{OE}	Q	1.8	5.3	7.4	1.8	9.2	1.8	9.2	ns
t_{PZL}			4.4	8.1	10.6	4.4	13.4	4.4	12.8	
t_{PHZ}	\overline{OE}	Q	2.6	4.9	6.9	2.6	7.7	2.6	6.9	ns
t_{PLZ}			1.6	4.4	6.3	1.6	7.7	1.6	6.9	

NOTE 2: Load circuits and voltage waveforms are shown in Section 1.



IMPORTANT NOTICE

Texas Instruments and its subsidiaries (TI) reserve the right to make changes to their products or to discontinue any product or service without notice, and advise customers to obtain the latest version of relevant information to verify, before placing orders, that information being relied on is current and complete. All products are sold subject to the terms and conditions of sale supplied at the time of order acknowledgement, including those pertaining to warranty, patent infringement, and limitation of liability.

TI warrants performance of its semiconductor products to the specifications applicable at the time of sale in accordance with TI's standard warranty. Testing and other quality control techniques are utilized to the extent TI deems necessary to support this warranty. Specific testing of all parameters of each device is not necessarily performed, except those mandated by government requirements.

CERTAIN APPLICATIONS USING SEMICONDUCTOR PRODUCTS MAY INVOLVE POTENTIAL RISKS OF DEATH, PERSONAL INJURY, OR SEVERE PROPERTY OR ENVIRONMENTAL DAMAGE ("CRITICAL APPLICATIONS"). TI SEMICONDUCTOR PRODUCTS ARE NOT DESIGNED, AUTHORIZED, OR WARRANTED TO BE SUITABLE FOR USE IN LIFE-SUPPORT DEVICES OR SYSTEMS OR OTHER CRITICAL APPLICATIONS. INCLUSION OF TI PRODUCTS IN SUCH APPLICATIONS IS UNDERSTOOD TO BE FULLY AT THE CUSTOMER'S RISK.

In order to minimize risks associated with the customer's applications, adequate design and operating safeguards must be provided by the customer to minimize inherent or procedural hazards.

TI assumes no liability for applications assistance or customer product design. TI does not warrant or represent that any license, either express or implied, is granted under any patent right, copyright, mask work right, or other intellectual property right of TI covering or relating to any combination, machine, or process in which such semiconductor products or services might be or are used. TI's publication of information regarding any third party's products or services does not constitute TI's approval, warranty or endorsement thereof.