



---

---

===== CONTENTS =====

1. INTRODUCTION ..... 3

2. FEATURES..... 3

3. PIN ASSIGNMENT ..... 4

4. ROM TABLE..... 6

5. RAM TABLE ..... 7

6. SYSTEM CLOCK ..... 8

6.1 CRYSTAL INPUT ..... 8

6.2 ROSC INPUT ..... 8

7. I/O PORT ..... 9

8. TIMER/COUNTER ..... 10

9. PUSH-PULL DAC..... 11

10. REGULATOR ..... 11

11. ABSOLUTE MAXIMUM RATINGS..... 12

12. ELECTRICAL CHARACTERISTICS..... 12

13. APPLICATION CIRCUIT ..... 13

14. BONDING PAD..... 15



**History**

<b>Version</b>	<b>Release Date</b>	<b>Descript</b>
<b>1.0</b>	<b>06/31/2006</b>	<b>1. First release.</b>
<b>1.1</b>	<b>01/22/2007</b>	<b>1. Remove Current DAC Function.</b>
<b>1.2</b>	<b>02/12/2007</b>	<b>1. Add Pin Location 2. Add Bonding Pad Map</b>
<b>1.3</b>	<b>02/27/2007</b>	<b>1. Add Application Circuit</b>
<b>1.4</b>	<b>03/01/2007</b>	<b>1. Add ROSC Application Circuit.</b>
<b>1.6</b>	<b>03/07/2007</b>	<b>1. Modify application circuit error. 2. Add Regulator section.</b>



## 1. INTRODUCTION

The SNC759 is a simply chip base on new DSP technology. SNC759 provide simply and easy control functions for system manufactory. SNC759 also is a high performance voice IC. That is built-in 64K word high speed ROM, and by different model to built-in 64K word ~ 960K words low speed ROM, the maximum program size is full ROM size include high-speed and low-speed ROM.

The SNC759 have three timer, one real time clock and one watchdog timer and built-in a hi-performance software synthesizer to provide lot of voice effects, such as hi-decompression engine to support from 1.5Kbps ~ 32Kbps compression rate for speech and music, multi-channel voice synthesizer to provide 12-channel wave table melody.

## 2. FEATURES

- ◆ Power supply: 2.4V ~ 3.6V (for 2 batteries application)  
3.6V ~ 5.1V (for 3 batteries application)
- ◆ Built-in a new 16-bit DSP core with 16 MIPS CPU performance
- ◆ Software-based voice/melody processing
- ◆ Rich Function Instruction Set
- ◆ System Clock
  - 16MHz crystal or R-C type oscillator for system clock
- ◆ I/O Ports:
  - 24 I/O pins (P0.0~P0.15, P1.0~P1.7)
  - P0.15 with IR carrier signal
- ◆ RAM size: 4K\*16 bits
- ◆ ROM size: 1024KW
  - High performance program ROM: 64K\*16 bits
  - Low speed ROM: 960KW
- ◆ Maximum program size: Full ROM Size
- ◆ 3 Timer, 1 RTC, 1 WDT
  - Timer With Individual pre-scalar and auto-reload function
  - RTC with 0.25/0.5/1 sec period
  - Watchdog Timer
- ◆ 9 Interrupt Sources
  - 4 for Internal Timer (timer0, 1, 2 and RTC)
  - 4 for External (P0.0~P0.3)
  - 1 for DA (Push Pull DAC)
- ◆ Two voice channels / 12 melody channels
- ◆ Three 8-bit timer with auto-reload function
- ◆ Built in a 12-bit Push-Pull DAC output
- ◆ Internal regulator provided



- ◆ Low Voltage Reset
- ◆ Low Voltage Detect
- ◆ Sampling Rate: 8KHz ~16KHz
- ◆ Built-in software voice synthesizer (multiple bit-rate solution 1.5Kbps, 1.72Kbps, 2Kbps, 2.4Kbps, 3Kbps, 4Kbps, 5Kbps, 6Kbps, 8Kbps, 16Kbps, 20Kbps, 24Kbps, 28Kbps, 32Kbps, 35Kbps @ 8K, 10K, 12K, 14K, 16K sampling rate)
- ◆ Built-in software melody synthesizer includes the dual-tone melody and 12-channel wave-table melody.

### 3. PIN ASSIGNMENT

Pin No.	Symbol	I/O	Descriptions
1	Test	I	Test Pin for testing using
2	VSSIO2	I	Negative power supply
3	CVSS	I	Negative power supply for core circuit
4	RST	I	Chip reset
5	CKSEL	I	Crystal/RC-type oscillator select for high speed clock
6	VDDIO2	I	Positive power supply
7	CVDD	I	Positive power supply for core circuit
8	REGOUT	O	Regulator voltage output
9	VSSA	I	Negative power supply
10	XIN	I	High speed clock crystal input
11	XOUT	O	High speed clock crystal output
12	LXIN	I	Low speed clock crystal input
13	LXOUT	O	Low speed clock crystal output
14	VDDA	I	Positive power supply
15	P0.0	I/O	I/O Port 0
16	P0.1	I/O	I/O Port 0
17	P0.2	I/O	I/O Port 0
18	P0.3	I/O	I/O Port 0
19	VSSIO0	I	Negative power supply
20	P0.4	I/O	I/O Port 0
21	P0.5	I/O	I/O Port 0
22	P0.6	I/O	I/O Port 0
23	P0.7	I/O	I/O Port 0
24	VDDIO0	I	Positive power supply
25	P0.8	I/O	I/O Port 0
26	P0.9	I/O	I/O Port 0
27	P0.10	I/O	I/O Port 0
28	P0.11	I/O	I/O Port 0
29	VSSIO0	I	Negative power supply



Pin No.	Symbol	I/O	Descriptions
30	P0.12	I/O	I/O Port 0
31	P0.13	I/O	I/O Port 0
32	P0.14	I/O	I/O Port 0
33	P0.15	I/O	I/O Port 0
34	P1.0	I/O	I/O Port 1
35	P1.1	I/O	I/O Port 1
36	P1.2	I/O	I/O Port 1
37	P1.3	I/O	I/O Port 1
38	VDDIO1	I	Positive power supply
39	P1.4	I/O	I/O Port 1
40	P1.5	I/O	I/O Port 1
41	P1.6	I/O	I/O Port 1
42	P1.7	I/O	I/O Port 1
43	VSSIO1	I	Negative power supply
44	VSSPP	I	Negative power supply
45	BP0	O	Push Pull output 1
46	VDDPP	I	Positive power supply
47	BN0	O	Push Pull output 2
48	VSSPP	I	Negative power supply

## 4. ROM TABLE

The total ROM size is 1024K words. It split two parts including high speed and low speed ROM area, but user also can program all area. In high speed ROM had a small OS to control all function flow. We recommend user put you program in high speed ROM and put data in low speed ROM to get high performance.

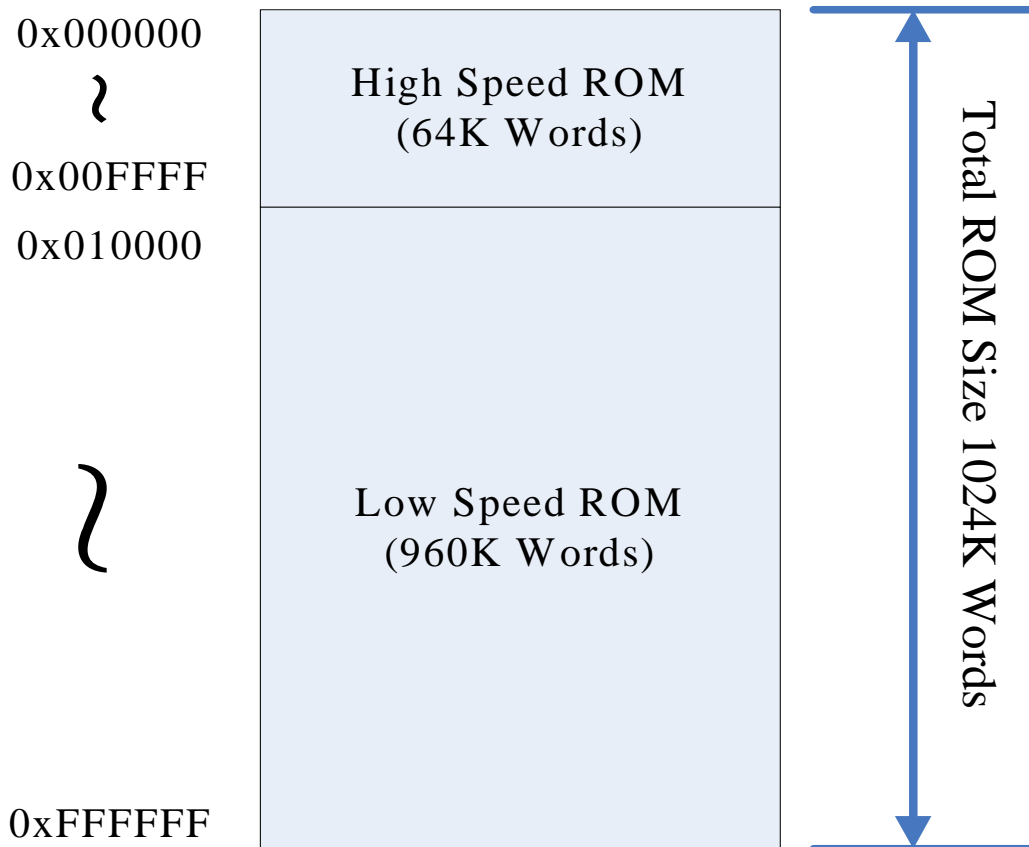

## 5. RAM TABLE

Total RAM size is 4K words, and each one bank is 256 words. The RAM size 0~3K words is for algorithm using and last 1K words is for user using.

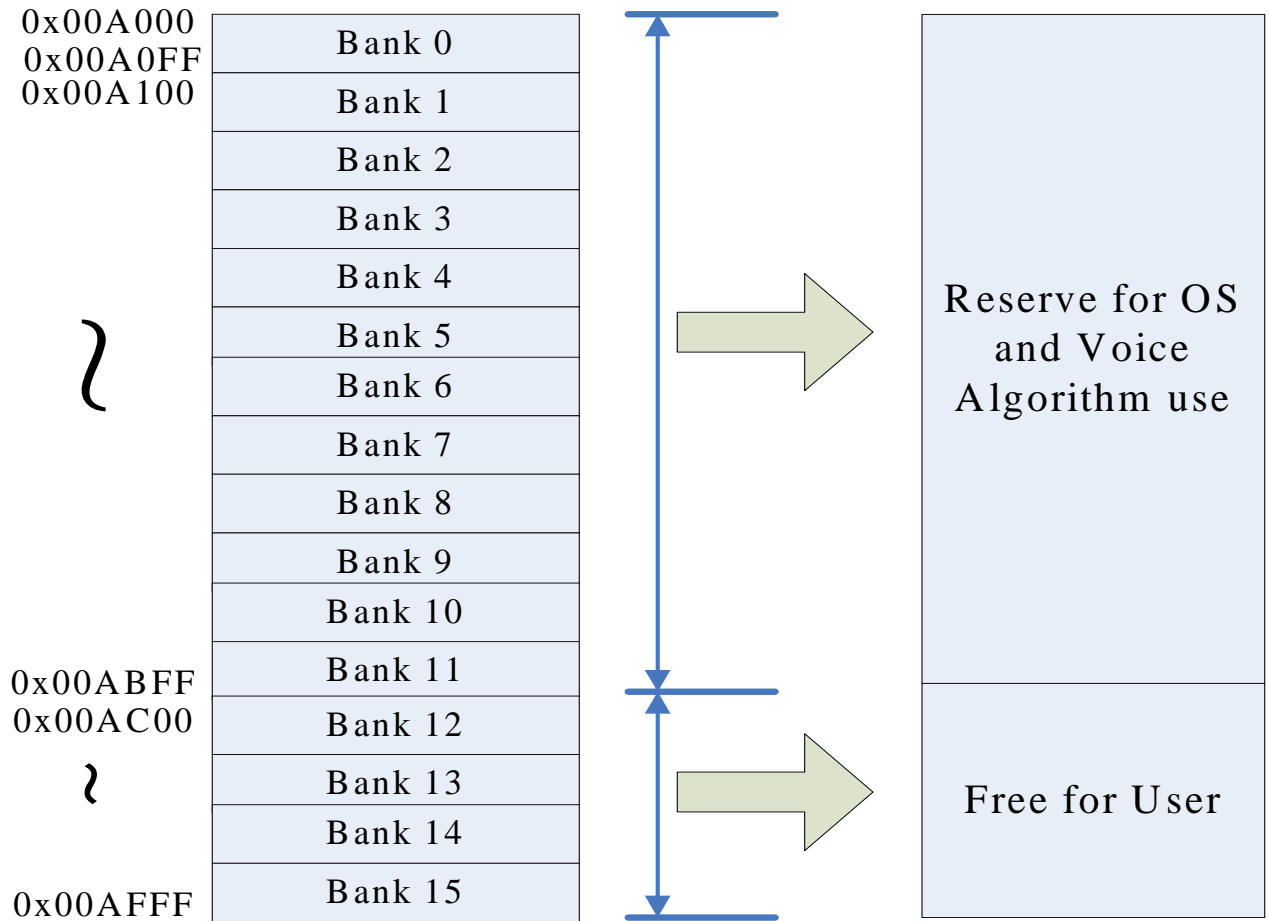

## 6. System Clock

The system clock had dual source high clock and low clock input, user can selected from 16Mhz crystal or ROOSC for high clock and 32768 crystal for low clock. In Normal mode, user can select high clock source from 16Mhz crystal or ROOSC, In Slow mode, user must select 32768 crystal to input system clock.

### 6.1 Crystal Input

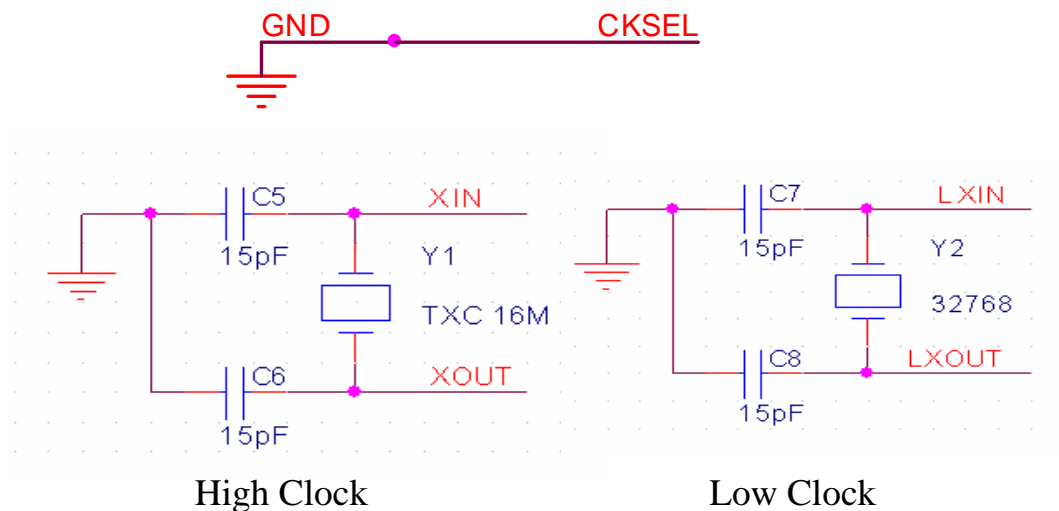

### 6.2 ROOSC Input

User uses ROOSC mode to make High clock. The internal clock is reference clock from 32768 X'tal to fine tune to 16MHz. So, when ROOSC mode is select, the 32768 X'tal must provide reference clock to system.

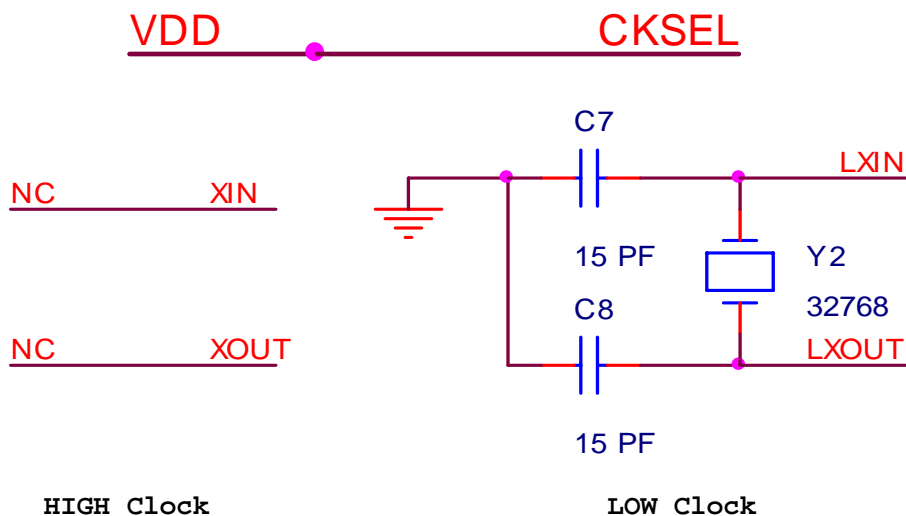



## 7. I/O PORT

SNC759 provides one a 24-bit I/O port for user application (P0.0~P0.15, P1.0~P1.7). The input pull high resistor of each pin can be programmed by Port Pull-High register. The direction of I/O port is selected by Port Direction register.

The Port0 (P0.0~P0.15) and Port1 (P1.0~P1.7) can wake the chip up from the stop mode and watch mode. P0.15 can be modulated with a 38.5Khz carry signal to realize IR signal transmission.

When user uses GPIO to wake up chip, the GPIO must setting to input mode and Pull-High all I/O pin.

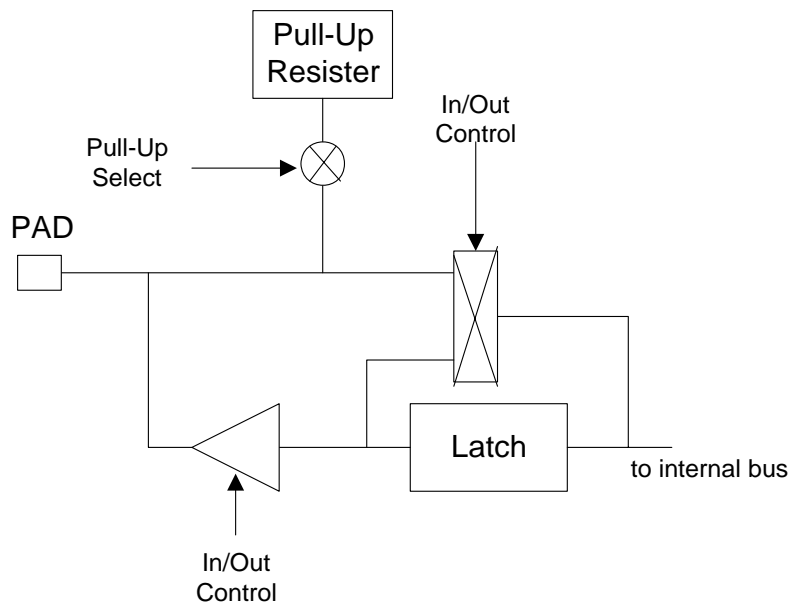

**I/O Configuration of P0.0~P0.15**

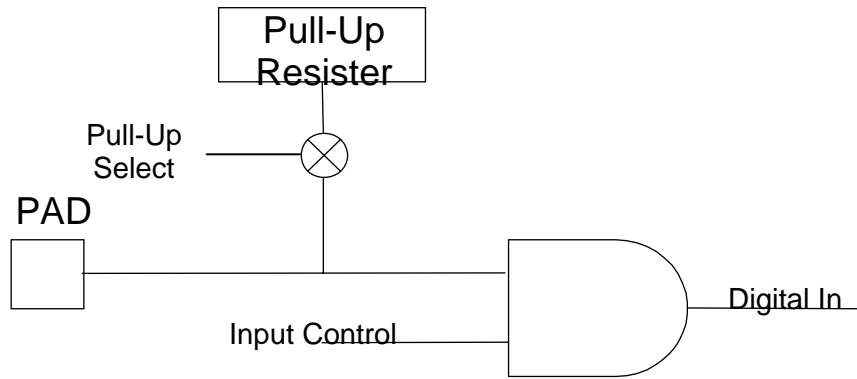

**Input Port Configuration of Port 1 (P1.0~P1.7)**

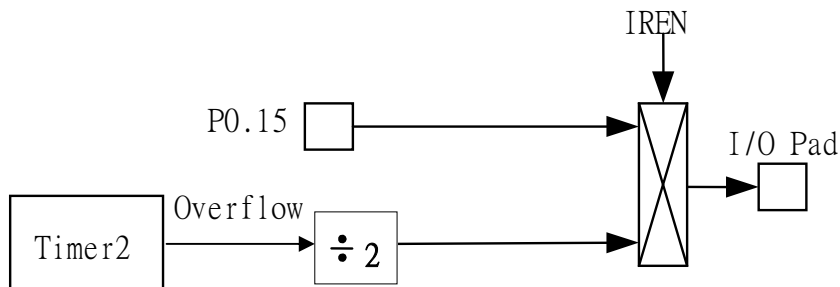

**P0.15 Modulated with a carry signal**

## 8. TIMER/COUNTER

SNC759 provides three 8-bit timer/event counters (T0/T1/T2). Each timer is 8-bit binary up-count timer with pre-scalar and auto-reload function. Timer 0 (T0) is used when voice playing, so user should avoid to use T0.

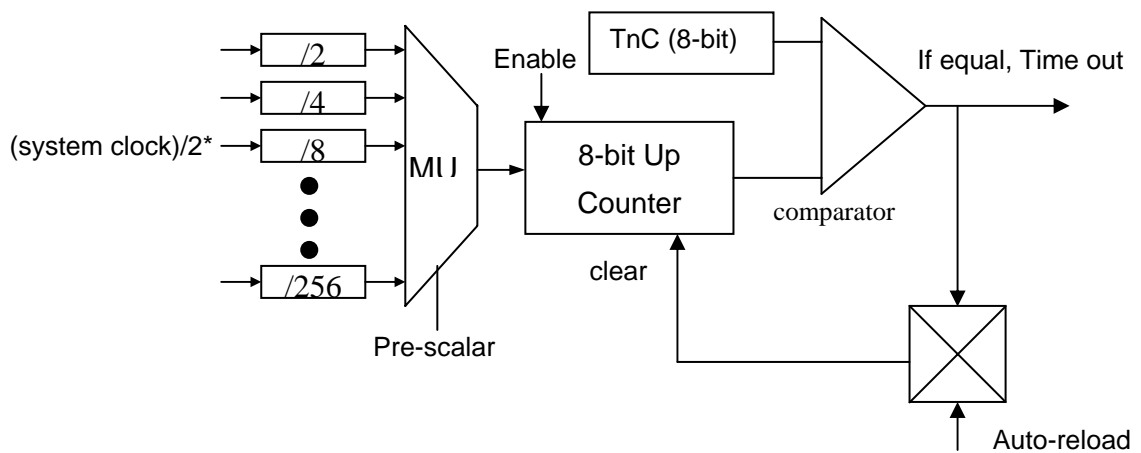

## 9. Push-Pull DAC

To play out voices, SNC759 contains Push-Pull DAC (direct drive) for the users' applications.

## 10. Regulator

The SNC759 provide a linear regulator for core power (CVDD). The accuracy output voltage is  $2.8V \pm 0.2V$  and it can be power-downed by software.

### Features:

**Input supply voltage: 3.6V ~ 5.1V**

**Dropout voltage of 0.8V at 20mA output current:**

**Output current: 20mA**

**Power down current: <1uA**

**Accuracy output voltage: 2.6~2.8V**

Application circuit:

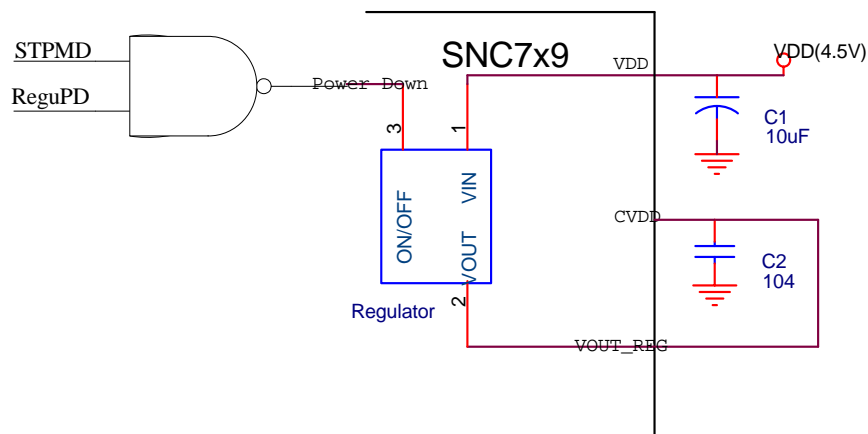

## 11. ABSOLUTE MAXIMUM RATINGS

Items	Symbol	Min	Max	Unit.
Supply Voltage	$V_{DD-V}$	-0.3	6.0	V
Input Voltage	$V_{IN}$	GND-0.3	$V_{DD}+0.3$	V
Operating Temperature	$T_{OP}$	0	55	°C
Storage Temperature	$T_{STG}$	-55.0	125.0	°C

## 12. ELECTRICAL CHARACTERISTICS

Item	Sym.	Min.	Typ.	Max.	Unit	Condition
Operating Voltage	$V_{DD}$	2.4	-	3.6	V	
	$V_{DD}$	3.6	-	5.1	V	
Standby current	$I_{SBY}$	-	2.0	-	$\mu A$	$V_{DD}=3V$ , no load
Operating Current	$I_{OPR}$	-	10	-	mA	$V_{DD}=3V$ , no load
Watch mode Current	$I_{WCH}$	-	12	-	$\mu A$	$V_{DD}=3V$ , 9instructions
Slow mode Current	$I_{SL}$	-	50	-	$\mu A$	$V_{DD}=3.3V$ , no load
Pull-Up resistor of P0, P1	$R_{PU}$	-	800	-	$K\Omega$	$V_{DD}=3V$ , no load
Input current of P0, P1	$I_{IH}$	-	-	10.0	$\mu A$	$V_{DD}=3V, V_{IN}=3V$
Drive current of P0, P1	$I_{OD}$	-	4	-	mA	$V_{DD}=3V, V_O=2.4V$
Sink Current of P0, P1	$I_{OS}$	-	6	-	mA	$V_{DD}=3V, V_O=0.4V$
Drive current of Buo1	$I_{OD}$		150	-	mA	$V_{DD}=3V, Buo1=1.5V$
Sink Current of Buo1	$I_{OS}$		150	-	mA	$V_{DD}=3V, Buo1=1.5V$
Drive Current of Buo2	$I_{OD}$		150	-	mA	$V_{DD}=3V, Buo2=1.5V$
Sink Current of Buo2	$I_{OS}$		150	-	mA	$V_{DD}=3V, Buo2=1.5V$
Oscillation Freq. (crystal)	$F_{OSC}$	-	16.0	-	MHz	$V_{DD}=3V$

## 13. Application Circuit

### X'TAL

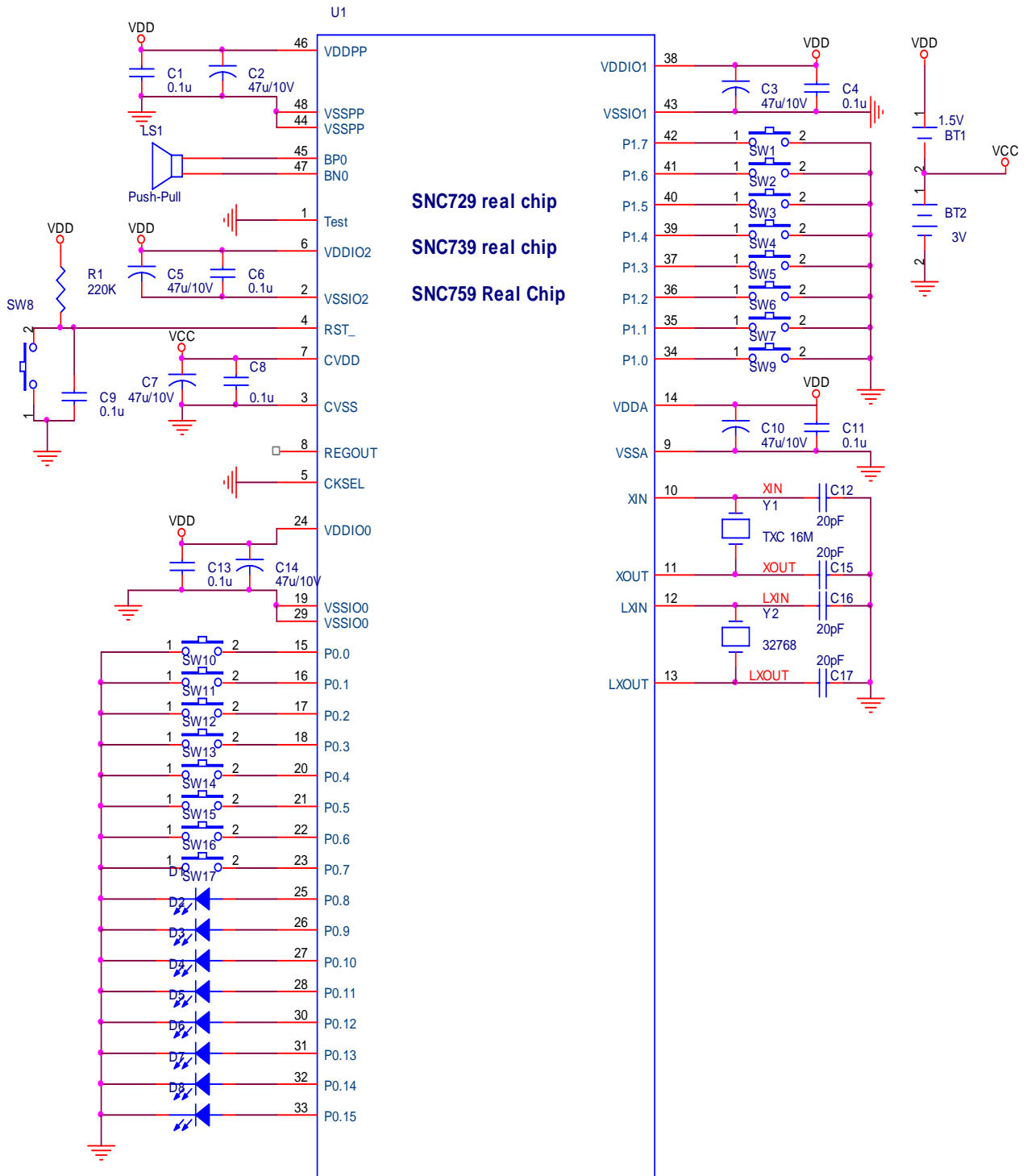

**ROSC**

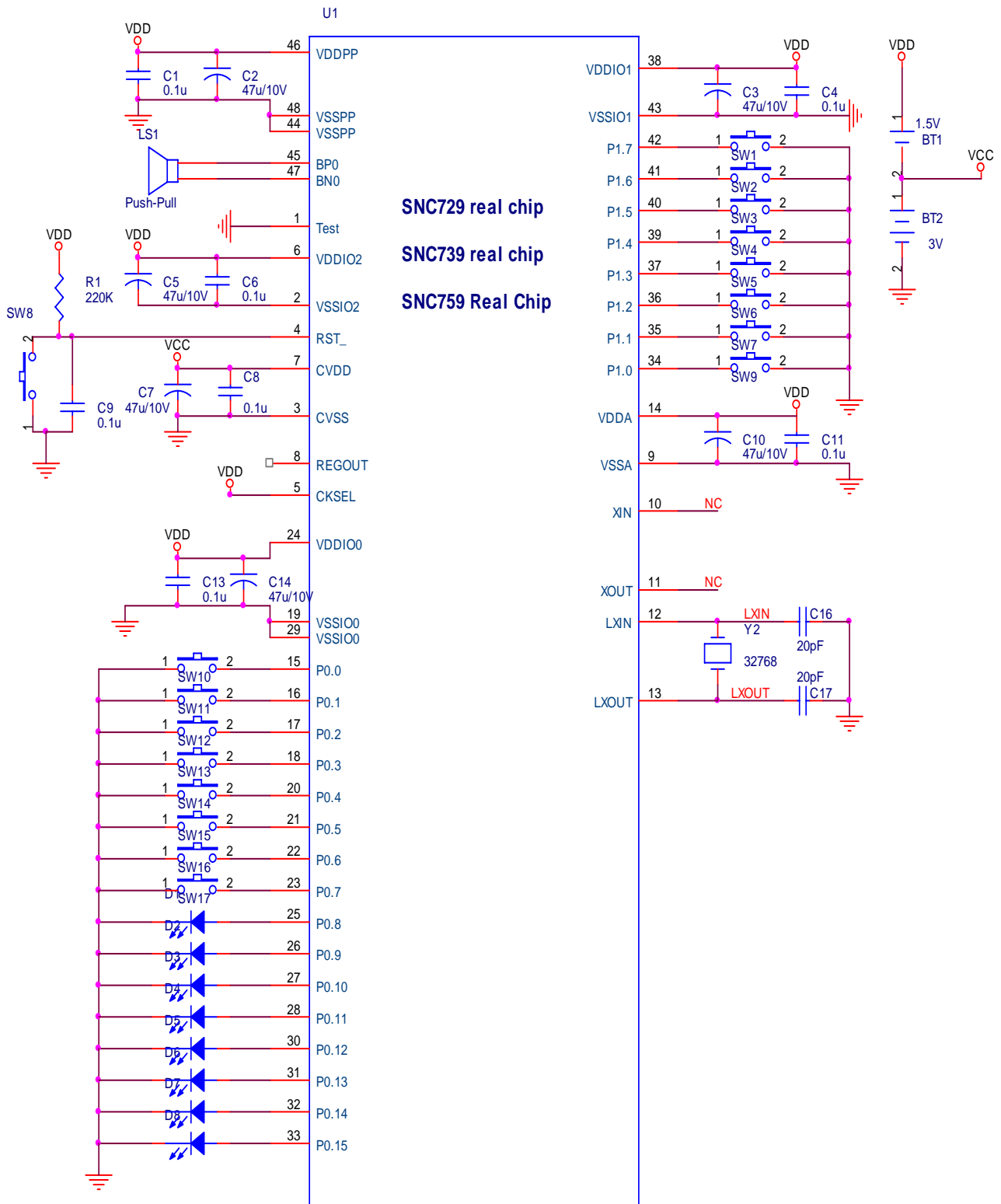

**Note:** The SNC759 total have 6 powers, each power use one 47uF and one 0.1uF capacitor. If user wants to save cost, you can use 0.1uF on each power and add 47uF on VDDPP and VDDA.



## 14. Bonding PAD

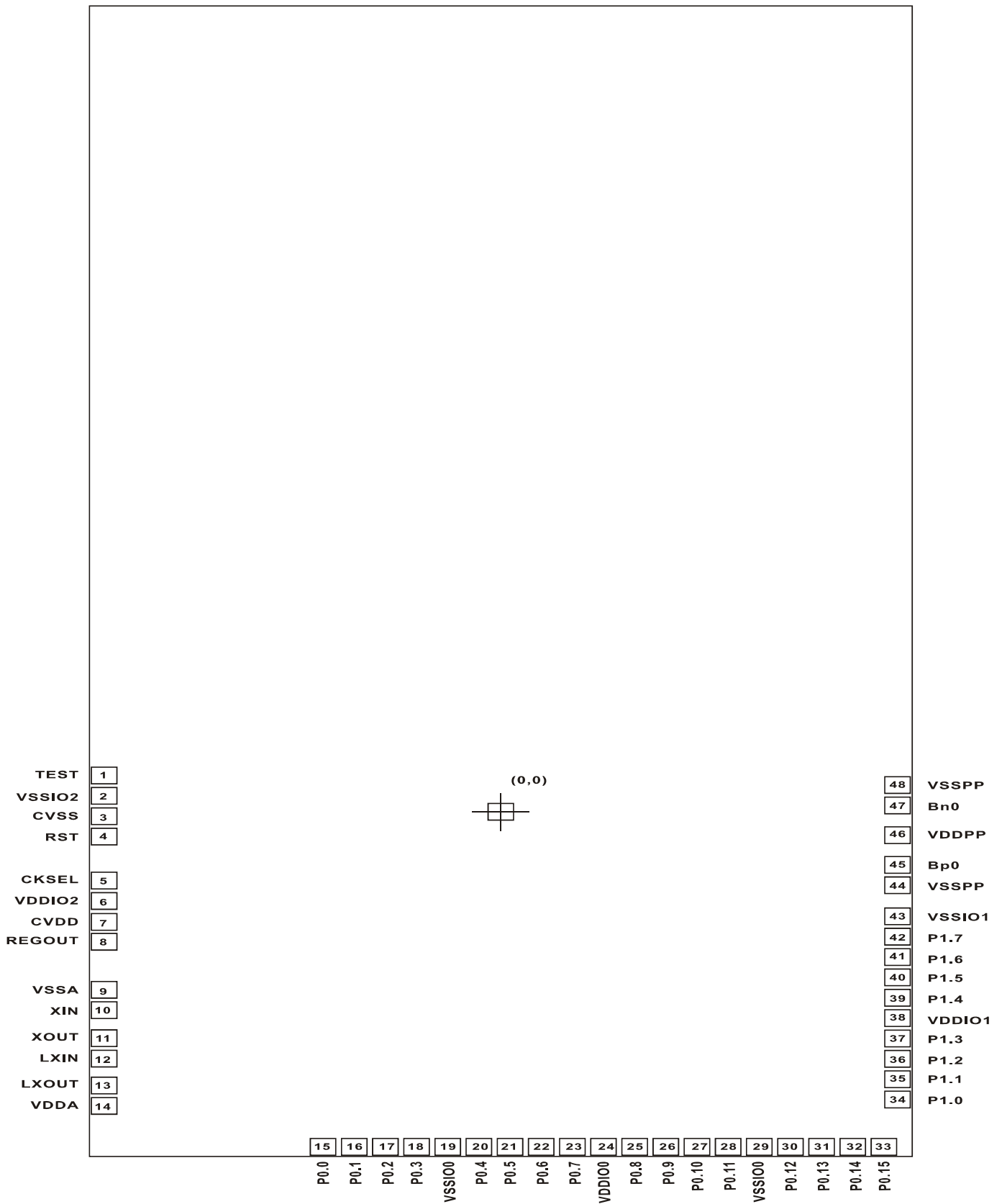



## DISCLAIMER

The information appearing in SONiX web pages (“this publication”) is believed to be accurate.

However, this publication could contain technical inaccuracies or typographical errors. The reader should not assume that this publication is error-free or that it will be suitable for any particular purpose. SONiX makes no warranty, express, statutory implied or by description in this publication or other documents which are referenced by or linked to this publication. In no event shall SONiX be liable for any special, incidental, indirect or consequential damages of any kind, or any damages whatsoever, including, without limitation, those resulting from loss of use, data or profits, whether or not advised of the possibility of damage, and on any theory of liability, arising out of or in connection with the use or performance of this publication or other documents which are referenced by or linked to this publication.

This publication was developed for products offered in Taiwan. SONiX may not offer the products discussed in this document in other countries. Information is subject to change without notice. Please contact SONiX or its local representative for information on offerings available. Integrated circuits sold by SONiX are covered by the warranty and patent indemnification provisions stipulated in the terms of sale only. The application circuits illustrated in this document are for reference purposes only. SONiX DISCLAIMS ALL WARRANTIES, INCLUDING THE WARRANTY OF MERCHANTABILITY OR FITNESS FOR ANY PURPOSE. SONiX reserves the right to halt production or alter the specifications and prices, and discontinue marketing the Products listed at any time without notice. Accordingly, the reader is cautioned to verify that the data sheets and other information in this publication are current before placing orders.

Products described herein are intended for use in normal commercial applications. Applications involving unusual environmental or reliability requirements, e.g. military equipment or medical life support equipment, are specifically not recommended without additional processing by SONiX for such application.